

REVISIONS					
P	LTR	DESCRIPTION	DATE	DWN	APVD
	H1	REVISED PER ECO-11-004917	11MAR11	RK	HMR
	J	REVISED PER ECO-18-019629	17DEC2018	RS	MZ
	K	REVISED PER ECO-19-000322	11JAN2019	RS	MZ
	L	REVISED PER ECO-19-004738	27MAR2019	RS	MZ

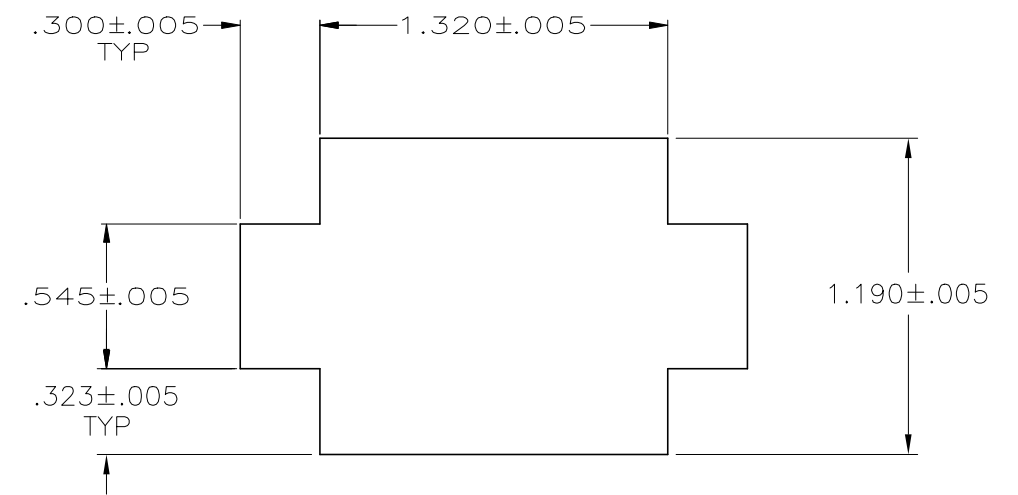

RECOMMENDED PANEL CUT-OUT
 PANEL THICKNESS .040-.093

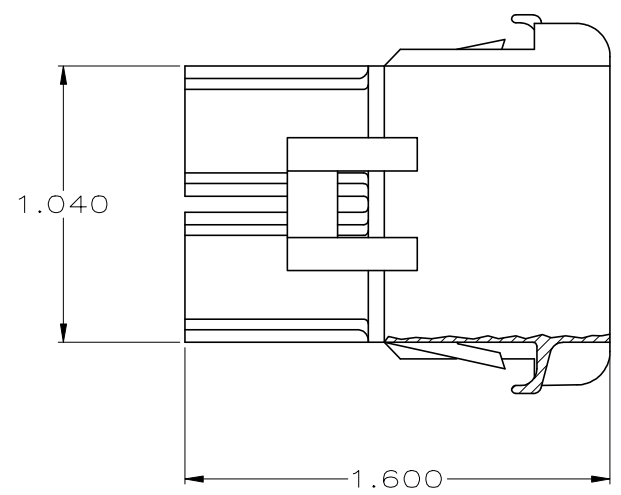
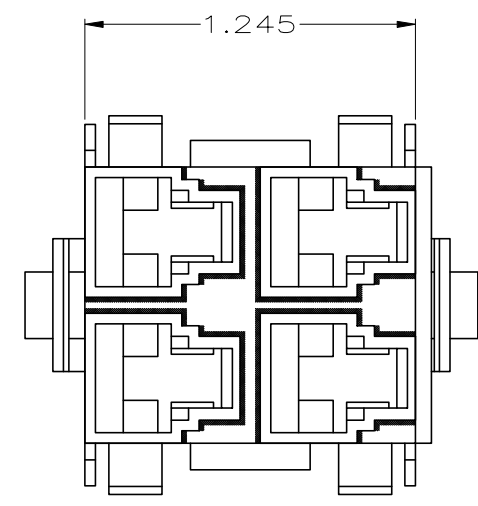
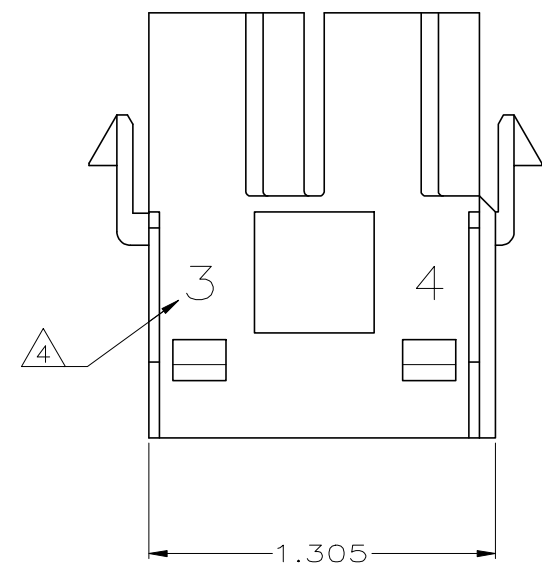

- ACCEPTS TERMINALS 350650 & 350651.
 - MATES WITH HOUSING 643267.
 - PANEL MUST BE PUNCHED SO THAT THE HOUSING ENTERS THE PANEL IN THE SAME DIRECTION AS THE PUNCH.
- ⚠ CHARACTERS 3 & 4 MARKED ON NEAR SURFACE AS SHOWN;
 CHARACTERS 1 & 2 MARKED OPPOSITE SIDE.
- ⚠ PA 6/66, UL 94V-0 RATED, BLACK

OBSOLETE	⚠	641685-2
	-	641685-1
CIRCUIT IDENTIFICATION		PART NUMBER

THIS DRAWING IS A CONTROLLED DOCUMENT.		DWN S.WELDON 04 OCT 99	TE Connectivity Ltd.	
DIMENSIONS: INCHES		CHK R.BUCHTER 05OCT99	NAME R.BUCHTER 05OCT99	
TOLERANCES UNLESS OTHERWISE SPECIFIED:		PRODUCT SPEC		
0 PLC ± - 1 PLC ± - 2 PLC ± - 3 PLC ± .020 4 PLC ± - ANGLES ± -		APPLICATION SPEC		
MATERIAL ⚠		FINISH -	WEIGHT -	RESTRICTED TO
		SIZE A2	CAGE CODE 00779	DRAWING NO C-641685
CUSTOMER DRAWING		SCALE 2:1	SHEET 1 of 1	REV L