

# ACFL-5212T

## Automotive R<sup>2</sup>Coupler™ Wide Operating Temperature 20kBd Digital Optocoupler Configurable as Low Power, Low Leakage Phototransistor



### Data Sheet



#### Description

The ACFL-5212T is an automotive grade dual channel, bi-directional, high CMR, 20kBd digital optocoupler, configurable as a low power, low leakage phototransistor, specifically for use in automotive applications. The stretched SO-12 package outline is designed to be compatible with standard surface mount processes and occupies the same land area as the single channel equivalent, ACPL-K49T, in stretched SO8 package.

This digital optocoupler uses an insulating layer between the light emitting diode and an integrated photo detector to provide electrical insulation between input and output. Separate connections for the photodiode bias and output transistor collector increase the speed up to a hundred times over that of a conventional photo-transistor coupler by reducing the base-collector capacitance.

Each channel is also galvanically isolated from each other with no cross-talk.

Avago R2Coupler provides reinforced insulation and reliability that delivers safe signal isolation critical in automotive and high temperature industrial applications.

#### Features

- Qualified to AEC Q100 Grade 1 Guidelines
- Wide Temperature Range: -40°C to +125°C
- Low LED Drive Current: 4mA (typ)
- Low Power, Low Leakage Phototransistor in a “4-pin Configuration” ( $I_{(CEO)} < 5\mu A$ )
- 30 kV/ $\mu s$  High Common-Mode Rejection at  $V_{CM} = 1500$  V (typ)
- Low Propagation Delay: 20 $\mu s$  (max)
- Compact, Auto-Insertable Stretched SO12 Packages
- Worldwide Safety Approval:
  - UL 1577 recognized, 5kV<sub>RMS</sub>/1 min.
  - CSA Component Acceptance Notice#5A
  - IEC/EN/DIN EN 60747-5-5

#### Applications

- Automotive Low Speed Digital Signal Isolation Interface
- Inverter Fault Feedback Signal Isolation
- Switching Power Supplies Feedback Circuit

#### Functional Diagram

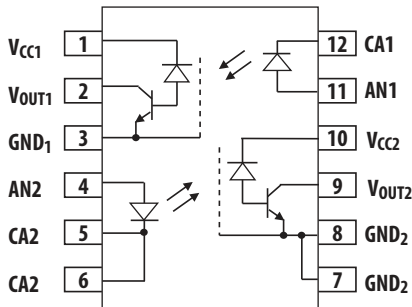

Note: The connection of a 1  $\mu F$  bypass capacitor between pins 1 and 3 and pins 8 and 10 is recommended.

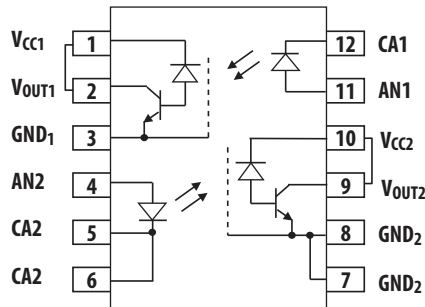

Note: Pins 1 and 2 and pins 9 and 10 are externally shorted for 4-pin configuration. Do not connect bypass capacitors in this configuration.

#### Truth Table

LED	VO
ON	LOW
OFF	HIGH

**CAUTION:** It is advised that normal static precautions be taken in handling and assembly of this component to prevent damage and/or degradation which may be induced by ESD. The components featured in this datasheet are not to be used in military or aerospace applications or environments.

## Pin Description

Pin No.	Pin Name	Description	Pin No.	Pin Name	Description
1	V <sub>CC1</sub>	Primary Side Power Supply	7	GND2	Secondary Side Ground
2	V <sub>OUT1</sub>	Output 1	8	GND2	Secondary Side Ground
3	GND1	Primary Side Ground	9	V <sub>OUT2</sub>	Output 2
4	AN2	Anode 2	10	V <sub>CC2</sub>	Secondary Side Power Supply
5	CA2	Cathode 2	11	AN1	Anode 1
6	CA2	Cathode 2	12	CA1	Cathode 1

## Ordering Information

Part number	Option (RoHS Compliant)	Package	Surface Mount	Tape & Reel	UL 5000 Vrms/ 1 Minute rating	IEC/EN/DIN EN 60747-5-5	Quantity
ACFL-5212T	-000E	Stretched SO-12	X		X		80 per tube
	-060E		X		X	X	80 per tube
	-500E		X	X	X		1000 per reel
	-560E		X	X	X	X	1000 per reel

To order, choose a part number from the part number column and combine with the desired option from the option column to form an order entry.

Example 1:

ACFL-5212T-560E to order product of SSO-12 Surface Mount package in Tape and Reel packaging with IEC/EN/DIN EN 60747-5-5 Safety Approval in RoHS compliant.

Option datasheets are available. Contact your Avago sales representative or authorized distributor for information.

# Package Outline Drawing

## 12-Lead Surface Mount

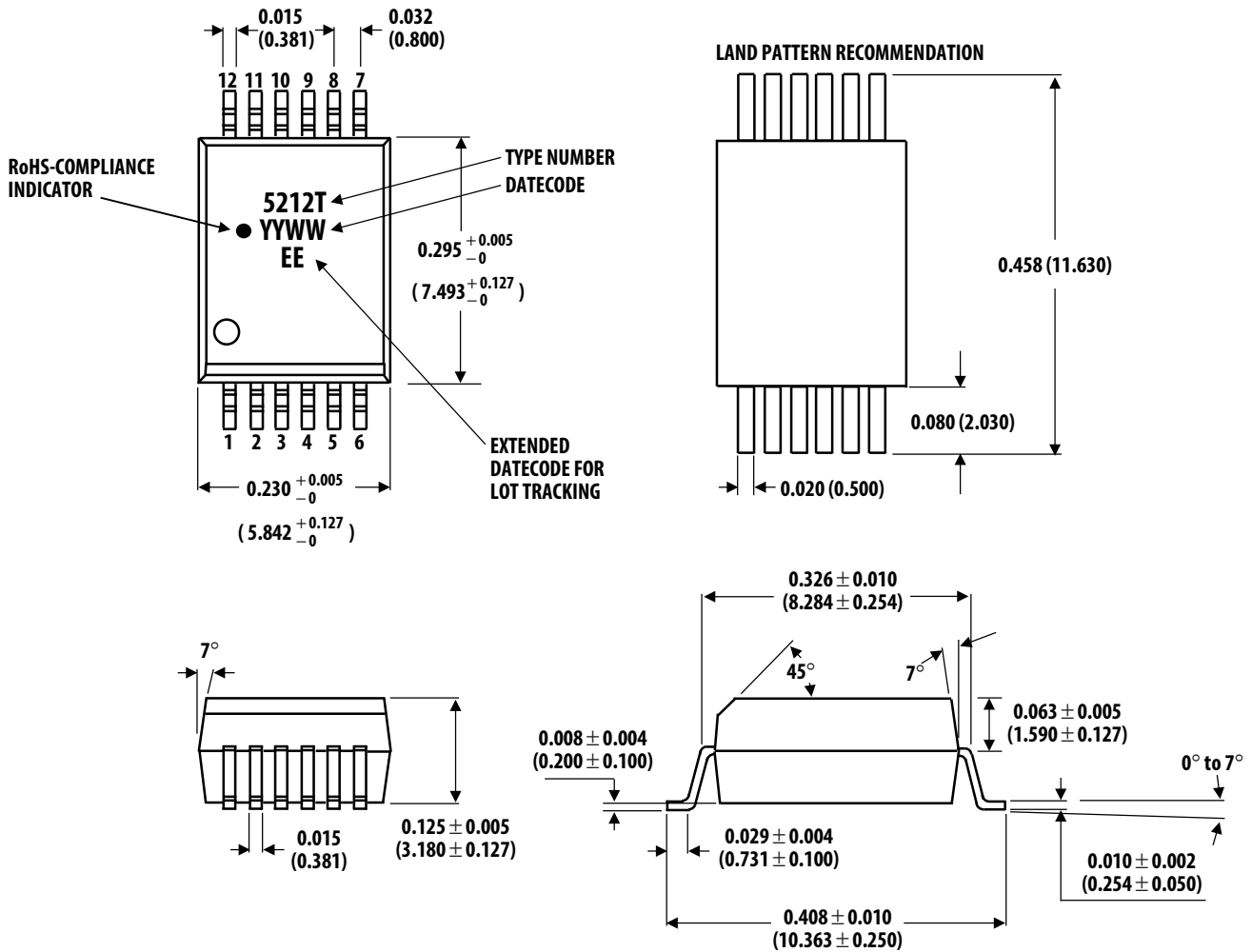

Dimensions in inches (millimeters)  
Lead coplanarity = 0.004 inches (0.1mm)

### Recommended Pb-Free IR Profile

Recommended reflow condition as per JEDEC Standard, J-STD-020 (latest revision).

Note: Non-halide flux should be used

## Regulatory Information

The ACFL-5212T is approved by the following organizations:

<b>UL</b>	Approved under UL 1577, component recognition program up to $V_{ISO} = 5kV_{RMS}$
<b>CSA</b>	Approved under CSA Component Acceptance Notice #5A
<b>IEC/EN/DIN EN 60747-5-5</b>	Approved under IEC/EN/DIN EN 60747-5-5

## Insulation and Safety Related Specifications

Parameter	Symbol	ACFL-5212T	Units	Conditions
Minimum External Air Gap (Clearance)	L(101)	8.3	mm	Measured from input terminals to output terminals, shortest distance through air.
Minimum External Tracking (Creepage)	L(102)	8.5	mm	Measured from input terminals to output terminals, shortest distance path along body.
Minimum Internal Plastic Gap (Internal Clearance)		0.08	mm	Through insulation distance conductor to conductor, usually the straight line distance thickness between the emitter and detector.
Tracking Resistance (Comparative Tracking Index)	CTI	175	V	DIN IEC 112/VDE 0303 Part 1
Isolation Group (DIN VDE0109)		IIIa		Material Group (DIN VDE 0109)

## IEC / EN / DIN EN 60747-5-5 Insulation Related Characteristic (Option 060E and 560E)

Description	Symbol	Characteristic	Units
Installation classification per DIN VDE 0110/1.89, Table 1 for rated mains voltage $\leq 600$ V rms for rated mains voltage $< 1000$ V rms		I-III I-III	
Climatic Classification		40/125/21	
Pollution Degree (DIN VDE 0110/1.89)		2	
Maximum Working Insulation Voltage	$V_{IORM}$	1140	$V_{PEAK}$
Input to Output Test Voltage, Method b $V_{IORM} \times 1.875 = V_{PR}$ , 100% Production Test with $t_m = 1$ sec, Partial Discharge $< 5$ pC	$V_{PR}$	2137	$V_{PEAK}$
Input to Output Test Voltage, Method a $V_{IORM} \times 1.6 = V_{PR}$ , Type and sample test, $t_m = 10$ sec, Partial Discharge $< 5$ pC	$V_{PR}$	1824	$V_{PEAK}$
Highest Allowable Overvoltage (Transient Overvoltage, $t_{ini} = 60$ sec)	$V_{IOTM}$	6000	$V_{PEAK}$
Safety Limiting Values (Maximum values allowed in the event of a failure)			
Case Temperature	$T_S$	175	$^{\circ}C$
Input Current	$I_{S,INPUT}$	230	mA
Output Power	$P_{S,OUTPUT}$	600	mW
Insulation Resistance at $T_S$ , $V_{IO} = 500$ V	$R_S$	$10^9$	$\Omega$

## Absolute Maximum Ratings

Parameter	Symbol	Min.	Max.	Units	Condition
Storage Temperature	$T_S$	-55	150	°C	
Operating Temperature	$T_A$	-40	125	°C	
Junction Temperature	$T_J$		150	°C	
Lead Soldering Cycle	Temperature		260	°C	
	Time		10	s	
Average Forward Input Current	$I_{F(avg)}$		20	mA	
Peak Forward Input Current (50% duty cycle, 1ms pulse width)	$I_{F(peak)}$		40	mA	
Peak Transient Input Current ( $\leq 1\mu s$ pulse width, 300ps)	$I_{F(trans)}$		100	mA	
Reversed Input Voltage	$V_R$		5	V	
Input Power Dissipation	$P_{IN}$		30	mW	
Output Power Dissipation	$P_O$		100	mW	
Average Output Current	$I_O$		8	mA	
Peak Output Current	$I_{O(pk)}$		16	mA	
Supply Voltage	$V_{CC1}/V_{CC2}$	-0.5	30	V	
Output Voltage	$V_{OUT1}/V_{OUT2}$	-0.5	20	V	
Solder Reflow Temperature Profile			See Reflow Temperature Profile		

## Recommended Operating Conditions

Parameter	Symbol	Min.	Max.	Units	Note
Supply Voltages	$V_{CC1}/V_{CC2}$		20.0	V	
Operating Temperature	$T_A$	-40	125	°C	

## Electrical Specifications (DC) for 5-Pin Configuration

Over recommended operating conditions, unless otherwise specified. All typical specifications are at  $T_A=25^\circ\text{C}$ ,  $V_{CC}=5\text{V}$ .

Parameter	Symbol	Min.	Typ.	Max.	Units	Test Conditions	Fig.	Note
Current Transfer Ratio	CTR	32	65	100	%	$T_A=25^\circ\text{C}$ , $V_{CC}=4.5\text{V}$ , $V_O=0.5\text{V}$ , $I_F=10\text{mA}$	1,2,3	1
		24	65			$V_{CC}=4.5\text{V}$ , $V_O=0.5\text{V}$ , $I_F=10\text{mA}$		
		65	110	150		$T_A=25^\circ\text{C}$ , $V_{CC}=4.5\text{V}$ , $V_O=0.5\text{V}$ , $I_F=4\text{mA}$	1,2,3	1
		50	110			$V_{CC}=4.5\text{V}$ , $V_O=0.5\text{V}$ , $I_F=4\text{mA}$		
Logic Low Output Voltage	$V_{OL}$		0.1	0.5	V	$T_A=25^\circ\text{C}$ , $I_F=10\text{mA}$ , $V_{CC}=4.5\text{V}$ , $I_O=2.4\text{mA}$ ,	3	
			0.1	0.5		$I_F=4\text{mA}$ , $V_{CC}=4.5\text{V}$ , $I_O=2.0\text{mA}$ ,		
Logic High Output Current	$I_{OH}$		0.003	0.5	$\mu\text{A}$	$T_A=25^\circ\text{C}$ , $V_O=V_{CC}=5.5\text{V}$ , $I_F=0\text{mA}$	7	
			0.01	5		$V_O=V_{CC}=20\text{V}$ , $I_F=0\text{mA}$		
Logic Low Supply Current	$I_{CCL}$		35	100	$\mu\text{A}$	$I_F=4\text{mA}$ , $V_O=\text{open}$ , $V_{CC}=20\text{V}$		
Logic High Supply Current	$I_{CCH}$		0.02	1	$\mu\text{A}$	$T_A=25^\circ\text{C}$ , $I_F=0\text{mA}$ , $V_O=\text{open}$ , $V_{CC}=20\text{V}$		
				2.5	$\mu\text{A}$	$I_F=0\text{mA}$ , $V_O=\text{open}$ , $V_{CC}=20\text{V}$		
Input Forward Voltage	$V_F$	1.2	1.5	1.8	V	$I_F=4\text{mA}$	6	
Input Reversed Breakdown Voltage	$BV_R$	5			V	$I_R=10\mu\text{A}$		
Temperature Coefficient of Forward Voltage	$\Delta V/\Delta T_A$		-1.5		$\text{mV}/^\circ\text{C}$	$I_F=10\text{mA}$		
Input Capacitance	$C_{IN}$		90		pF	$F=1\text{MHz}$ , $V_F=0$		

## Switching Specifications (AC) for 5-Pin Configuration

Over recommended operating conditions, unless otherwise specified. All typical specifications are at  $T_A=25^\circ\text{C}$ ,  $V_{CC}=5\text{V}$ .

Parameter	Sym.	Min.	Typ.	Max.	Units	Conditions	Fig.	Note
Propagation Delay Time to Logic Low at Output	$t_{PHL}$			20	$\mu\text{s}$	Pulse: $f=10\text{kHz}$ , Duty cycle = 50%, $I_F=4\text{mA}$ , $V_{CC}=5.0\text{V}$ , $R_L=8.2\text{k}\Omega$ , $C_L=15\text{pF}$ , $V_{THHL}=1.5\text{V}$	2	
Propagation Delay Time to Logic High at Output	$t_{PLH}$			20	$\mu\text{s}$	Pulse: $f=10\text{kHz}$ , Duty cycle = 50%, $I_F=4\text{mA}$ , $V_{CC}=5.0\text{V}$ , $R_L=8.2\text{k}\Omega$ , $C_L=15\text{pF}$ , $V_{THLH}=2.0\text{V}$	2	
Common Mode Transient Immunity at Logic High Output	$ CM_H $	15	30		$\text{kV}/\mu\text{s}$	$I_F=0\text{mA}$ , $V_{CM}=1500\text{Vp-p}$ , $T_A=25^\circ\text{C}$ , $R_L=1.9\text{k}\Omega$	3	
Common Mode Transient Immunity at Logic Low Output	$ CM_L $	15	30		$\text{kV}/\mu\text{s}$	$I_F=10\text{mA}$		
Common Mode Transient Immunity at Logic Low Output	$ CM_L $		15		$\text{kV}/\mu\text{s}$	$I_F=4\text{mA}$ , $V_{CM}=1500\text{Vp-p}$ , $T_A=25^\circ\text{C}$ , $R_L=8.2\text{k}\Omega$		

## Electrical Specifications (DC) for 4-Pin Configuration

Over recommended operating conditions, unless otherwise specified. All typical specifications are at  $T_A=25^\circ\text{C}$ ,  $V_{CC}=5\text{V}$ .

Parameter	Symbol	Min.	Typ.	Max.	Units	Test Conditions	Fig.	Note
Current Transfer Ratio	CTR		120		%	$T_A=25^\circ\text{C}$ , $V_{CC}=V_O=5\text{V}$ , $I_F=5\text{mA}$	4	5, 8
		70	130	250		$T_A=25^\circ\text{C}$ , $V_{CC}=V_O=5\text{V}$ , $I_F=4\text{mA}$		
Current Transfer Ratio	$CTR_{(\text{Sat})}$	24	60			$I_F=10\text{mA}$ , $V_{CC}=V_O=0.5\text{V}$	5	5, 8
		35	110			$I_F=4\text{mA}$ , $V_{CC}=V_O=0.5\text{V}$		
Logic Low Output Voltage	$V_{OL}$		0.1	0.5	V	$I_F=10\text{mA}$ , $V_{CC}=4.5\text{V}$ , $I_O=2.4\text{mA}$ ,	5	8
			0.1	0.4		$I_F=4\text{mA}$ , $V_{CC}=4.5\text{V}$ , $I_O=2.4\text{mA}$ ,		
Off-State Current	$I_{(\text{CEO})}$		$4 \times 10^{-4}$	5	$\mu\text{A}$	$V_O=V_{CC}=20\text{V}$ , $I_F=0\text{mA}$	8	8
Input Forward Voltage	$V_F$	1.2	1.5	1.8	V	$I_F=4\text{mA}$	6	
Input Reversed Breakdown Voltage	$BV_R$	5			V	$I_R=10\mu\text{A}$		
Temperature Coefficient of Forward Voltage	$\Delta V/\Delta T_A$		-1.5		mV/oC	$I_F=10\text{mA}$		
Input Capacitance	$C_{IN}$		90		pF	$F=1\text{MHz}$ , $V_F=0$		
Output Capacitance	$C_{CE}$		35		pF	$F=1\text{MHz}$ , $V_F=0$ , $V_O=V_{CC}=0\text{V}$		

## Switching Specifications (AC) for 4-Pin Configuration

Over recommended operating conditions, unless otherwise specified. All typical specifications are at  $T_A=25^\circ\text{C}$ ,  $V_{CC}=5\text{V}$ .

Parameter	Sym.	Min.	Typ.	Max.	Units	Conditions	Fig.	Note
Propagation Delay Time to Logic Low at Output	$t_{\text{PHL}}$		2	100	$\mu\text{s}$	Pulse: $f=1\text{kHz}$ , Duty cycle = 50%, $I_F=4\text{mA}$ , $V_{CC}=5.0\text{V}$ , $R_L=8.2\text{k}\Omega$ , $C_L=15\text{pF}$ , $V_{\text{THHL}}=1.5\text{V}$		8
Propagation Delay Time to Logic High at Output	$t_{\text{PLH}}$		19	100	$\mu\text{s}$	Pulse: $f=1\text{kHz}$ , Duty cycle = 50%, $I_F=4\text{mA}$ , $V_{CC}=5.0\text{V}$ , $R_L=8.2\text{k}\Omega$ , $C_L=15\text{pF}$ , $V_{\text{THLH}}=2.0\text{V}$		8
Common Mode Transient Immunity at Logic High Output	$ CM_H $	15	30		kV/ $\mu\text{s}$	$I_F=0\text{mA}$ , $V_{CM}=1500\text{Vp-p}$ , $T_A=25^\circ\text{C}$ , $R_L=8.2\text{k}\Omega$		8, 9
Common Mode Transient Immunity at Logic Low Output	$ CM_L $	15	30		kV/ $\mu\text{s}$	$I_F=4\text{mA}$ , $V_{CM}=1500\text{Vp-p}$ , $T_A=25^\circ\text{C}$ , $R_L=8.2\text{k}\Omega$		

## Package Characteristics

All Typical at  $T_A=25^\circ\text{C}$ .

Parameter	Symbol	Min.	Typ.	Max.	Units	Test Conditions	Fig.	Note
Input-Output Momentary Withstand Voltage*	$V_{ISO}$	5000			$V_{RMS}$	$RH \leq 50\%$ , $t=1\text{min}$ ; $T_A=25^\circ\text{C}$		6, 7
Input-Output Resistance	$R_{I-O}$		$10^{14}$		$\Omega$	$V_{I-O}=500\text{Vdc}$		6
Input-Output Capacitance	$C_{I-O}$		0.6		pF	$f=1\text{MHz}$ ; $V_{I-O}=0\text{Vdc}$		6

\* The Input-Output Momentary Withstand Voltage is a dielectric voltage rating that should not be interpreted as an input-output continuous voltage rating.

Notes:

- Current Transfer Ratio in percent is defined as the ratio of output collector current,  $I_O$ , to the forward LED input current,  $I_F$ , times 100.
- Use of  $1\mu\text{F}$  bypass capacitors connected between pins 1 and 3 and pins 8 and 10 for 5-pin configuration.
- Common transient immunity in a Logic High level is the maximum tolerable (positive)  $dV_{CM}/dt$  on the rising edge of the common mode pulse,  $V_{CM}$ , to assure that the output will remain in a Logic High state (i.e.,  $V_O > 2.0\text{V}$ ). Common mode transient immunity in a Logic Low level is the maximum tolerable (negative)  $dV_{CM}/dt$  on the falling edge of the common mode pulse signal,  $V_{CM}$  to assure that the output will remain in a Logic Low state (i.e.,  $V_O < 0.8\text{V}$ ).
- Device considered a two terminal device: pins 1 to 6 shorted together, and pins 7 to 12 shorted together.
- In accordance with UL 1577, each optocoupler is proof tested by applying an insulation test voltage  $> 6000V_{RMS}$  for 1 second.

## Typical Performance Plots

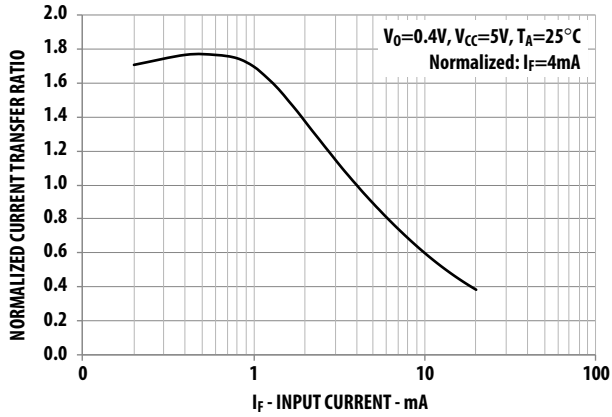

Figure 1. Current Transfer Ratio vs. Input Current

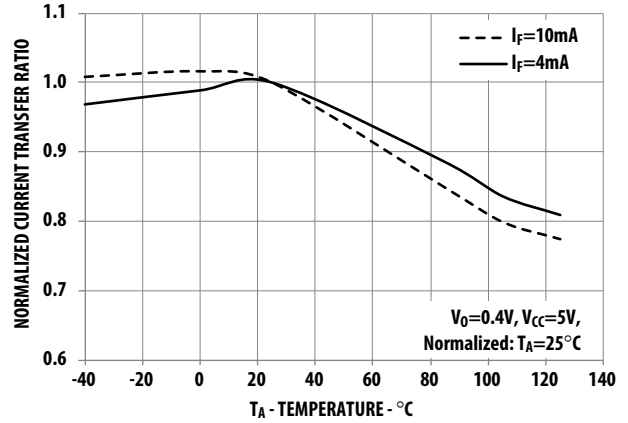

Figure 2. Normalized Current Transfer Ratio vs. Temperature

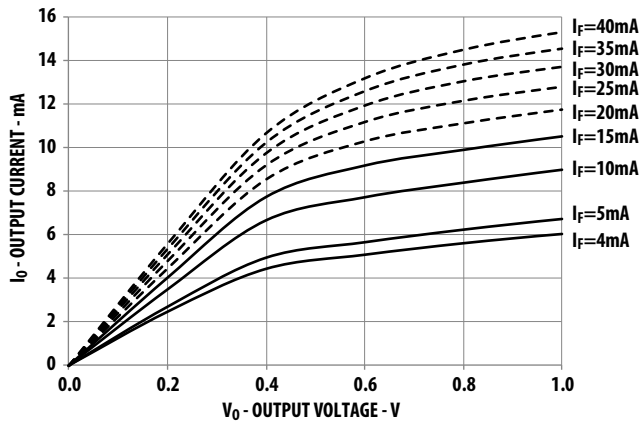

Figure 3. Typical Low Level Output Current vs Output Voltage

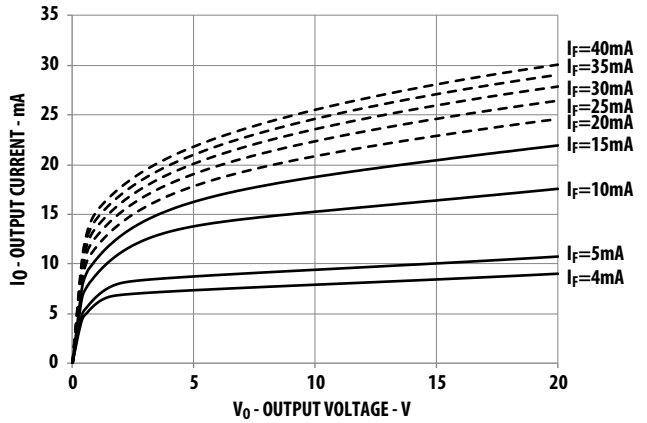

Figure 4. Output Current vs Output Voltage (4-Pin Configuration)

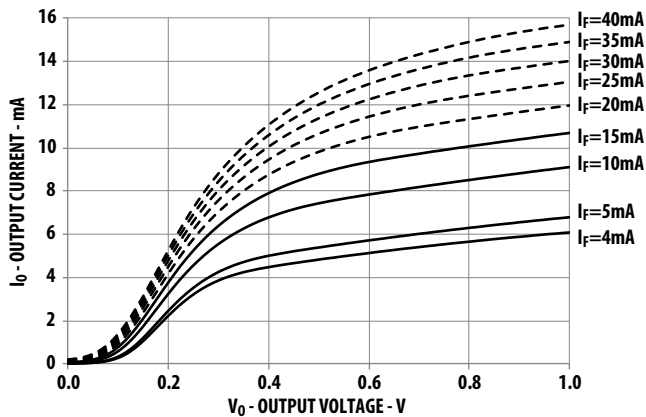

Figure 5. Typical Low Level Output Current vs Output Voltage (4-Pin Configuration)

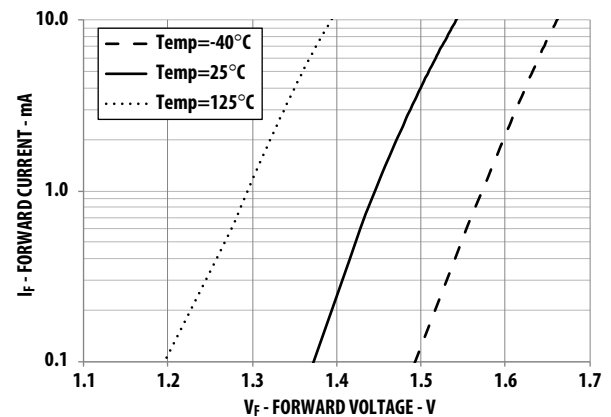

Figure 6. Typical Input Current vs Forward Voltage



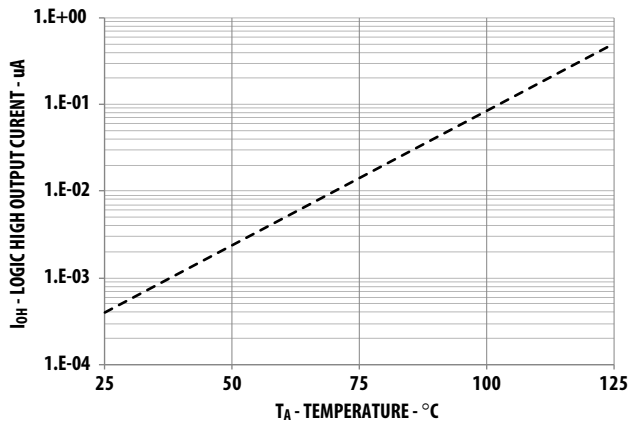

Figure 7. Typical High Level Output Current vs Temperature

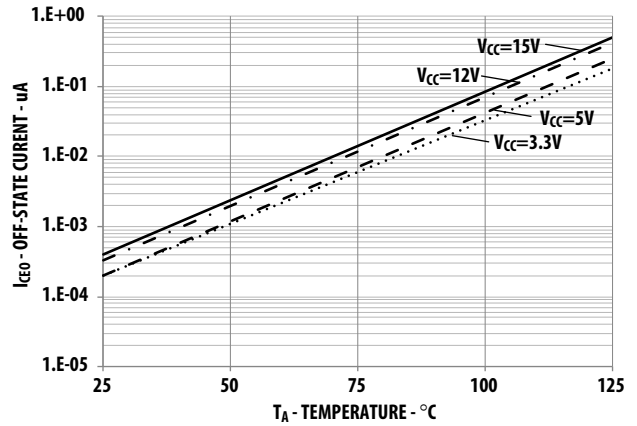

Figure 8. Typical Off-State Current vs Temperature (4-Pin Configuration)

### Test Circuits

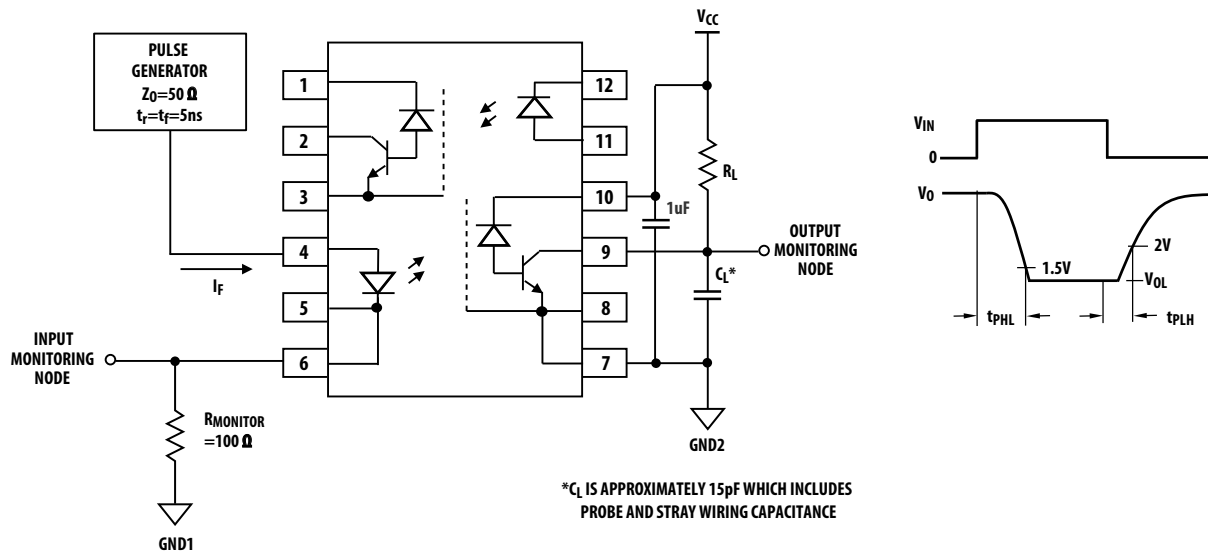

Figure 9. Switching Test Circuit (5-pin Configuration)

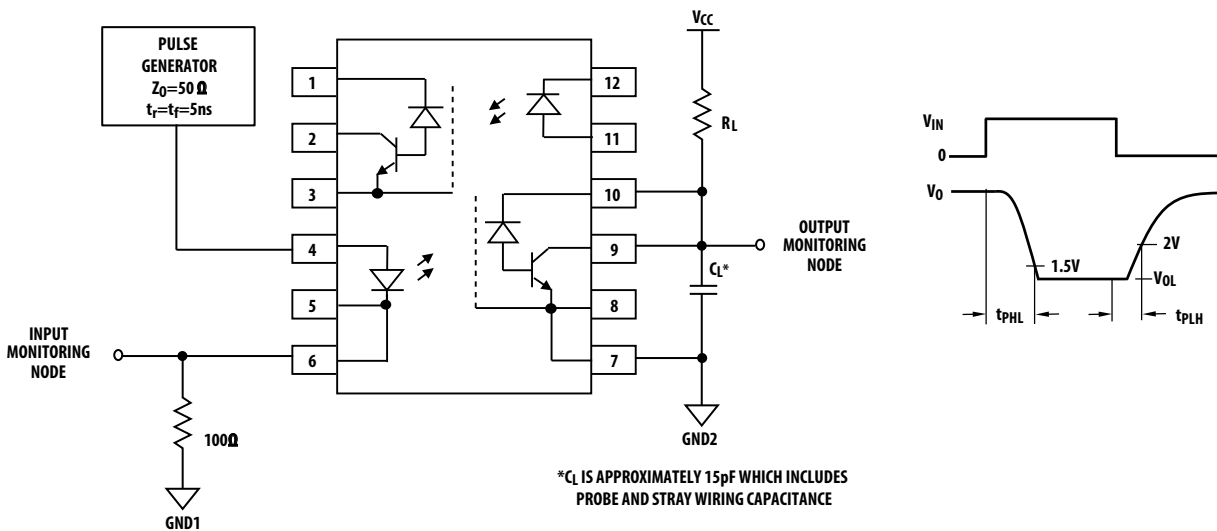

Figure 10. Switching Test Circuit (4-pin Configuration)

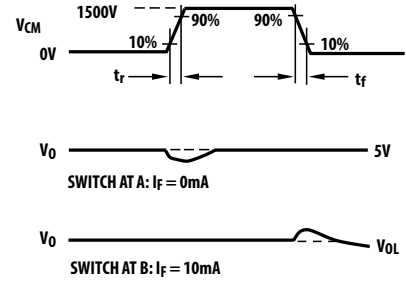
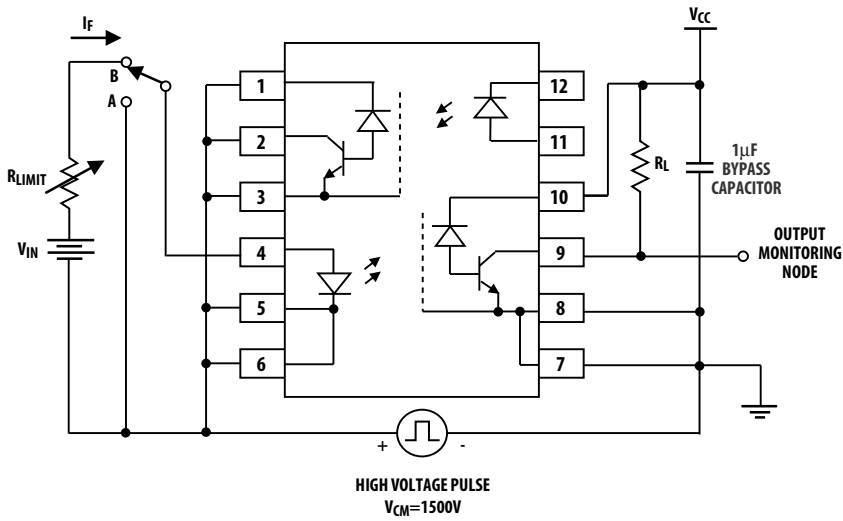

Figure 11. Test Circuit for Transient Immunity and Typical Waveforms (5-Pin Configuration)

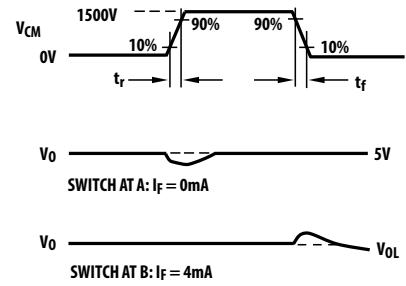
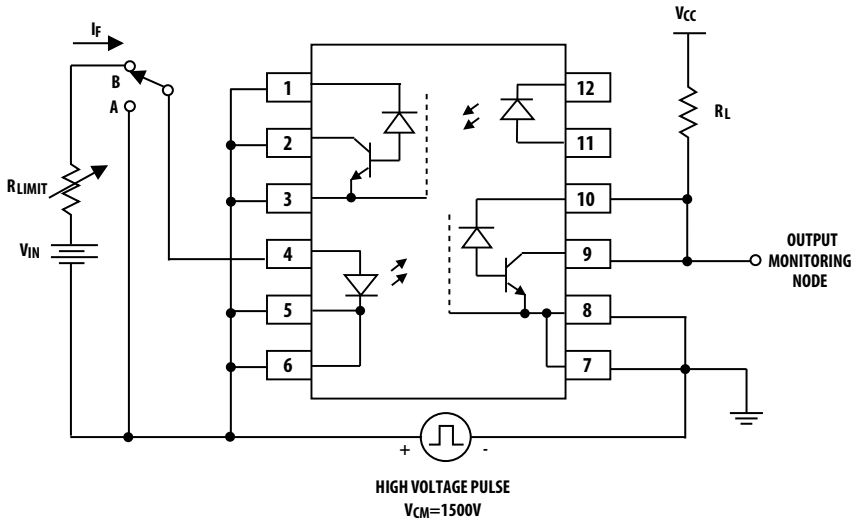

Figure 12. Test Circuit for Transient Immunity and Typical Waveforms (4-Pin Configuration)

## Thermal Resistance Measurement

The diagram of ACFL-5212T for measurement is shown in Figure 13. This is a multi-chip package with four heat sources, the effect of heating of one die due to the adjacent dice are considered by applying the theory of linear superposition. Here, one die is heated first and the temperatures of all the dice are recorded after thermal equilibrium is reached. Then, the 2nd die is heated and all the dice temperatures are recorded and so on until the 4th die is heated. With the known ambient temperature, the die junction temperature and power dissipation, the thermal resistance can be calculated. The thermal resistance calculation can be cast in matrix form. This yields a 4 by 4 matrix for our case of two heat sources.

$$\begin{vmatrix} R_{11} & R_{12} & R_{13} & R_{14} \\ R_{21} & R_{22} & R_{23} & R_{24} \\ R_{31} & R_{32} & R_{33} & R_{34} \\ R_{41} & R_{42} & R_{43} & R_{44} \end{vmatrix} \cdot \begin{vmatrix} P_1 \\ P_2 \\ P_3 \\ P_4 \end{vmatrix} = \begin{vmatrix} \Delta T_1 \\ \Delta T_2 \\ \Delta T_3 \\ \Delta T_4 \end{vmatrix}$$

R<sub>11</sub>: Thermal Resistance of Die1 due to heating of Die1 (°C/W)

R<sub>12</sub>: Thermal Resistance of Die1 due to heating of Die2 (°C/W)

R<sub>13</sub>: Thermal Resistance of Die1 due to heating of Die3 (°C/W)

R<sub>14</sub>: Thermal Resistance of Die1 due to heating of Die4 (°C/W)

R<sub>21</sub>: Thermal Resistance of Die2 due to heating of Die1 (°C/W)

R<sub>22</sub>: Thermal Resistance of Die2 due to heating of Die2 (°C/W)

R<sub>23</sub>: Thermal Resistance of Die2 due to heating of Die3 (°C/W)

R<sub>24</sub>: Thermal Resistance of Die2 due to heating of Die4 (°C/W)

R<sub>31</sub>: Thermal Resistance of Die3 due to heating of Die1 (°C/W)

R<sub>32</sub>: Thermal Resistance of Die3 due to heating of Die2 (°C/W)

R<sub>33</sub>: Thermal Resistance of Die3 due to heating of Die3 (°C/W)

R<sub>34</sub>: Thermal Resistance of Die3 due to heating of Die4 (°C/W)

R<sub>41</sub>: Thermal Resistance of Die4 due to heating of Die1 (°C/W)

R<sub>42</sub>: Thermal Resistance of Die4 due to heating of Die2 (°C/W)

R<sub>43</sub>: Thermal Resistance of Die4 due to heating of Die3 (°C/W)

R<sub>44</sub>: Thermal Resistance of Die4 due to heating of Die4 (°C/W)

P<sub>1</sub>: Power dissipation of Die1 (W)

P<sub>2</sub>: Power dissipation of Die2 (W)

P<sub>3</sub>: Power dissipation of Die3 (W)

P<sub>4</sub>: Power dissipation of Die4 (W)

T<sub>1</sub>: Junction temperature of Die1 due to heat from all dice (°C)

T<sub>2</sub>: Junction temperature of Die2 due to heat from all dice (°C)

T<sub>3</sub>: Junction temperature of Die3 due to heat from all dice (°C)

T<sub>4</sub>: Junction temperature of Die4 due to heat from all dice (°C)

T<sub>a</sub>: Ambient temperature.

ΔT<sub>1</sub>: Temperature difference between Die1 junction and ambient (°C)

ΔT<sub>2</sub>: Temperature difference between Die2 junction and ambient (°C)

ΔT<sub>3</sub>: Temperature difference between Die3 junction and ambient (°C)

ΔT<sub>4</sub>: Temperature difference between Die4 junction and ambient (°C)

$$T_1 = (R_{11} \times P_1 + R_{12} \times P_2 + R_{13} \times P_3 + R_{14} \times P_4) + T_a \quad -- (1)$$

$$T_2 = (R_{21} \times P_1 + R_{22} \times P_2 + R_{23} \times P_3 + R_{24} \times P_4) + T_a \quad -- (2)$$

$$T_3 = (R_{31} \times P_1 + R_{32} \times P_2 + R_{33} \times P_3 + R_{34} \times P_4) + T_a \quad -- (3)$$

$$T_4 = (R_{41} \times P_1 + R_{42} \times P_2 + R_{43} \times P_3 + R_{44} \times P_4) + T_a \quad -- (4)$$

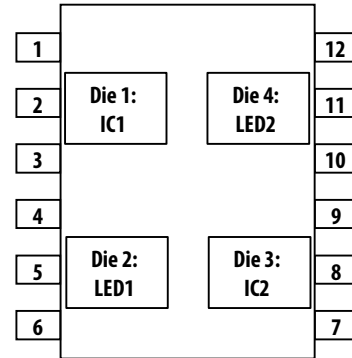

Figure 13. Diagram of ACFL-5212T for measurement

### Measurement data on a low K (conductivity) board:

R<sub>11</sub> = 181 °C/W

R<sub>21</sub> = 103 °C/W

R<sub>31</sub> = 82 °C/W

R<sub>41</sub> = 110 °C/W

R<sub>12</sub> = 91 °C/W

R<sub>22</sub> = 232 °C/W

R<sub>32</sub> = 97 °C/W

R<sub>42</sub> = 86 °C/W

R<sub>13</sub> = 85 °C/W

R<sub>23</sub> = 109 °C/W

R<sub>33</sub> = 180 °C/W

R<sub>43</sub> = 101 °C/W

R<sub>14</sub> = 112 °C/W

R<sub>24</sub> = 91 °C/W

R<sub>34</sub> = 91 °C/W

R<sub>44</sub> = 277 °C/W

### Measurement data on a high K (conductivity) board:

R<sub>11</sub> = 117 °C/W

R<sub>21</sub> = 37 °C/W

R<sub>31</sub> = 35 °C/W

R<sub>41</sub> = 47 °C/W

R<sub>12</sub> = 42 °C/W

R<sub>22</sub> = 161 °C/W

R<sub>32</sub> = 53 °C/W

R<sub>42</sub> = 30 °C/W

R<sub>13</sub> = 32 °C/W

R<sub>23</sub> = 39 °C/W

R<sub>33</sub> = 114 °C/W

R<sub>43</sub> = 29 °C/W

R<sub>14</sub> = 60 °C/W

R<sub>24</sub> = 33 °C/W

R<sub>34</sub> = 34 °C/W

R<sub>44</sub> = 189 °C/W

For product information and a complete list of distributors, please go to our web site: [www.avagotech.com](http://www.avagotech.com)

Avago, Avago Technologies, and the A logo are trademarks of Avago Technologies in the United States and other countries.  
Data subject to change. Copyright © 2005-2015 Avago Technologies. All rights reserved.  
AV02-4893EN - August 11, 2015

