

NOTICE OF PROPRIETARY RIGHTS THIS DOCUMENT CONTAINS CONFIDENTIAL TECHNICAL DATA, INCLUDING TRADE SECRETS, PROPRIETARY TO TIMES MICROWAVE SYSTEMS. DISCLOSURE OF THIS DATA IS EXPRESSLY CONDITIONED UPON YOUR ASSENT THAT ITS USE IS LIMITED TO USE WITHIN YOUR COMPANY ONLY. ANY OTHER USE IS STRICTLY PROHIBITED WITHOUT THE PRIOR WRITTEN CONSENT OF TIMES MICROWAVE SYSTEMS.

SYM	REVISION DESCRIPTION	DFTM	DATE	APPD	DATE
A	RELEASED FOR PRODUCTION	D. J. H.	3/15/11	J. D. B.	8/16/11
B	CHANGED PER CDC #40843	N. N. N.	10/8/14	J. D. B.	10/29/14
C	CHANGED PER CDC #43760	D. J. H.	1/27/16	J. D. B.	2/2/16

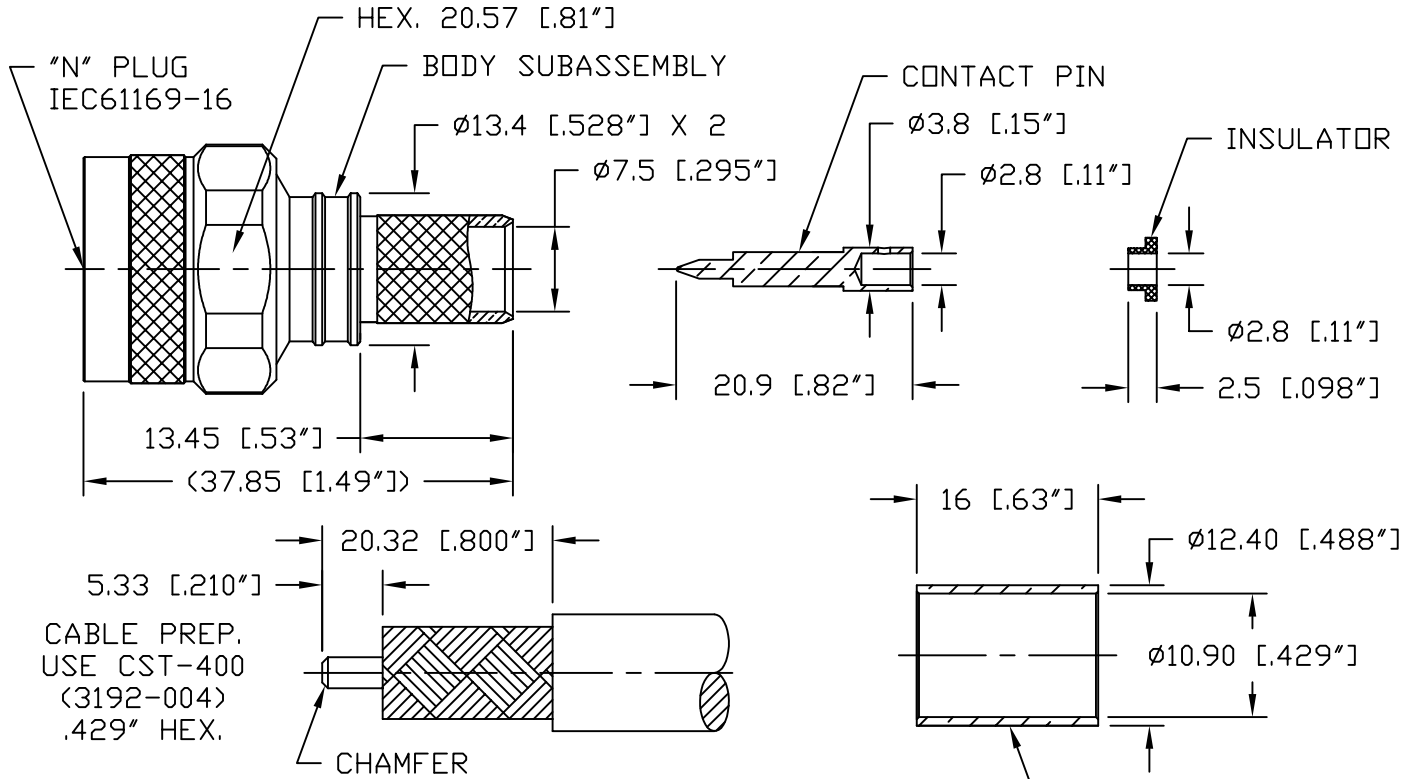

1. Electric Performance

Impedance (Ω):	50
Frequency Range (GHz):	0-6.0
VSWR:	<1.30:1 up to 6GHz
Insertion Loss (dB):	$0.05 \times \sqrt{f}$ (GHz)
Insulation Resistance ($M\Omega$):	≥ 5000
Dielectric Withstanding Voltage (V):	1500
Conductor Resistance (m Ω):	
Outer Conductor:	<0.4
Inner Conductor:	<0.8

2. Mechanical Performance

Coupling Nut Torque (N.m):	1.7
Coupling Nut Retention Force (N):	500
Cable-Connect Torque (N.m):	1.0
Cable-Connect Retention Force (N):	400
Durability (cycles)	≥ 500

3. Material and Plating

Component	Material	Plating
Body Shell	Brass	Albaloy 80 μ " min.
Contact Pin	Brass	Gold 50 μ " min.
Insulator	PTFE	
Ferrule	Copper	Albaloy 100 μ " min.
Gasket	Silicone Rubber	
Shrink Tube	3:1 Adhesive Lined Polyolefin (3/4" ID x 2" Long)	

4. Environment

Temperature Range	-55°C~+125°C
Thermal Shock	MIL-STD 202G, Meth.107, Cond.B
Vibration	MIL-STD 202G, Meth.204, Cond.B
Shock	MIL-STD 202G, Meth.213, Cond.I
Climatic Class	IEC 60068 55/155/56

5. RoHS Compliance

All raw materials and product manufactured by Supplier should be RoHS compliant. (RoHS2.0 2011/65/EU)

MATERIAL:	UNLESS OTHERWISE SPECIFIED ALL DIMENSIONS ARE IN mm MACHINED SURFACES FINISH N/A RMS MAX. REMOVE ALL BURRS N/A MAX. BREAK MACHINE CORNERS N/A MAX. FILLET R. TOLERANCES ON DECIMALS . XX \pm N/A . XXX \pm N/A ANGLES \pm 1° FRACTIONS \pm N/A	DFTM. D. J. H.	TIMES MICROWAVE SYSTEMS
		DATE 3/15/11	
USED ON:		CHKD. J. D. B.	TC-400-NMH-X "N" MALE FOR LMR-400 CABLE SOLDER/CRIMP/NO BRAID TRIM
		DATE 8/16/11	
SCALE: N/A	DWG. SIZE A	APPD. J. D. B.	SHEET 1 of 1 SD3190-2626 REV C
		DATE 8/16/11	
DO NOT SCALE DRAWING		CODE IDENT 68999	