

PRODUCT NUMBER ("LF" DENOTES LEAD-FREE)	CONTACT PLATING NOTE	CONTACT DEPTH (SEE SECTION A-A)				ROHS COMPATIBILITY
		POSN 1	POSN 2	POSN 3	POSN 4	
10098550-4444P00LF	2a	LONG	LONG	LONG	LONG	SEE NOTE 8
10098550-5555P00LF	2a	SHORT	SHORT	SHORT	SHORT	SEE NOTE 8
10098550-5545P00LF	2a	SHORT	SHORT	LONG	SHORT	SEE NOTE 8

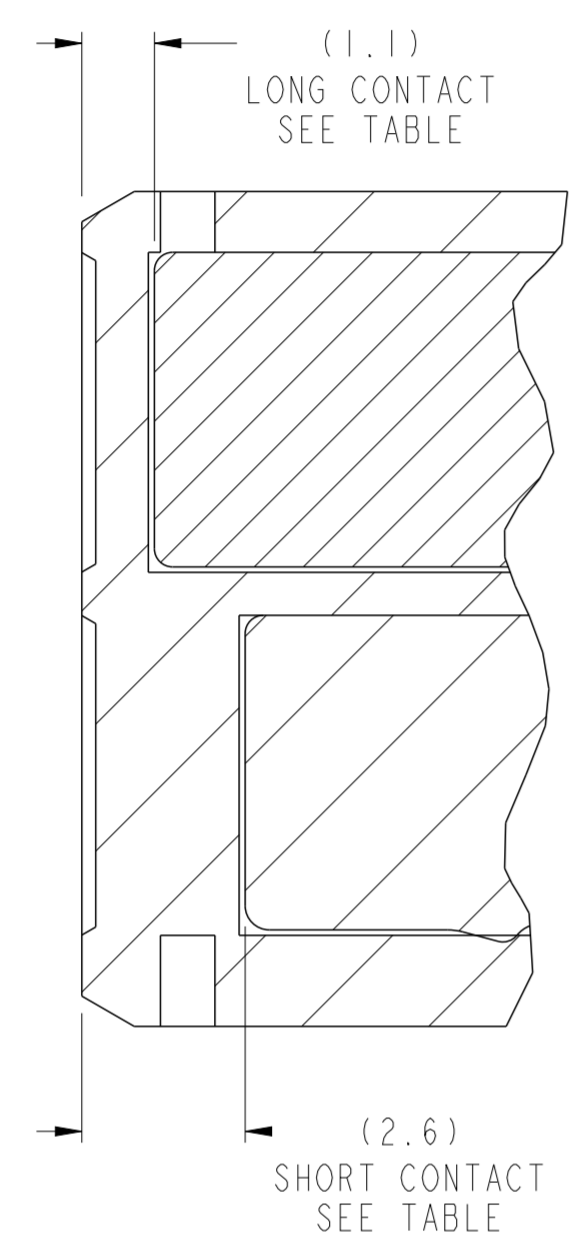

SECTION A-A
SCALE 8:1

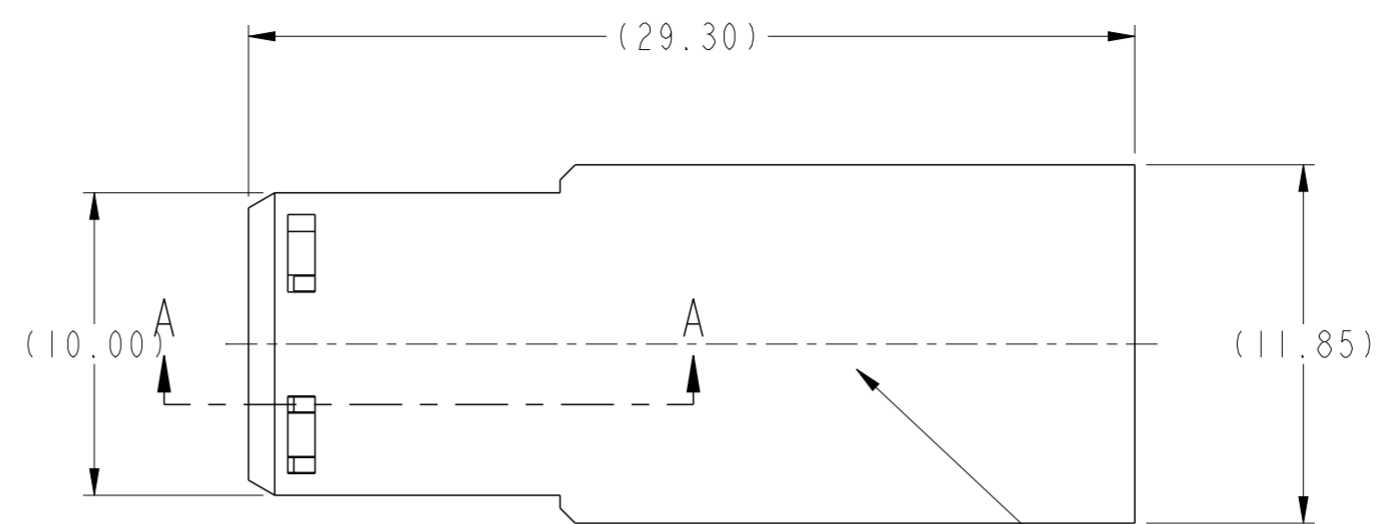
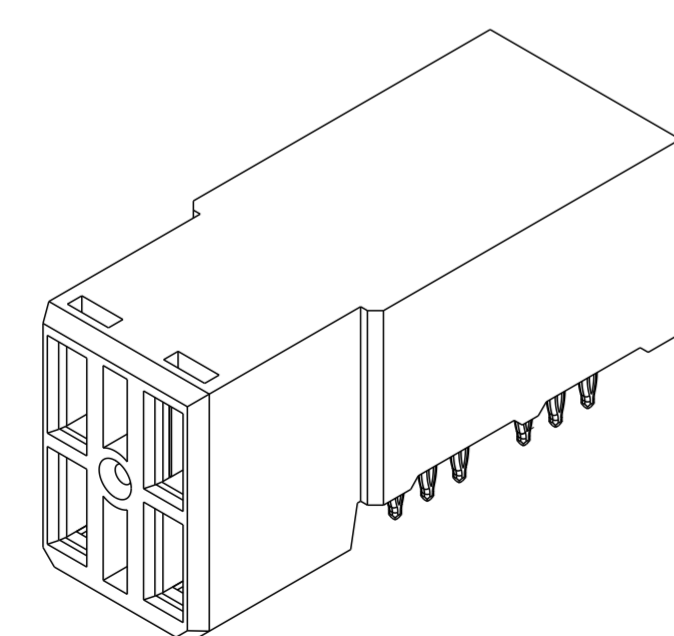
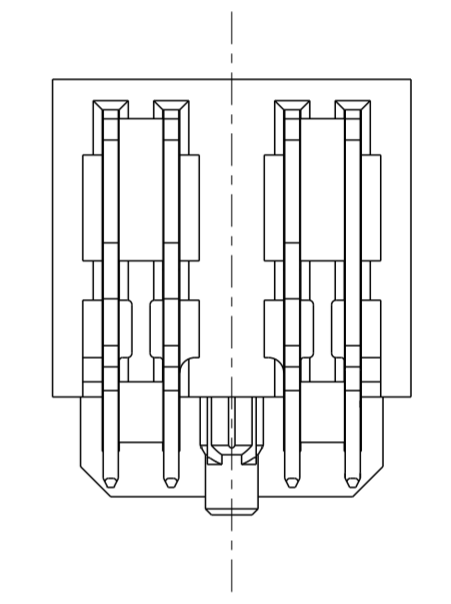
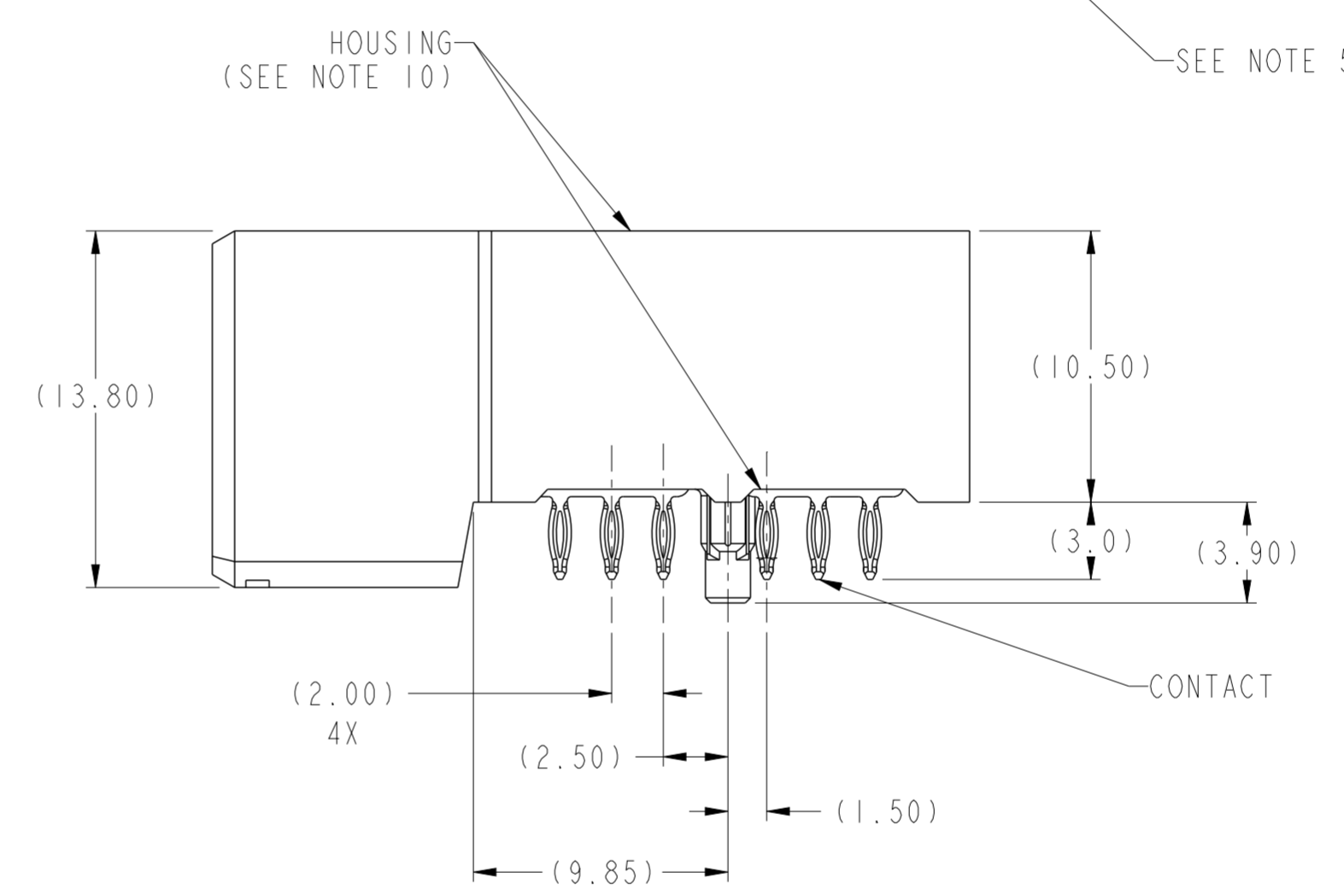
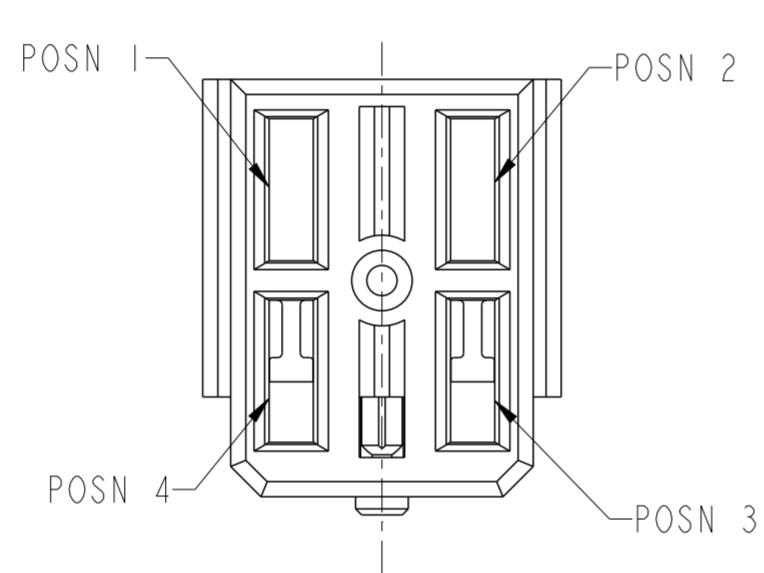

SCALE 3:1

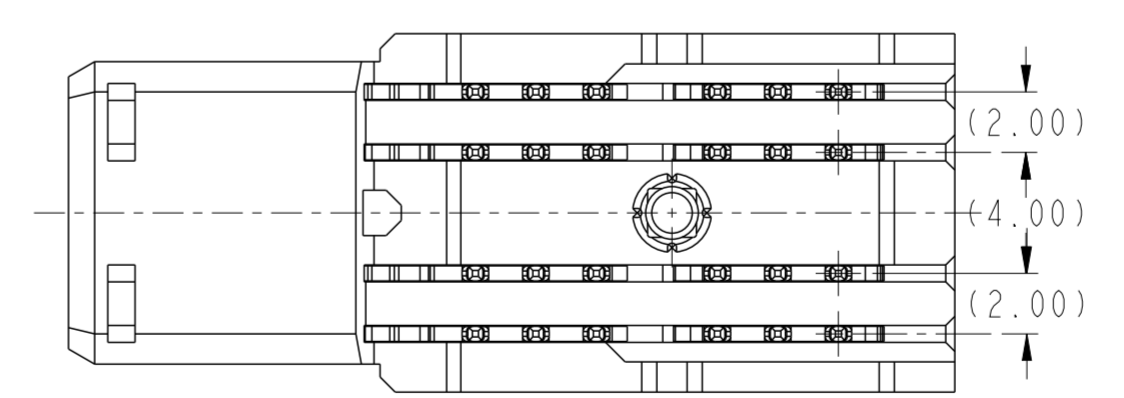

spec ref	GS-12-220	dr	Chen-Hong Tan	2009/03/23	projection	MM	size	A2	scale	4:1	
tolerance std	ASME Y14.5	eng	Suzie Nah	2014/07/14	chr	-	ecn no	ELX-S-18277-1	rel level	Released	
surface	✓	appr	Chen-Hong Tan	2014/08/20	product family	2mm High Power	cat. no.	-	Product - Customer Drw	sheet 1 of 2	
ASME Y14.5	linear	0.X	±0.3	0.XX	±0.10	0.XXX	±0.050	angular	0°	±°	
		www.fci.com		title		Co-planar R/A Receptacle Assy		10098550		rev	C
				PDS: Rev :C		STATUS:Released		Printed: Aug 20, 2014			

Copyright FCI.
FCI

TOP LAYER DESCRIPTION	TABLE 1 PLATED THROUGH-HOLE REQUIREMENTS							
	DRILLED HOLE DIAMETER	COPPER THICKNESS	TIN-LEAD THICKNESS	NICKEL THICKNESS	GOLD THICKNESS	TIN THICKNESS	SILVER THICKNESS	FINISHED HOLE DIAMETER
TIN-LEAD	0.81-0.86 (0.85 DRILL)	0.025 - 0.050	0.005 - 0.015	--	--	--	--	0.65 - 0.80
IMMERSION TIN	0.81-0.86 (0.85 DRILL)	0.025 - 0.050	--	--	--	0.9 - 1.5um	--	0.70 - 0.80
IMMERSION SILVER	0.81-0.86 (0.85 DRILL)	0.025 - 0.050	--	--	--	--	0.15 - 0.65um	0.70 - 0.80
COPPER (SEE NOTE 11)	0.81-0.86 (0.85 DRILL)	0.025 - 0.050	--	--	--	--	--	0.70 - 0.80
GOLD	0.81-0.86 (0.85 DRILL)	0.025 - 0.050	--	0.003 - 0.007	FLASH UP TO 0.0002	--	--	0.69 - 0.80

NOTES:

1. CONNECTOR MATERIALS:
HOUSING: HIGH TEMPERATURE THERMOPLASTIC, BLACK
UL 94V-0 COMPLIANT
CONTACT: HIGH PERFORMANCE COPPER ALLOY
2. a) CONTACT PLATING (LEAD FREE):
PRESS-FIT TAIL: 0.5um MIN MATTE TIN OVER 0.5um MIN NICKEL.
SEPARABLE INTERFACE: 0.76um MIN GOLD OVER 2.54um MIN NICKEL.
LUBRICATED WITH ZIPCHEM ZC026
b) CONTACT PLATING (LEADED): NOT APPLICABLE
PRESS-FIT TAIL: NOT APPLICABLE
SEPARABLE INTERFACE: NOT APPLICABLE
3. PRODUCT SPECIFICATION: GS-12-220
4. APPLICATION SPECIFICATION: GS-20-023
5. PRODUCT MARKING (PRODUCT NUMBER & DATE CODE) ON HOUSING IN AREA SHOWN.
6. MINIMUM NOMINAL PCB THICKNESS: 1.6mm
7. REFER TO CUSTOMER DRAWING 10035911 FOR INFORMATION REGARDING PCB LAYOUT OF POWER AND GUIDE MODULES RELATIVE TO SIGNAL MODULES.
8. PRODUCT MEETS EUROPEAN UNION DIRECTIVES AND OTHER COUNTRY REGULATIONS AS DESCRIBED IN FCI SPECIFICATION GS-22-008.
9. PACKAGING MEETS FCI SPECIFICATION GS-14-920.
10. HOUSING COMPONENT WILL WITHSTAND EXPOSURE TO 260°C PEAK TEMPERATURE FOR 60 SECONDS IN A CONVECTION, INFRA-RED, OR VAPOR PHASE REFLOW OVEN.
11. COPPER PLATING THICKNESS IN CENTER OF VIA-HOLE CAN BE NO MORE THAN 0.003 LESS THAN OTHER AREAS.
12. A \triangle SYMBOL WILL BE NEXT TO ANY DIMENSIONS, VIEW OR NOTE WHICH HAS BEEN MODIFIED WITH THE CURRENT DRAWING REVISION

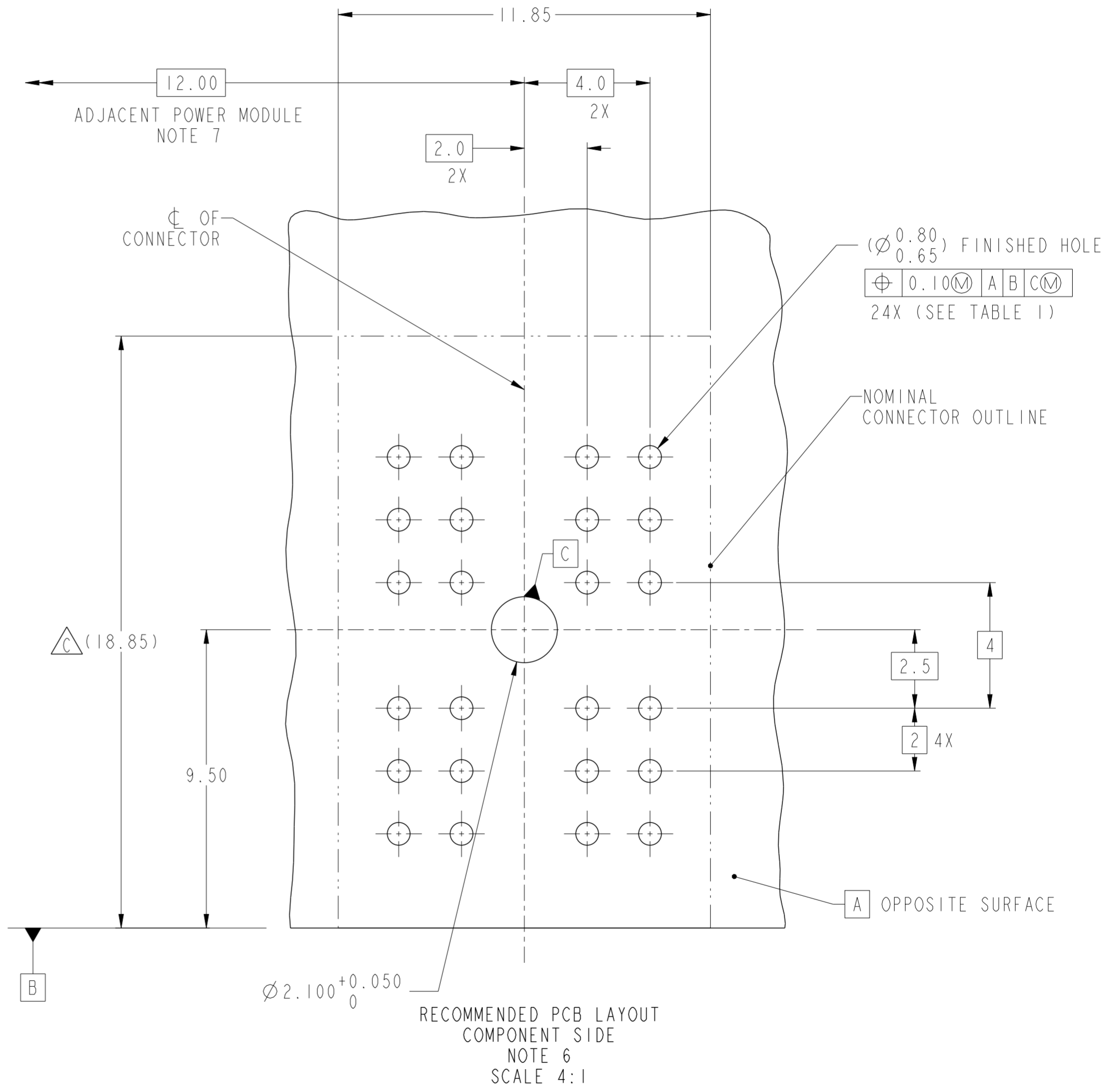

spec ref	GS-12-220	dr	Chen-Hong Tan	2009/03/23	projection	MM	size	A2	scale	8:1				
tolerance std	ASME Y14.5	eng	Suzie Nah	2014/07/14			ecn no	ELX-S-18277-1						
		chr						rel level	Released					
surface	✓	appr	Chen-Hong Tan	2014/08/20	product family		title	Co-planar R/A Receptacle Assy		rev	C			
ASME Y14.5	linear	0.X	±0.3	0.XX	±0.10	0.XXX	±0.050	angular	0°	±°	www.fci.com	cat. no.	Product - Customer Drw	sheet 2 of 2

Copyright FCI.