

Typical unit

FEATURES

- 60W Thirty-Second Brick DC-DC converter
- 23.36 x 19.05 x 12.7 mm Size
- 36-75V Input Voltage range
- 5V Output Voltage (Adjustable 4.5V-5.5V)
- 92.4% Peak efficiency
- 2250Vdc Input-Output Isolation
- Operating Temperature range -40 to +85 °C

PRODUCT OVERVIEW

The MYBTA00512ABT is an isolated, regulated, Thirty-Second Brick DC-DC converter that has an input range of 36-75Vdc with a typical efficiency of 92%, and full 2250 Volt DC isolation.

The MYBTA00512ABT is ideal for Small Cell, PoE PD, and Another small equipments.

The module has many self-protection features. These include input undervoltage lockout. The output current limit is using the hiccup autorestart technique. Additional features include output overvoltage protection.

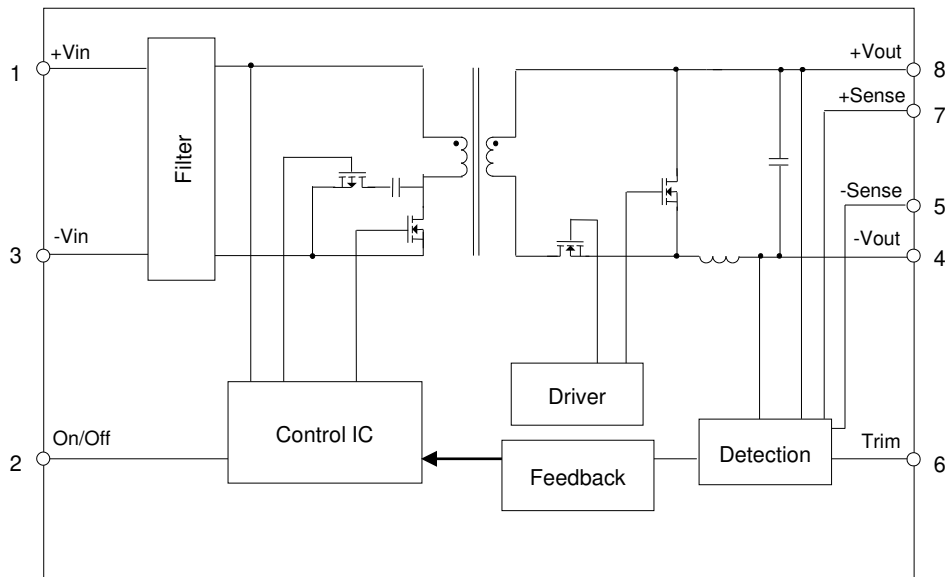
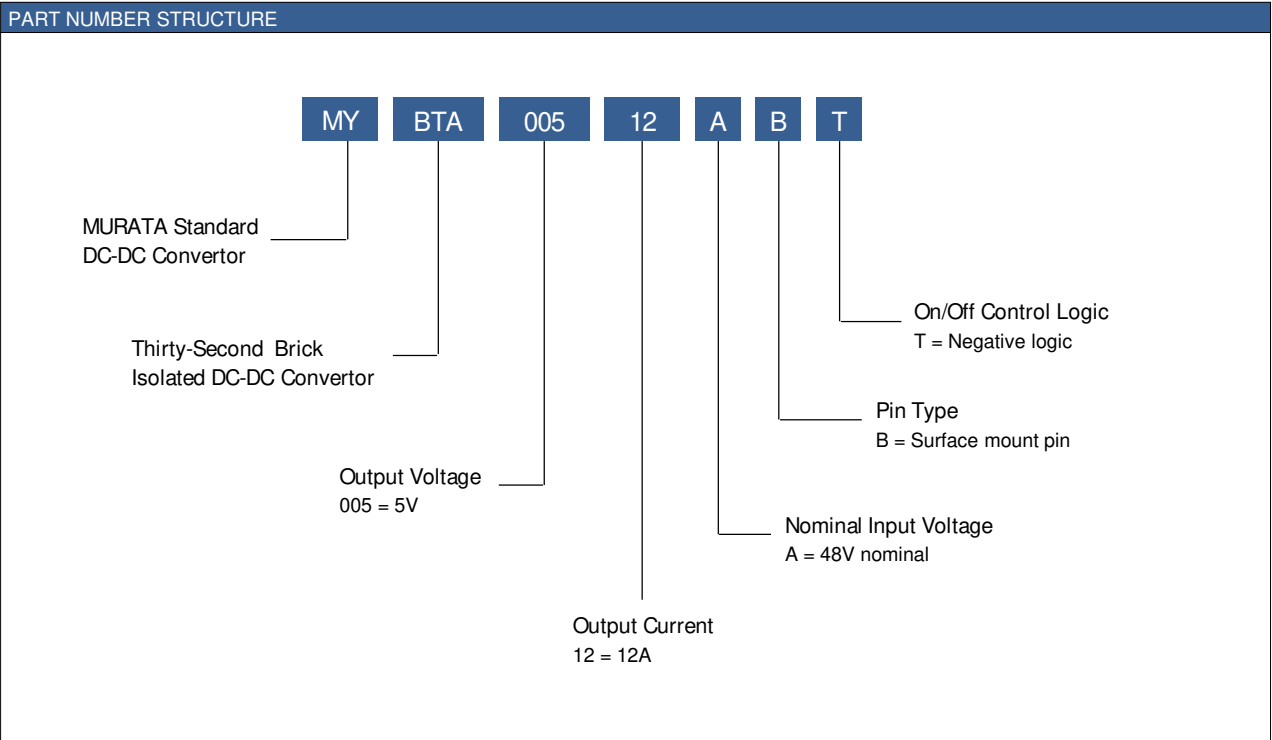

Figure 1. Simplified Block Diagram
Typical topology is shown.



PERFORMANCE SPECIFICATIONS SUMMARY AND ORDERING GUIDE													
Model Number	Output						Input				Efficiency (%)		Package (mm)
	Vout (Vdc)	Iout (A,Max.)	Power (W)	R/N Max. (mVp-p)	Regulation Typ.		Vin Nom. (Vdc)	Range (Vdc)	lin, no load Typ.(mA)	lin, full load Typ.(A)	Min.	Typ.	
					Line (%)	Load (%)							
MYBTA00512ABT	5	12	60	100	±0.1	±0.1	48	36-75	65	1.37	89	92	23.36 x 19.05 x 12.7

1. Please refer to the Part Number Structure for additional ordering information and options.
2. All specifications are at nominal line voltage, full load, +25°C unless otherwise stated.



Product Marking

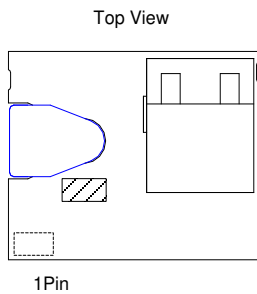

- Codes
- Ⓜ MFG ID
 - ▨ Product Code
 - ⋯ Internal Manufacturing Code

Part Number	Product Code
MYBTA00512ABT	CD

FUNCTIONAL SPECIFICATIONS, MYBTA00512ABT

ABSOLUTE MAXIMUM RATINGS	Conditions	Minimum	Typical / Nominal	Maximum	Units
Input Voltage, Continuous		0		75	Vdc
Input Voltage, Transient	100ms max. duration, Slew rate 52V/10µs			100	Vdc
Isolation Voltage	Input to output, Leak current 1mA max for 1minute at +25°C/60%RH.			2250	Vdc
Output Power		0		60	W
Output Current	Current-limited, no damage, short-circuit protected	0		12	A
Storage Temperature Range	Vin = Zero (no power)	-40		90	°C
Absolute maximums are stress ratings. Exposure of devices to greater than any of these conditions may adversely affect long-term reliability. Proper operation under conditions other than those listed in the Performance/Functional Specifications Table is not implied or recommended.					
INPUT					
Operating Voltage Range		36	48	75	Vdc
Start-up threshold	Rising input voltage	32		36	Vdc
Hysteresis Voltage	Input voltage difference between start-up and undervoltage shutdown		2		Vdc
Internal Filter Type			LC type		
External Input fuse (Recommended)*1			5		A
Input current					
Full Load Conditions	Vin = nom., Iout = max		1.37		A
Low Line Input current	Vin = min., Iout = max.		1.85		A
No Load Current	Vin = nom., Iout = min.		65		mA
Shut-Down Mode Input Current	On/Off = Off		5		mA
GENERAL and SAFETY					
Efficiency	Vin = 48V, full load	89	92		
Isolation					
Isolation Voltage	Input to output, Leak current 1mA max for 1minute at +25°C/60%RH.	2250			Vdc
Insulation Safety Rating			Functional		
Isolation Capacitance			1500		pF
Safety	Certified to UL60950(UL/C-UL)		Done		
Calculated MTBF	Telcordia SR-332, issue 1, class 3, ground fixed, Ta = +25°C		1830		Hours x 10 ³
DYNAMIC CHARACTERISTIC					
Fixed Switching Frequency			600		kHz
Vin Startup delay time	Power On to Vout regulated		20		ms
Enable startup delay time	Remote On to Vout regulated		20		ms
Vout Rise Time	From 10%-90% of Vout		30		ms
Dynamic Load Response	50-100-50% load step to 1% of Vout		200		µSec
Dynamic Load Peak Deviation	same as above		±80		mVdc

FUNCTIONAL SPECIFICATIONS, MYBTA00512ABT(CONT.)

OUTPUT	Conditions	Minimum	Typical / Nominal	Maximum	Units
Total Output Power		0		60	W
Voltage					
Nominal Output Voltage	No trim, all conditions	4.85	5	5.15	Vdc
Overvoltage Protection		6			Vdc
Current					
Output Current Range		0		12	A
Current Limit Inception		12.4			A
Short circuit protection method	Hiccup current limiting		Non-latching		
Regulation					
Line Regulation	Vin=min. to max., Vout=nom., full load		±0.1		% of Vout
Load Regulation	Iout = min. to max.		±0.1		% of Vout
Ripple and Noise	150 MHz BW, Cout=1µF MLCC paralleled with 10µF and 47µF			100	mV pk-pk
Temperature Coefficient	At all outputs		±0.002		% of Vout/°C
External Output Capacitance	Low ESR	47		400	µF
MECHANICAL					
Outline Dimensions	L x W x H		23.36 x 19.05 x 12.7		mm
Weight			10.1		Grams
Pin Diameter			1.6		mm
Pin Material			Copper alloy		
ENVIRONMENTAL					
Operating Ambient Temperature Range		-40		85	°C
Storage Temperature	Vin = Zero (no power)	-40		90	°C
Thermal Protection/Shutdown	Measured at hotspot		N/A		°C
Electromagnetic Interference Conducted, VCCI	External filter is required		B		Class

Specification Notes

Unless otherwise noted, all specifications are typical at nominal input voltage, nominal output voltage and full load. General conditions are +25°C ambient temperature, near sea level altitude, natural convection airflow. All models are tested and specified with external parallel 0.1µF and 10µF and 47µF output capacitors (See Technical Notes).

*1 External Input fuse is described in UL report. For greatest safety, we recommend a fast blow fuse installed in the ungrounded input supply line.

PERFORMANCE DATA MYBTA00512ABT

Efficiency vs. Line Voltage and Load Current
($T_a=+25^\circ\text{C}$)

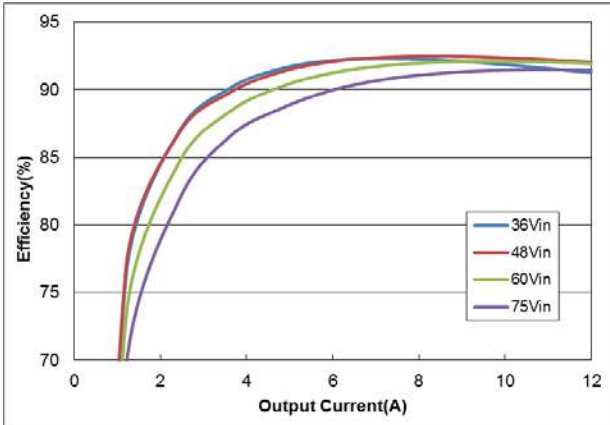

Load Regulation ($T_a=+25^\circ\text{C}$)

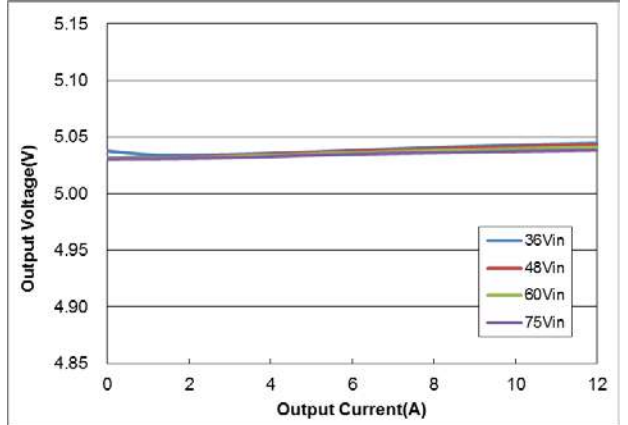

Thermal Derating (forced air cooling)
($V_{in}=48\text{V}$, See Technical Notes)

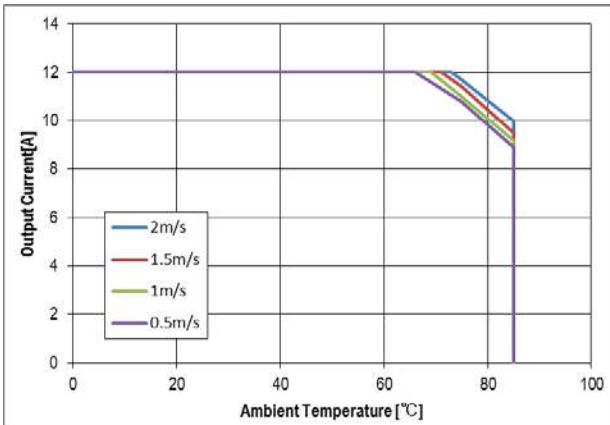

Thermal Derating (conduction cooling)
($V_{in}=48\text{V}$, See Technical Notes)

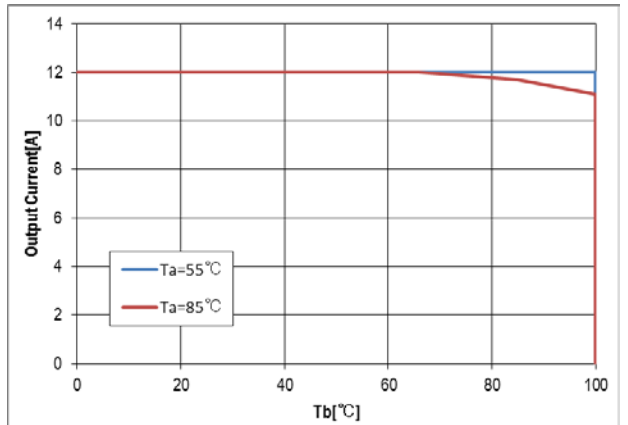

Output Ripple and Noise
($V_{in}=48\text{V}$, $V_{out}=5\text{V}$, $I_{out}=12\text{A}$, $T_a=+25^\circ\text{C}$)

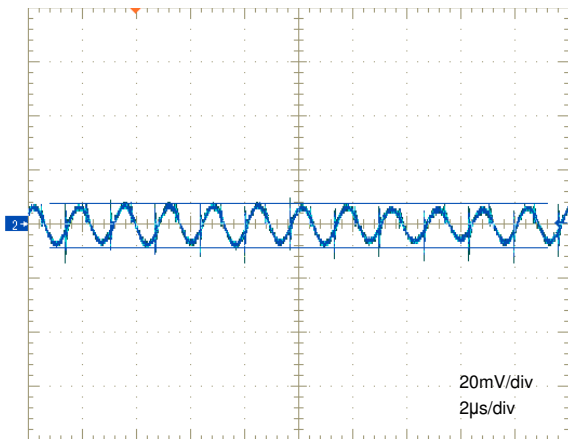

PERFORMANCE DATA MYBTA00512ABT(CONT.)

Transient Response ($V_{in}=48V$, $I_{out}=6A$ to $12A$, $T_a=+25^{\circ}C$)
Ch3= V_{out} , 100mV/div, Ch4= I_{out} , 5A/div



Transient Response ($V_{in}=48V$, $I_{out}=12A$ to $6A$, $T_a=+25^{\circ}C$)
Ch3= V_{out} , 100mV/div, Ch4= I_{out} , 5A/div

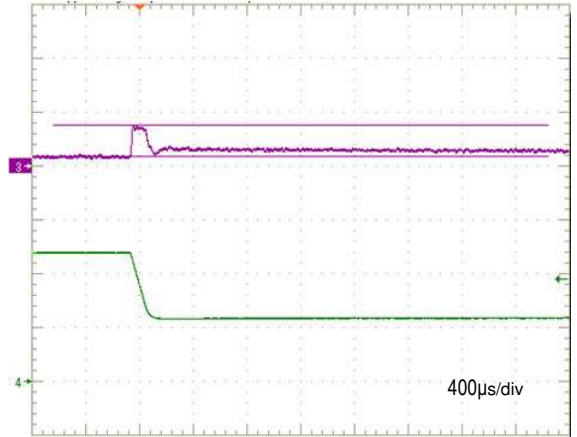

Start-up ($V_{in}=48V$, $V_{out}=5V$, $I_{out}=12A$, $T_a=+25^{\circ}C$)
Ch1= V_{in} , 50V/div, Ch2= V_{out} , 2V/div.

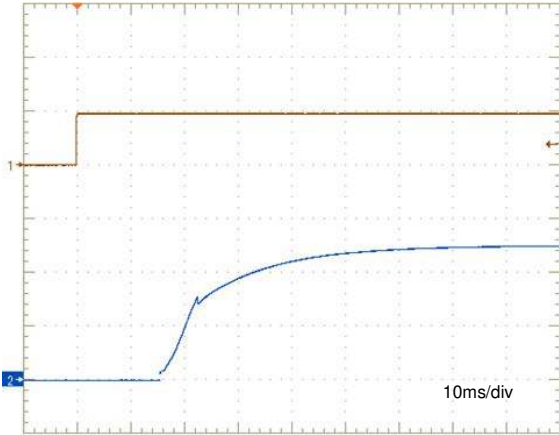

On/Off Enable Start-up ($V_{in}=48V$, $V_{out}=5V$, $I_{out}=12A$, $T_a=+25^{\circ}C$)
Ch1=On/Off, 5V/div, Ch2= V_{out} , 2V/div

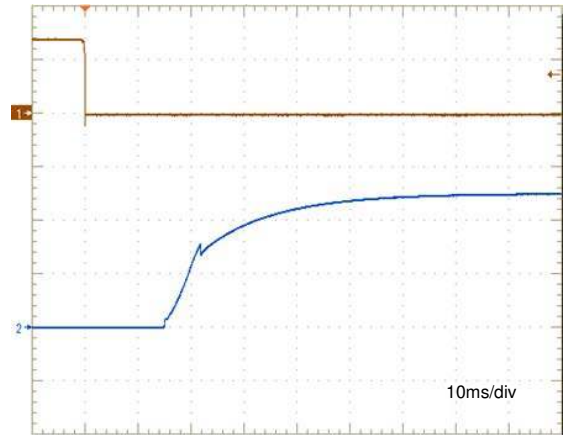

Conduction Noise ($V_{in}=48V$, $V_{out}=5V$, $I_{out}=12A$, $T_a=+25^{\circ}C$)
with External Input Filter

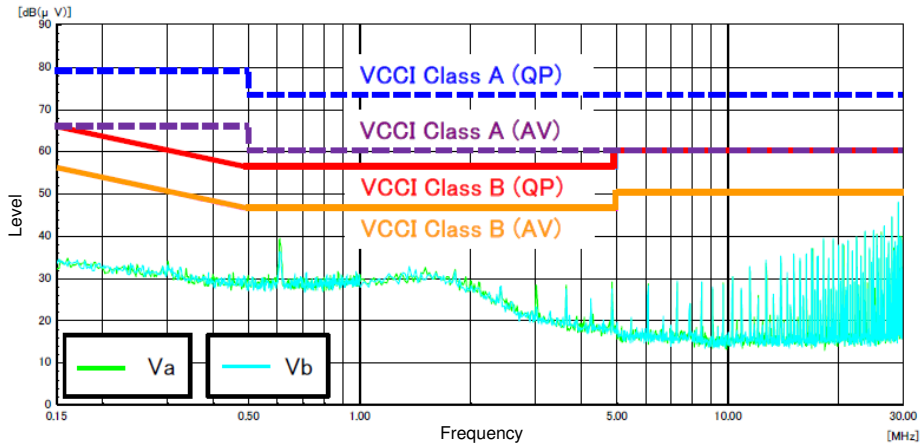

MECHANICAL SPECIFICATIONS

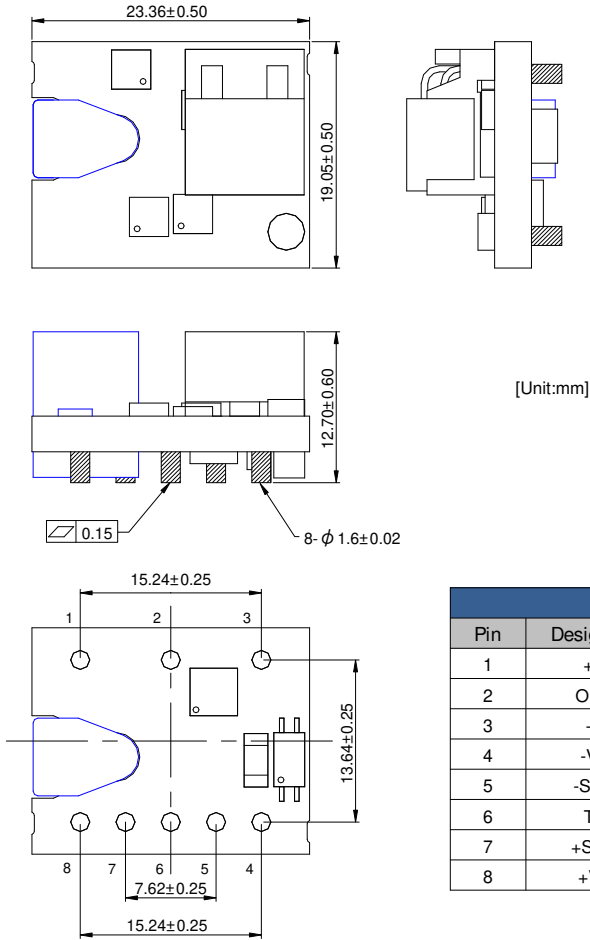

RECOMMENDED FOOTPRINT (TOP VIEW)

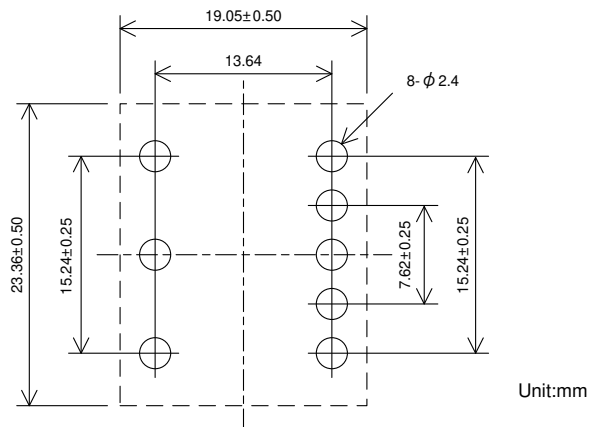

PACKAGING INFORMATION

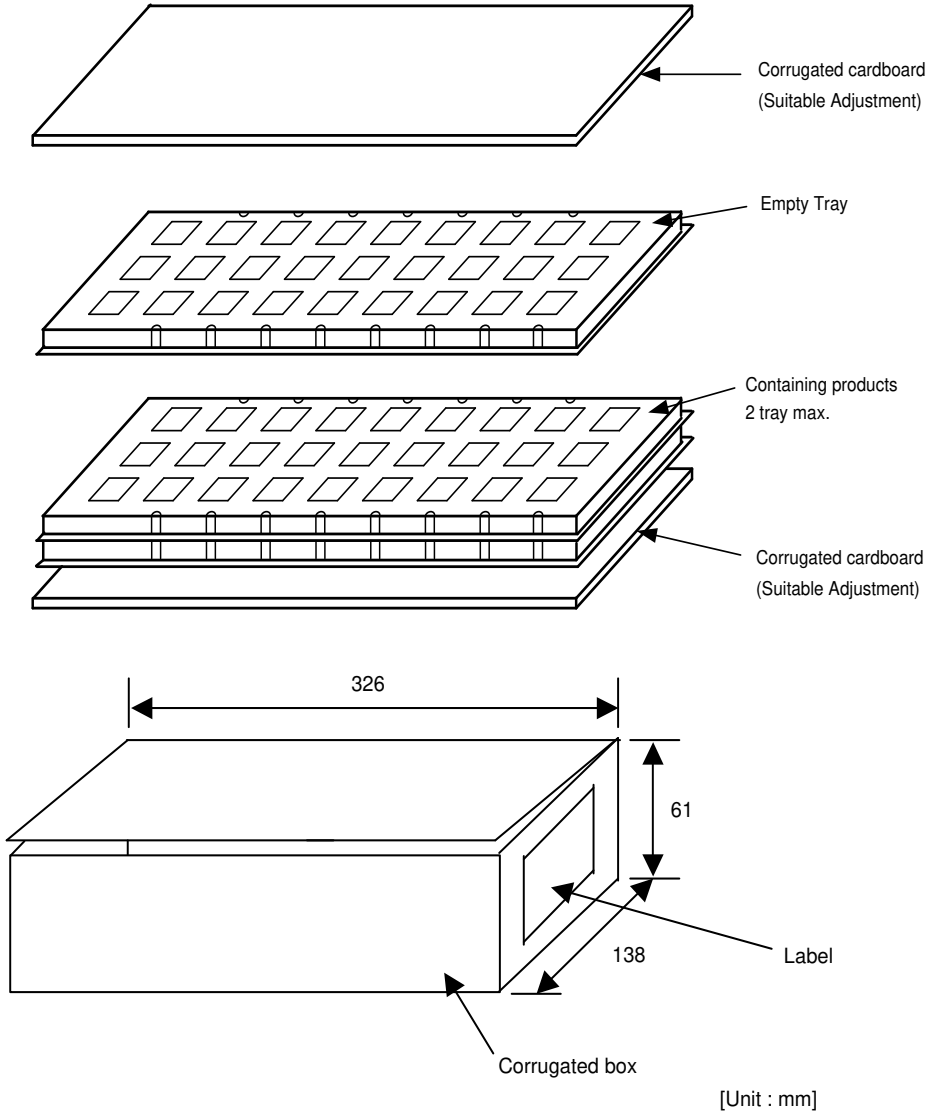

Maximum contained products : 54 pcs / box.

TECHNICAL NOTES

Over Current Protection

Over Current Protection operates with a controller circuit failure or over-load condition, and DC-DC converter will enter hiccup mode. After rejected the abnormal mode, DC-DC converter will automatically restart.

Over Voltage Protection

Output halts in hiccup mode after Output Voltage is over the value of OVP specified with failure of controller circuit. After rejected the abnormal mode, DC-DC converter will automatically restart.

On/Off Control (Negative logic)

1. On control:

On/Off(2Pin) should be connected to -Vin(3Pin), or keeps less than 0.7V.

2. Off control:

On/Off(2Pin) should be opened, or the current from On/Off(2Pin) to -Vin(3Pin) is controlled less than 30μA.

The voltage of 10V(Maximum) is output from On/Off(2Pin) when On/Off(2Pin) is opened.

Trimming Output Voltage

Resistors connected between Trim(6pin) to +Sense(7pin) will increase the output voltage ($V_{O,Trim}$) between 100% ~ 110% of the nominal output voltage($V_{O,nom}$).

$$R_{Trim-up} = \left[\frac{5.1 \times V_O (100 + \Delta)}{1.225 \times \Delta} - \frac{5.1 \times 100}{\Delta} - 10.2 \right] [k\Omega]$$

$$\Delta = \left| \frac{V_{O,Trim} - V_{O,nom}}{V_{O,nom}} \right| \times 100(\%)$$

Resistors connected between Trim(6pin) to -Sense(5pin) will decrease the output voltage($V_{O,Trim}$) between 90% ~ 100% of the nominal output voltage($V_{O,nom}$).

$$R_{Trim-down} = \left[\frac{5.1 \times 100}{\Delta} - 10.2 \right] [k\Omega]$$

$$\Delta = \left| \frac{V_{O,Trim} - V_{O,nom}}{V_{O,nom}} \right| \times 100(\%)$$

If you change output voltage, it is necessary to evaluate the characteristics of DC-DC converter at your board conditions.

Output Voltage Remote Sense

This function is capable to compensate up to 5% voltage drop between the output and the point of load. The sense trace should be short as possible using shielded wire, twisted pair wire or side by side wiring which are located closed to the PCB ground layer, etc., to reduce noise susceptibility.

If the remote sense is not needed +Sense(7Pin) should be connected to +Vout(8Pin) and -Sense(5Pin) should be connected to -Vout(4Pin).

External Input Capacitor

This capacitor minimizes the influence from the wiring to the input or the components like switch for output performance. Please evaluate the board to choose the adequate value.

Test Circuit

The initial values in Functional Specification are measured in the following test circuit.

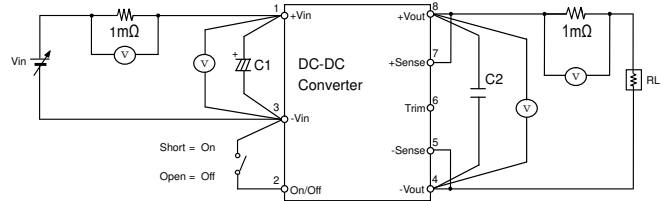

C1 : Low Impedance Electrolytic Capacitor 33μF

C2 : Ceramic Capacitor 47~400μF

RL : Electronic Load Device : ELL355 KEISOKU GIKEN equivalent

Vin : DC Power Supply :Model HP6675A KEYSIGHT equivalent

ⓧ : Digital Multimeter :Model HP34401A KEYSIGHT equivalent

When deviating from the above, DC-DC converter may operate abnormally. It should be fully confirmed on your board before use.

Ripple Noise Test

Output ripple noise is measured using designated external output components, circuits and layout as shown below.

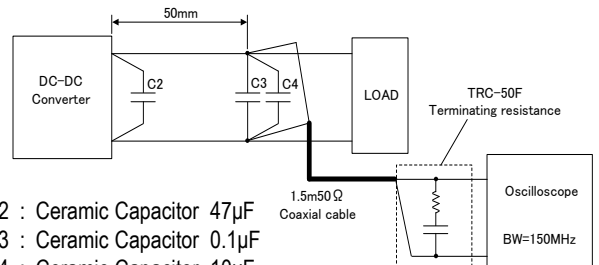

C2 : Ceramic Capacitor 47μF

C3 : Ceramic Capacitor 0.1μF

C4 : Ceramic Capacitor 10μF

Conduction Noise

The external input filter is installed and the circuit diagram is shown below.

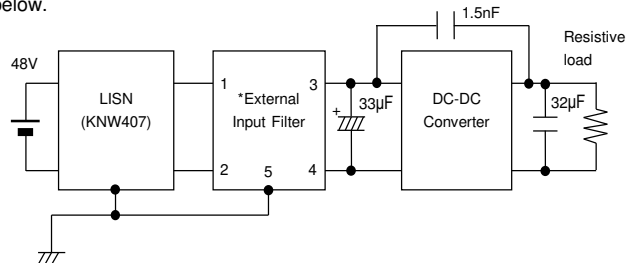

*External input filter

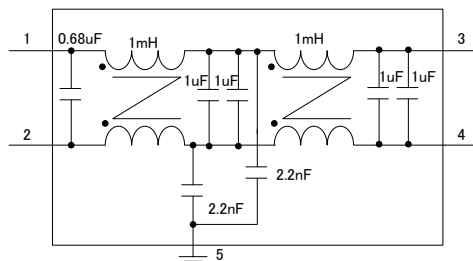

Thermal Derating Condition

The output current is limited by the derating curve. The derating curve in this datasheet illustrate typical operation under a variety of conditions.

1. Forced air cooling

DC-DC Converter is tested on a 237x237mm, 12 layers Copper evaluation board at $V_{in}=48V$. The output voltage setting is 5V (Trim pin is Open).

The Unit Under Test (UUT) is set up as shown below.

The temperature measurement points are shown below table. The temperature of measurement points should not exceed the maximum temperatures in the below table.

Position	Description	Max temperature
P1	FET	$T_{P1MAX} = 124^{\circ}C$
P2	Opto-coupler	$T_{P2MAX} = 105^{\circ}C$

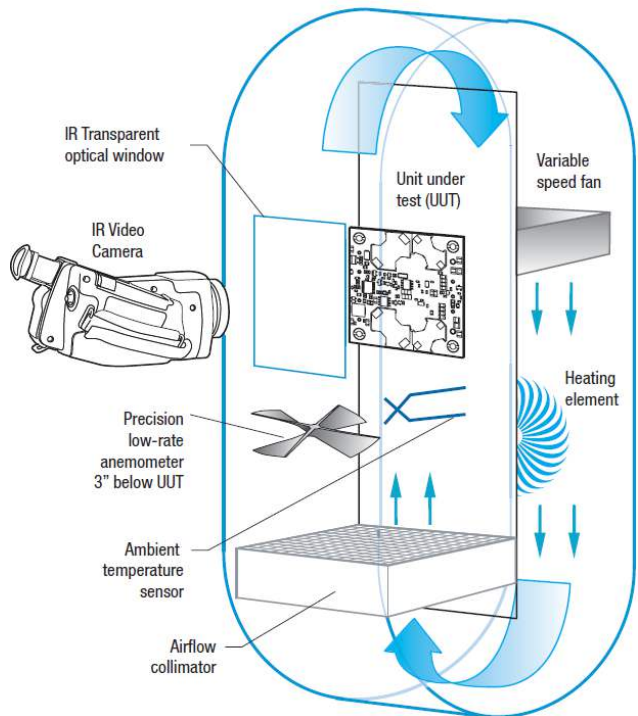
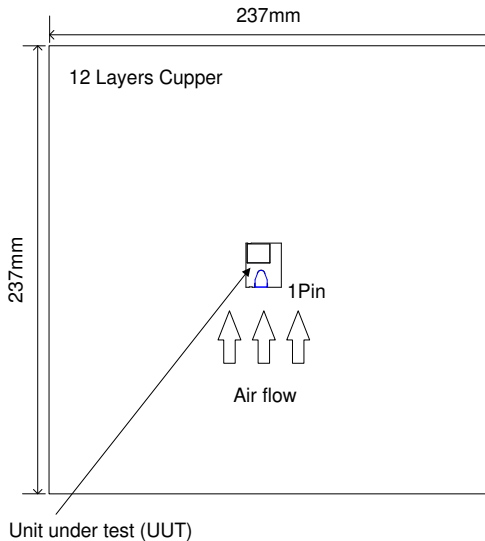
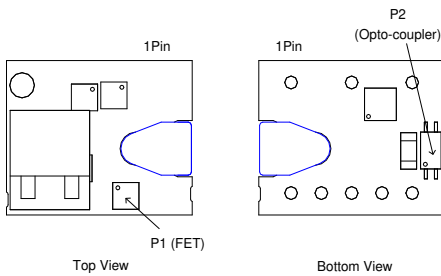

Murata employs a computer controlled custom-designed closed loop vertical wind tunnel, infrared video camera system, and test instrumentation for accurate air flow and heat dissipation analysis of power products. The system includes a precision low flow-rate anemometer, variable speed fan, power supply input and load controls, temperature gauges, and adjustable heating element. The IR camera monitors the thermal performance of the Unit Under Test (UUT) under static steady-state conditions. A special optical port is used which is transparent to infrared wave lengths. Both through-hole and surface mount converters are soldered down to a 10" x 10" host carrier board for realistic heat absorption and spreading. Both longitudinal and transverse air flow studies are possible by rotation of this carrier board since there are often significant differences in the heat dissipation in the two air flow directions. The combination of adjustable air flow, adjustable ambient heat, and adjustable Input / Output currents and voltages mean that a very wide range of measurement conditions can be studied.

The collimator reduces the amount of turbulence adjacent to the UUT by minimizing air flow turbulence. Such turbulence influences the effective heat transfer characteristics and gives false readings. Excess turbulence removes more heat from some surfaces and less heat from others, possibly causing uneven overheating. Both sides of the UUT are studied since there are different thermal gradients on each side. The adjustable heating element and fan, built-in temperature gauges, and no-contact IR camera mean that power supplies are tested in real-world conditions.

2. Conduction cooling

DC-DC Converter is tested on a 101.6x188mm, 2 layers Copper evaluation board at $V_{in}=48V$. The output voltage setting is 5V (Trim pin is Open).

The Unit Under Test (UUT) is set up as shown below.

The temperature measurement points are shown below table. The temperature of measurement points should not exceed the maximum temperatures in the below table.

Position	Description	Max temperature
P1	FET	$T_{P1MAX} = 124^{\circ}C$
P2	Opto-coupler	$T_{P2MAX} = 105^{\circ}C$
P3	Ferrite core	$T_{P3MAX} = 100^{\circ}C$

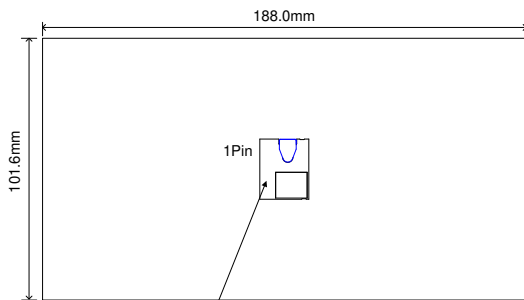
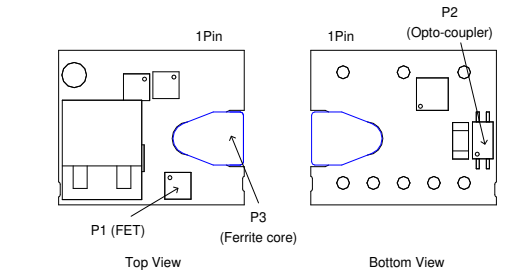

Unit under test (UUT)

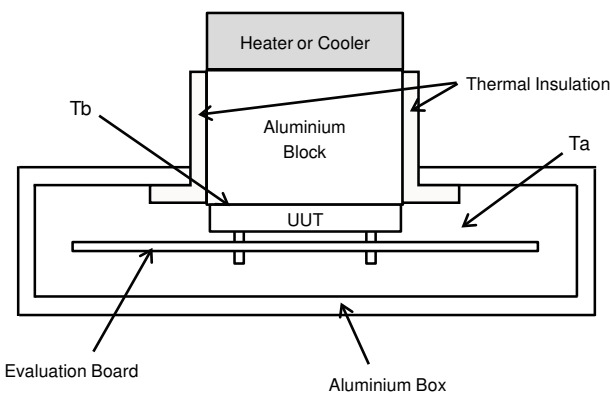

T_a : Temperature around UUT

T_b : Top surface of Ferrite core temperature

(Follow the other figure for Temperature measurement point)

* T_b is controlled separately from T_a .

SMT Reflow Soldering Guidelines

The surface-mount reflow soldering profile is shown below. This graph should be used only as a guideline.

Reflow Soldering Profiles : JEDEC IPC/JEDEC J-STD-020D

Soldering temperature	$245^{\circ}C \pm 0/-5^{\circ}C$
Soldering time	30 seconds, $240^{\circ}C-245^{\circ}C$
Heating time	60~150 seconds, $217^{\circ}C$ min.
Preheat time	60~120 seconds, $150^{\circ}C-200^{\circ}C$
Programming rate	$3^{\circ}C / \text{sec. max.}$, $217^{\circ}C-245^{\circ}C$
Descending rate	$6^{\circ}C / \text{sec. max.}$
Total soldering time	8 minutes max., $25^{\circ}C-245^{\circ}C$
Time	1time

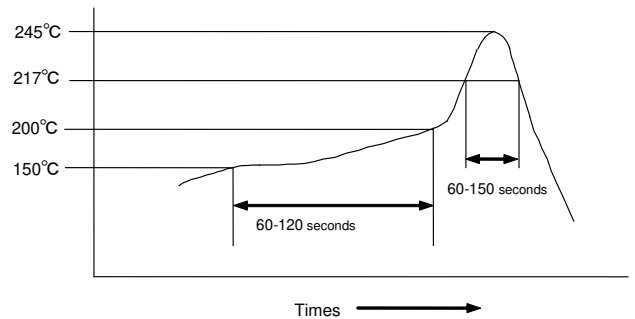

Do not vibrate for the products on reflow. Please need to take care temperature control because mounted parts may come off if the product is left under the high temperature. Do not mount on ackside of the board.

Many other factors influence the success of SMT reflow soldering. Since your production environment may differ, please thoroughly review these guidelines with your process engineers.

Functional Specifications

Please contact Murata Sales before using this product for the applications listed below. These are applications that require very high reliability of prevention of defects which might directly cause damage to third party's life, body, or property.

1. Aircraft equipment
2. Aerospace equipment
3. Undersea equipment
4. Power plant control equipment
5. Medical equipment
6. Transportation equipment (cars, buses, trucks, trains, ships, etc.)
7. Traffic signal equipment
8. Disaster prevention /crime prevention equipment
9. Data-processing equipment
10. Application of similar complexity and /or reliability listed as above.

Storage

Please store this product in an environment where the temperature/humidity is stable in the range 0 to 40degC / 10 to 75%RH and no direct sunlight. Use the product within 6 months after delivery.

Please avoid storage conditions where humidity and temperature change rapidly, as that may cause condensation on the product, which might degrade the quality of the product.

Please do not store the product environments that are dusty, in direct exposure to sea breeze, or in an atmosphere containing corrosive gas (Cl₂, NH₃, SO₂, NO_x and so on).

Operational environment and operational conditions

This product is not chemical-proof or rust-proof.

In order to prevent this product from leakage of electricity and/or abnormal temperature increase, do not use the product under the following circumstances:

- (1) in an atmosphere containing corrosive gas (Cl₂, NH₃, SO₂, NO_x and so on).
- (2) in a dusty place.
- (3) in a place exposed to direct sunlight.
- (4) in such a place where water splashes or in such a humid place where water condenses.
- (5) in a place exposed to sea breeze.
- (6) in any other places similar to the above (1)through (5).

Operational Conditions

Please use the product within specified values (power supply, temperature, input, output and load condition etc.). Input voltage drops for line impedance, so please make sure that input voltage is within in specified values.

If the product is used over the specified values, it may damage the product, reduce the quality, and even if the products can endure the condition for short time, it may cause degradation of the reliability.

Note Prior to use

If you apply high static electricity, voltage higher than rated voltage or reverse voltage to the product, it may cause defects in the products or degrade the reliability.

Please avoid the following items:

1. Over rating power supply, reverse power supply or not-enough connection of input voltage and 0V(DC)line
2. Electrostatic discharge by production line and/or operator
3. Electrified product by electrostatic induction

Do not subject product to excessive mechanical shock. If you drop the product on the floor it might cause a crack to the core of inductors and monolithic ceramic capacitors.

Also please pay attention to handling; the mounted parts can be dislodged if subjected to excessive force.

Transportation

If you transport the product, please pack it so that the package will not be damaged by mechanical vibration or mechanical shock, and please educate and guide the carrier to prevent rough handling.

Note

1. Please make sure that the product has been evaluated and confirmed against your specifications when it is mounted to your product.
2. All the items and parameters in this product specification have been prescribed on the premise that our product is used for the purpose, under the conditions and in the environment agreed upon between you and us. You are requested not to use our product deviating from such agreement.
3. We consider it not appropriate to include other terms and conditions for transaction warranty in product specifications, drawings or other technical documents. Therefore, if your technical documents as above include such terms and conditions as warranty clause, product liability clause, or intellectual property infringement liability clause, we will not be able to accept such terms and conditions unless they are based on the governmental regulation or they are stated in a separate contract agreement.



This product is subject to the following [operating requirements](#) and the [Life and Safety Critical Application Sales Policy](#):

Refer to: <https://power.murata.com/en/requirements>

Murata Manufacturing Co., Ltd makes no representation that the use of its products in the circuits described herein, or the use of other technical information contained herein, will not infringe upon existing or future patent rights. The descriptions contained herein do not imply the granting of licenses to make, use, or sell equipment constructed in accordance therewith. Spec and cautions are subject to change without notice.

© 2018 Murata Manufacturing Co., Ltd