

10119126 - X0J - XXXLF

LEAD-FREE DESIGNATION ONLY WITH APPLICABLE PLATING CODES

4-COLUMN DIFFERENTIAL SIGNAL

LETTER	PLATING (SEE NOTE 6)	
	APPLICATION	TYPE (REFERENCE)
B	TELCORDIA CO	0.76µm GOLD or GXT
C	TELCORDIA UE	1.27µm GOLD
D	TELCORDIA CO	0.76µm GOLD or GXT, LEAD-FREE
E	TELCORDIA UE	1.27µm GOLD, LEAD-FREE

NUMBER	GUIDE PIN STYLE (SEE NOTE 8)
0	STANDARD GUIDE PIN, MACHINED
1	STANDARD GUIDE PIN, ROLLED

MODULE DESCRIPTION	LETTER DESIGNATION REPRESENTED IN DASH NUMBER										BASE MODULE
	N	J	A	B	C	D	E	F	G	H	
LEFT POLARIZING GUIDANCE MODULE (SEE SHEET 6)	NO KEY NO GUIDE PIN										
RIGHT POLARIZING GUIDANCE MODULE (SEE SHEET 7)	NO KEY NO GUIDE PIN										
OPEN MODULE (TWO WALL) (SEE SHEET 2)	0 (ZERO)										
LEFT WALL MODULE (SEE SHEET 3)	L										
RIGHT WALL MODULE (SEE SHEET 4)	M										
FOUR WALL MODULE (SEE SHEET 5)	1 (ONE)										

NUMBER	CONTACT MATING WIPE LENGTH		COMPLIANT TAIL TYPE (SEE NOTE 9)
	SIGNAL	GROUND	
1	2 MM	4 MM	0.55 (0.0217") DRILL
2	3 MM	4 MM	0.55 (0.0217") DRILL
3	2 MM	4 MM	0.45 MICRO (0.0177") DRILL
4	3 MM	4 MM	0.45 MICRO (0.0177") DRILL
5	2 MM	3 MM	0.55 (0.0217") DRILL
6	3 MM	3 MM	0.55 (0.0217") DRILL
7	2 MM	3 MM	0.45 MICRO (0.0177") DRILL
8	3 MM	3 MM	0.45 MICRO (0.0177") DRILL

FOR CUSTOM-LOADED MODULES, SEE INDIVIDUAL CUSTOM DRAWINGS WITH THE DRAWING-NUMBER FORMAT OF 10119126-XXXX, WHERE: "X" DENOTES MODULE TYPE PER CHART ON THIS SHEET "YYYY" IS A SEQUENTIAL NUMBER BEGINNING WITH "0001".

	UNGROUND	GROUND
FHS	Ø2.35-Ø2.55	Ø2.35-Ø2.55
PAD	N/A	Ø5.50
PLATED	NO	YES
DRILL(mm)	2.44mm	2.58mm
DRILL(in)	0.096"	0.1015"

SCREW P/N	DESCRIPTION	BOARD THICKNESS
10091790-002LF	#2-56 X 0.375" LG. PHILIPS PANHEAD W/SQ CONICAL WASHER	1.60-5.00mm
10091790-003LF	#2-56 X 0.375" LG. PHILIPS PANHEAD W/SQ CONICAL WASHER	5.00-10.00mm

Copyright FCI. FCI

spec ref	-	dr	Mary Glass	2012/02/10	projection	MM	size	A2	scale	5:1
tolerance std	ISO 406 ISO 1101	eng	Sandar Soe	2013/03/20	chr	-	ecn no	ELX-8-14229-1	rel level	Released
surface	ISO 1302	appr	Chen-Hong Tan	2013/04/09	product family	XCEDE HD	cat. no.	10119126	rev	B
TOLERANCES UNLESS OTHERWISE SPECIFIED		www.fci.com		Product - Customer Drw		sheet 1 of 8				

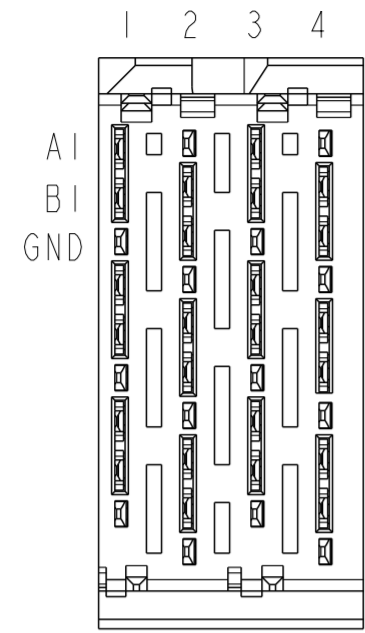

**OPEN WALL MODULE**

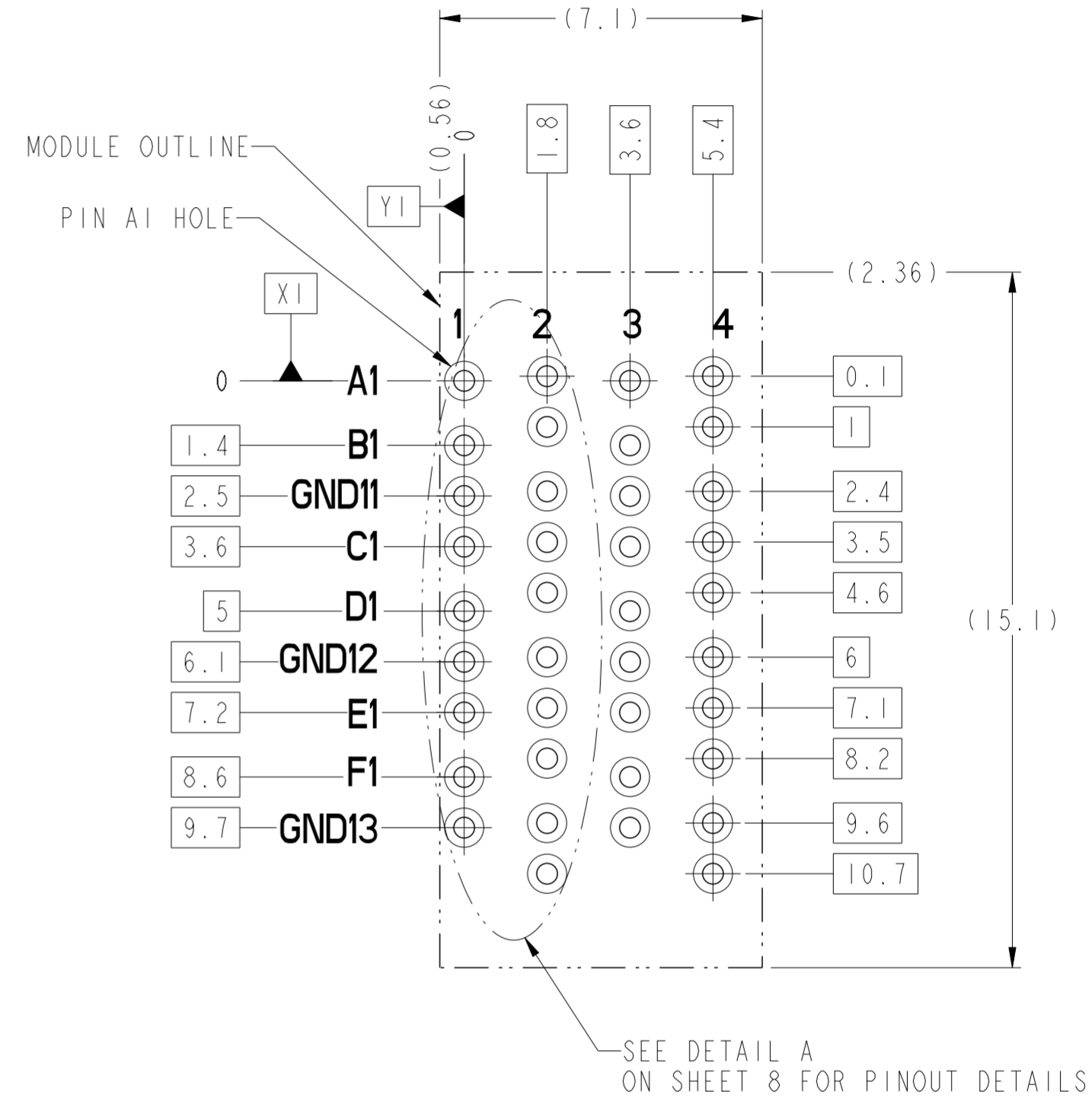
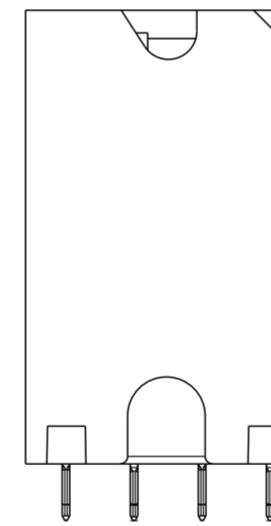
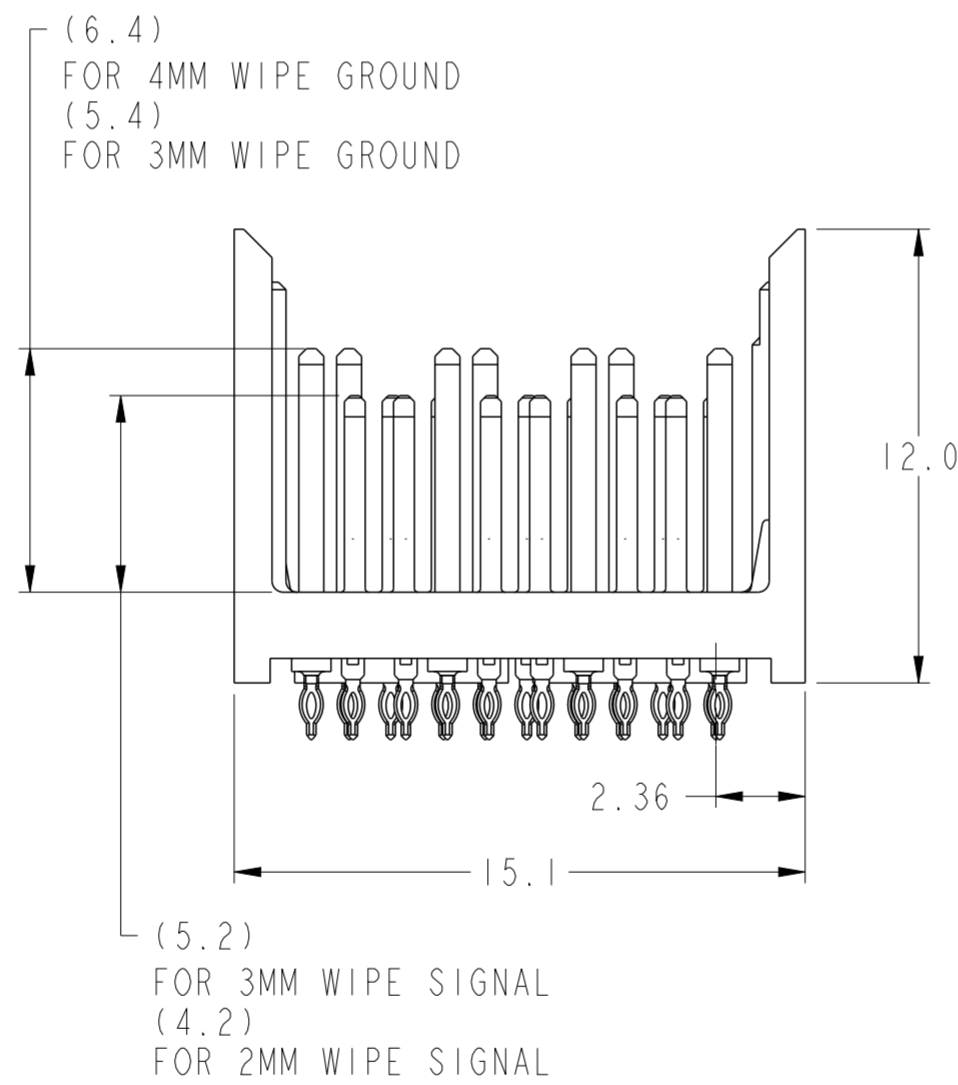
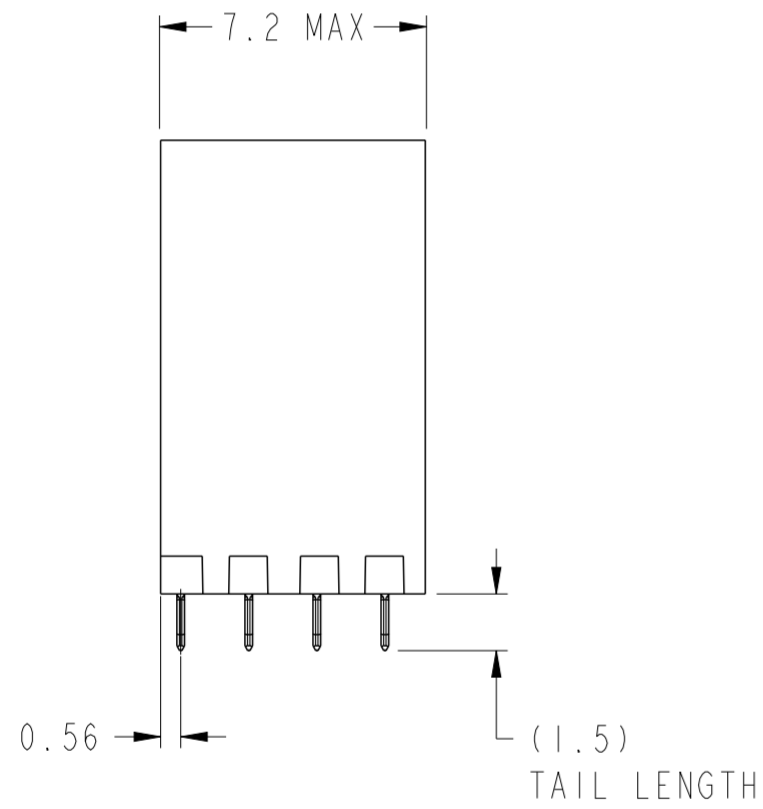
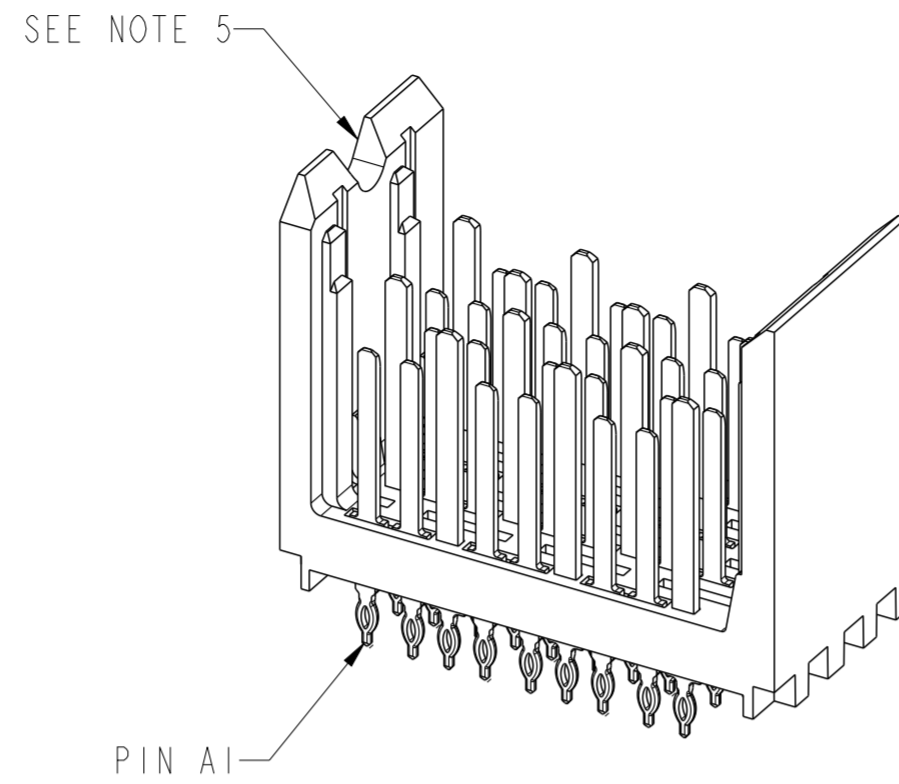

**BP HOLE PATTERN COMPONENT SIDE  
OPEN WALL MODULE BACKPLANE FOOTPRINT**



Copyright FCI.

spec ref	-	dr	Mary Glass	2012/02/10	projection	MM	size	A2	scale	3:1	
tolerance std	ISO 406 ISO 1101	eng	Sandar Soe	2013/03/20			ecn no	ELX-8-14229-1	rel level	Released	
TOLERANCES UNLESS OTHERWISE SPECIFIED		chr	-	appr							Chen-Hong Tan
surface	ISO 1302	linear	0.X	±0.3		<b>XCED HD VERTICAL HEADER</b> 3 PAIR, 4 COLUMN STITCH HEADER	dwg no 10119126	rev B	Product - Customer Drw		
		angular	0°	±2°					cat. no.	www.fci.com	sheet 2 of 8

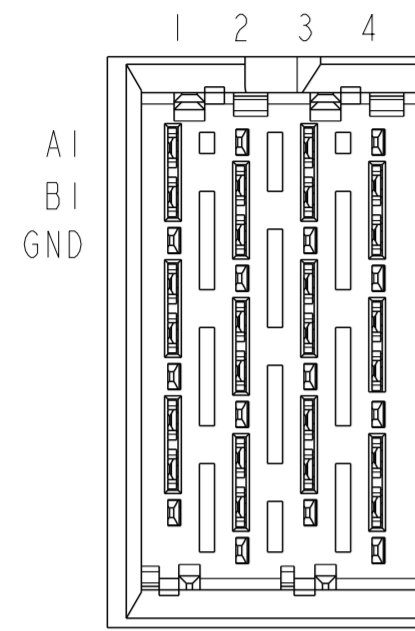

LEFT WALL MODULE

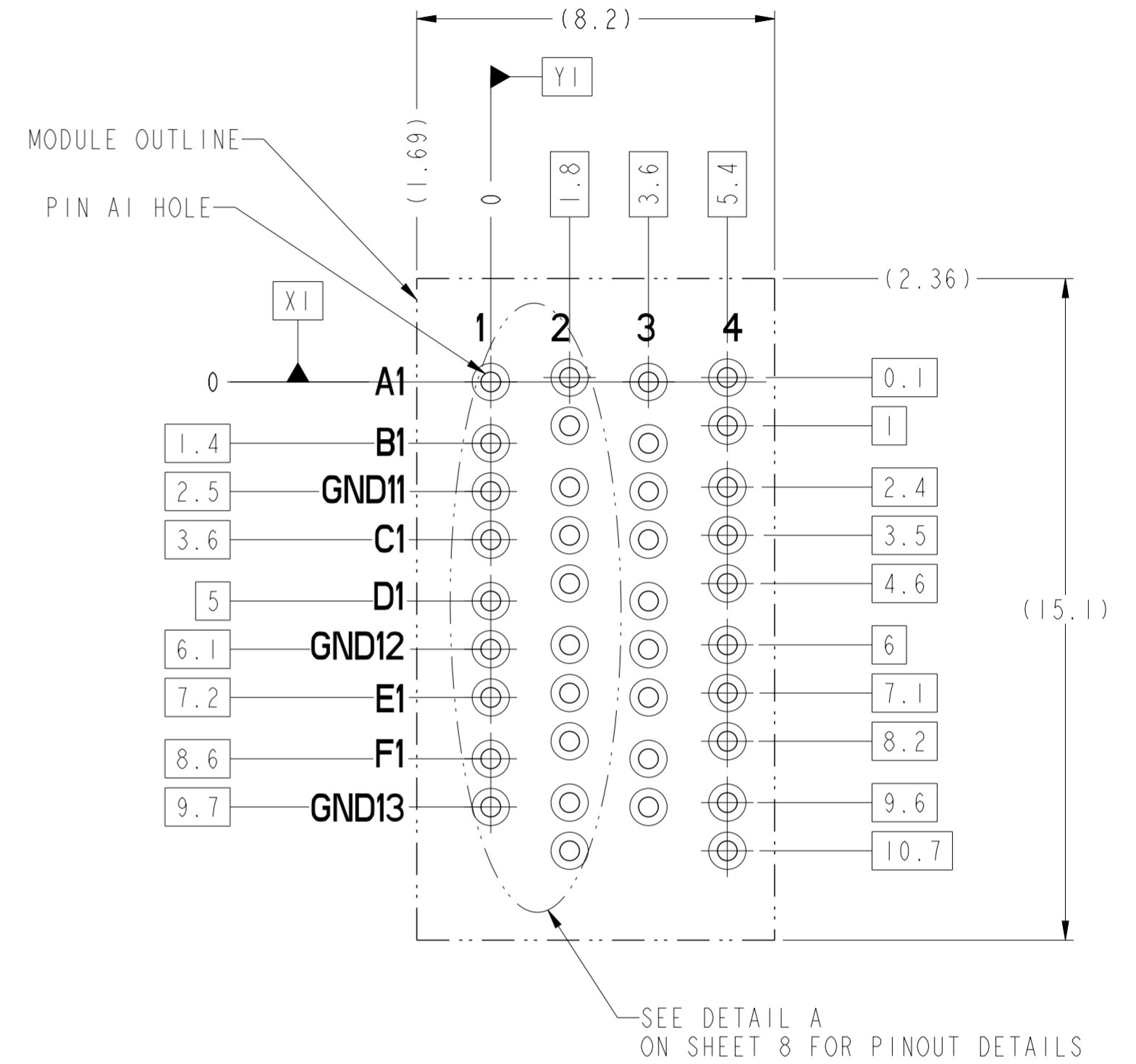
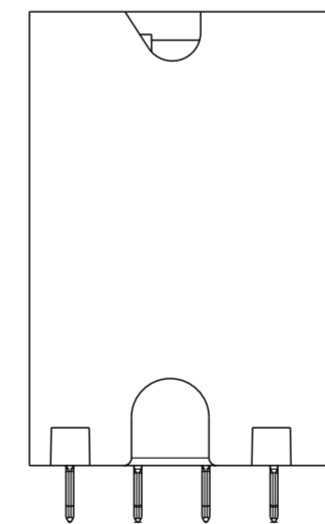
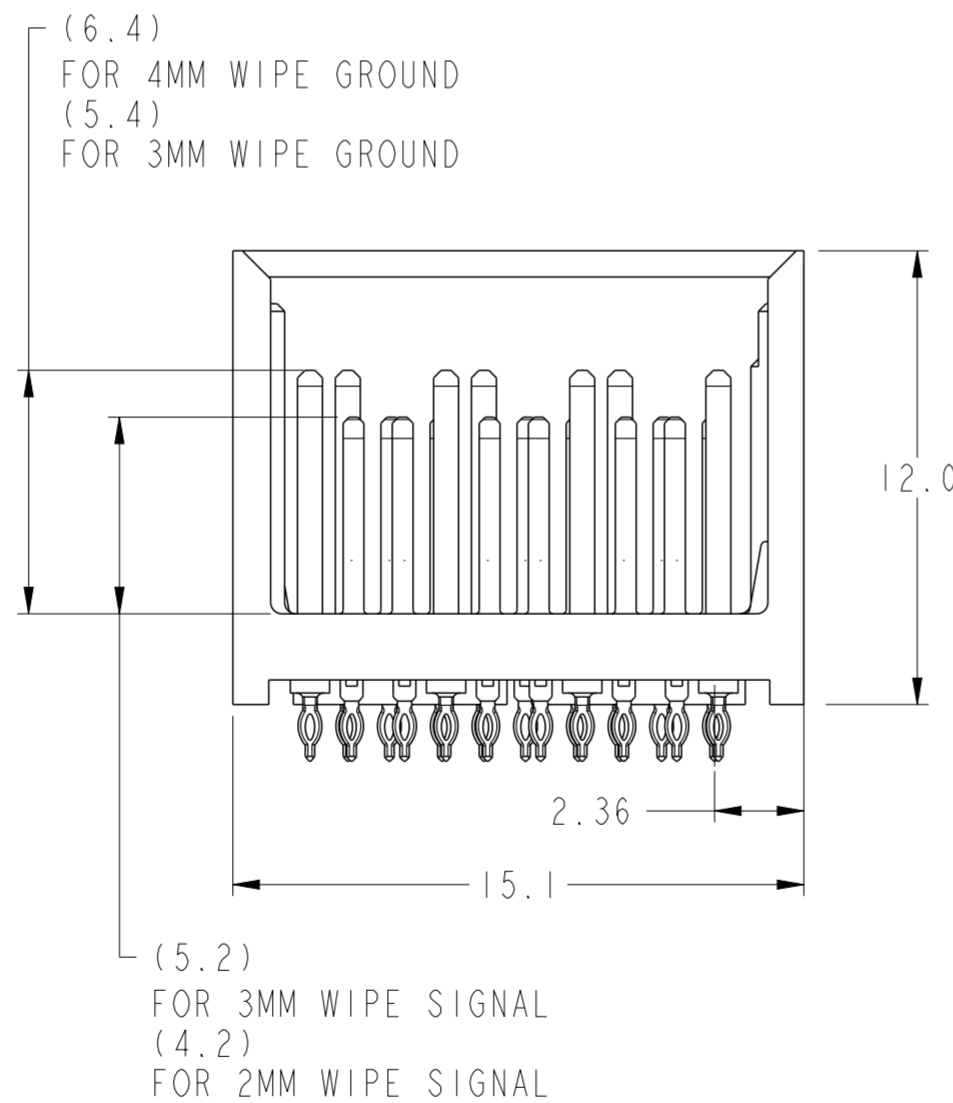
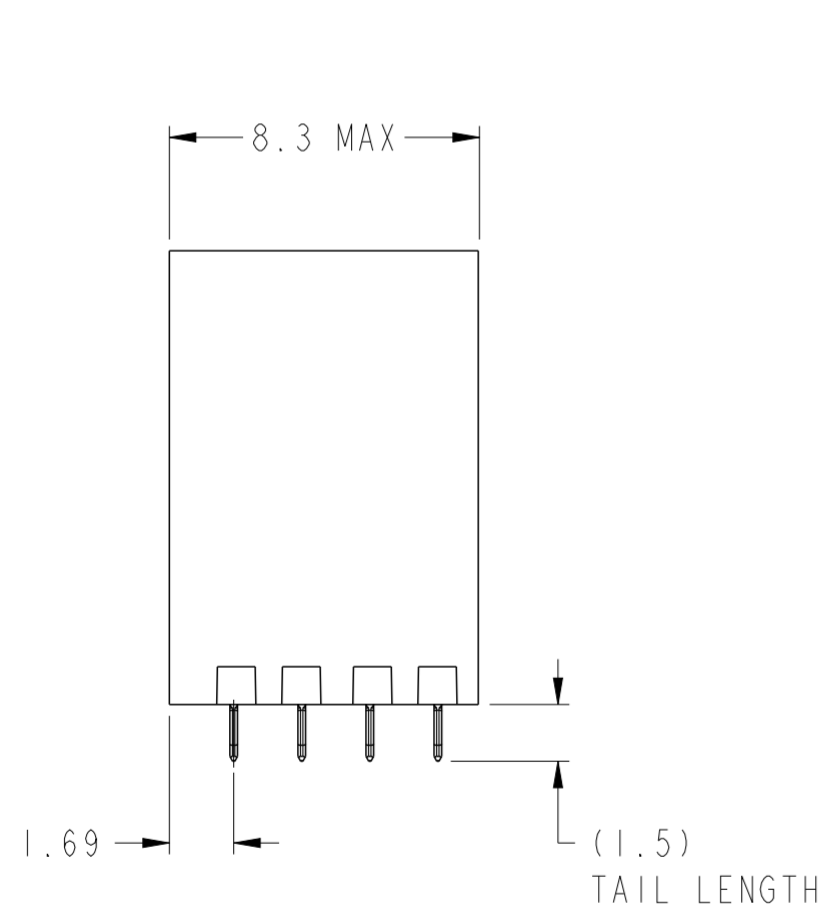
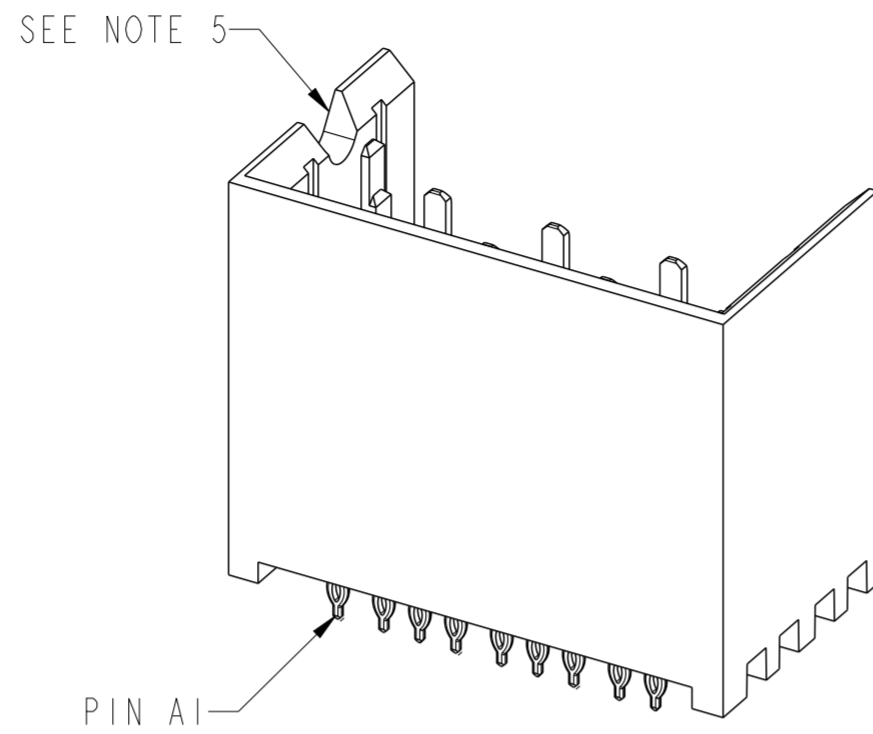

BP HOLE PATTERN COMPONENT SIDE  
LEFT WALL MODULE BACKPLANE FOOTPRINT

Copyright FCI

spec ref	-	dr	Mary Glass	2012/02/10	projection	MM	size	A2	scale	3:1
tolerance std	ISO 406 ISO 1101	eng	Sandar Soe	2013/03/20			ecn no	ELX-8-14229-1	rel level	Released
TOLERANCES UNLESS OTHERWISE SPECIFIED		chr	-	product family						
surface	ISO 1302	appr	Chen-Hong Tan	2013/04/09	product family	XCEDE HD	rel level	Released	dwg no	10119126
	linear	0.X	±0.3		title		XCEDE HD VERTICAL HEADER 3 PAIR, 4 COLUMN STITCH HEADER	rev <b>B</b>	Product - Customer Drw	
		0.XX	±0.10		cat. no.				Product - Customer Drw	sheet 3 of 8
	angular	0°	±2°		www.fci.com					

PDS: Rev :B

STATUS:Released

Printed: Apr 10, 2013

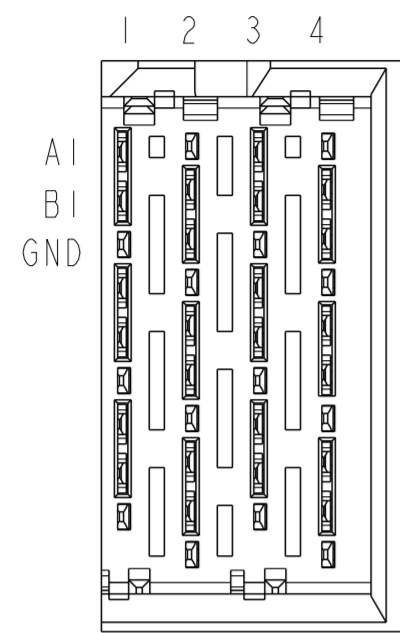

**RIGHT WALL MODULE**

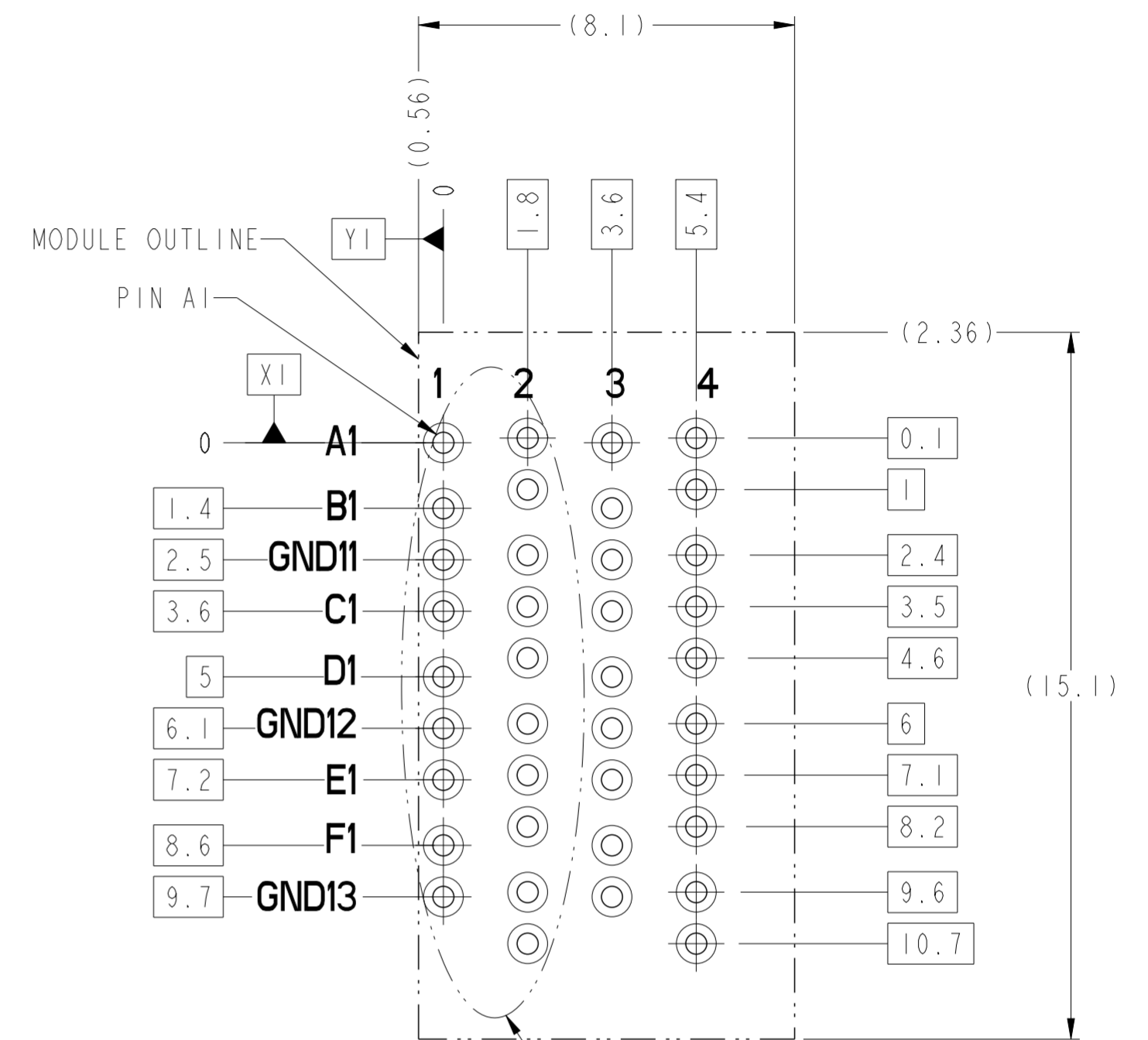
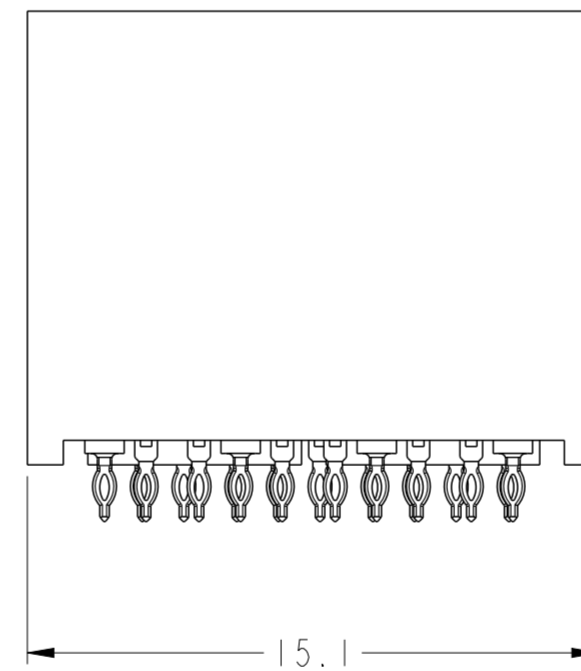
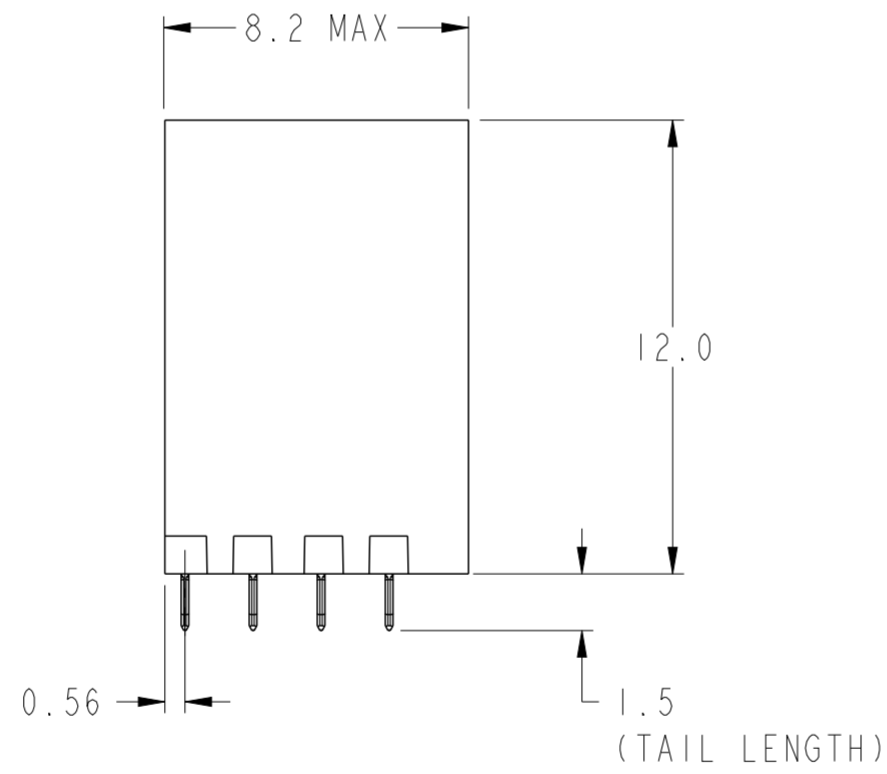
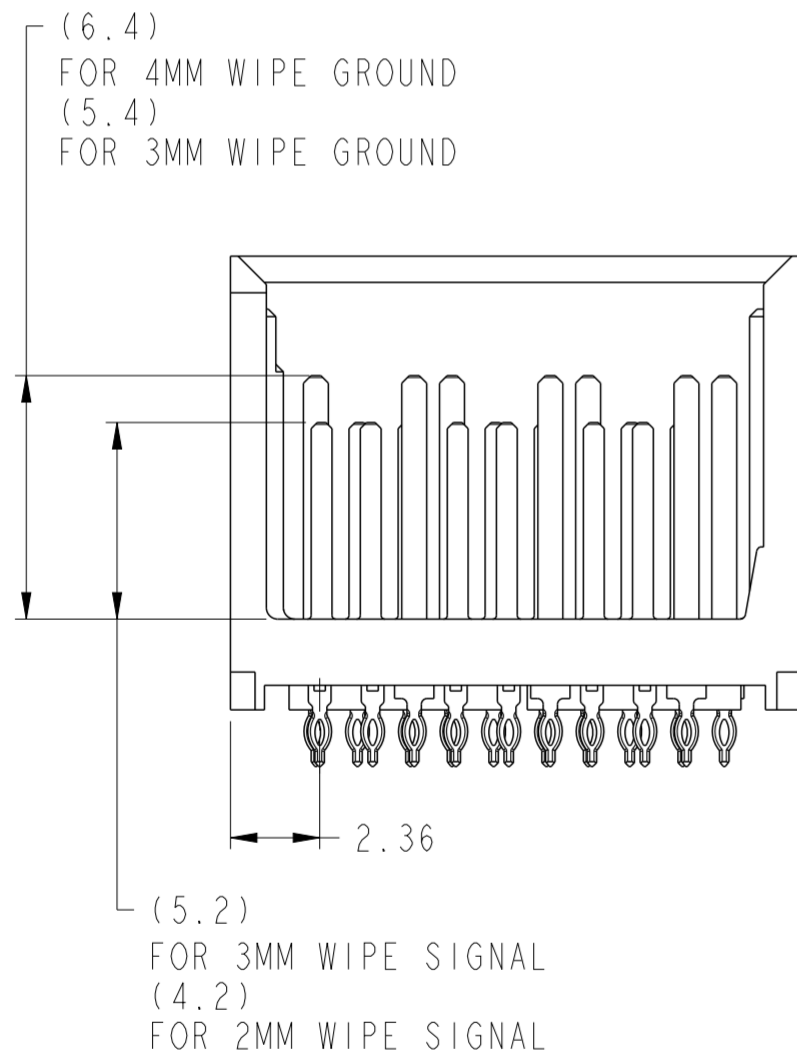
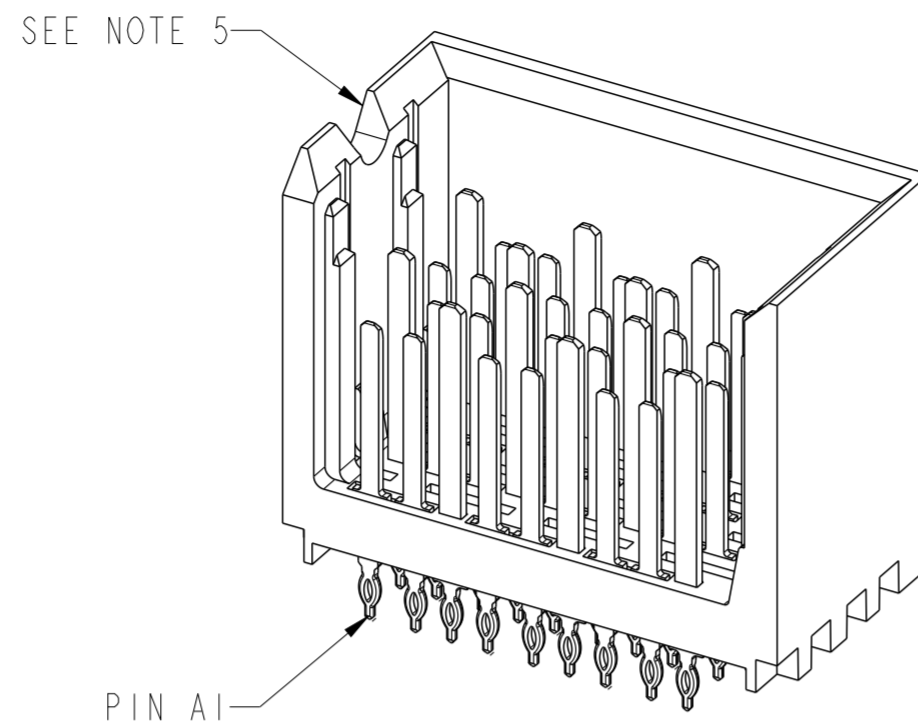

SEE DETAIL A  
ON SHEET 8 FOR PINOUT DETAILS

BP HOLE PATTERN COMPONENT SIDE

**RIGHT WALL MODULE BACKPLANE FOOTPRINT**



Copyright FCI.

spec ref	-	dr	Mary Glass	2012/02/10	projection	MM	size	A2	scale	3:1	
tolerance std	ISO 406 ISO 1101	eng	Sandar Soe	2013/03/20			ecn no	ELX-8-14229-1	rel level	Released	
TOLERANCES UNLESS OTHERWISE SPECIFIED		chr	-	appr							Chen-Hong Tan
surface	ISO 1302	linear	0.X	±0.3		<b>XCED HD VERTICAL HEADER</b> 3 PAIR, 4 COLUMN STITCH HEADER	dwg no 10119126	rev B	cat. no. -	Product - Customer Drw	sheet 4 of 8
			0.XX	±0.10							
			0.XXX	±0.05							
		angular	0°	±2°	www.fci.com						

PDS: Rev B

STATUS: Released

Printed: Apr 10, 2013

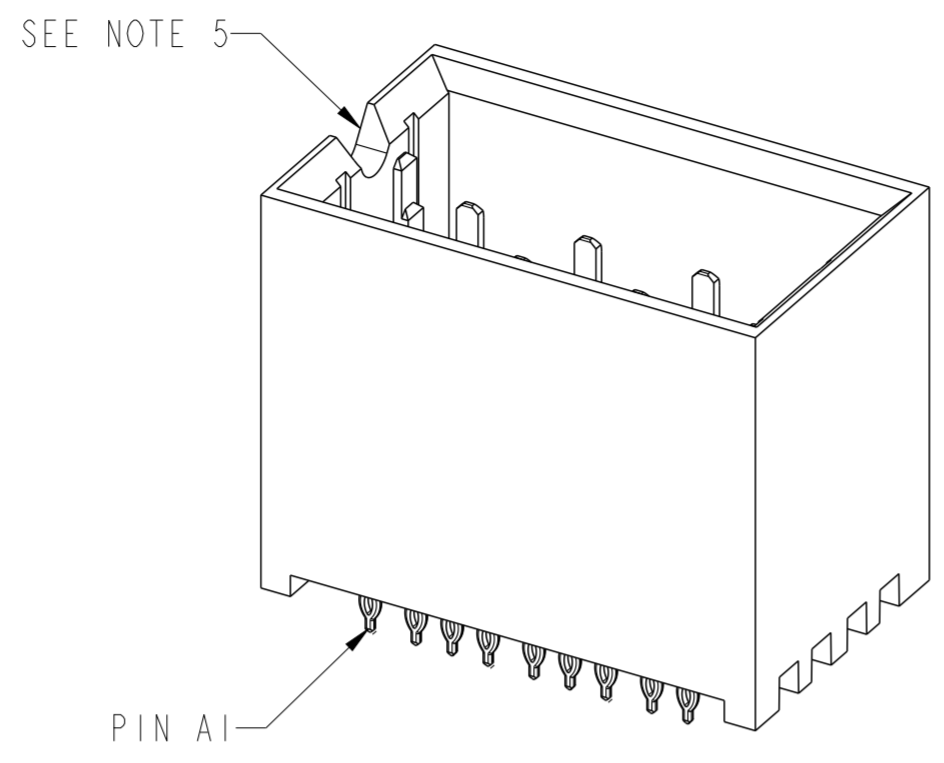
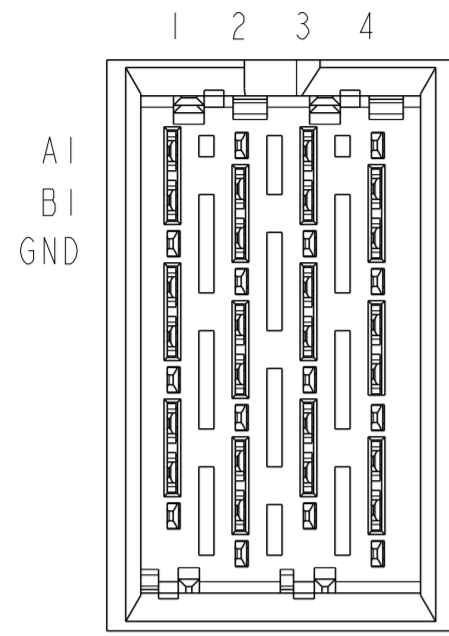

**FOUR WALL MODULE**

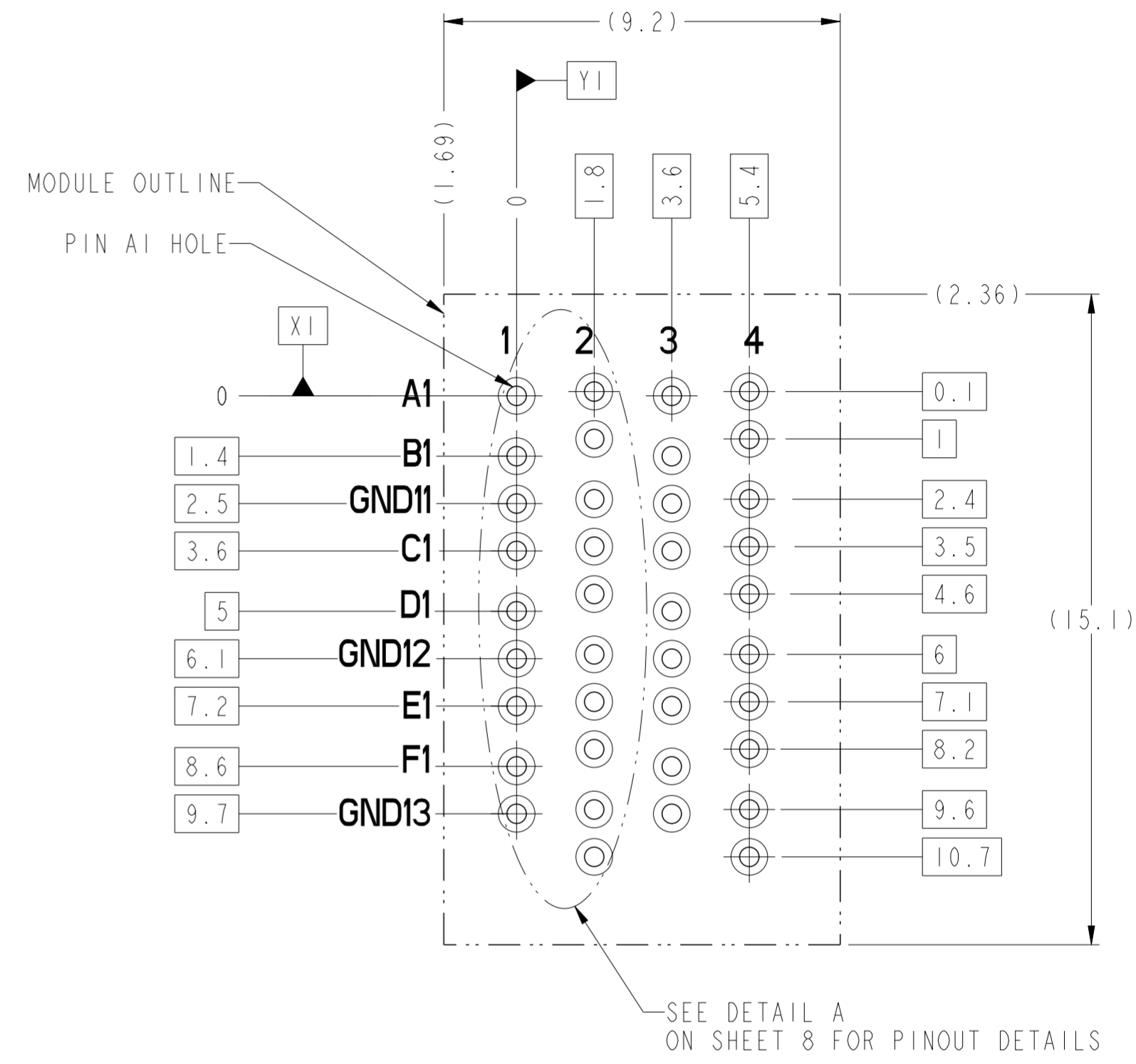

**FOUR WALL MODULE BACKPLANE FOOTPRINT**

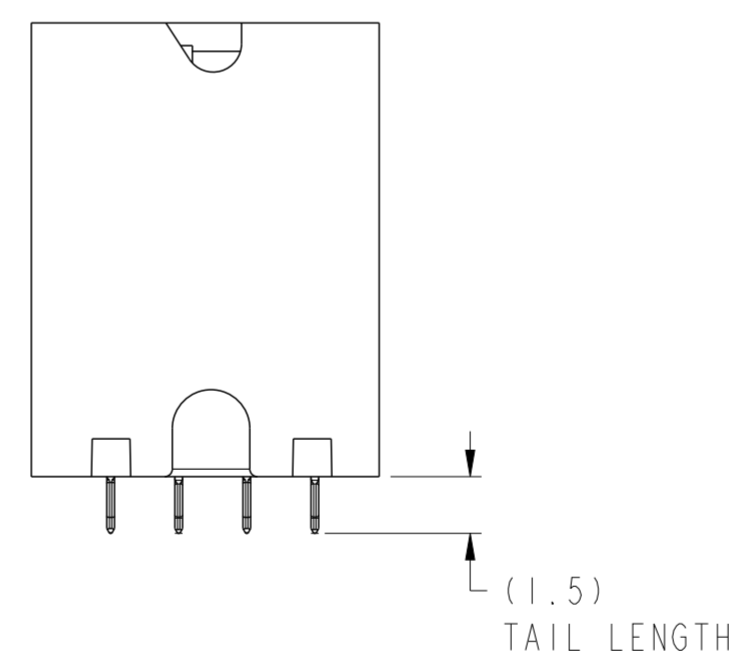
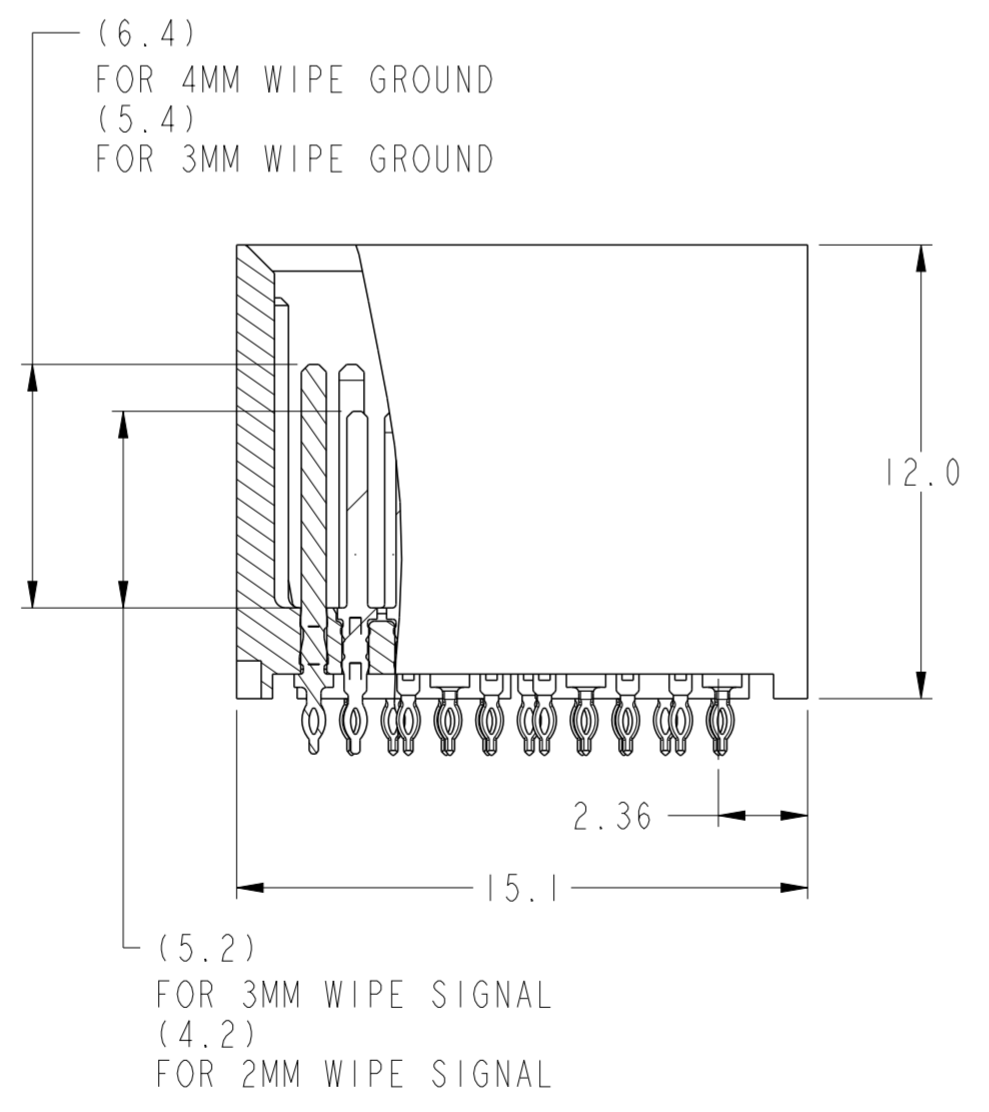
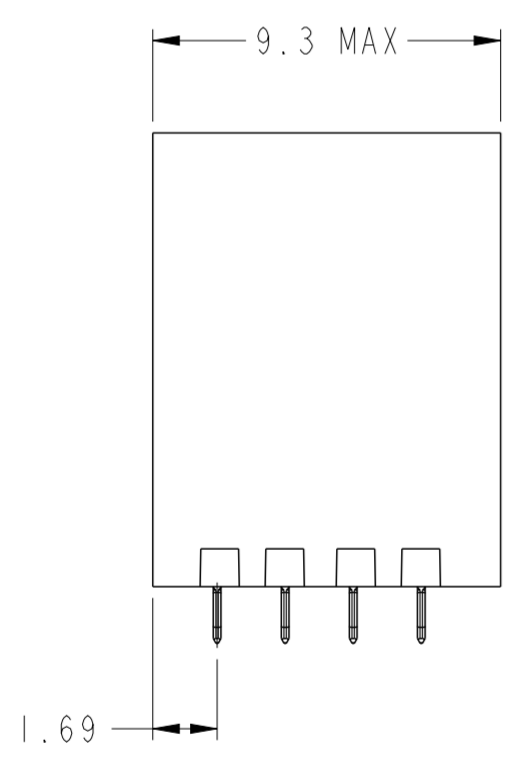

Copyright FCI.  
**FCI**

spec ref	-	dr	Mary Glass	2012/02/10	projection	MM	size	A2	scale	3:1
tolerance std	ISO 406 ISO 1101	eng	Sandar Soe	2013/03/20			ecn no	ELX-S-14229-1		
	TOLERANCES UNLESS OTHERWISE SPECIFIED	chr	-	rel level				Released		
surface	ISO 1302	appr	Chen-Hong Tan	2013/04/09	product family	XCEDE HD	rel level	Blue		
linear	0.X ±0.3 0.XX ±0.10 0.XXX ±0.05	FCI	<b>XCEDE HD VERTICAL HEADER</b> 3 PAIR, 4 COLUMN STITCH HEADER		cat. no.	10119126	rev	<b>B</b>		
angular	0° ±2°	www.fci.com	Product - Customer Drw		sheet 5 of 8					

PDS: Rev :B

STATUS:Released

Printed: Apr 10, 2013

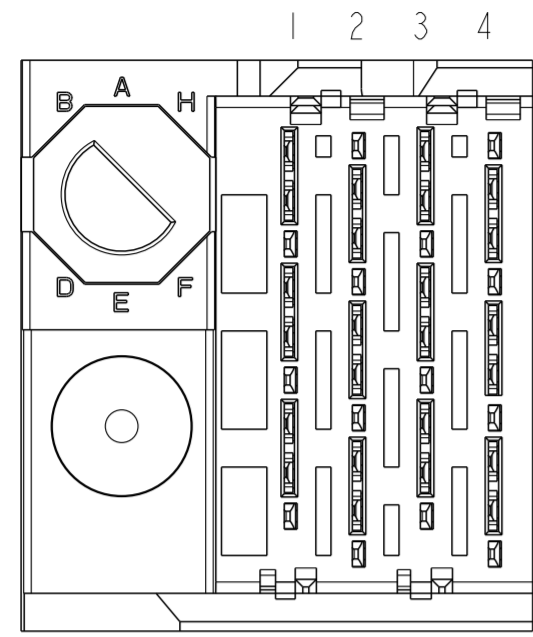

LEFT POLARIZING / GUIDE MODULE

OPTIONAL KEY SEE SHEET 1  
PART NUMBER TREE

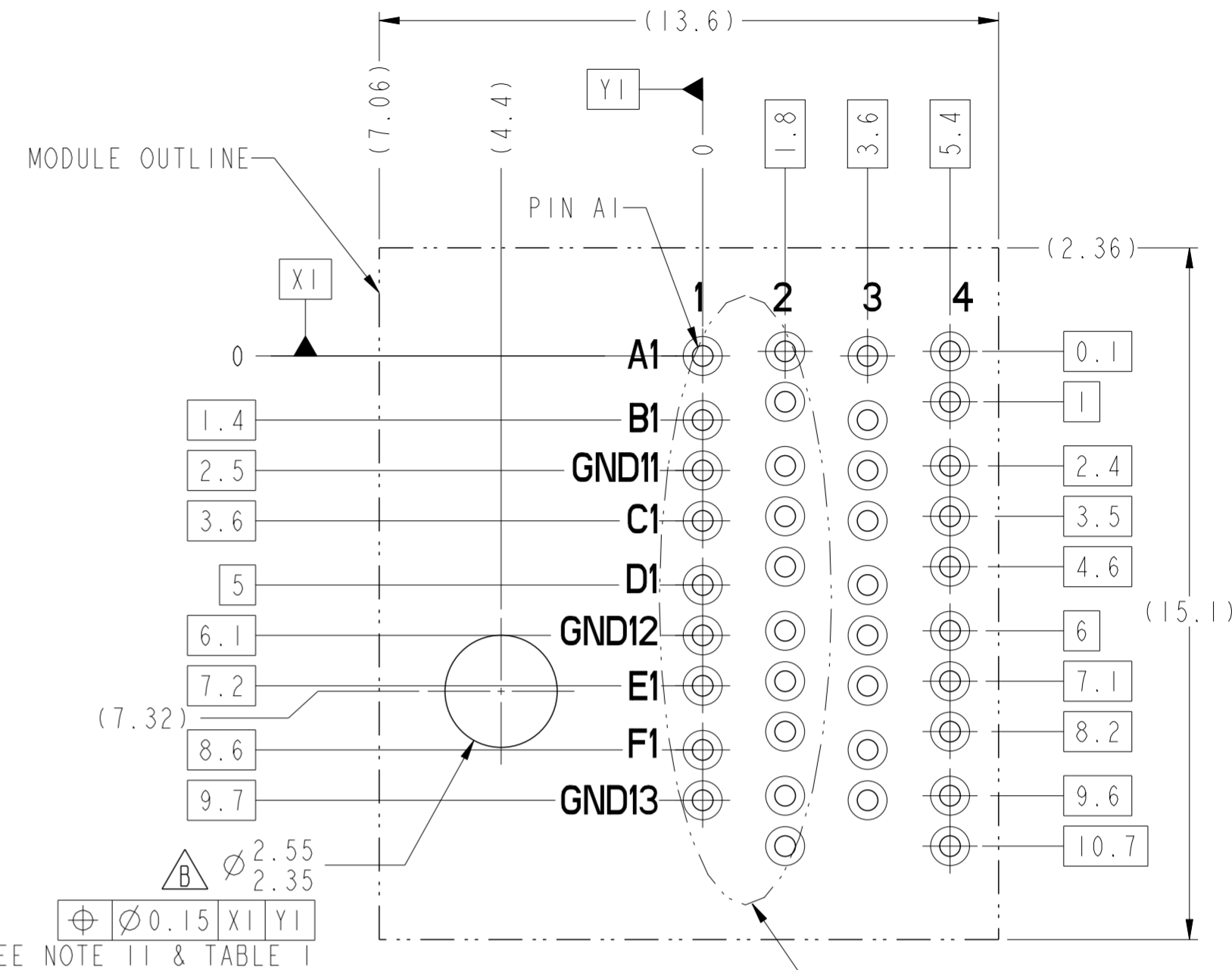
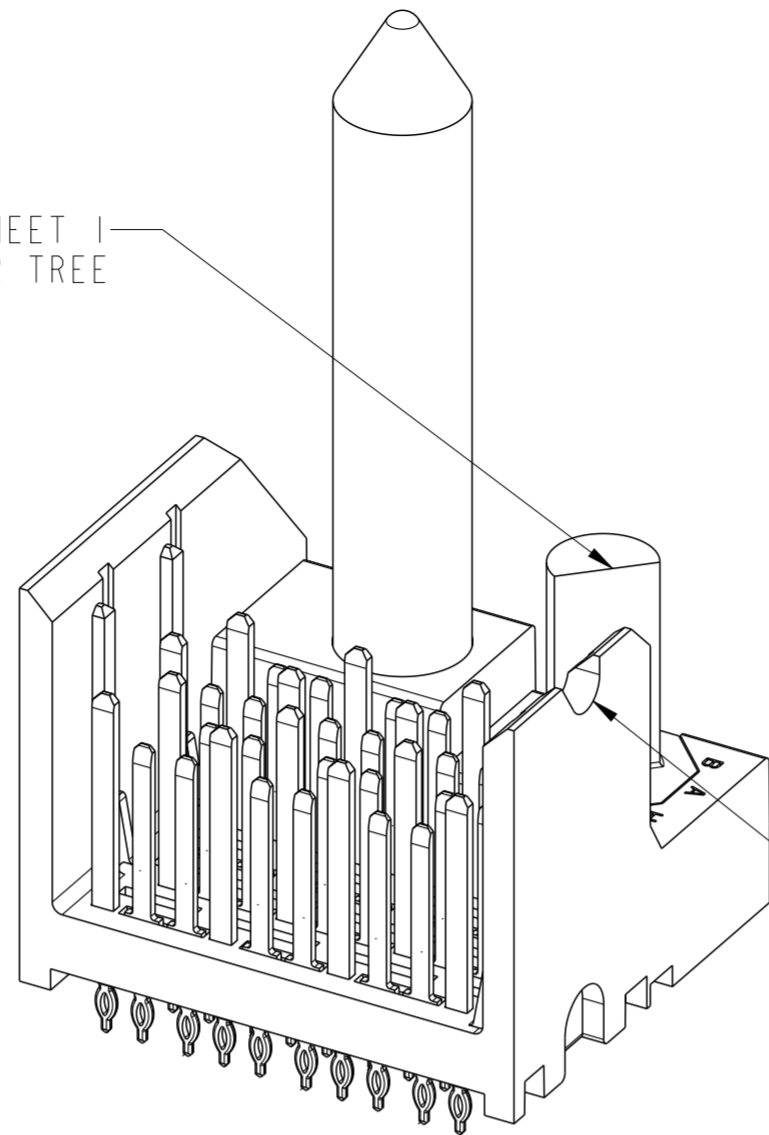

BP HOLE PATTERN COMPONENT SIDE

LEFT POLARIZING / GUIDE MODULE  
BACKPLANE FOOTPRINT

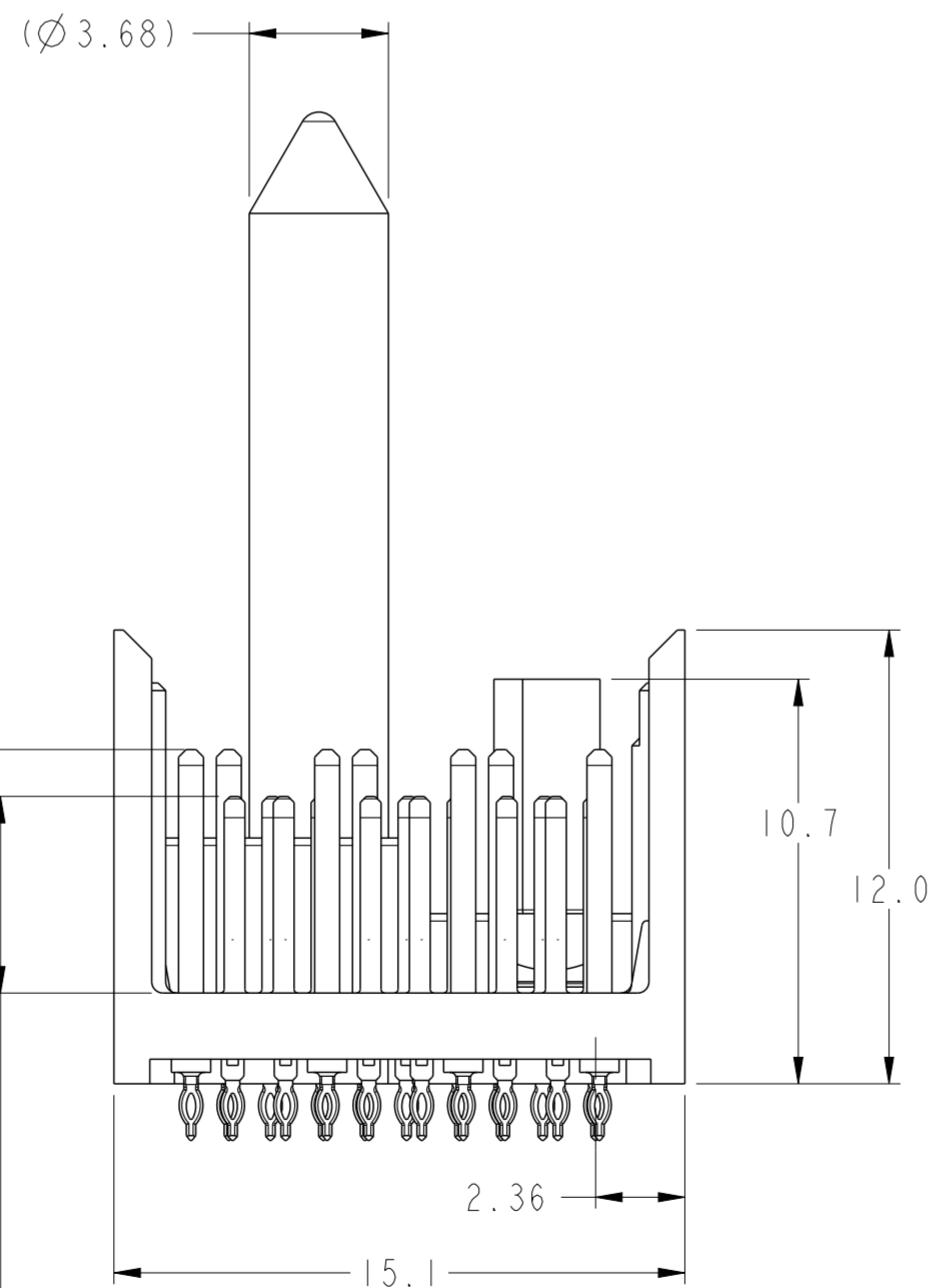
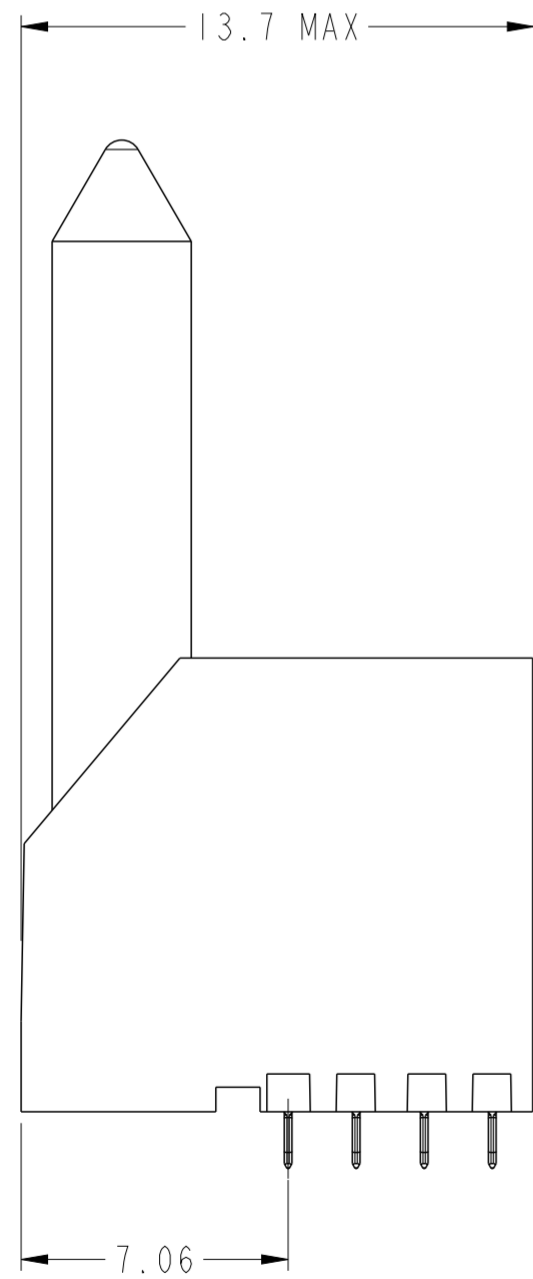

(5.2)  
FOR 3MM WIPE SIGNAL  
(4.2)  
FOR 2MM WIPE SIGNAL  
(6.4)  
FOR 4MM WIPE GROUND  
(5.4)  
FOR 3MM WIPE GROUND

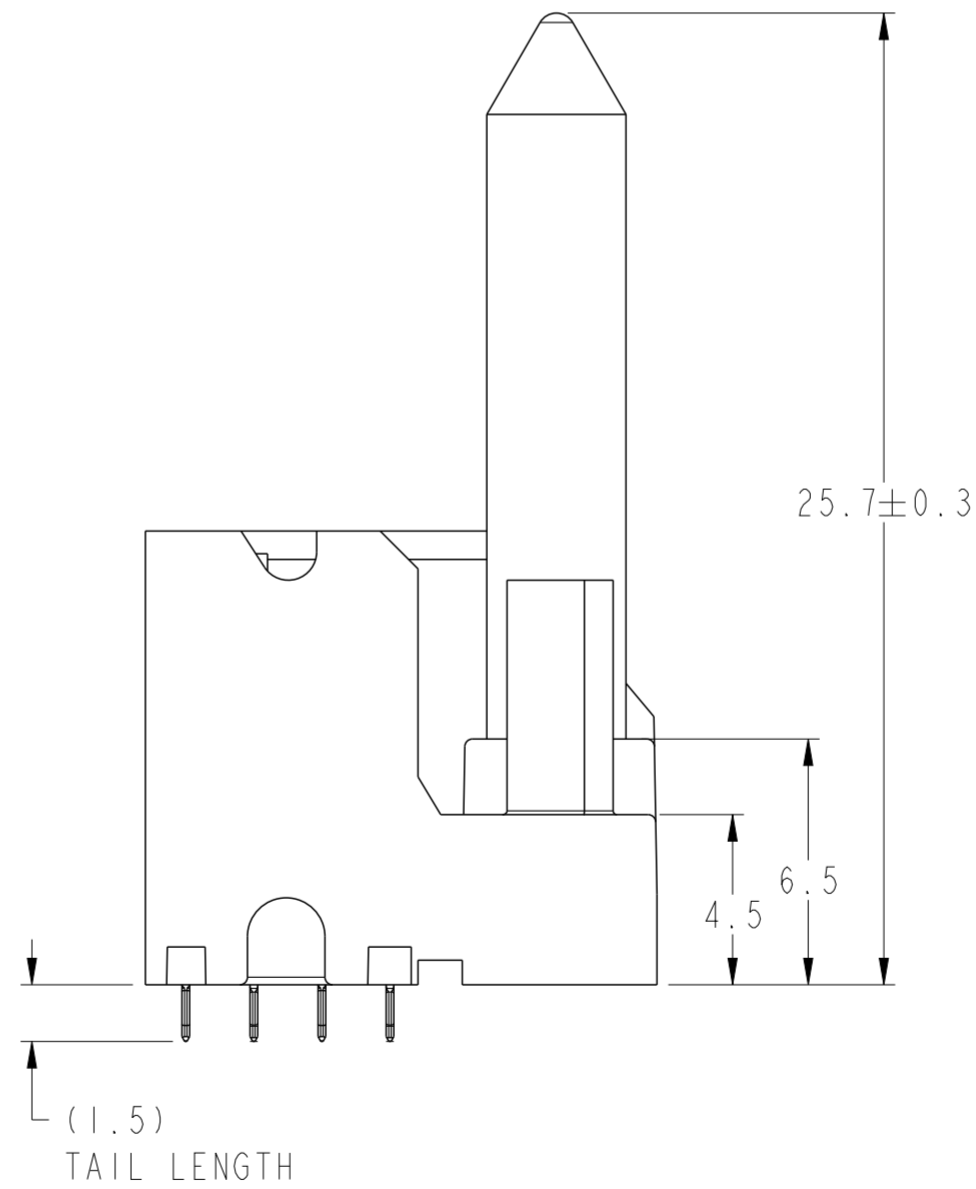

spec ref	-	dr	Mary Glass	2012/02/10	projection	MM	size	A2	scale	5:1
tolerance std	ISO 406 ISO 1101	eng	Sandar Soe	2013/03/20			ecn no	ELX-8-14229-1		
surface	ISO 1302	chr	-	appr			Chen-Hong Tan	2013/04/09	product family	XCEDE HD
linear	0.X ±0.3 0.XX ±0.10 0.XXX ±0.05	angular	0° ±2°			<b>FCI</b> XCEDE HD VERTICAL HEADER 3 PAIR, 4 COLUMN STITCH HEADER	cat. no. -	Product - Customer Drw	sheet 6 of 8	rev <b>B</b>

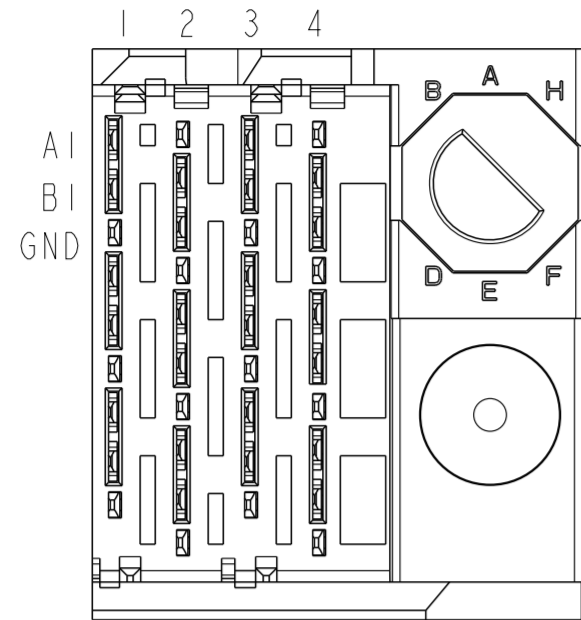

**RIGHT POLARIZING / GUIDE MODULE**

OPTIONAL KEY SEE SHEET 1  
PART NUMBER TREE

SEE NOTE 5

PIN AI

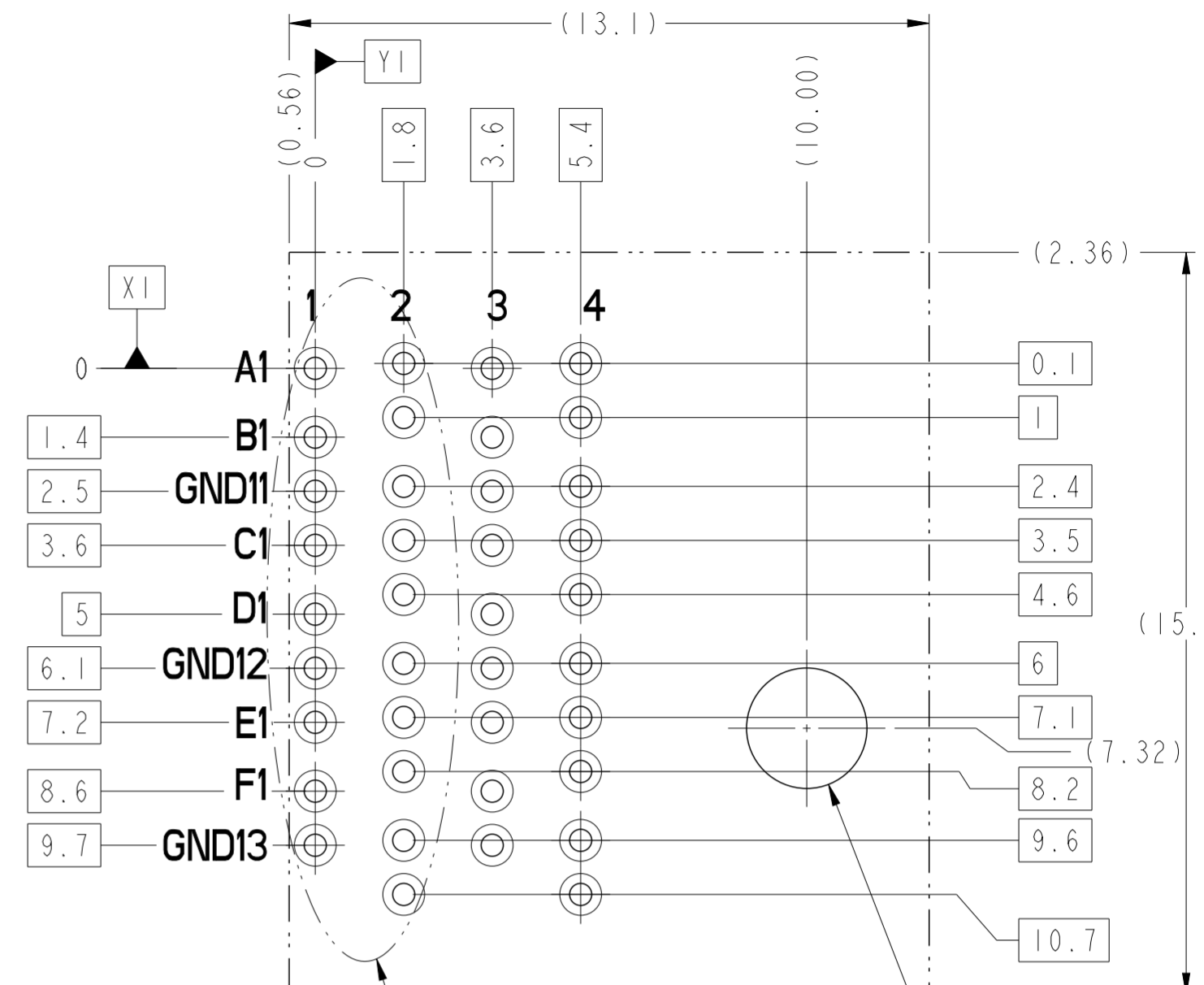
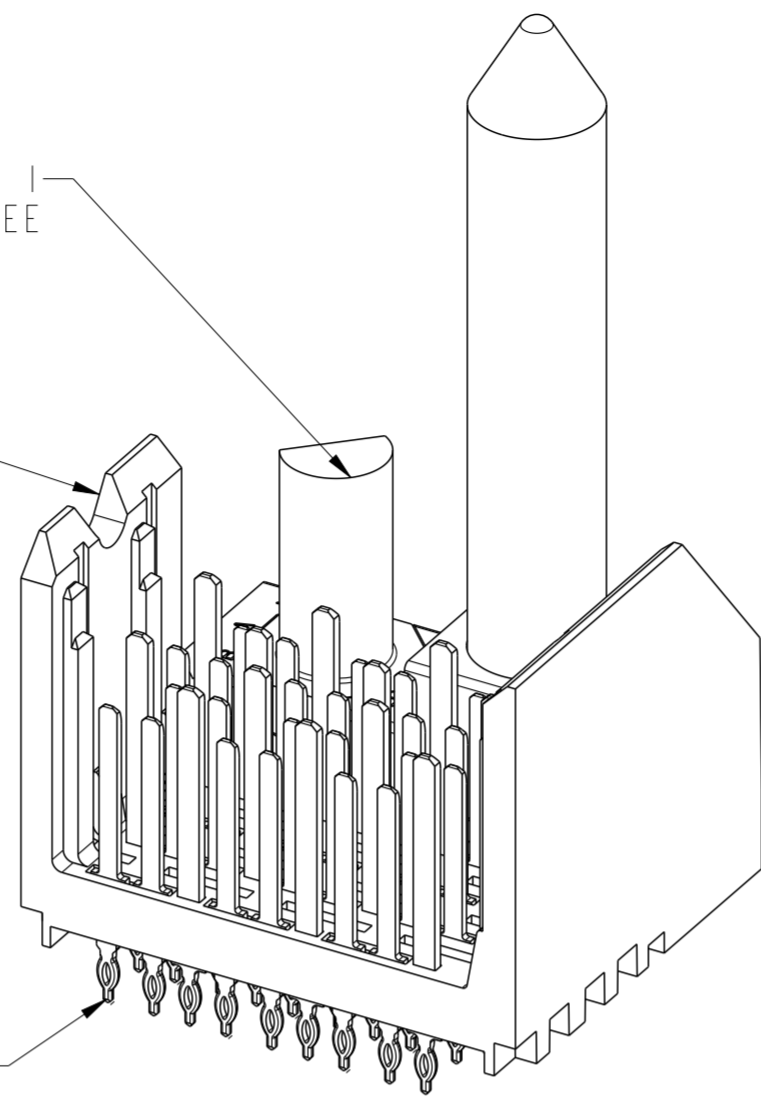

SEE DETAIL A  
ON SHEET 8 FOR  
PINOUT DETAILS

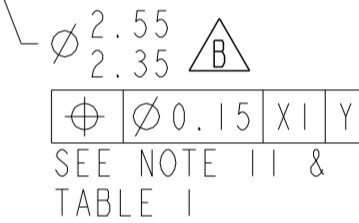

BP HOLE PATTERN COMPONENT SIDE

**RIGHT POLARIZING / GUIDE MODULE  
BACKPLANE FOOTPRINT**

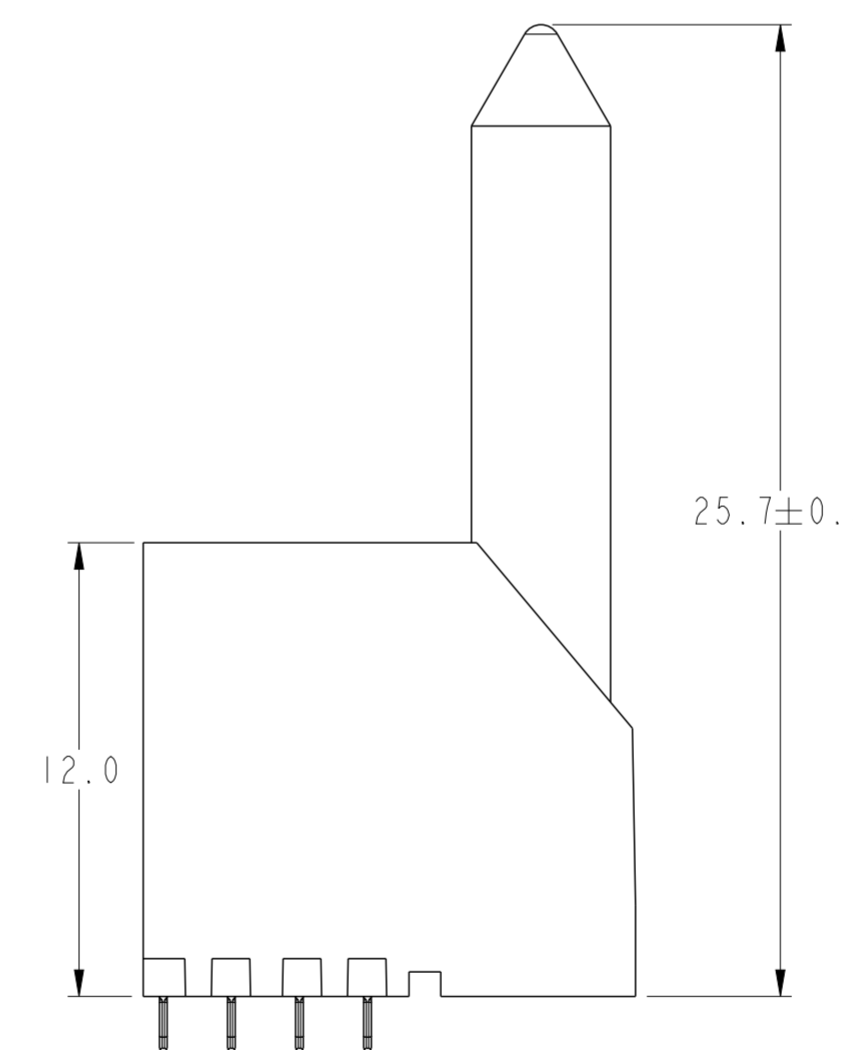
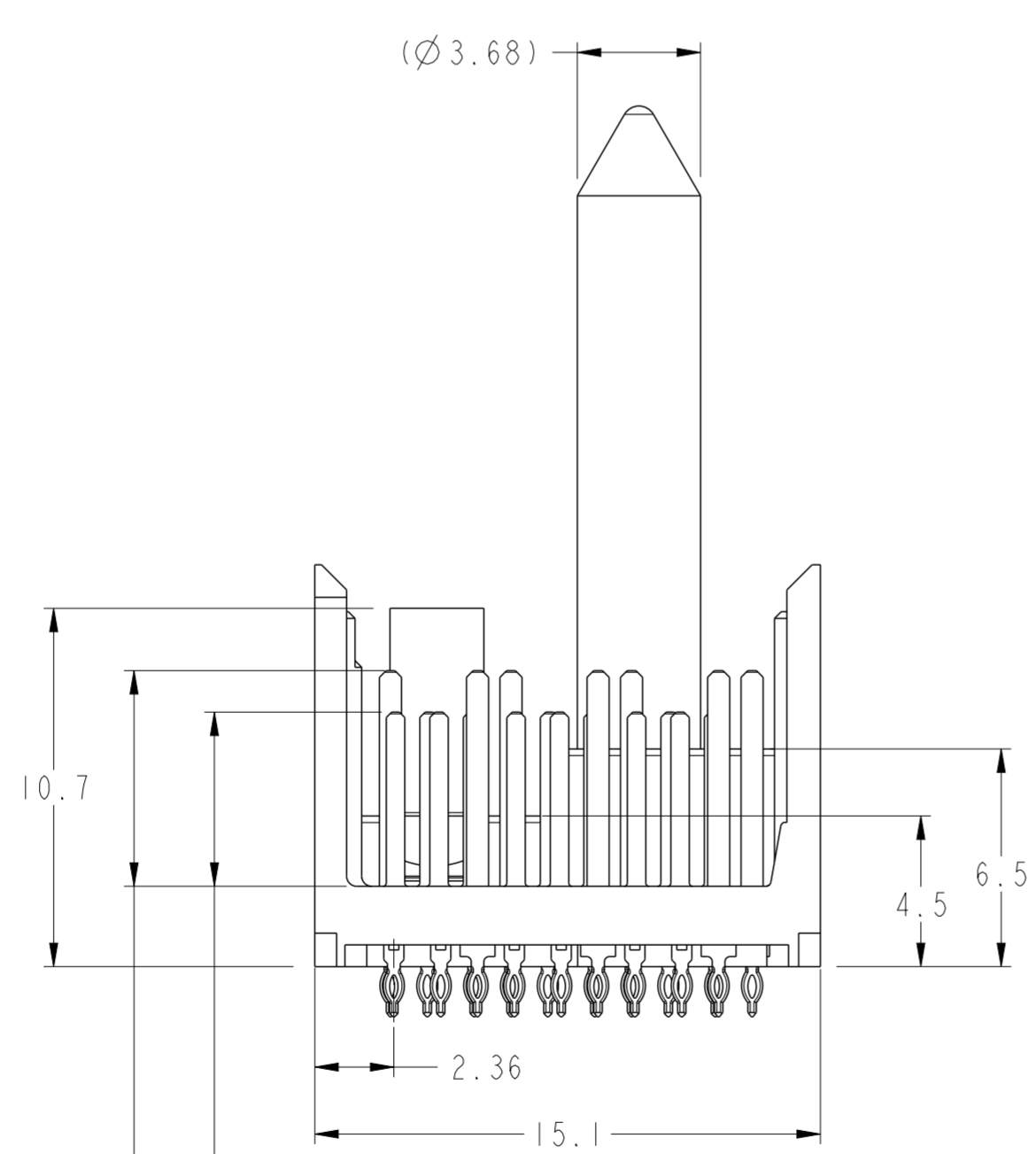
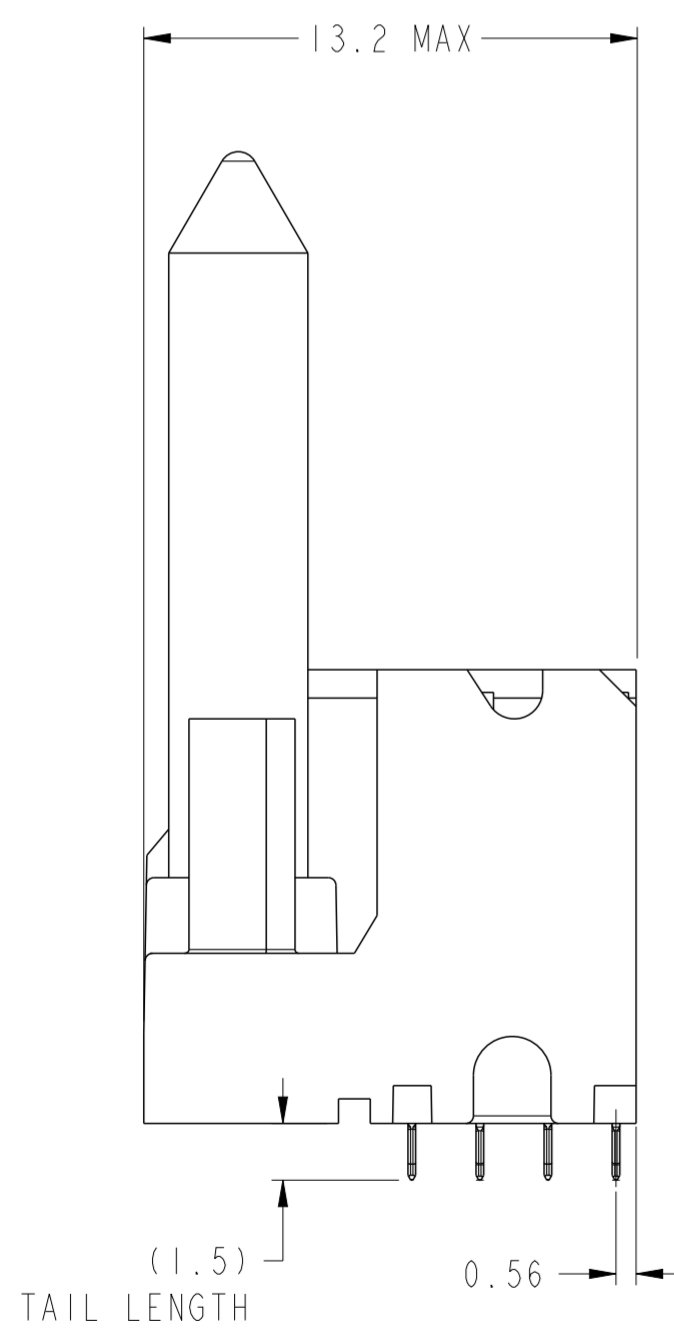

(5.2)  
FOR 3MM WIPE SIGNAL  
(4.2)  
FOR 2MM WIPE SIGNAL  
(6.4)  
FOR 4MM WIPE GROUND  
(5.4)  
FOR 3MM WIPE GROUND

Copyright FCI.

spec ref	-	dr	Mary Glass	2012/02/10	projection	MM	size	A2	scale	5:1
tolerance std	ISO 406 ISO 1101	eng	Sandar Soe	2013/03/20			ecn no	ELX-8-14229-1	rel level	Released
surface	ISO 1302	chr	-	appr						
linear	0.X ±0.3 0.XX ±0.10 0.XXX ±0.05	angular	0° ±2°			<b>TOLERANCES UNLESS OTHERWISE SPECIFIED</b>	<b>XCED HD VERTICAL HEADER</b> 3 PAIR, 4 COLUMN STITCH HEADER	10119126	rev <b>B</b>	
www.fci.com		cat. no.		Product - Customer Drw		sheet 7 of 8				

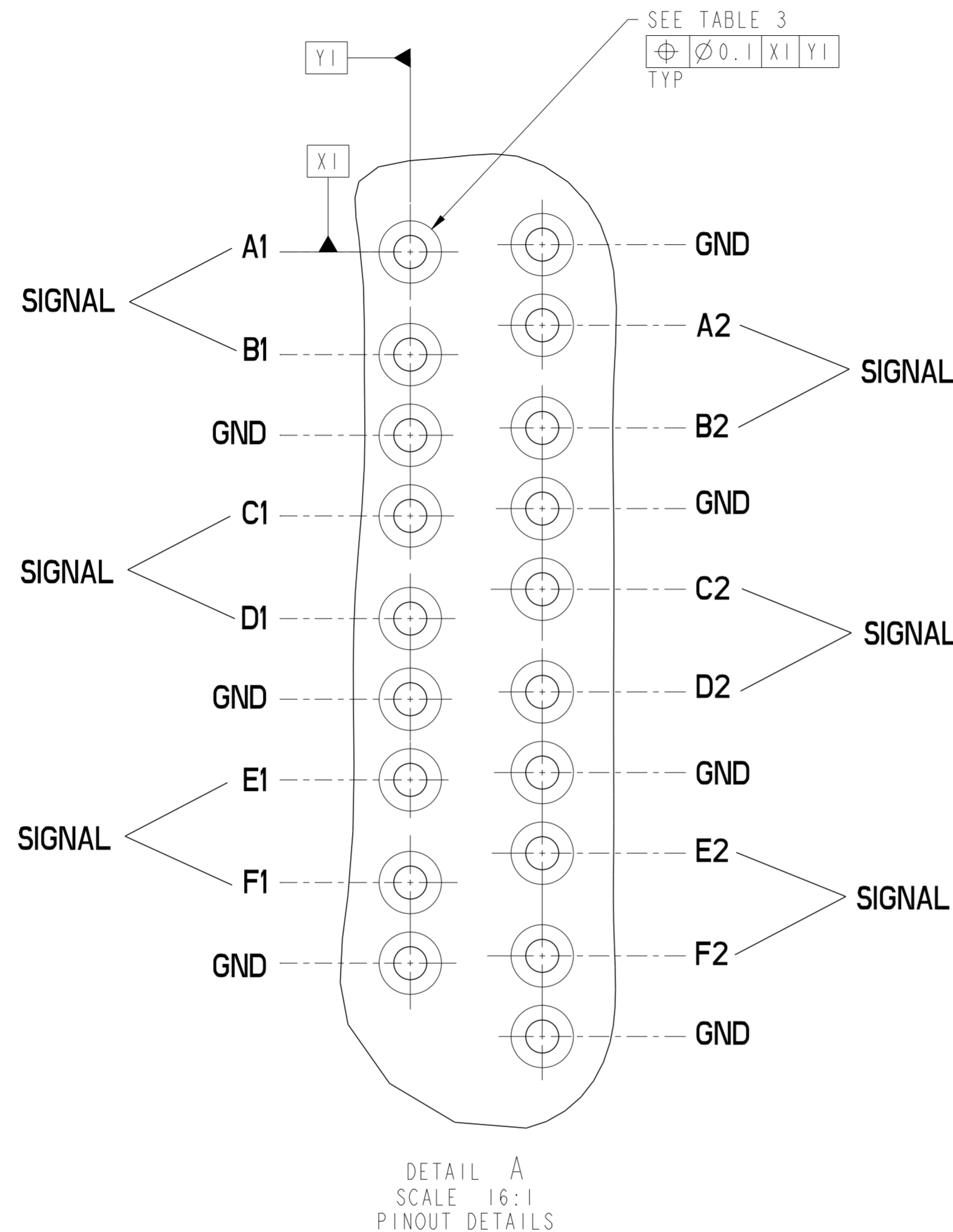

TABLE 3		
	COMPLIANT PIN DRILL $\varnothing 0.55$ [0.0217"]]	COMPLIANT PIN DRILL $\varnothing 0.45$ [0.0117"]]
PTH	$\varnothing 0.45 \pm 0.05$	$\varnothing 0.36 \pm 0.05$
DRILL	$\varnothing 0.55$ [0.0217"]]	$\varnothing 0.45$ [0.0117"]]
PAD	$\varnothing 0.85$	$\varnothing 0.75$

NOTES:

- CONNECTOR MATERIALS  
 SHROUD : HIGH-TEMP POLYMER, COLOR : BLACK, UL94V-0  
 CONTACTS : HIGH PERFORMANCE COPPER ALLOY
- PRODUCT SPECIFICATION : GS-12-0936
- APPLICATION SPECIFICATION : GS-20-0348
- PRODUCT MARKING :  
 PART NUMBER (10119126-X0J-XXXLF)  
 "FCI" AND DATE CODE (FCI P#####)
- NOTCH DESIGNATES "ROW A" SIDE OF CONNECTOR. NOTCH FEATURE ON OPPOSITE FOR PRODUCT MARKING.
- PLATING THICKNESS OF SIGNAL & GROUND CONTACT ARE DETERMINED BY PLATING CODE, REFER TO P/N TREE ON SHEET 1.
- PACKAGING MEETS GS-14-920 LEAD-FREE LABELING SPECIFICATION.
- GUIDE-PIN STYLE DESIGNATION ONLY APPLIES TO MODULE VERSIONS THAT REQUIRE GUIDE-PIN HARDWARE. FOR ALL NON-GUIDE-PIN VERSIONS, THE DEFAULT DASH-NUMBER DIGIT IN THAT LOCATION IS STILL '0'.
- SEE APPLICATION SPECIFICATION FOR ROUTING GUIDELINES, ADDITIONAL PTH GUIDELINES, MATED DIMENSIONS, GUIDE PIN SELECTION, ETC.
- A  $\triangle B$  SYMBOL WILL BE NEXT TO ANY DIMENSION, VIEW OR NOTE THAT HAS BEEN MODIFIED WITH THE CURRENT DRAWING REVISION.
- $\triangle B$  (11) OPTIONAL HOLE LOCATION FOR GROUNDED PIN OR ADDITIONAL GUIDE-PIN SUPPORT. SEE TABLE 1 SHEET 1 FOR ADDITIONAL DETAILS.
- $\triangle B$  (12) SCREW IS OPTIONAL AND ENGAGES WITH BOTTOM OF GUIDE PIN FROM BENEATH THE PCB FOR ADDITIONAL GUIDE-PIN SUPPORT.



Copyright FCI.

spec ref	-	dr	Mary Glass	2012/02/10	projection	MM	size	A2	scale	3:1	
tolerance std	ISO 406 ISO 1101	eng	Sandar Soe	2013/03/20			ecn no	ELX-8-14229-1	rel level	Released	
TOLERANCES UNLESS OTHERWISE SPECIFIED		chr	-	appr							Chen-Hong Tan
surface	ISO 1302	linear	0.X	$\pm 0.3$			product family	-	diag no	10119126	
			0.XX	$\pm 0.10$			title	XCEDE HD VERTICAL HEADER		rev	B
		angular	0°	$\pm 2^\circ$	cat. no.		Product - Customer Drw	sheet 8 of 8			