

RIGHT ANGLE PLUG SOLDER TYPE

R110.153.000

CABLE .085

Series : MMCX

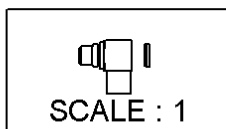
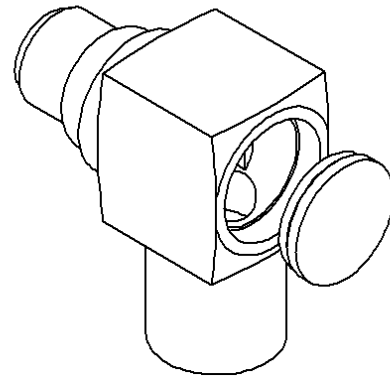
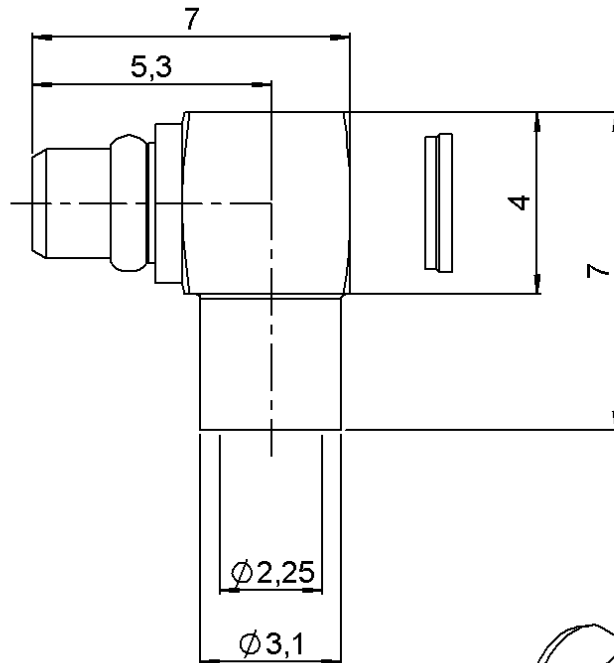

All dimensions are in mm.



COMPONENTS	MATERIALS	PLATING (µm)
BODY	BRASS	GOLD 0.2 OVER NICKEL 2
CENTER CONTACT	BRASS	GOLD 1.3 OVER NICKEL 2
OUTER CONTACT	-	-
INSULATOR	PTFE	-
GASKET	-	-
OTHERS PARTS	BERYLLIUM COPPER	GOLD 0.5 OVER NICKEL 2
-	-	-
-	-	-

Issue : 0645 D

In the effort to improve our products, we reserve the right to make changes judged to be necessary.



RIGHT ANGLE PLUG SOLDER TYPE

R110.153.000

CABLE .085

Series : MMCX

PACKAGING

Standard	Unit	Other
1	-	Contact us

SPECIFICATION

ELECTRICAL CHARACTERISTICS

Impedance	50	Ω
Frequency	0-6	GHz
VSWR	1.35 + 0,0000	x F(GHz) Maxi
Insertion loss	TBD	\sqrt{F} (GHz) dB Maxi
RF leakage	- (-)	- F(GHz)) dB Maxi
Voltage rating	250	Veff Maxi
Dielectric withstanding voltage	500	Veff mini
Insulation resistance	1000	M Ω mini

CABLE ASSEMBLY

Stripping	a	b	c	d	e	f
mm	2,60	2,00	0,00	0,00	0,00	0,00

Assembly instruction :

Recommended cable(s)
RG 405

Characteristics indicated on this data sheet are those that can be achieved with the highest performance cable. Intrinsic limitations of the cable may diminish the performance of the assembly

Cable retention

- pull off **155** N mini
- torque - N.cm

MECHANICAL CHARACTERISTICS

Center contact retention	
Axial force – Mating end	10 N mini
Axial force – Opposite end	10 N mini
Torque	NA N.cm mini

TOOLING

Part Number	Description	Hexagon
.	.	.
R282.740.020	SOLDERING MOUNTING	

Recommended torque	
Mating	NA N.cm
Panel nut	NA N.cm
Clamp nut	NA N.cm
A/F clamp nut	0,0000 mm

OTHER CHARACTERISTICS

Mating life	500	Cycles mini
Weight	0,5100	g

ENVIRONMENTAL

Operating temperature	-55/+155	$^{\circ}$ C
Hermetic seal	NA	Atm.cm3/s
Panel leakage	NA	

Issue : 0645 D

In the effort to improve our products, we reserve the right to make changes judged to be necessary.



RIGHT ANGLE PLUG SOLDER TYPE

R110.153.000

CABLE .085

Series : MMCX

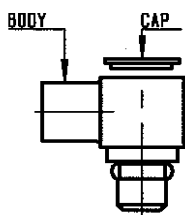

We recommend a thermal preconditioning cable

①

Strip the cable.
Clean the cable.
Tin cable inner conductor.

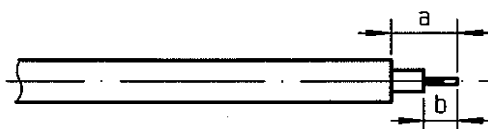

②

1 -Introduce the cable into the connector body until contact with the body shoulder, place the sub assembly into the assembly jig R282 740 020 and tighten it.
2 -Solder body on the cable and let assembly cool down before removing it from the jig.
3 -Clean soldering area.

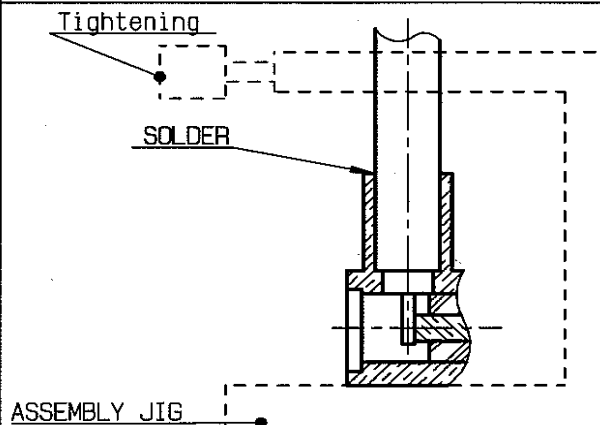

③

Solder cable inner conductor into the centre contact.
Clean soldering area.

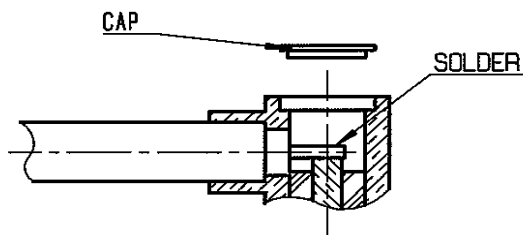

④

Put the cap in its place.
Press cap flush or slightly below surface of body assembly.

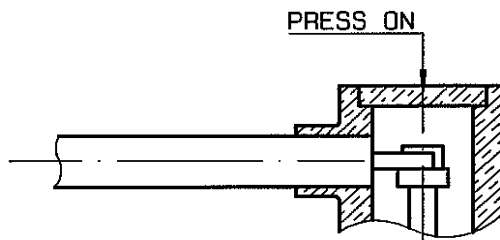

Issue : 0645 D

In the effort to improve our products, we reserve the right to make changes judged to be necessary.

