

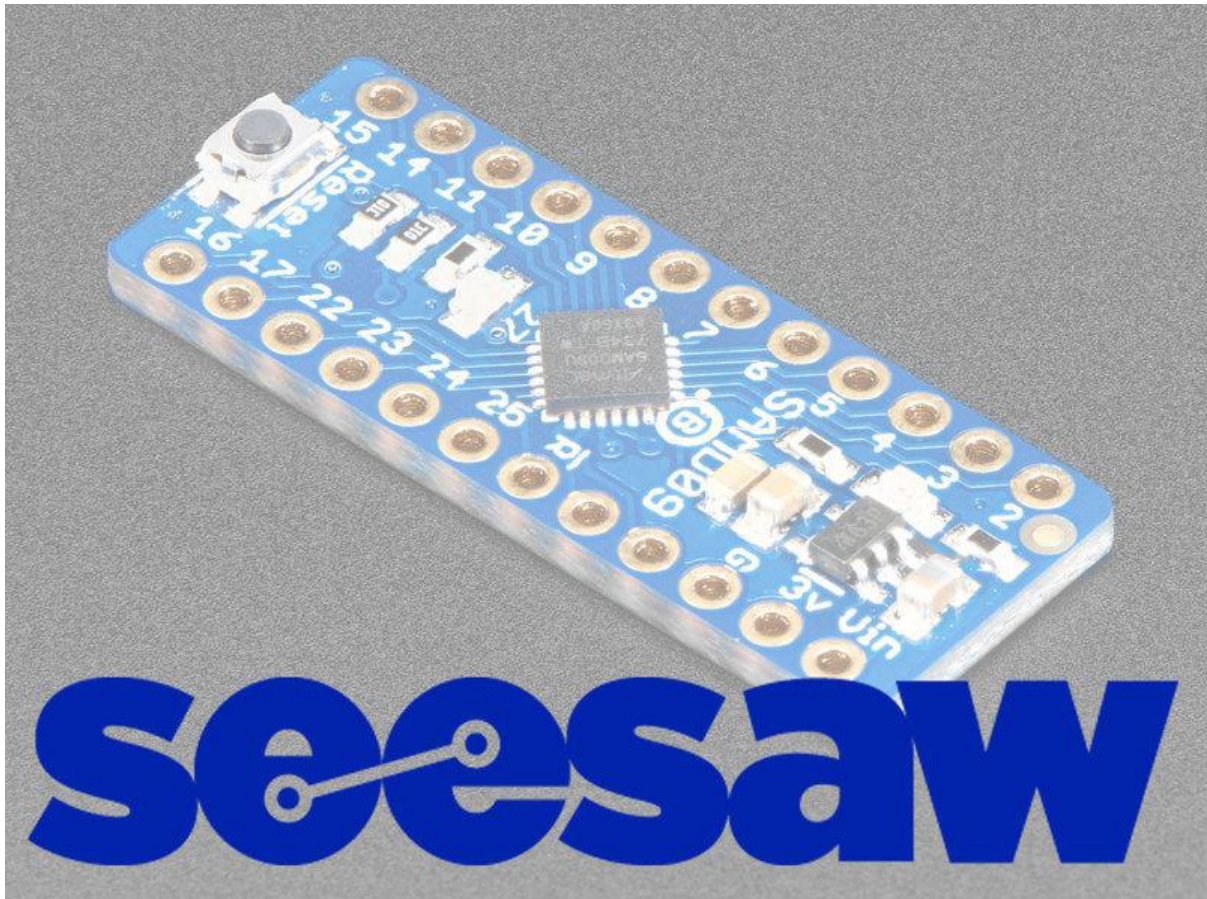

# Adafruit seesaw

Created by Dean Miller



<https://learn.adafruit.com/adafruit-seesaw-atsamd09-breakout>

Last updated on 2023-07-17 04:56:28 PM EDT

# Table of Contents

Overview	5
Pinouts	7
<ul style="list-style-type: none"><li>• Power Pins:</li><li>• Logic Pins:</li><li>• GPIO Pins:</li><li>• Neopixel Pins:</li><li>• Address Pins:</li><li>• ADC Pins:</li><li>• PWM Pins:</li><li>• Interrupt Pins:</li><li>• Programming Pins:</li></ul>	
Arduino Wiring & Test	9
<ul style="list-style-type: none"><li>• Arduino Wiring &amp; Test</li><li>• I2C Wiring</li><li>• Download Adafruit_Seasaw library</li><li>• Load Test Example</li><li>• Documentation</li></ul>	
CircuitPython Wiring & Test	12
<ul style="list-style-type: none"><li>• CircuitPython Wiring &amp; Test</li><li>• I2C Wiring</li><li>• Download Adafruit_CircuitPython_Seasaw library</li></ul>	
Python Docs	14
Raspberry Pi Wiring & Test	14
<ul style="list-style-type: none"><li>• Install Python Software</li><li>• Enable I2C</li><li>• Run example code</li><li>• Documentation</li><li>• Full Example Code</li></ul>	
Using the Seesaw Platform	19
Reading and Writing Data	19
<ul style="list-style-type: none"><li>• Setting the Device Address</li><li>• I2C Transactions</li><li>• Writing Data</li><li>• Reading Data</li></ul>	
Status	21
<ul style="list-style-type: none"><li>• Function Register Summary</li><li>• Function Register Description</li><li>• 0x01 - HW_ID</li><li>• 0x02 - VERSION</li><li>• 0x03 - OPTIONS</li><li>• 0x04 - TEMP</li><li>• 0x7F - SWRST</li></ul>	

- Function Registers
- GPIO register setup on SAMD09:
- GPIO register setup on ATtiny8x7:
- DIRSET (0x02, 32 bits, Write Only)
- DIRCLR (0x03, 32 bits, Write Only)
- GPIO (0x04, 32 bits, Read/Write)
- SET (0x05, 32 bits, Write Only)
- CLR (0x06, 32 bits, Write Only)
- TOGGLE (0x07, 32 bits, Write Only)
- INTENSET (0x08, 32 bits, Write Only)
- INTENCLR (0x09, 32 bits, Write Only)
- INTFLAG (0x0A, 32 bits, Read Only)
- PULLENSET (0x0B, 32 bits, Write Only)
- PULLENCLR (0x0C, 32 bits, Write Only)

---

## Analog to Digital Converter

28

- SAMD09 ADC channels are:
- ATtiny8x7 ADC channels are:
- Function Registers
- STATUS (0x00, 8bits, Read Only)
- 
- INTENSET (0x02, 8bits, Write Only)
- INTENCLR (0x03, 8bits, Write Only)
- WINMODE (0x04, 8bits, Write Only)
- WINTHRESH (0x05, 32bits, Write Only)
- CHANNEL\_0 (0x07, 16bits, Read Only)
- CHANNEL\_1 (0x08, 16bits, Read Only)
- CHANNEL\_2 (0x09, 16bits, Read Only)
- CHANNEL\_3 (0x0A, 16bits, Read Only)
- CHANNEL\_20 (0x1B, 16bits, Read Only)

---

## Interrupts

33

---

## NeoPixel

33

- Function Registers
- PIN (0x01, 8bits, Write Only)
- SPEED (0x02, 8bits, Write Only)
- BUF\_LENGTH (0x03, 16bits LE, Write Only)
- BUF (0x04, 32 bytes, Write Only)
- SHOW (0x05, no args, Write Only)

---

## EEPROM

35

- Function Registers
- SAMD09
- ATtiny817

---

## PWM

36

- Nomenclature
- Function Register Summary
- Function Register Description
- 0x01 - PWM\_VAL
- 0x02 - PWM\_FREQ
- Port Specific Details
- SAMD

- ATtiny

## UART

38

- 
- Function Registers
  - Status (0x00, 8bits, Read Only)
  - INTEN (0x02, 8bits, Read/Write)
  - INTENCLR (0x03, 8bits, Write Only)
  - BAUD (0x04, 32bits, Read/Write)
  - DATA (0x05, 32bytes, Read/Write )

## Downloads

41

- 
- Documents
  - Schematic
  - Dimensions

## Documentation

42

---

# Overview

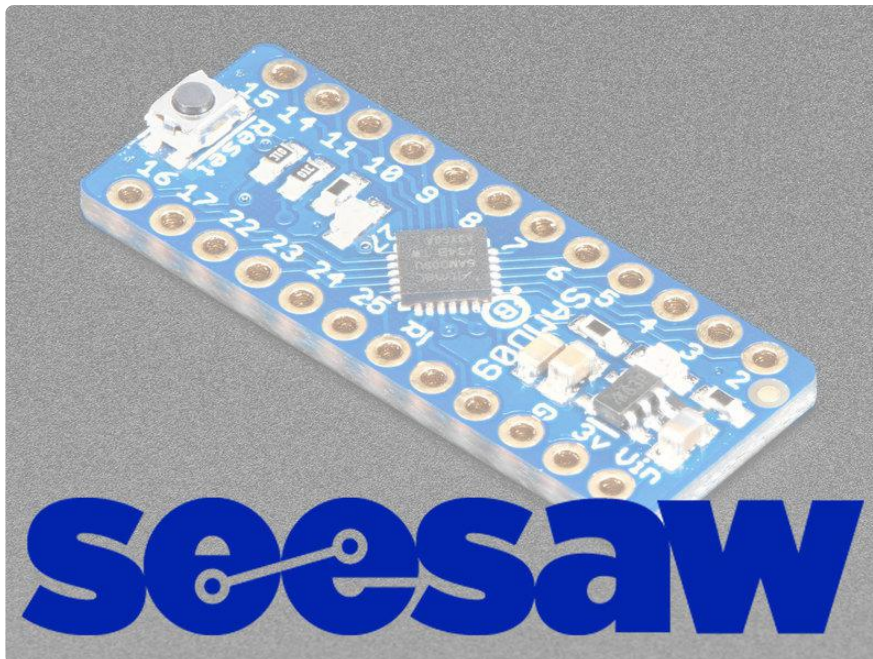

Adafruit seesaw is a near-universal converter framework which allows you to add and extend hardware support to any I2C-capable microcontroller or microcomputer. Instead of getting separate I2C GPIO expanders, ADCs, PWM drivers, etc, seesaw can be configured to give a wide range of capabilities.

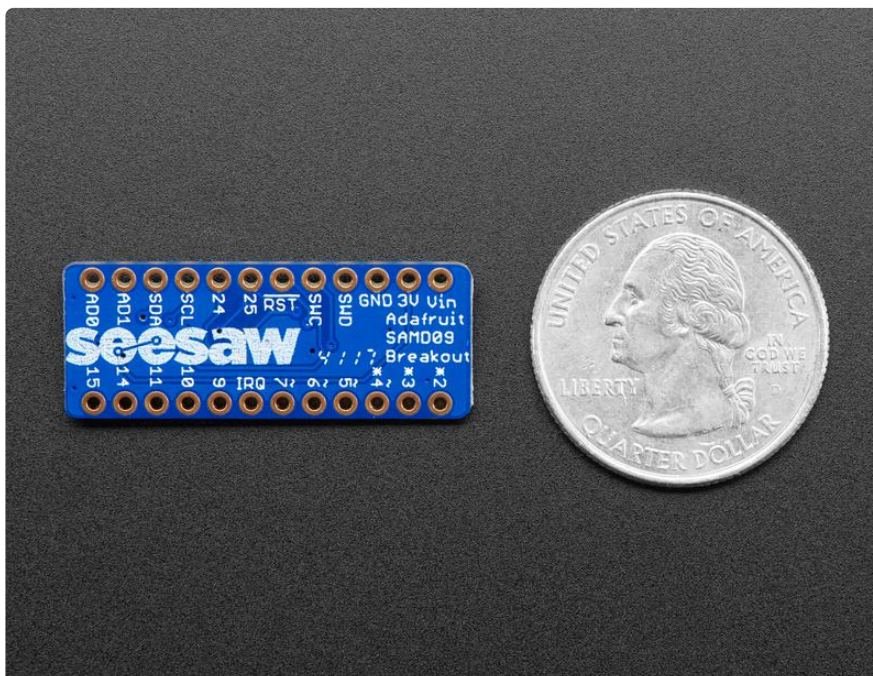

For example, our ATSAMD09 breakout with seesaw gives you

- 3 x 12-bit ADC inputs

- 3 x 8-bit PWM outputs
- 7 x GPIO with selectable pullup or pulldown
- 1 x NeoPixel output (up to 170 pixels)
- 1 x EEPROM with 64 byte of NVM memory (handy for storing small access tokens or MAC addresses)
- 1 x Interrupt output that can be triggered by any of the accessories
- 2 x I2C address selection pins
- 1 x Activity LED

But you can reprogram and reconfigure the chip to have more or less of each peripheral - as long as it fits into the ATSAM09D14's firmware! For example, there's also a UART converter but it isn't included in the default firmware.

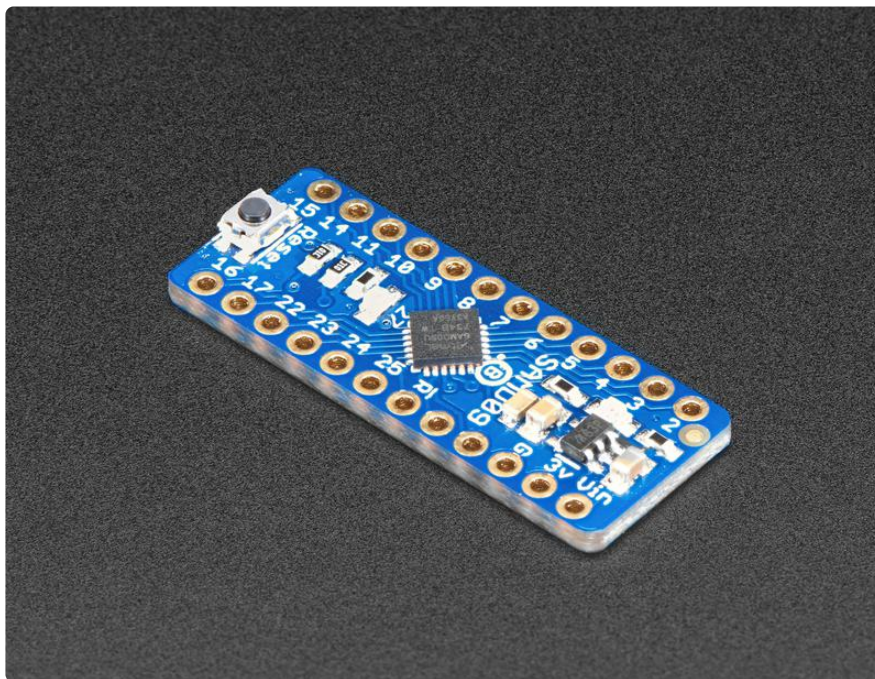

The ATSAM09 breakout is great for development of seesaw capabilities (we use it in-house for our design work) or you can use it as-is to give your Raspberry Pi or ESP8266 more hardware support! Each breakout comes with the assembled and tested board, as well as some header strips.

Please note: The boards do not come with a bootloader. If you want to do development using seesaw [you'll need to pick up a J-Link \(\)](#) and we recommend a [SW D adapter breakout \(\)](#) - at this time our project is for Atmel Studio but you could probably get it working with arm gcc and a Makefile. We don't provide any support for custom builds of seesaw - we think this is cool and useful for the Maker community!

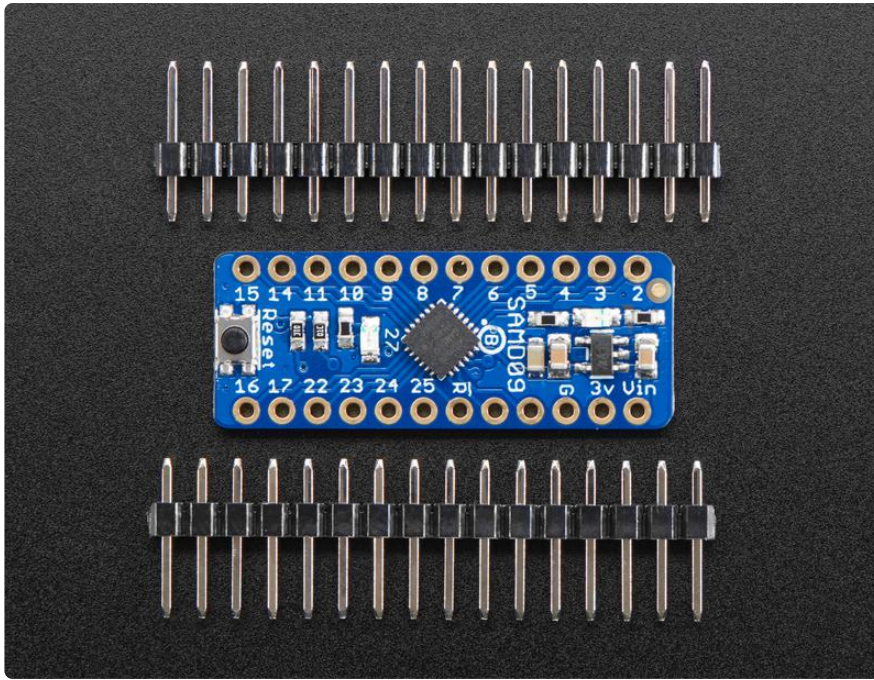

## Pinouts

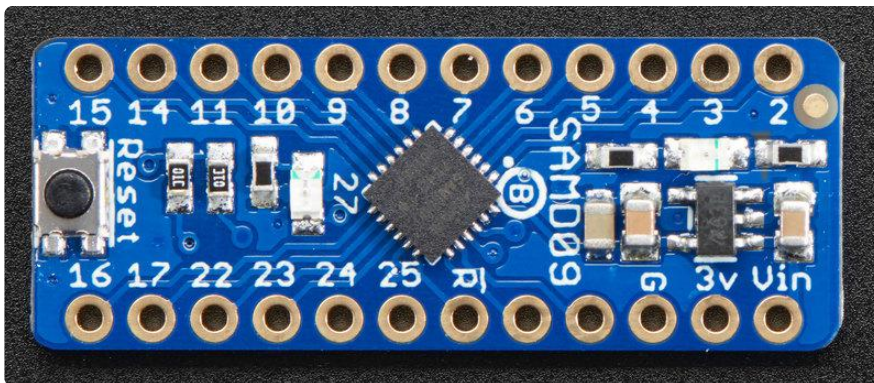

## Power Pins:

- Vin - this is the power pin. Since the ATSAM09 uses 3.3V, we have included an on-board voltage regulator that will take 3-5VDC and safely convert it down. You can power from 3.3V to 5V
- 3Vo - this is the 3.3V output from the voltage regulator, you can grab up to 100mA from this if you like
- GND - common ground for power and logic

## Logic Pins:

- 23 / SCL - this is the I2C clock pin, connect to your microcontrollers I2C clock line. There is a 10K pullup on this pin to 3.3V. I2C is 'open drain' which means as long as you don't add an extra pullup you can use with 5V logic devices.
- 22 / SDA - this is the I2C data pin, connect to your microcontrollers I2C data line. There is a 10K pullup on this pin to 3.3V. I2C is 'open drain' which means as long as you don't add an extra pullup you can use with 5V logic devices.
- RST - this is the reset pin. Pulling this pin to ground resets the device.

## GPIO Pins:

- Pins 9, 10, 11, 14, 15, 24, and 25 can be used as GPIO.

## Neopixel Pins:

- Pins 9, 10, 11, 14, 15, 24, and 25 can be used as the NeoPixel output.

## Address Pins:

- 16 / AD0 - this is the ADDR0 pin. Connect this to ground to increment the devices I2C address by 1.
- 17 / AD1 - this is the ADDR1 pin. Connect this to ground to increment the devices I2C address by 2.

## ADC Pins:

- 2 - this pin can be configured as an ADC input.
- 3 - this pin can be configured as an ADC input.



- 4 - this pin can be configured as an ADC input.

## PWM Pins:

- 5 - this pin can be configured as a PWM output.
- 6 - this pin can be configured as a PWM output.
- 7 - this pin can be configured as a PWM output.

## Interrupt Pins:

- 8 / IRQ - this pin gets pulled low by the seesaw to signal to your host microcontroller that an interrupt has occurred.

## Programming Pins:

- SWD - this pin connects to SWDIO of an SWD compatible programmer to program the device over SWD.
- SWC - this pin connects to SWCLK of an SWD compatible programmer to program the device over SWD.
- RST - this pin connects to RESET of an SWD compatible programmer to program the device over SWD.

---

# Arduino Wiring & Test

## Arduino Wiring & Test

You can easily wire this breakout to any microcontroller, we'll be using an Adafruit Metro M0 Express (Arduino compatible) with the Arduino IDE. But, you can use any other kind of microcontroller as well as long as it has I2C clock and I2C data lines.

## I2C Wiring

- Connect Vin to the power supply, 3-5V is fine.
- Connect GND to common power/data ground
- Connect the SCL pin (23) to the I2C clock SCL pin on your Microcontroller.
- Connect the SDA pin (22) to the I2C data SDA pin on your Microcontroller.

- Connect the positive (long lead) of an LED to pin 15 on the seesaw breakout and the other lead to GND through a 1k ohm resistor.

This seesaw uses I2C address 0x49 by default. You can change this by grounding the AD0/16 and/or AD1/15 pins, but we recommend not doing that until you have it working

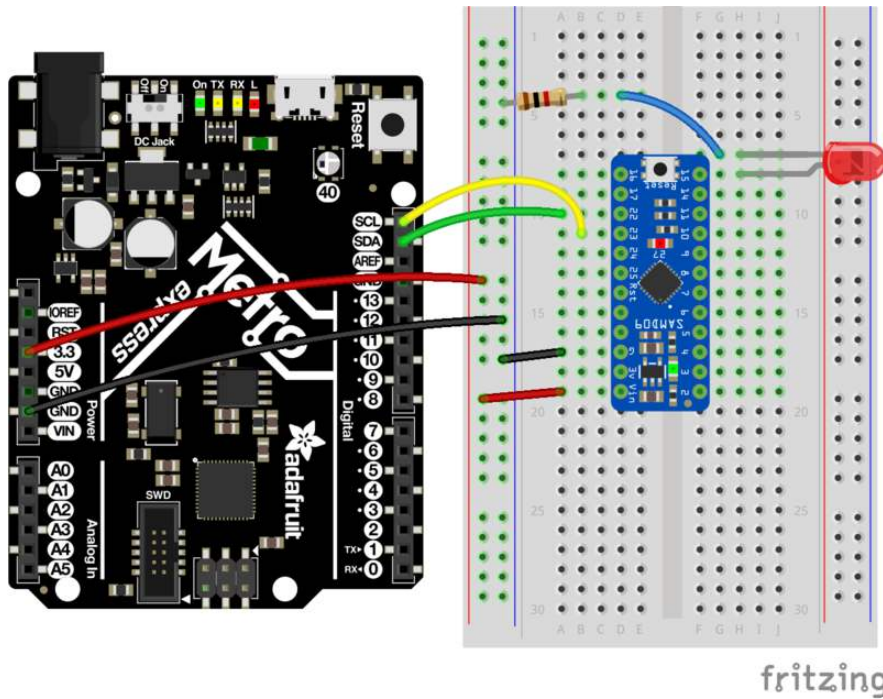

fritzing

## Download Adafruit\_Seesaw library

To begin reading sensor data, you will need to download Adafruit\_Seesaw from the Arduino library manager.

Open up the Arduino library manager:

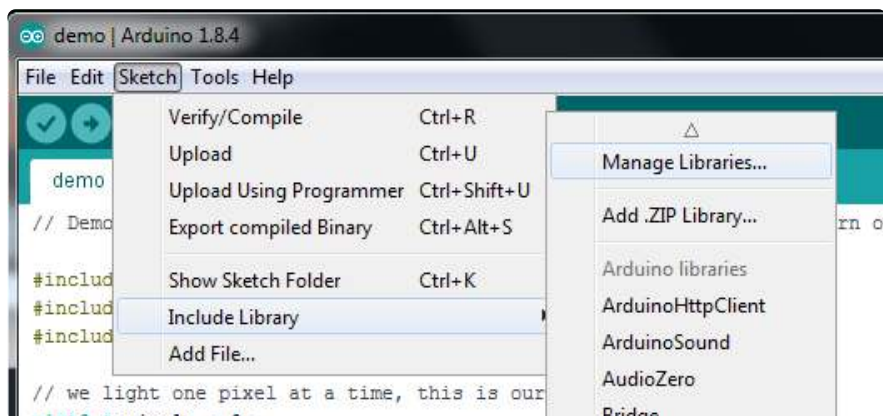

Search for the Adafruit Seesaw library and install it



We also have a great tutorial on Arduino library installation at:  
<http://learn.adafruit.com/adafruit-all-about-arduino-libraries-install-use> ()

## Load Test Example

Open up File->Examples->Adafruit\_Seesaw->digital->blink and upload to your Arduino wired up to the seesaw breakout. If everything is wired up correctly, the led should blink on and off repeatedly.

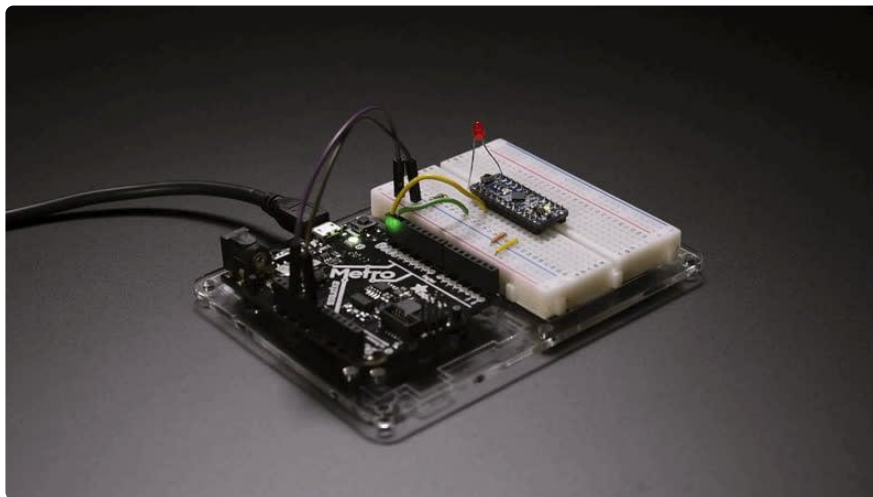
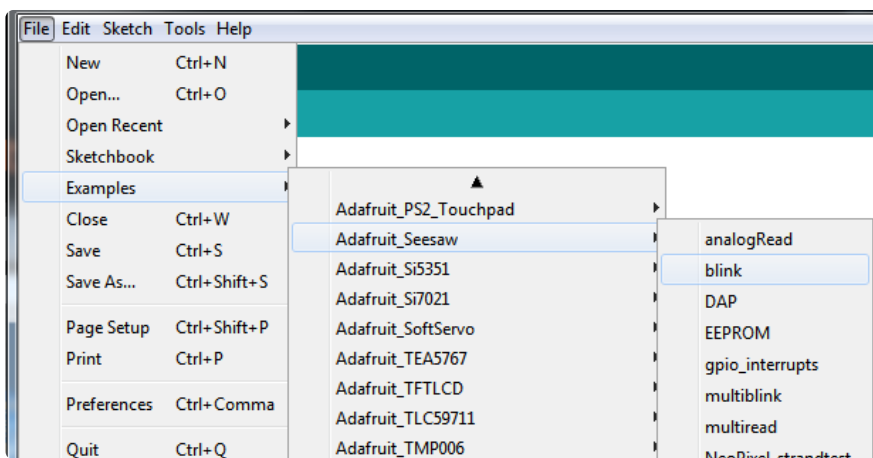

## Documentation

see [here](#) () for documentation of the seesaw python API.

---

# CircuitPython Wiring & Test

## CircuitPython Wiring & Test

You can easily wire this breakout to a microcontroller running CircuitPython. We will be using a Metro M0 Express.

### I2C Wiring

- Connect Vin to the power supply, 3-5V is fine.
- Connect GND to common power/data ground
- Connect the SCL pin (23) to the I2C clock SCL pin on your CircuitPython board, usually marked SCL. On a Gemma M0 this would be Pad #2/ A1
- Connect the SDA pin (22) to the I2C data SDA pin on your CircuitPython board, usually marked SDA. On an Gemma M0 this would be Pad #0/A2
- Connect the positive (long lead) of an LED to pin 15 on the samd09 breakout and the other lead to GND through a 1k ohm resistor.

The seesaw uses I2C address 0x49 by default. You can change this by grounding the AD0/16 and/or AD1/15 pins, but we recommend not doing that until you have it working

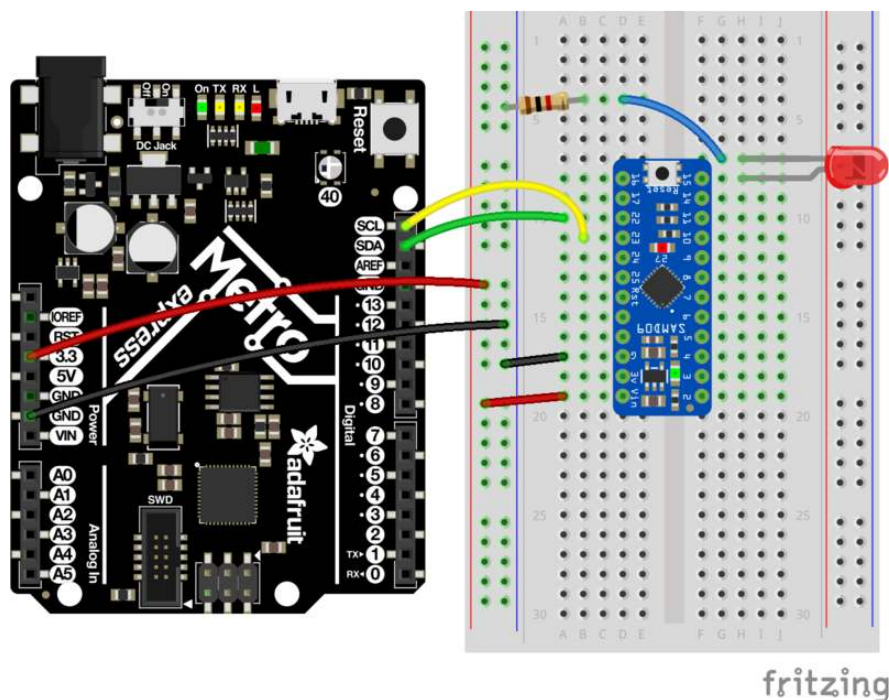

# Download Adafruit\_CircuitPython\_Seesaw library

To begin using the seesaw, you will need to download Adafruit\_CircuitPython\_Seesaw from our github repository. You can do that by visiting the github repo and manually downloading or, easier, just click this button to download the zip



Extract the zipped folder and rename the folder it contains to Adafruit\_seesaw. drag the Adafruit\_seesaw folder to the lib folder that appears on the CIRCUITPY drive. You'll also need the adafruit\_busdevice driver.

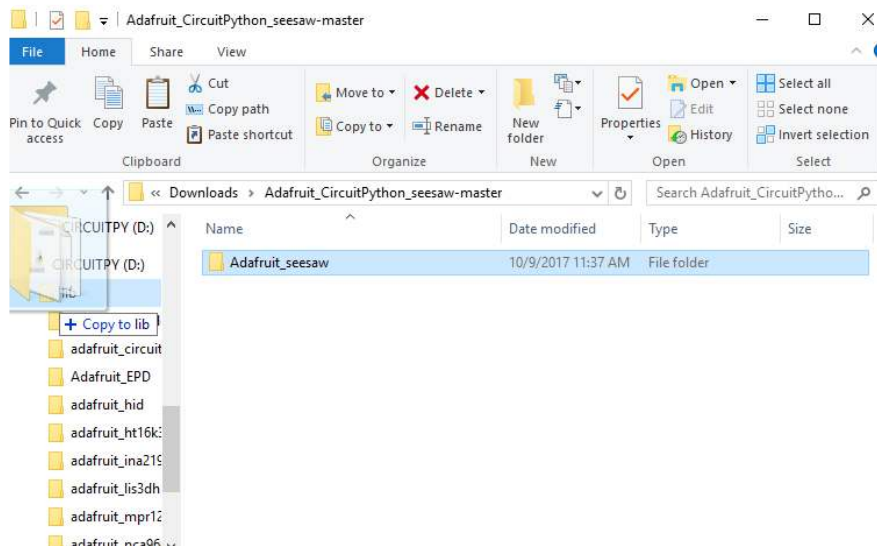

Our CircuitPython library may change APIs so consider this beta!

Open the code.py file on the CIRCUITPY drive and copy and paste the following code:

```
from board import *
import busio
from adafruit_seesaw.seesaw import Seesaw
import time

myI2C = busio.I2C(SCL, SDA)

ss = Seesaw(myI2C)

ss.pin_mode(15, ss.OUTPUT);

while True:
    ss.digital_write(15, True) # turn the LED on (True is the voltage level)
```

```
time.sleep(1)                # wait for a second
ss.digital_write(15, False) # turn the LED off by making the voltage LOW
time.sleep(1)
```

The LED attached to pin 15 should blink on and off repeatedly.

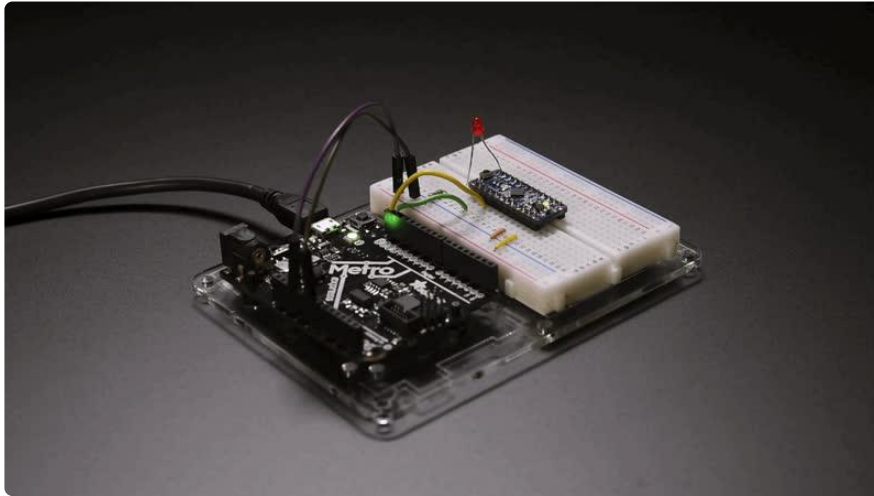

---

## Python Docs

[Python Docs \(\)](#)

---

## Raspberry Pi Wiring & Test

The Raspberry Pi also has an I2C interface that can be used to communicate with this seesaw. You can use this breakout with the CircuitPython library and Python [thanks to Adafruit\\_Blinka, our CircuitPython-for-Python compatibility library \(\)](#).

## Install Python Software

You'll need to install the Adafruit\_Blinka library that provides the CircuitPython library support in Python. This may also require enabling I2C on your platform and verifying you are running Python 3.

Once that's done, from your command line run the following command:

- `sudo pip3 install adafruit-circuitpython-seesaw`

If your default Python is version 3 you may need to run '`pip`' instead. Just make sure you aren't trying to use CircuitPython on Python 2.x, it isn't supported!

# Enable I2C

We need to enable the I2C bus so we can communicate with the seesaw.

```
sudo raspi-config
```

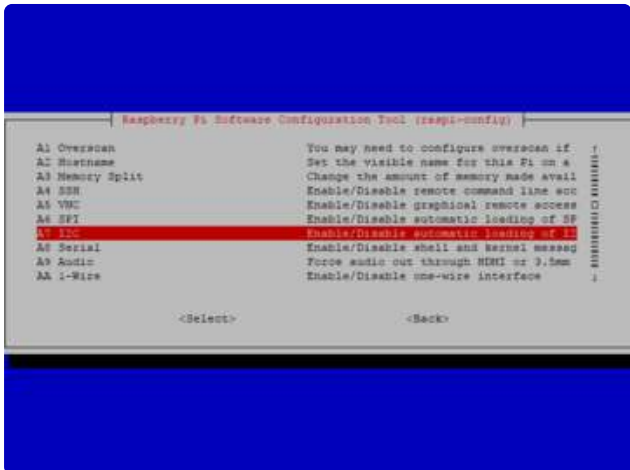
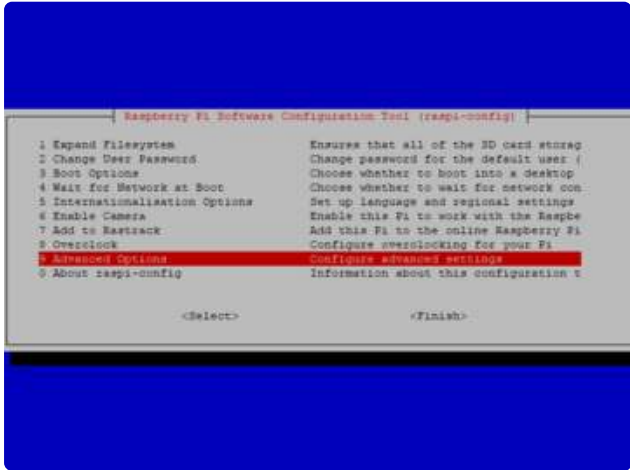

select Advanced options, enable I2C, and then finish.



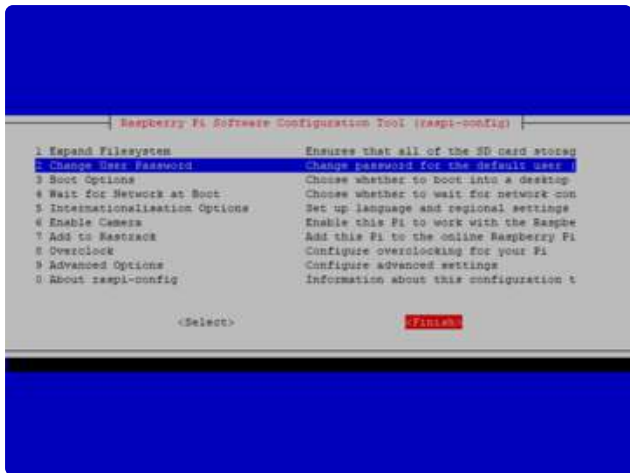

With the Pi powered off, we can wire up the sensor to the Pi Cobbler like this:

- Connect Vin to the 3V or 5V power supply (either is fine)
- Connect GND to the ground pin on the Cobbler
- Connect SDA (22) to SDA on the Cobbler
- Connect SCL (23) to SCL on the Cobbler
- Connect the positive (long lead) of an LED to pin 15 on the samd09 breakout and the other lead to GND through a 1k ohm resistor.

You can also use direct wires, we happen to have a Cobbler ready. remember you can plug the cobbler into the bottom of the PiTFT to get access to all the pins!

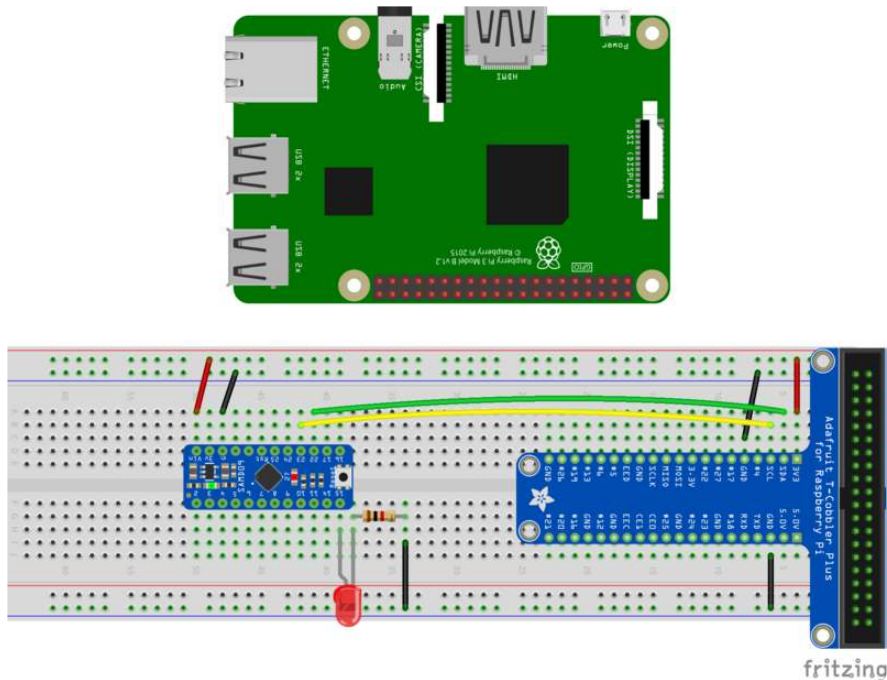

Now you should be able to verify that the sensor is wired up correctly by asking the Pi to detect files what addresses it can see on the I2C bus:



```
sudo i2cdetect -y 1
```

It should show up under it's default address (0x49). If you don't see 49, check your wiring, did you install I2C support, etc?

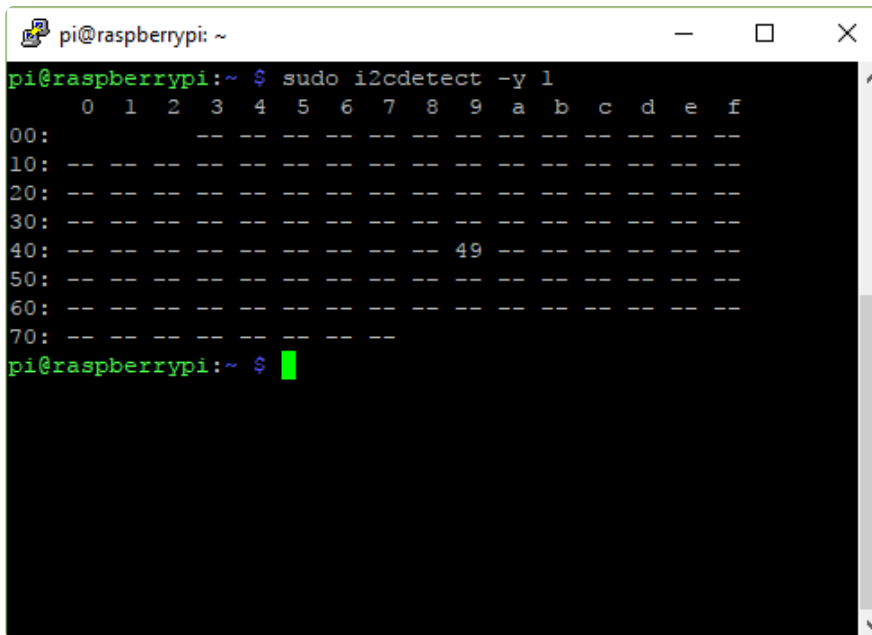

```
pi@raspberrypi: ~  
pi@raspberrypi:~ $ sudo i2cdetect -y 1  
 0  1  2  3  4  5  6  7  8  9  a  b  c  d  e  f  
00: -- -- -- -- -- -- -- -- -- -- -- -- -- -- --  
10: -- -- -- -- -- -- -- -- -- -- -- -- -- -- --  
20: -- -- -- -- -- -- -- -- -- -- -- -- -- -- --  
30: -- -- -- -- -- -- -- -- -- -- -- -- -- -- --  
40: -- -- -- -- -- -- 49 -- -- -- -- -- -- -- --  
50: -- -- -- -- -- -- -- -- -- -- -- -- -- -- --  
60: -- -- -- -- -- -- -- -- -- -- -- -- -- -- --  
70: -- -- -- -- -- -- -- -- -- -- -- -- -- -- --  
pi@raspberrypi:~ $ █
```

## Run example code

At long last, we are finally ready to run our example code. Open the Python REPL to begin.

First we'll import the necessary libraries, initialise the I2C bus and setup the LED pin for use:

```
import time  
import board  
import busio  
from adafruit_seesaw.seesaw import Seesaw  
  
i2c_bus = busio.I2C(board.SCL, board.SDA)  
ss = Seesaw(i2c_bus)  
  
ss.pin_mode(15, ss.OUTPUT)
```

Now you're ready to blink the LED using `digital_write`:

```
while True:  
    ss.digital_write(15, True)  
    time.sleep(1)  
    ss.digital_write(15, False)  
    time.sleep(1)
```

If everything is set up correctly, the LED attached to pin 15 on the SAMD09 breakout should blink on and off repeatedly. Press CTRL + C to stop the program running once you are satisfied with the blinking.

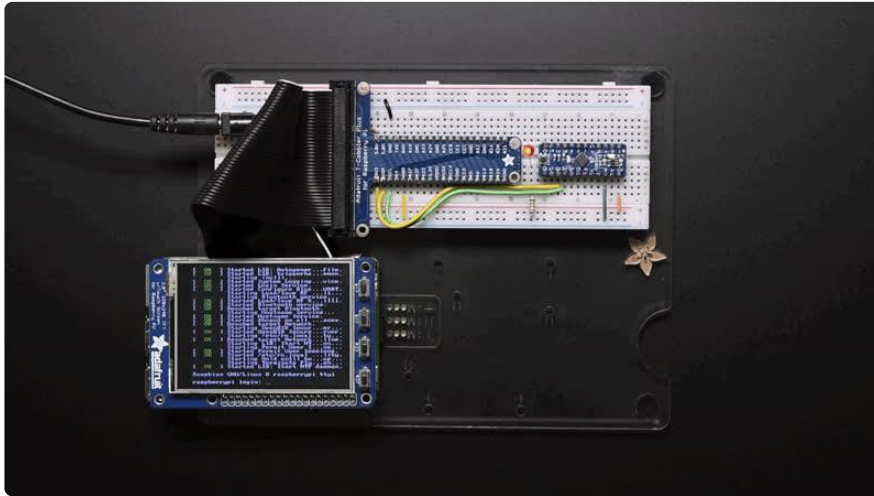

## Documentation

See [here \(\)](#) for documentation of the seesaw CircuitPython API.

## Full Example Code

```
# SPDX-FileCopyrightText: 2021 ladyada for Adafruit Industries
# SPDX-License-Identifier: MIT

# Simple seesaw test using an LED attached to Pin 15.
#
# See the seesaw Learn Guide for wiring details:
# https://learn.adafruit.com/adafruit-seesaw-atsamd09-breakout?
view=all#circuitpython-wiring-and-test
import time

import board
from adafruit_seesaw.seesaw import Seesaw

i2c_bus = board.I2C() # uses board.SCL and board.SDA
# i2c_bus = board.STEMMA_I2C() # For using the built-in STEMMA QT connector on a
microcontroller

ss = Seesaw(i2c_bus)

ss.pin_mode(15, ss.OUTPUT)

while True:
    ss.digital_write(15, True) # turn the LED on (True is the voltage level)
    time.sleep(1) # wait for a second
    ss.digital_write(15, False) # turn the LED off by making the voltage LOW
    time.sleep(1)
```

---

# Using the Seesaw Platform



The sections under this heading contain more detailed information about how the Seesaw platform works. If you are using our Arduino, CircuitPython, or Python API you can skip these sections. These sections are intended for people who either want to understand and modify seesaw, or who want to make their own API for a platform that is not officially supported by Adafruit such as C/C++ on Raspberry Pi.

---

## Reading and Writing Data

The SeeSaw operates as an I2C secondary device using standard I2C protocol. It uses the SDA and SCL pins to communicate with the host system.

The I2C bus on the SAMD09 is 3.3V logic level, but all boards other than the SAMD09 breakout have level shifting so you can use 3 or 5V logic. Boards with Attiny chips are 3 or 5V safe so you can use either for power and logic

Only 7-bit addressing is supported.

I2C pullup resistors are included in our SeeSaw boards but if you are DIY'ing, be sure to add your own! 2.2K - 10K is a good range.

## Setting the Device Address

Standard 7-bit addressing is used. The seesaw's default I2C address is initially configured in the compiled firmware (e.g for theSeeSaw breakouts we use 0x49) but other boards will have a different base address. Check the board documentation for the default base I2C address, [or you can plug it in and scan the I2C bus to find it \(\)](#).

This address can be modified using the address select pins, there can be multiple address pins. If address select pin 0 (A0) is tied to ground on boot, the I2C address is incremented by 1. If address select pin 1 (A1) is pulled low, the I2C address is incremented by 2. If both address select pins are pulled low, the I2C address is incremented by 3. Thus you can, with the same hardware, have up to 4 devices

On both the SAMD09 and Attiny817 breakouts, the default A0 pin is 16, default A1 pin is 17. On boards where the chips are embedded, there may be as many as 4 address pins, they'll be labeled with jumpers

The base I2C address can also be modified by writing a new address to EEPROM. See the EEPROM section for more information.

## I2C Transactions

We recommend using 100KHz I2C, but speeds of up to 400KHz are supported. You may want to decrease the SDA/SCL pullups to 2.2K from 10K in that case.

### Writing Data

A seesaw write command consists of the standard I2C write header (with the R/W bit set to 0), followed by 2 register bytes followed by zero or more data bytes.

The first register byte is the module base register address. Each module (GPIO, ADC, DAC, etc.) has it's own unique 8 bit base identifier.

The second register byte is the module function register address. This byte specifies the desired register within the module to be written.

Thus we have up to 254 modules available (0x00 is reserved) and 255 functions per module - plenty to allow all sorts of different capabilities!

In code, this may look like this (using the Arduino wire I2C object):

```
void Adafruit_seesaw::write(uint8_t moduleBase, uint8_t moduleFunction, uint8_t
*buf, uint8_t num)
{
    Wire.beginTransaction((uint8_t)_i2caddr);
    Wire.write((uint8_t)moduleBase); //module base register address
    Wire.write((uint8_t)moduleFunction); //module function register address
    Wire.write((uint8_t *)buf, num); //data bytes
    Wire.endTransmission();
}
```

The Arduino UNO Wire library implementation has a limit of 32 bytes per transaction so be aware you may not be able to read/write more than that amount. We have designed the library to work within those constraints

## Reading Data

A register read is accomplished by first sending the standard I2C write header, followed by the two register bytes corresponding to the data to be read. Allow a short delay, and then send a standard I2C read header (with the R/W bit set to 1) to read the data.

The length of the required delay depends on the data that is to be read. These delays are discussed in the sections specific to each module.

In code, this may look like this (using the Arduino wire I2C object):

```
void Adafruit_seesaw::read(uint8_t moduleBase, uint8_t moduleFunction, uint8_t
*buf, uint8_t num, uint16_t delay)
{
  Wire.beginTransmission((uint8_t)_i2caddr);
  Wire.write((uint8_t)moduleBase); //module base register address
  Wire.write((uint8_t)moduleFunction); //module function register address
  Wire.endTransmission();

  delayMicroseconds(delay);

  Wire.requestFrom((uint8_t)_i2caddr, num);

  for(int i=0; i<num; i++){
    buf[i] = Wire.read();
  }
}
```

---

## Status

0x00

Base Register Address

This module provides hardware specific information, status, and soft reset.

## Function Register Summary

Register Address	Register Name	Register Size	Access
0x01	HW_ID	1 byte	R

0x02	VERSION	4 bytes	R
0x03	OPTIONS	4 bytes	R
0x04	TEMP	4 bytes	R
0x7F	SWRST	0 bytes	W

## Function Register Description

### 0x01 - HW\_ID

Byte 0
Hardware ID Code

A single byte value that provides the hardware specific Hardware ID Code.

### 0x02 - VERSION

Byte 0	Byte 1	Byte 2	Byte 3
Product Code MSB	Product Code LSB	Date Code MSB	Date Code LSB

The Product Code is a unique 16 bit number assigned to each product.

The Date Code is a 16 bit value that indicates the year, month, and day of the firmware build:

- Top 5 bits are day of the month (1-31)

- Middle 4 bits are month (1-12)
- Bottom 7 bits are 20xx year (00-99)

Here's a Python function for decoding a Date Code into year, month, and day:

```
def datecode_decode(code):
    year = code & 0x7F // bottom 7 bits are 20xx year (00-99)
    month = (code >> 7) & 0x0F // middle 4 bits are month (1-12)
    day = (code >> 11) & 0x1F // top 5 bits are day of month (1-31)
    return year, month, day
```

## 0x03 - OPTIONS

Byte 0	Byte 1	Byte 2	Byte 3
Options MSB	Options	Options	Options LSB

Options is a 32 bit field register indicating if a specific option (ADC, PWM, etc.) has been enabled or not within the firmware. If enabled, the bit reads a 1, otherwise 0.

Bit locations for options are defined below:

```
#define SEESAW_STATUS_BASE 0x00
#define SEESAW_GPIO_BASE 0x01
#define SEESAW_SERCOM0_BASE 0x02
#define SEESAW_SERCOM1_BASE 0x03
#define SEESAW_SERCOM2_BASE 0x04
#define SEESAW_SERCOM3_BASE 0x05
#define SEESAW_SERCOM4_BASE 0x06
#define SEESAW_SERCOM5_BASE 0x07
#define SEESAW_TIMER_BASE 0x08
#define SEESAW_ADC_BASE 0x09
#define SEESAW_DAC_BASE 0x0A
#define SEESAW_INTERRUPT_BASE 0x0B
#define SEESAW_DAP_BASE 0x0C
#define SEESAW_EEPROM_BASE 0x0D
#define SEESAW_NEOPixel_BASE 0x0E
#define SEESAW_TOUCH_BASE 0x0F
#define SEESAW_KEYPAD_BASE 0x10
#define SEESAW_ENCODER_BASE 0x11
```

## 0x04 - TEMP

Byte 0	Byte 1	Byte 2	Byte 3
--------	--------	--------	--------

Temperature MSB	Temperature	Temperature	Temperature LSB
-----------------	-------------	-------------	-----------------

The on board Temperature of the device, as a signed 32 bit integer.

## 0x7F - SWRST

Writing to the register address will initiate a software reset.

# GPIO

The GPIO module provides every day input and outputs. You'll get logic GPIO pins that can act as outputs or inputs. With pullups or pulldowns. When inputs, you can also create pin-change interrupts that are routed the the IRQ pin.

On SAMD09-based boards the GPIO is 3V only. On ATtiny-based boards, the GPIO logic is whatever the power pin is, 3V or 5V.

The module base register address for the GPIO module is 0x01.

## Function Registers

Register Address	Function Name	Register Size	Notes
0x02	DIRSET	32 bits	Write Only
0x03	DIRCLR	32 bits	Write Only
0x04	GPIO	32 bits	Read/Write
0x05	SET	32 bits	Write Only



0x06	CLR	32 bits	Write Only
0x07	TOGGLE	32 bits	Write Only
0x08	INTENSET	32 bits	Write Only
0x09	INTENCLR	32 bits	Write Only
0x0A	INTFLAG	32 bits	Read Only
0x0B	PULLENSET	32 bits	Write Only
0x0C	PULLENCLR	32 bits	Write Only

Writes of GPIO function registers should contain 4 data bytes (32 bits) following the initial register data bytes. Each bit in these registers represents a GPIO pin on PORTA of the seesaw device.

If the corresponding pin does not exist on the SeeSaw device, then reading or writing the bit has no effect.

We decided to go with this method to make GPIO toggling fast (rather than having one i2c transaction per individual pin control) but the host processor will need to do a little work to keep the pins identified.

## GPIO register setup on SAMD09:

Bit 31	Bit 30	Bit 29	Bit 28	Bit 27	...	Bit 4	Bit 3	Bit 2	Bit 1	Bit 0
PA31	PA30	PA29	PA28	PA27	...	PA04	PA03	PA02	PA01	PA00

## GPIO register setup on ATTiny8x7:

[\(this is the same as the megaTinyCore pin mapping \(\)\)](#)

- Bit 0: PA4
- Bit 1: PA5
- Bit 2: PA6
- Bit 3: PA7
- Bit 4: PB7
- Bit 5: PB6
- Bit 6: PB5
- Bit 7: PB4
- Bit 8: PB3
- Bit 9: PB2
- Bit 10: PB1
- Bit 11: PB0
- Bit 12: PC0
- Bit 13: PC1
- Bit 14: PC2
- Bit 15: PC3
- Bit 16: PC4
- Bit 17: PC5
- Bit 18: PA1
- Bit 19: PA2
- Bit 20: PA3

## DIRSET (0x02, 32 bits, Write Only)

Writing a 1 to any bit in this register sets the direction of the corresponding pin to OUTPUT.

Writing zeros to this register has no effect.

## DIRCLR (0x03, 32 bits, Write Only)

Writing a 1 to any bit in this register sets the direction of the corresponding pin to INPUT.

Writing zeros to this register has no effect.

## GPIO (0x04, 32 bits, Read/Write)

When this register is written, all bits that are set to 0 will have their corresponding pins set LOW.

All bits that are set to 1 will have their corresponding pins set HIGH.

Reading this register reads all pins on of the seesaw device. On the Attiny series please wait at least 250uS between command write and data read to allow the data to be read and formatted for retrieval. Reading this register will also reset the IRQ pin if it was configured.

## SET (0x05, 32 bits, Write Only)

Writing a 1 to any bit in this register writes the corresponding pin HIGH.

Writing zeros to this register has no effect.

## CLR (0x06, 32 bits, Write Only)

Writing a 1 to any bit in this register writes the corresponding pin LOW.

Writing zeros to this register has no effect.

## TOGGLE (0x07, 32 bits, Write Only)

Writing a 1 to any bit in this register toggles the corresponding pin.

Writing zeros to this register has no effect.

## INTENSET (0x08, 32 bits, Write Only)

Writing a 1 to any bit in this register enables the interrupt on the corresponding pin. When the value on this pin changes, the corresponding bit will be set in the INTFLAG register.

Writing zeros to this register has no effect.

## INTENCLR (0x09, 32 bits, Write Only)

Writing a 1 to any bit in this register disables the interrupt on the corresponding pin.

Writing zeros to this register has no effect.

## INTFLAG (0x0A, 32 bits, Read Only)

This register hold the status of all GPIO interrupts. When an interrupt fires, the corresponding bit in this register gets set. Reading this register clears all interrupts. This will also reset the IRQ pin if it was configured.

Writing to this register has no effect.

## PULLENSET (0x0B, 32 bits, Write Only)

Writing a 1 to any bit in this register enables the internal pullup or pulldown on the corresponding pin. The pull direction (up/down) is determined by the GPIO (output) value - if the corresponding GPIO register bit is low, its a pulldown. High, its a pullup.

Writing zeros to this register has no effect.

## PULLENCLR (0x0C, 32 bits, Write Only)

Writing a 1 to any bit in this register disables the pull up/down on the corresponding pin.

Writing zeros to this register has no effect.

---

## Analog to Digital Converter

The ADC provides the ability to measure analog voltages at 10-bit resolution. The SAMD09 seesaw has 4 ADC inputs, the Attiny8x7 has 11 ADC inputs.

The module base register address for the ADC is 0x09

Conversions can be read by reading the corresponding CHANNEL register.

When reading ADC data, there should be at least a 500 uS delay between writing the register number you would like to read from and attempting to read the data.

Allow a delay of at least 1ms in between sequential ADC reads on different channels.

## SAMD09 ADC channels are:

Channel 0	PA02
Channel 1	PA03
Channel 2	PA04
Channel 3	PA05

## ATtiny8x7 ADC channels are:

- Channel 0: PA4
- Channel 1: PA5
- Channel 2: PA6
- Channel 3: PA7
- Channel 6: PB5
- Channel 7: PB4
- Channel 10: PB1
- Channel 11: PB0
- Channel 18: PA1
- Channel 19: PA2
- Channel 20: PA3

[\(These are the same as the Arduino GPIO pin names for the ADCs in megaTinyCore \(\)\)](#)

# Function Registers

Register Address	Register Name	Register Size	Notes
0x00	STATUS	8 bits	Read Only
0x02	INTENSET	8 bits	Write Only
0x03	INTENCLR	8 bits	Write Only
0x04	WINMODE		Write Only
0x05	WINTHRESH	32 bits	Write Only
0x07	CHANNEL_0	16 bits	Read Only
0x08	CHANNEL_1	16 bits	Read Only
0x09	CHANNEL_2	16 bits	Read Only
0x0A	CHANNEL_3	16 bits	Read Only
...	...	...	...
0x1B	CHANNEL_20	16-bit	Read Only

Window mode or ADC interrupts is not yet supported as of the time of writing this guide.

## STATUS (0x00, 8bits, Read Only)

This register contains status information on the ADC

Bit 7	Bit 6	Bit 5	Bit 4	Bit 3	Bit 2	Bit 1	Bit 0
Reserved	Reserved	Reserved	Reserved	Reserved	Reserved	WINMON_INT	ERROR

## INTENSET (0x02, 8bits, Write Only)

Writing a 1 to any bit in this register enables the corresponding interrupt.

Writing zeros to this register has no effect.

Bit 7	Bit 6	Bit 5	Bit 4	Bit 3	Bit 2	Bit 1	Bit 0
Reserved	Reserved	Reserved	Reserved	Reserved	Reserved	Reserved	WINMON

## INTENCLR (0x03, 8bits, Write Only)

Writing a 1 to any bit in this register enables the corresponding interrupt.

Writing zeros to this register has no effect.

## WINMODE (0x04, 8bits, Write Only)

Writing 1 to this register sets window control.

## WINTHRESH (0x05, 32bits, Write Only)

This register sets the threshold values for window mode.

Bits 31 - 16	Bits 15 - 0
High Threshold	Low Threshold

## CHANNEL\_0 (0x07, 16bits, Read Only)

ADC value for channel 0

## CHANNEL\_1 (0x08, 16bits, Read Only)

ADC value for channel 1

## CHANNEL\_2 (0x09, 16bits, Read Only)

ADC value for channel 2

## CHANNEL\_3 (0x0A, 16bits, Read Only)

ADC value for channel 3

...

## CHANNEL\_20 (0x1B, 16bits, Read Only)

ADC value for channel 20



---

# Interrupts

The seesaw has a configurable interrupt pin that can be triggered through various channels.

Once the interrupt is triggered, it can be only be cleared when the conditions of it's source module(s) have been met (e.g. data has been read, an interrupt has been cleared by reading an INTFLAG register).

See individual module sections for details on their available interrupt configurations.

The hardware interrupt pin is available on PA08 (#8)

---

# NeoPixel

The seesaw has built in NeoPixel support for up to 170 RGB or 127 RGBW pixels. The output pin as well as the communication protocol frequency are configurable. Note: older firmware is limited to 63 pixels max.

The module base register address for the NeoPixel module is 0x0E.

# Function Registers

Register Address	Register Name	Register Size	Notes
0x01	PIN	8 bits	Write Only
0x02	SPEED	8 bits	Write Only
0x03	BUF_LENGTH	16 bits	Write Only
0x04	BUF	32 bytes	Write Only

0x05	SHOW	none	Write Only
------	------	------	------------

## PIN (0x01, 8bits, Write Only)

This register sets the pin number (PORTA) that is used for the NeoPixel output.

## SPEED (0x02, 8bits, Write Only)

The protocol speed.

0x00 = 400khz

0x01 = 800khz (default)

## BUF\_LENGTH (0x03, 16bits LE, Write Only)

the number of bytes currently used for the pixel array. This is dependent on when the pixels you are using are RGB or RGBW. 2 Bytes, little endian order

## BUF (0x04, 32 bytes, Write Only)

The data buffer. The first 2 bytes are the start address, and the data to write follows. Data should be written in blocks of maximum size 30 bytes at a time.

Bytes 0 - 1	Bytes 2 - 32
Start address	Data

## SHOW (0x05, no args, Write Only)

Sending the SHOW command will cause the output to update. There's no arguments/ data after the command

---

# EEPROM

The EEPROM module provides persistent storage of data across reboots.

On the SAMD09, there are 64 bytes of emulated EEPROM available for use. Byte 63 (0x3F) can be written to change the devices default I2C address.

On the ATtiny817, there are 128 bytes of actual EEPROM available for use. Byte 127 (0x7F) can be written to change the device's default I2C address.

The module base register address for the EEPROM module is 0x0D

The SAMD09 does not have true EEPROM, but flash memory on the seesaw that performs the same function. Performing a chip erase will erase all data stored in the emulated EEPROM. Also, be aware that the emulated EEPROM has a limited write/erase cycle lifespan. Care should be taken to not write/erase too many times or you will get inconsistant results and possibly damage the FLASH! The FLASH is rated for 100,000 cycles

## Function Registers

### SAMD09

Register Address	Function Name	Register Size	Notes
0x00 - 0x3E	General Purpose EEPROM	8 bits each	Read/Write
0x3F	I2C Address	8 bits	Read/Write

### ATtiny817

Register Address	Function Name	Register Size	Notes
------------------	---------------	---------------	-------

0x00 - 0x7E	General purpose EEPROM	8 bits each	Read/write
0x7F	I2C Address	8 bits	Read/write

## PWM

0x08	Base Register Address
------	-----------------------

This module provides support for Pulse Width Modulation (PWM) output.

## Nomenclature

The seesaw PWM Function Registers are defined using a generic nomenclature as follows:

- PWM Number - Specifies a specific PWM output (pin).
- PWM Value - Specifies the PWM duty cycle.
- PWM Frequency - Specifies the PWM frequency.

See the Port Specific Details section below for further information.

## Function Register Summary

Register Address	Register Name	Register Size	Access
0x01	PWM_VAL	3 bytes	W
0x02	PWM_FREQ	3 bytes	W

# Function Register Description

## 0x01 - PWM\_VAL

Byte 0	Byte 1	Byte 2
PWM Number	PWM Value MSB	PWM Value LSB

Sets the PWM Value for a specified PWM Number. The first byte written is the PWM Number. The next two bytes are the 16 bit PWM Value, most significant byte (MSB) followed by least significant byte (LSB).

## 0x02 - PWM\_FREQ

Byte 0	Byte 1	Byte 2
PWM Number	PWM Frequency MSB	PWM Frequency LSB

Sets the PWM Frequency for a specified PWM Number. The first byte written is the PWM Number. The next two bytes are the 16 bit PWM Frequency, most significant byte (MSB) followed by least significant byte (LSB).

# Port Specific Details

## SAMD

PWM outputs are available on pins PA04, PA05, PA06, and PA07. The PWM Number for each is shown in the table below.

PWM Number	Output Pin
------------	------------

0	PA04
1	PA05
2	PA06
3	PA07

The full 16 bit PWM Value is used. This value should be an unsigned integer ranging from 0 for full off to 65535 for full on.

The PWM Frequency is a 16 bit unsigned integer value which specifies the frequency in hertz (Hz).

## ATtiny

The PWM Number is the Arduino GPIO pin number.

Currently, only the MSB of the 16 bit PWM Value is used. This is due to the 8 bit limit of `analogWrite()` used internally. However, a full 16 bit value should be sent from 0 for full off to 65535 for full on.

The PWM Frequency is a 16 bit unsigned integer value which specifies the frequency in hertz (Hz). (NOTE: uses `tone()` internally)

---

## UART

Note that the default firmware on the SAMD09 breakout does not include UART support.

When the UART module is configured, the seesaw can act as an I2C UART bridge.

UART Pins are:

RX: PA11

TX: PA10

The module base register address for the UART is 0x02.

The I2C <-> UART bridge is still in beta at the time of writing this guide. Detailed specs are not yet available.

## Function Registers

Register Address	Register Name	Register Size	Notes
0x00	STATUS	8 bits	Read Only
0x02	INTEN	8 bits	Read/Write
0x03	INTENCLR	8 bits	Write Only
0x04	BAUD	32 bits	Read/Write
0x05	DATA	32 bytes	Read/Write

## Status (0x00, 8bits, Read Only)

bits 7-2	bit 1	bit 0
Reserved	DATA_RDY	ERROR

The ERROR bit is set when the UART encounters an error.

The DATA\_RDY bit is set when there is data available in the RX buffer. This bit gets cleared when the data is read.

## INTEN (0x2, 8bits, Read/Write)

bits 7-1	bit 0
Reserved	DATA_RDY

If the DATA\_RDY bit is set, the interrupt will fire when there is data in the RX buffer.

Writing zeros to this register has no effect.

## INTENCLR (0x03, 8bits, Write Only)

same bits as INTEN. Writing 1 to any bit in this register disabled the corresponding interrupt.

Writing zeros to this register has no effect.

## BAUD (0x04, 32bits, Read/Write)

Writing to this register sets the BAUD rate.

Default 9600

## DATA (0x05, 32bytes, Read/Write )

Writing to the DATA register puts the data into the TX buffer to be output on the TX pin.

Reading from the DATA register reads the data from the RX buffer.



When this register is read, the DATA\_RDY bit is cleared.

## Downloads

## Documents

- [Seesaw Arduino Driver \(\)](#)
- [Seesaw CircuitPython Driver \(\)](#)
- [Fritzing object in the Adafruit Fritzing library \(\)](#)
- [SAMD09 breakout PCB files \(EAGLE format\) \(\)](#)
- [SAMD09 datasheet \(\)](#)

## Schematic

click to enlarge

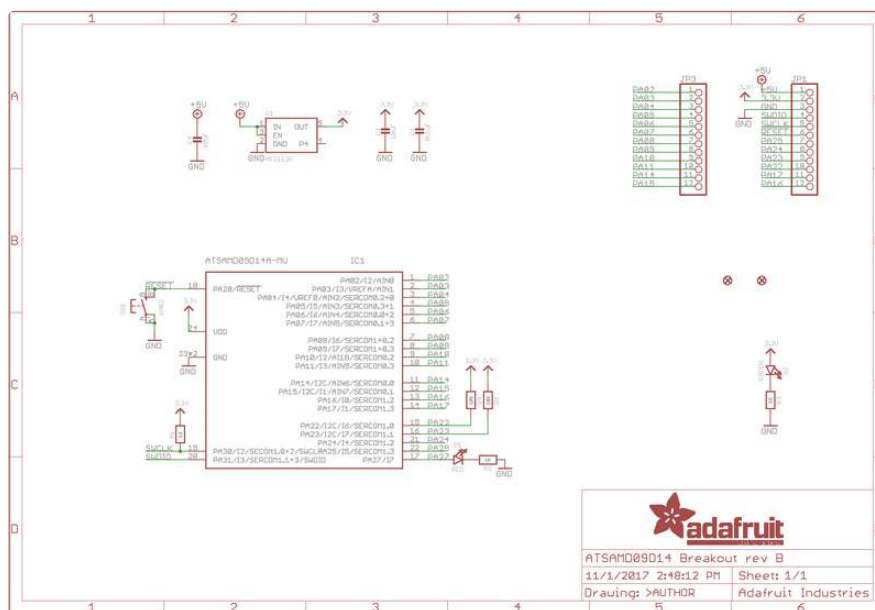

## Dimensions

in inches. Click to enlarge

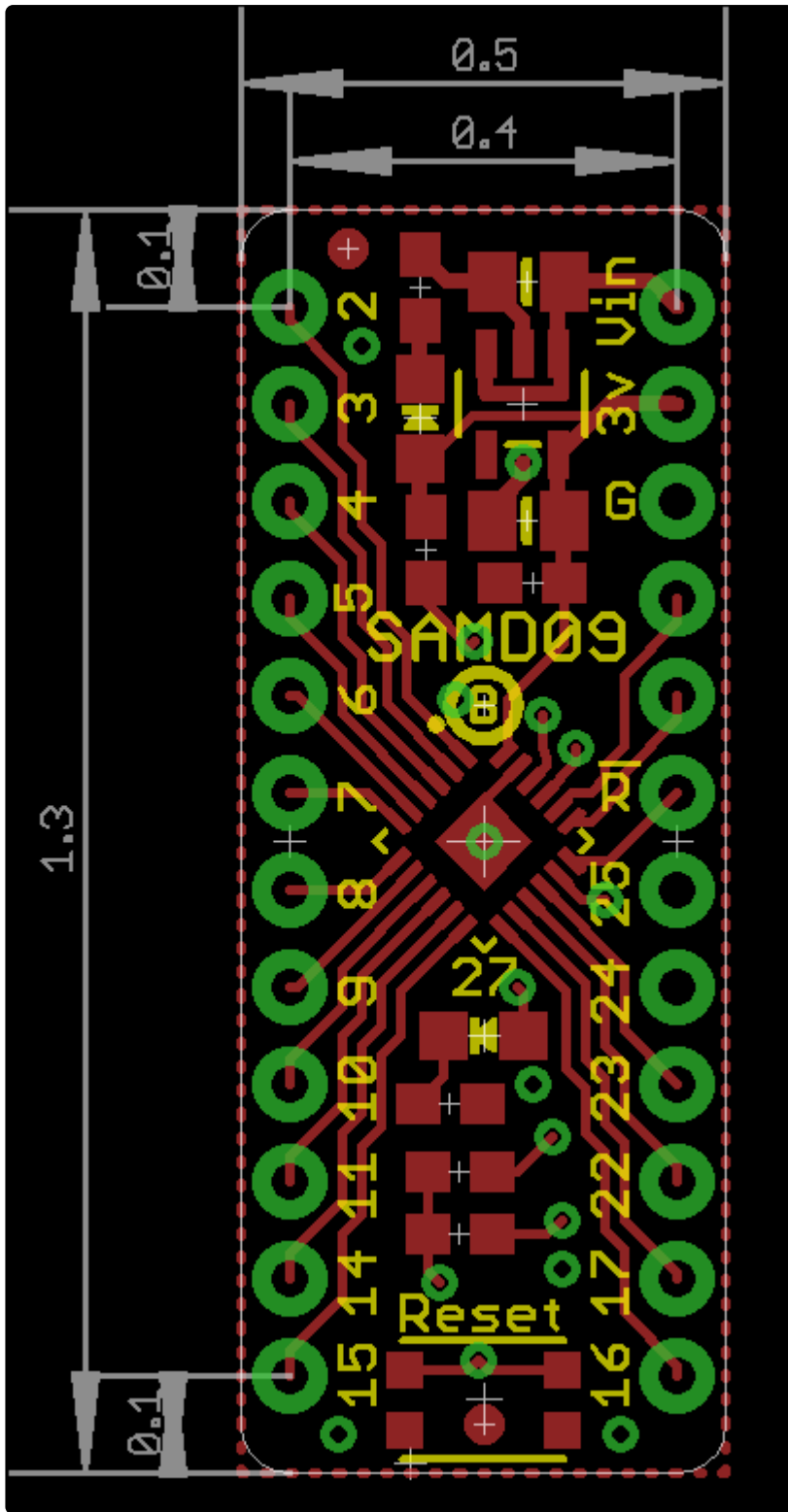

## Documentation

- [Python API Documentation \(\)](#)
- [Arduino API Documentation \(\)](#)