

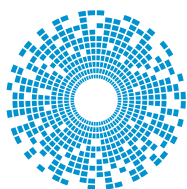

MD Series



cinch
CONNECTIVITY SOLUTIONS
a bel group

About Bel

Bel is a publicly traded company that has been operated by the same family for over 65 years. Our history of organic growth and acquisitions have broadened our product portfolio. This has established Bel as a world leader with a diverse offering of power, protection and interconnect products. We design and manufacture these products which are primarily used in the networking, telecommunications, computing, military, aerospace, transportation and broadcasting industries. Bel's portfolio of products also finds application in the automotive, medical and consumer electronics markets.

About Cinch Mil/Aero Circulars

Cinch Mil/Aero Circulars connectors and custom connectors available with hermetic sealing in any circular connector configuration. These glass-sealed packages are used mostly in critical components and assemblies for aerospace use, where leakage must be prevented even under extreme changes in temperature, pressure, and humidity.

Cinch's MD Connectors deliver highly reliable performance equal to MIL-DTL-38999. Key Markets are military, aerospace, and down-hole applications. The MD is offered at a reduced size and weight.

Table of Contents

MD801 Series

Introduction	3
Insert Arrangement	4
Shell Keying	4

Dual-Start ACME Thread with PC Tail or Solder Cups

Insert Arrangement	10
Shell Keying	10
Ordering Information	11
Receptacles with PC Tail	12

Dual-Start ACME Thread with Crimp Contacts

Ordering Information	5
Plugs	6
In-Line Receptacles	7
Square Flange Receptacles	8
Jam Nut Receptacles	9

Introduction



The MD 801 Series connector features a Dual-Start ACME thread for protection against cross mating and vibration. Designed for military and aerospace, the shells can be ordered in aluminum or stainless steel, with several options for finishes. The connectors are available as plugs or receptacles with standard crimp or PC Tail contacts, for board mount applications. Available in shell sizes 5 through 13 with multiple insert arrangement configurations.

- Miniature 38999 Plug with Solder or Crimp Contacts
- Miniature 38999 Jam Nut or Box Mount Receptacle with Solder, Crimp or PC Tail Contacts
- Standard or Specialty Platings Available

Features

- Full Performance in Extreme Environments
- Available in Crimp, Solder and PC Tail Terminations
- Shell Styles Include Jam Nut Receptacle, Square Flange Receptacle and In-Line Plugs
- Available in 6, 7, 8, 9, 10, 13 Shell Sizes
- Contact Arrangements Range from 1 to 130 Contacts

MD Connectors, Tools and Sealing Plugs						MD Crimp Tools	
Contact Size	Wire Size Range	Pin Contacts	Sockets	Sealing Plugs	Insertion Removal Tool	Crimp Tool Mil Spec	Positioner Mil Spec or Daniels
23	#22-#28	806-0060-210	857-0060-210	None	None	M22520/1-01	K1461
20	#20-#24	M39029/58-363	M39029/57-357			M22520/2-01	M22520/1-04
16	#16-#20	M39029/58-364	M39029/57-358			M22520/1-01	M22520/1-04
12	#12-#14	M39029/58-365	M39029/57-359			M22520/1-01	M22520/1-04

Specifications

Current Rating	#23-5 A
Dielectric Withstanding Voltage	#23-750 VAC
Insulation Resistance	5000 MΩ minimum
Operating Temperature	-65° C. to +175° C
Shock	300 g
Vibration	37 g
Shielding Effectiveness	55dB min from 100MHz – 1000MHz
Durability	2000 mating cycles
IP Rating	IP67 Mated

Insert Arrangement

Figure 1



5-3 Arrangement
3 Contacts
#23 Size Contacts



6-4 Arrangement
4 Contacts
#23 Size Contacts



6-6 Arrangement
6 Contacts
#23 Size Contacts



6-7 Arrangement
7 Contacts
#23 Size Contacts

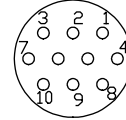

7-10 Arrangement
10 Contacts
#23 Size Contacts

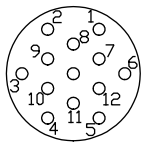

8-13 Arrangement
13 Contacts
#23 Size Contacts

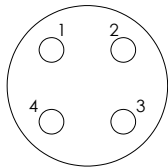

9-4 Arrangement
4 Contacts
#16 Size Contacts

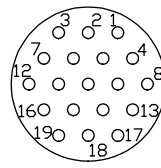

9-19 Arrangement
19 Contacts
#23 Size Contacts

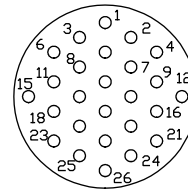

10-26 Arrangement
26 Contacts
#23 Size Contacts

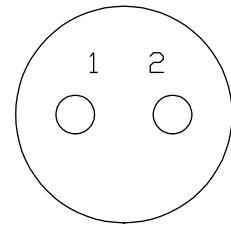

13-2 Arrangement
2 Contacts
#12 Size Contacts

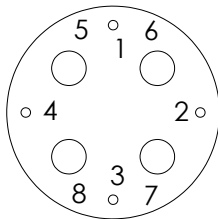

13-205 Arrangement
4-#12 Contacts
4-#23 contacts

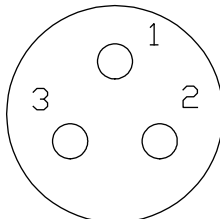

13-3 Arrangement
3 Contacts
#12 Size Contacts

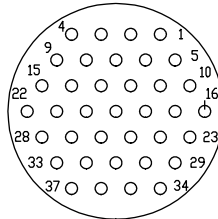

13-37 Arrangement
37 Contacts
#23 Size Contacts

Shell Keying

Table 2 - Plug Shell Keying

Position	A°	B°	C°	D°	E°	F°
A	150°	75°	95°	140°	75°	95°
B	210°	210°	230°	275°	275°	210°

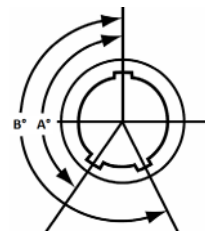
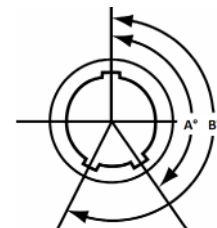
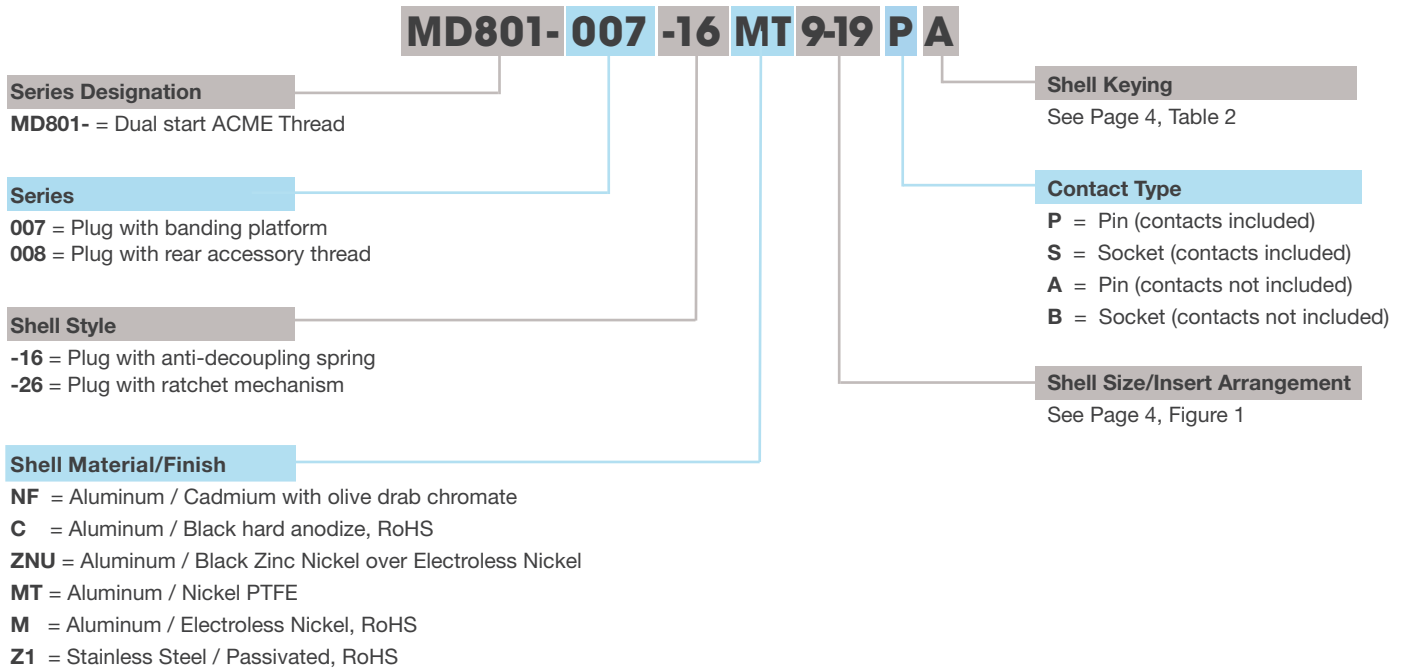

Table 3 - Receptacle Shell Keying

Position	A°	B°	C°	D°	E°	F°
A	150°	75°	95°	140°	75°	95°
B	210°	210°	230°	275°	275°	210°



Plug Ordering Information



Receptacle Ordering Information

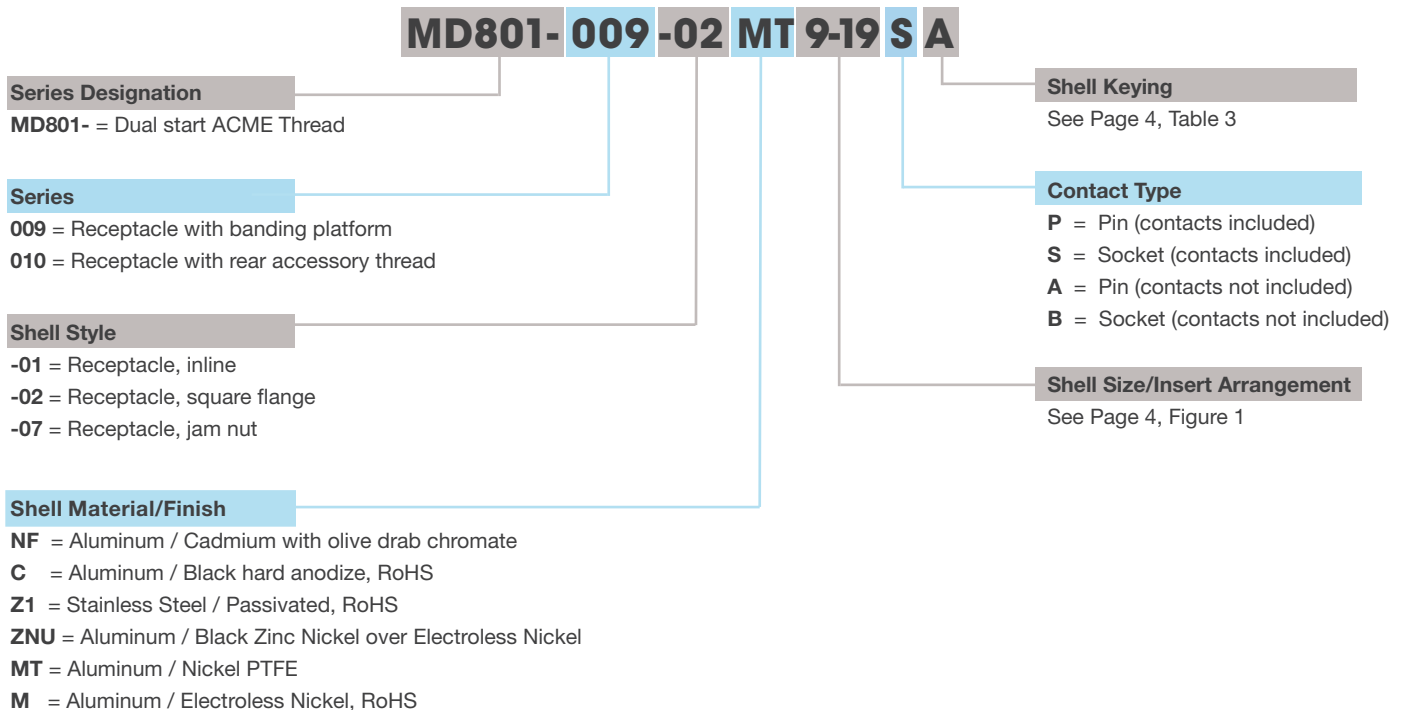

Dual-Start ACME Thread with Crimp Contacts

Plugs



MD801-007, Plug with Banding Platform

MD801-007-XXXXX-XXX

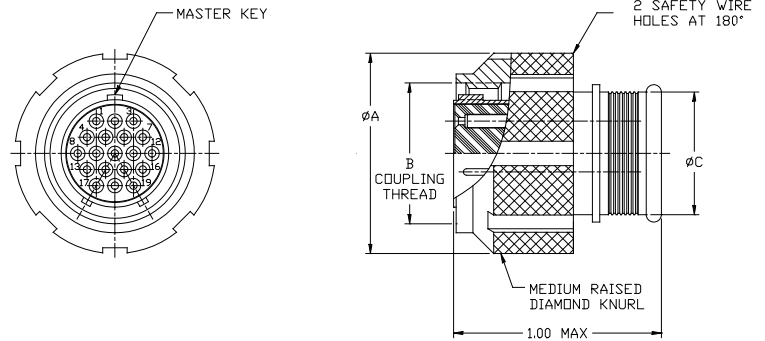

MD801-008, Plug with Rear Accessory Thread

MD801-007-XXXXX-XXX

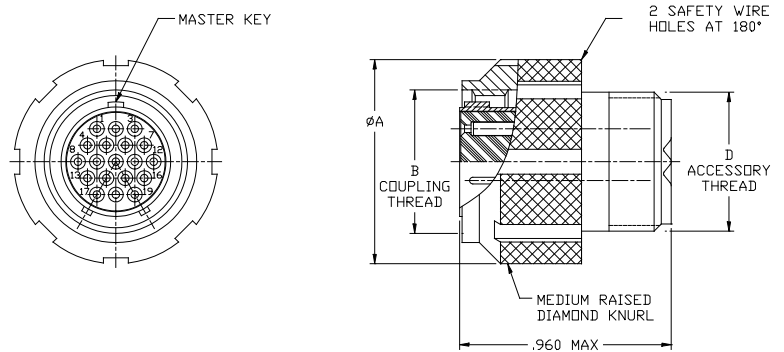

Dimensions

Shell Size	ØA		ØB	ØC	D
	Style 16	Style 26	Thread		Thread
5	0.54 (13.72)	0.65 (16.51)	0.3125-0.05P-0.1L-DS-2B	0.245 (6.22)	0.2500-32 UNEF-2A
6	0.60 (15.24)	0.69 (17.53)	0.3750-0.05P-0.1L-DS-2B	0.290 (7.37)	0.3125-32 UNEF-2A
7	0.69 (17.53)	0.79 (20.07)	0.4375-0.05P-0.1L-DS-2B	0.390 (9.91)	0.4375-28 UNEF-2A
8	0.75 (19.05)	0.83 (21.08)	0.5000-0.05P-0.1L-DS-2B	0.445 (11.30)	0.5000-28 UNEF-2A
9	0.81 (20.57)	0.92 (23.37)	0.5625-0.05P-0.1L-DS-2B	0.500 (12.70)	0.5625-24 UNEF-2A
10	0.88 (22.35)	0.98 (24.89)	0.6250-0.05P-0.1L-DS-2B	0.560 (14.22)	0.6250-24 UNEF-2A
13	1.05 (26.67)	1.10 (27.94)	0.81250-.1P-0.2L-DS-2B	0.650 (16.51)	0.6875-24 UNEF-2A

Dual-Start ACME Thread with Crimp Contacts

In-Line Receptacles



MD801-009, In-Line Receptacle with Banding Platform

MD801-009-01XXX-XXX

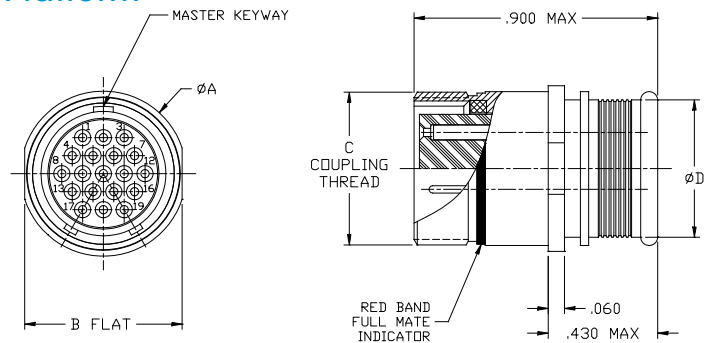

MD801-010, In-Line Receptacle with Rear Accessory Thread

MD801-010-01XXX-XXX

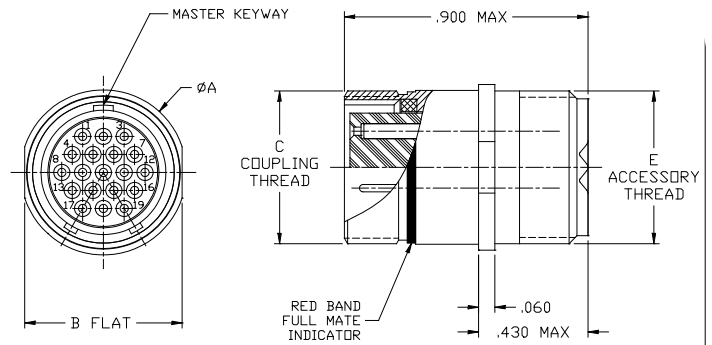

Dimensions

Shell Size	ØA	B Flat	Thread	ØD	E Thread
5	0.355 (9.02)	0.325 (8.25)	0.3125-0.05P-0.1L-DS-2B	0.245 (6.22)	0.2500-32 UNEF-2A
6	0.415 (10.54)	0.385 (9.78)	0.3750-0.05P-0.1L-DS-2B	0.290 (7.37)	0.3125-32 UNEF-2A
7	0.480 (12.19)	0.445 (11.30)	0.4375-0.05P-0.1L-DS-2B	0.390 (9.91)	0.4375-28 UNEF-2A
8	0.540 (13.72)	0.510 (12.95)	0.5000-0.05P-0.1L-DS-2B	0.445 (11.30)	0.5000-28 UNEF-2A
9	0.605 (15.37)	0.575 (14.60)	0.5625-0.05P-0.1L-DS-2B	0.500 (12.70)	0.5625-24 UNEF-2A
10	0.665 (16.89)	0.635 (16.13)	0.6250-0.05P-0.1L-DS-2B	0.560 (14.22)	0.6250-24 UNEF-2A
13	0.855 (21.72)	0.825 (20.96)	0.81250-.1P-0.2L-DS-2B	0.650 (16.51)	0.6875-24 UNEF-2A

Dual-Start ACME Thread with Crimp Contacts

Square Flange Receptacles



MD801-009, Square Flange Receptacle with Banding Platform

MD801-009-02XXX-XXX

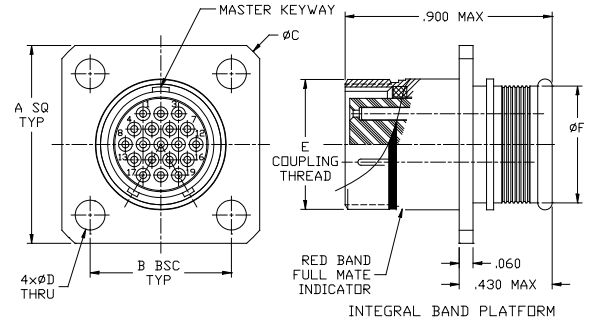

MD801-010, Square Flange Receptacle with Rear Accessory Thread

MD801-010-02XXX-XXX

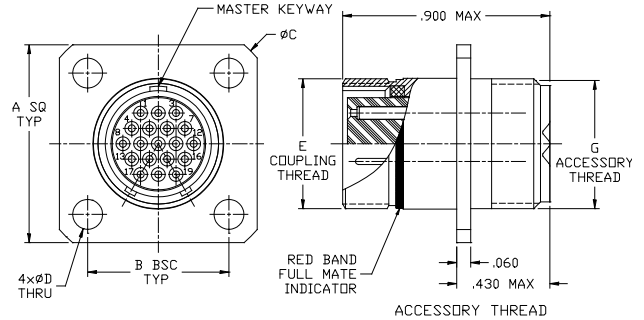

Dimensions

Shell Size	A	B	ØC	ØD	ØE	E	ØF	G
	SQ	BSC						
5	0.530 (13.46)	0.363 (9.22)	0.680 (17.27)	0.096 (2.44)	0.091 (2.31)	0.3125-0.05P-0.1L-DS-2A	0.245 (6.22)	0.2500-32 UNEF-2A
6	0.590 (14.99)	0.423 (10.74)	0.750 (19.05)	0.096 (2.44)	0.091 (2.31)	0.3750-0.05P-0.1L-DS-2A	0.290 (7.37)	0.3125-32 UNEF-2A
7	0.6550 (16.51)	0.483 (12.27)	0.850 (21.59)	0.096 (2.44)	0.091 (2.31)	0.4375-0.05P-0.1L-DS-2A	0.390 (9.91)	0.4375-28 UNEF-2A
8	0.712 (18.08)	0.545 (13.84)	0.938 (23.83)	0.096 (2.44)	0.091 (2.31)	0.5000-0.05P-0.1L-DS-2A	0.445 (11.30)	0.5000-28 UNEF-2A
9	0.850 (21.59)	0.607 (15.42)	1.125 (28.58)	0.130 (3.30)	0.126 (3.20)	0.525-0.05P-0.1L-DS-2S	0.500 (12.70)	0.5625-24 UNEF-2A
10	0.890 (22.61)	0.670 (17.02)	1.188 (30.18)	0.130 (3.30)	0.126 (3.20)	0.625-0.05P-0.1L-DS-2S	0.560 (14.22)	0.625-24 UNEF-2A
13	1.030 (26.16)	0.812 (20.62)	1.375 (34.92)	0.130 (3.30)	0.126 (3.20)	0.8125-0.1P-0.2L-DS-2A	0.650 (16.51)	0.6875-24 UNEF-2A

Table 4 - Panel Cutout

Shell Size	ØA	B	ØC	
	±0.005 (0.13)	BSC		
5	0.328 (8.33)	0.328 (8.33)	0.096 (2.44)	0.091 (2.31)
6	0.390 (8.33)	0.328 (8.33)	0.096 (2.44)	0.091 (2.31)
7	0.453 (11.51)	0.328 (8.33)	0.096 (2.44)	0.091 (2.31)
8	0.515 (13.08)	0.328 (8.33)	0.096 (2.44)	0.091 (2.31)
9	0.57 (14.68)	0.328 (8.33)	0.130 (3.30)	0.126 (3.20)
10	0.640 (16.26)	0.328 (8.33)	0.130 (3.30)	0.126 (3.20)
13	0.828 (21.03)	0.328 (8.33)	0.130 (3.30)	0.126 (3.20)

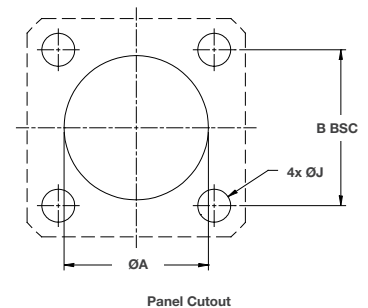

Jam Nut Receptacles

MD801-009, Jam Nut Receptacle with Banding Platform

MD801-009-07XXX-XXX

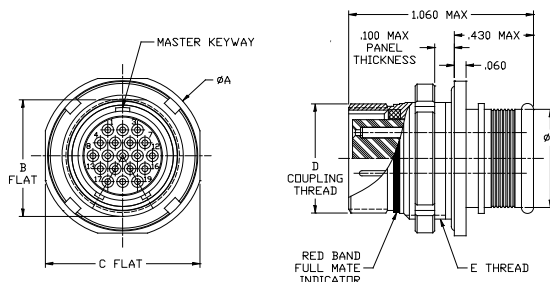

MD801-010, Jam Nut Receptacle with Rear Accessory Thread

MD801-010-07XXX-XXX

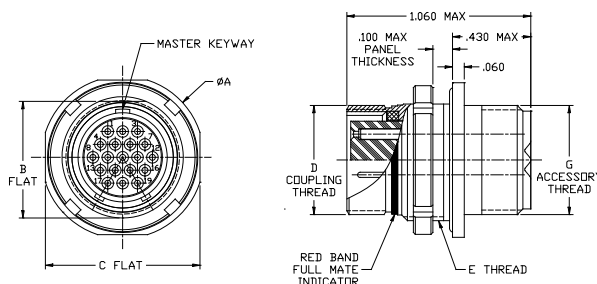

Dimensions

Shell Size	ØA	B Flat	C Flat	D Thread	E Thread	ØF	G Thread
5	0.54 (13.72)	0.65 (16.51)	0.545 (13.84)	0.3125-0.05P-0.1L-DS-2B	0.375-28 UNEF-2A	0.245 (6.22)	0.250-32 UNEF-2A
6	0.635 (16.13)	0.69 (17.53)	0.595 (15.11)	0.3750-0.05P-0.1L-DS-2B	0.4375-28 UNEF-2A	0.290 (7.37)	0.3125-32 UNEF-2A
7	0.755 (19.18)	0.79 (20.07)	0.73 (18.36)	0.4375-0.05P-0.1L-DS-2B	0.5625-32 UNEF-2A	0.390 (9.91)	0.4375-28 UNEF-2A
8	0.755 (19.18)	0.83 (21.08)	0.73 (18.36)	0.5000-0.05P-0.1L-DS-2B	0.5625-32 UNEF-2A	0.445 (11.30)	0.5000-28 UNEF-2A
9	0.830 (21.08)	0.92 (23.37)	0.790 (20.07)	0.5625-0.05P-0.1L-DS-2B	0.625-28 UNEF-2A	0.500 (12.70)	0.5625-24 UNEF-2A
10	0.890 (22.61)	0.98 (24.89)	0.855 (21.72)	0.6250-0.05P-0.1L-DS-2B	0.6875-28 UNEF-2A	0.560 (14.22)	0.6250-24 UNEF-2A
13	1.078 (27.38)	1.10 (27.94)	1.044 (26.52)	0.81250-.1P-0.2L-DS-2B	0.875-28 UNEF-2A	0.650 (16.51)	0.6875-24 UNEF-2A

Table 5 - Panel Cutout

Shell Size	A Flat ±0.002 (0.05)	ØC ±0.002 (0.13) ±0.000 (0.00)
5	0.356 (9.04)	0.380 (9.65)
6	0.416 (10.57)	0.443 (11.25)
7	0.542 (13.77)	0.567 (14.40)
8	0.542 (13.77)	0.567 (14.40)
9	0.602 (15.29)	0.630 (16.00)
10	0.664 (16.87)	0.693 (17.60)
13	0.851 (21.62)	0.880 (22.35)

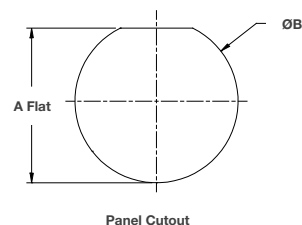

Dual-Start ACME Thread with PC Tails

Receptacle Ordering Information

MD801- 011 -02 MT 9-19 S A

Series Designation

MD801- = Dual start ACME Thread

Series

011 = Receptacle for PC tail or solder cup contacts

033 = Receptacle for PC tail or solder cup contacts, water immersion

Shell Style

-02 = Receptacle, square flange

-07 = Receptacle, jam nut

-12 = Receptacle, square flange, rear panel mount with non-locking clinch nuts

-22 = Receptacle, square flange, rear panel mount with locking clinch nuts

Shell Material/Finish

NF = Aluminum / Cadmium with olive drab chromate

C = Aluminum / Black hard anodize, RoHS

Z1 = Stainless Steel / Passivated, RoHS

ZNU = Aluminum / Black Zinc Nickel over Electroless Nickel

MT = Aluminum / Nickel PTFE

M = Aluminum / Electroless Nickel, RoHS

Shell Keying

See Table 3 (Receptacle)

Contact Type

P = Pin, PC Tail

S = Socket, PC Tail

E = Pin, Solder Cup

F = Socket, Solder Cup

Shell Size/Insert Arrangement

See Page 10, Figure 1

Dimensions

Shell Size	A Sq	B Bsc	ØC	ØD	E Flat	F Flat	J Holes	K Thread	L Thread	ØM	ØT
5	0.530 (13.46)	0.363 (9.22)	0.680 (17.27)	0.575 (14.60)	0.545 (13.84)	0.350 (8.89)		0.3125-0.05P-0.1L2A	0.375-28 UNEF-2A	0.244 (6.20)	0.175 (4.44)
6	0.590 (14.99)	0.423 (1.74)	0.750 (19.05)	0.635 (16.13)	0.595 (15.11)	0.410 (1.41)	0.096 (2.44) 0.91 (2.31)	0.375-0.05P-0.1L2A	0.4375-28 UNEF-2A	0.330 (8.38)	0.238 (6.05)
7	0.650 (16.51)	0.483 (12.27)	0.850 (21.59)	0.755 (19.18)	0.723 (18.36)	0.536 (13.61)		0.4375-0.05P-0.1L2A	0.5625-32 UNEF-2A	0.432 (10.97)	0.327 (8.31)
8	0.712 (18.08)	0.545 (13.84)	0.938 (23.83)	0.755 (19.18)	0.723 (18.36)	0.536 (13.61)		0.5000-0.05P-0.1L2A	0.5625-32 UNEF-2A	0.493 (12.52)	0.388 (9.86)
9	0.850 (21.59)	0.607 (15.42)	1.125 (28.58)	0.830 (22.61)	0.790 (2.07)	0.506 (15.14)		0.5625-0.05p-0.1L2A	0.6250-28 UNEF-2A	0.551 (14.00)	0.446 (11.33)
10	0.890 (22.61)	0.607 (15.42)	1.188 (3.18)	0.890 (22.61)	0.855 (21.72)	0.658 (16.71)	0.130 (3.30) 0.126 (3.11)	0.6250-0.05p-0.1L2A	0.6875-28 UNEF-2A	0.620 (15.75)	0.516 (13.11)
13	1.030 (26.16)	0.812 (2.62)	1.375 (34.92)	1.078 (27.38)	1.044 (26.52)	0.845 (21.46)		0.812-1P-0.2L2A	0.8750-28 UNEF-2A	0.703 (17.86)	0.599 (15.21)

Dimensions (continued)

Shell Size	A Flat ±0.002 (0.05)	ØC ±0.002 (0.13) ±0.000 (0.00)	N Flat ±0.002 (0.05)	Ø P +0.005 (+0.13) -0.000 (-0.00)	Ø R ±0.005 (0.13)	Ø U	V Sq	W Clinch Nuts	X
5	0.356 (9.04)	0.380 (9.65)	0.356 (9.04)	0.380 (9.65)	0.328 (8.33)	0.774 (19.66)	0.623 (15.82)		
6	0.416 (10.57)	0.443 (11.25)	0.416 (10.57)	0.443 (11.25)	0.390 (9.91)	0.860 (21.84)	0.683 (17.35)	2-56	0.030 (0.76)
7	0.542 (13.77)	0.567 (14.40)	0.542 (13.77)	0.567 (14.40)	0.453 (11.51)	0.944 (23.98)	0.743 (18.87)		
8	0.542 (13.77)	0.567 (14.40)	0.542 (13.77)	0.567 (14.40)	0.515 (13.08)	1.032 (26.21)	0.805 (20.45)		
9	0.602 (15.29)	0.630 (16.00)	0.602 (15.29)	0.630 (16.00)	0.578 (14.68)	1.180 (29.97)	0.927 (23.55)		
10	0.664 (16.87)	0.693 (17.60)	0.666 (16.92)	0.693 (17.60)	0.640 (16.26)	1.268 (32.21)	0.990 (25.15)	4-40	0.060 (1.52)
13	0.851 (21.62)	0.880 (22.35)	0.851 (21.62)	0.880 (22.35)	0.828 (21.03)	1.470 (37.34)	1.132 (28.75)		

Table 6 - PC Tail Diameter

Contact Size	ØS
#23	Ø 0.018/0.022
#20	Ø 0.028/0.024
#16	Ø 0.060/0.064
#12	Ø 0.092/0.096

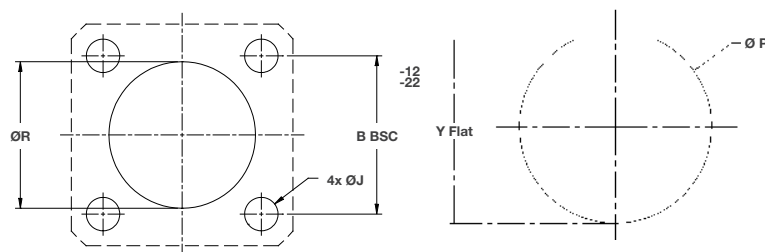

Recommended Panel Cutouts

Receptacles



MD801-011-02/MD801-033-02 Square Flange Receptacle

MD801-011-02XXX-XXX

MD801-033-02XXX-XXX

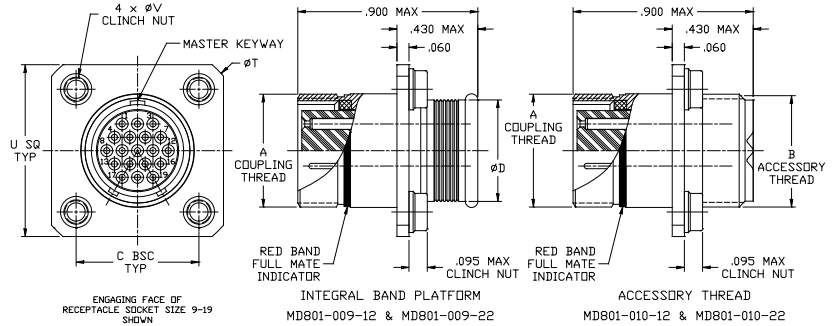

MD801-011-07/MD801-033-07 Jam Nut Receptacle

MD801-011-02XXX-XXX

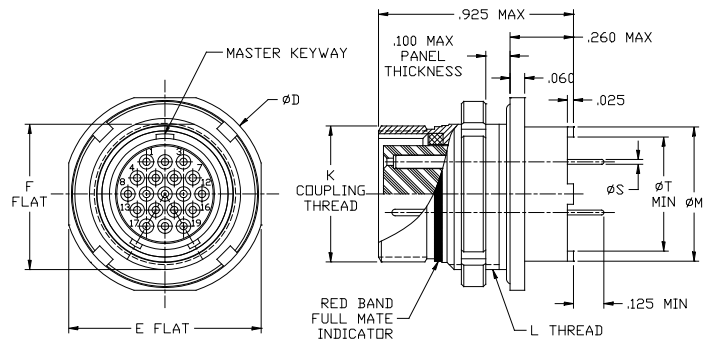

MD801-011/MD801-033 Square Flange Receptacle

MD801-011-02XXX-12XX

MD801-011-02XXX-22XX

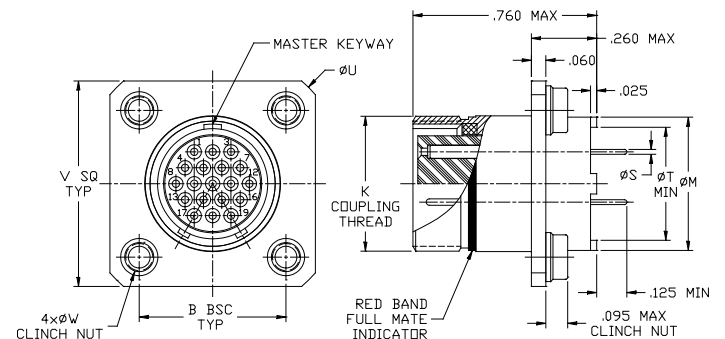



About Cinch Connectivity Solutions

For over 100 years, Cinch Connectivity Solutions has manufactured high-quality and reliable high-performance connectors and cable assemblies. Cinch is recognized as a world class connectivity supplier of RF, fiber optic, hybrid, microwave components, circular, d-subminiatures, modular rectangular, electronic enclosures and cable assemblies.

Cinch provides innovative solutions to the military, commercial aerospace, networking, telecommunication, test and measurement, oil and gas and other harsh environment industries.



For more information, please contact us:

North America
+1 507.833.8822
ccsorders@us.cinch.com

Asia-Pacific
+86 21 5442 7668
ccs.asia.sales@as.cinch.com

Europe, Middle East
+44 (0) 1245 342060
CinchConnectivity@eu.cinch.com



belfuse.com/cinch.com