

AEC-Q100 Qualified 40V 3A/5A/8A Synchronous Step-Down Regulators

OVERVIEW

XR76203-Q	40V, 3A
XR76205-Q	40V, 5A
XR76208-Q	40V, 8A

FEATURES

- Automotive AEC-Q100 Qualified
 - Temperature Grade 1: -40°C to 125°C
 - HBM ESD Class Level 2
 - CDM ESD Class Level C4B
- Controller, drivers, bootstrap diode and MOSFETs integrated in one package
- 3A, 5A and 8A step-down regulators
 - 5.5V to 40V operating range
 - 3V to 40V PV_{IN} with 5V bias
 - $\geq 0.6V$ adjustable output voltage
- Patented COT control
 - Programmable 200ns to 2 μ s on-time
 - Constant 100kHz to 800kHz frequency
- Selectable CCM or CCM/DCM
 - CCM/DCM for high efficiency at light load
 - CCM for constant frequency at light load
- Programmable hiccup current limit with thermal compensation
- Precision enable and Power Good flag
- Programmable soft-start
- Common scalable footprint 30-pin, 5mm x 5mm QFN package with wettable flanks

BENEFITS

- Excellent line and load regulation compared to standard COT
- Stable with ceramic output capacitors
- No compensation required
- Fast transient response with ability to work with low ESR capacitors

APPLICATIONS

- Automotive systems
 - Infotainment head units
 - Advanced Driver Assistance Systems (ADAS)
- Distributed power architecture
- Point-of-Load (POL) converters
- Power supply modules
- FPGA, DSP and processor supplies
- Industrial and military applications

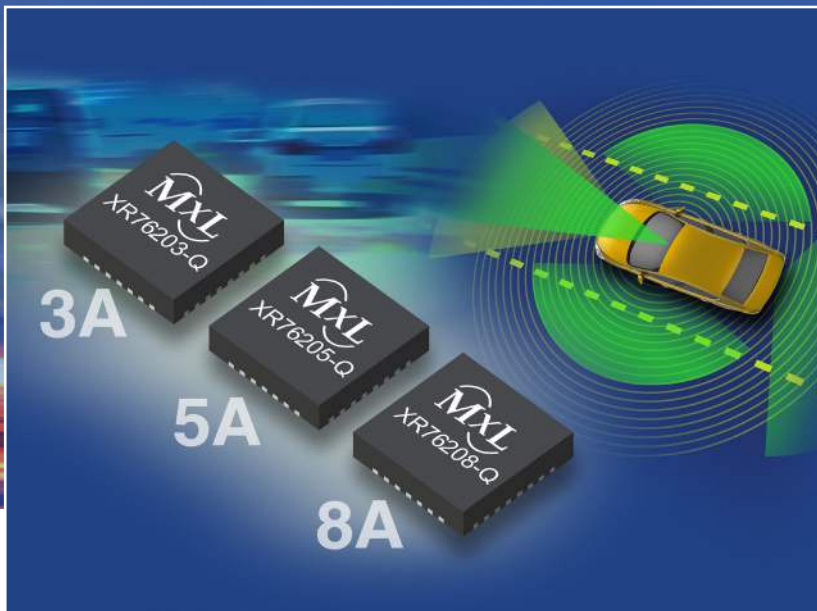

The AEC-Q100 qualified XR76203-Q, XR76205-Q and XR76208-Q are synchronous step-down regulators combining the controller, drivers, bootstrap diode and MOSFETs in a single package for point-of-load supplies well suited for automotive applications. The XR76203-Q, XR76205-Q and XR76208-Q have load current ratings of 3A, 5A and 8A, respectively. A wide 5.5V to 40V input voltage range allows for single supply operation from industry standard 24V $\pm 10\%$, 18V to 36V and rectified 18VAC and 24VAC rails and 12V battery systems requiring inherent load dump protection.

With a proprietary emulated current mode Constant On-Time (COT) control scheme, the XR76203-Q, XR76205-Q and XR76208-Q provide extremely fast line and load transient response using ceramic output capacitors. They require no loop compensation, simplifying circuit implementation and reducing overall component count. The control loop also provides 0.07% load and 0.15% line regulation and maintains constant operating frequency. A selectable power saving mode allows the user to operate in Discontinuous Conduction Mode (DCM) at light current loads thereby significantly increasing the converter efficiency. A host of protection features, including over-current, over temperature, short-circuit and UVLO, helps achieve safe operation under abnormal operating conditions. These 40V regulators deliver power to a wide range of automotive, industrial and military equipment.

Part Number	I _{OUT} (A)	V _{IN} Range (V)	V _{OUT} Range (V)	Frequency (kHz)	Accuracy (%)	Efficiency (%)	Package (mm)	Features
XR76203-Q	3	5.5 to 40	0.6 to 30	100 to 800	0.5	95	5 x 5 QFN with Wettable Flanks	<ul style="list-style-type: none"> AEC-Q100 Qualification Patented COT provides fast transient response with excellent line and load regulation UVLO, OTP, soft-start, adjustable hiccup current limit and short-circuit protection
XR76205-Q	5					96		
XR76208-Q	8					96		

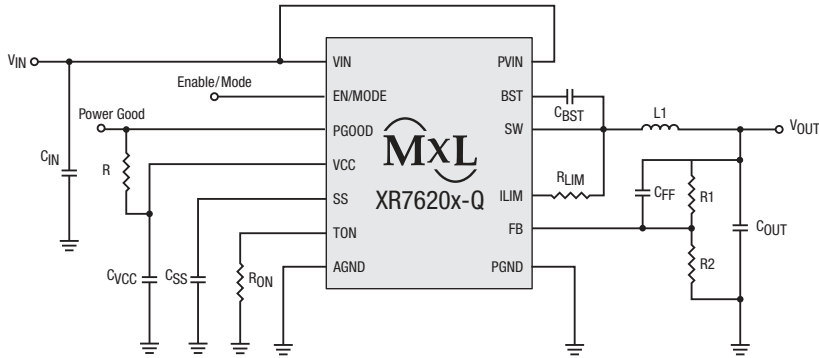

Typical Schematic

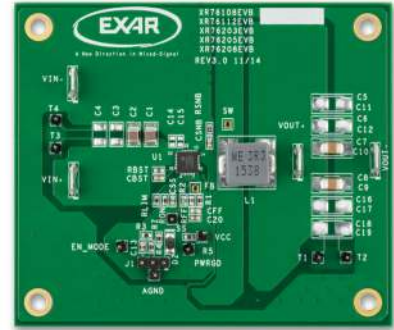

XR76203-Q/XR76205-Q/XR76208-Q Evaluation Board

XR76203-Q Efficiency

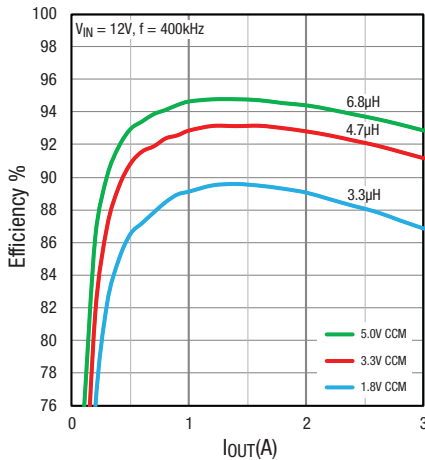

XR76205-Q Efficiency

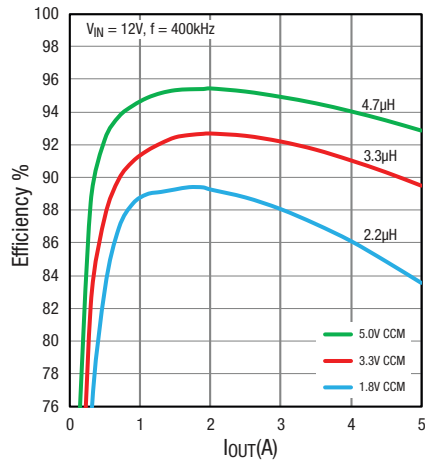

XR76208-Q Efficiency

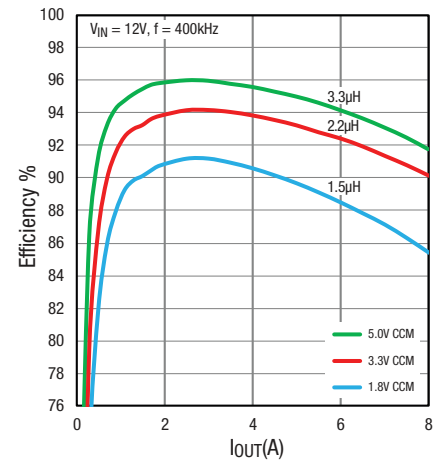

Corporate Headquarters:
 5966 La Place Court
 Suite 100
 Carlsbad, CA 92008
 Tel.: +1 (760) 692-0711
 Fax: +1 (760) 444-8598
www.maxlinear.com

The content and information contained in this document is furnished for informational or general marketing purposes only, is subject to change without notice, and should not be construed as a commitment by MaxLinear, Inc. MaxLinear, Inc. assumes no responsibility or liability for any errors, inaccuracies, or incompleteness that may appear in the informational content contained in this guide.

Reproduction, in part or whole, without the prior written consent of MaxLinear, Inc. is prohibited. MaxLinear, the MaxLinear logo, and any MaxLinear trademarks; MxL, Full-Spectrum Capture, FSC, G.now, and AirPHY are all trademarks of MaxLinear, Inc. or one of MaxLinear's subsidiaries in the U.S.A. and other countries. Other company trademarks and product names appearing herein are the property of their respective owners.

© 2019 MaxLinear, Inc. All rights reserved.