

10/100/1000 BASE-T Low Profile SMD LAN Transformer Module

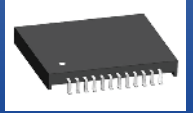

ALANL10001



19.8 x 16.6 x 2.5 mm
RoHS/RoHS II Compliant
MSL = 1

Features

- Low Profile of 2.53 mm
- Meets IEEE 802.3ab standards
- Compatible with 10 BASE-T, 100 BASE-TX, and 1000 Base-T
- RoHS Compliant
- High performance magnetics for EMI suppression and common mode noise rejection
- 1CT:1CT TX and RX Transformers

Applications

- Fast and gigabit Ethernet
- IP cameras, surveillance, and IP phone
- Industrial computers and robotics
- PC Card and Cardbus

Part Identification

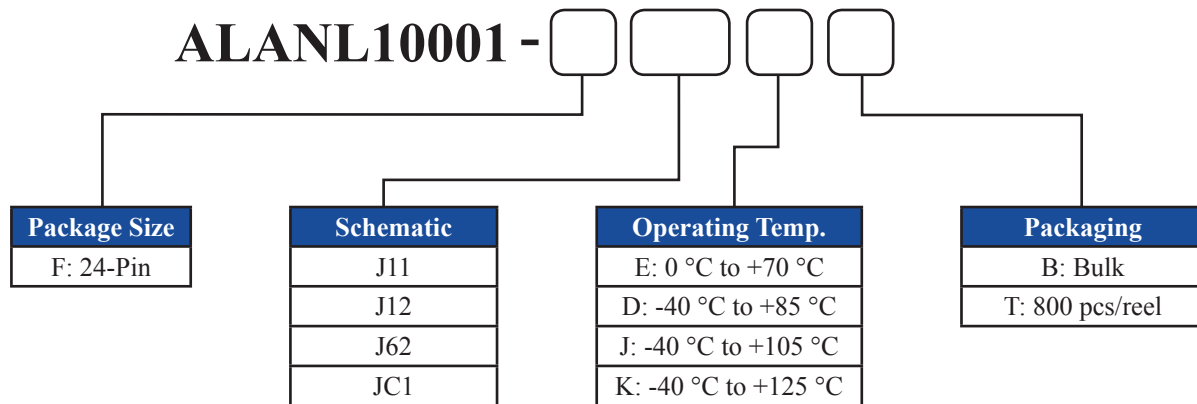

10/100/1000 BASE-T Low Profile SMD LAN Transformer Module

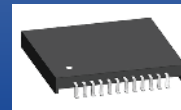

ALANL10001



19.8 x 16.6 x 2.5 mm
RoHS/RoHS II Compliant
MSL = 1

Electrical Specifications at 25°C

Part Number	Insertion Loss (dB Max)	Return Loss (dB Min)				Crosstalk (dB Min)			CMRR (dB Min)			DCMR (dB Min)		
	0.5-100 MHz	1-40 MHz	60 MHz	80 MHz	100 MHz	30 MHz	60 MHz	100 MHz	30 MHz	60 MHz	100 MHz	30 MHz	60 MHz	100 MHz
ALANL10001-FJ11	1.2	18	14.4	12	10	45	40	35	43	37	33	43	37	33
ALANL10001-FJ12	1.2	18	14.4	12	10	45	40	35	43	37	33	43	37	33
ALANL10001-FJ62	1.2	18	14.4	12	10	45	40	35	43	37	33	43	37	33
ALANL10001-FJC1	1.2	18	14.4	12	10	45	40	35	43	37	33	43	37	33

Part Number	Inductance (uH Min)	Leakage Inductance (uH Max)	Interwinding Capacitance (pF Max)	DC Resistance (Ω Max)		Hi Pot (Vrms)	Weight (g)
Test Condition	@100kHz, 0.2V, 8mA DC Bias	@100kHz, 0.2V TD to MX	@100kHz, 0.1V TD to MX	TD+ to TD-	MX+ to MX-	0.5mA/6 sec.	Per Piece
ALANL10001-FJ11	350	0.5	30	1.0	1.5	1500	1.2
ALANL10001-FJ12	350	0.5	30	1.0	1.5	1500	1.2
ALANL10001-FJ62	350	0.5	30	1.5	1.0	1500	1.2
ALANL10001-FJC1	350	0.5	30	1.0	1.5	1500	1.2

10/100/1000 BASE-T Low Profile SMD LAN Transformer Module

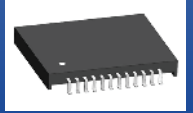

ALANL10001



19.8 x 16.6 x 2.5 mm
RoHS/RoHS II Compliant
MSL = 1

Mechanical Dimensions

F: 24-pin Option 1

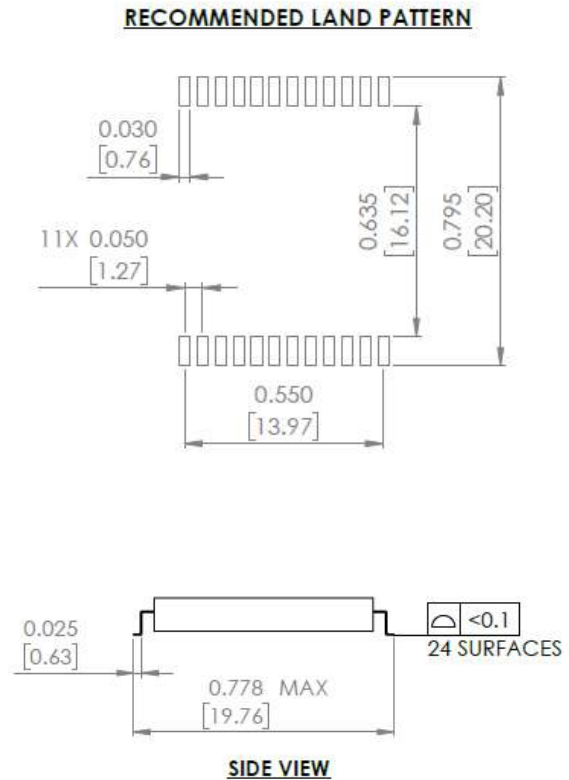
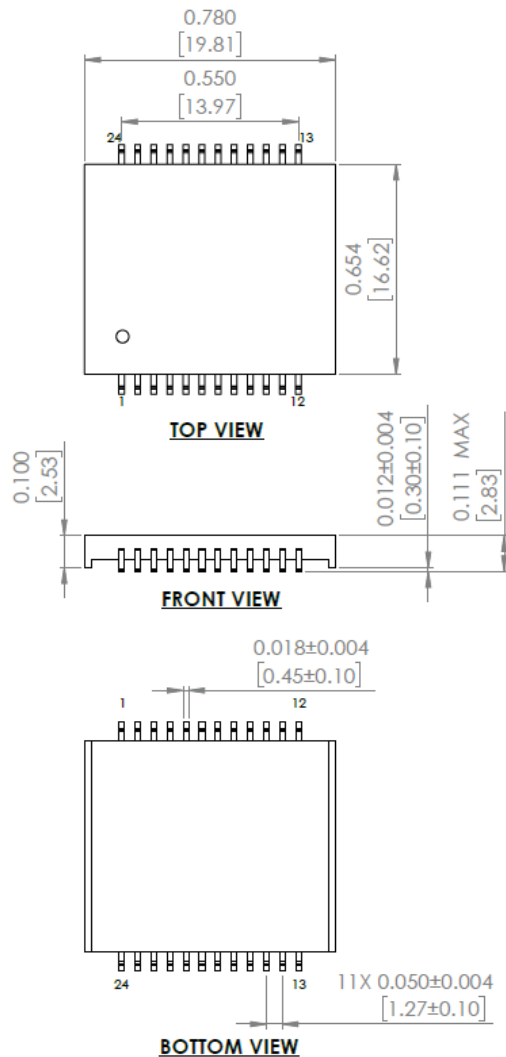

Unless otherwise specified, all tolerances are ±0.25 in mm
Dimensions: inch/ [mm]

10/100/1000 BASE-T Low Profile SMD LAN Transformer Module

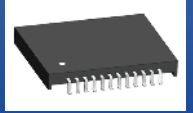

ALANL10001



19.8 x 16.6 x 2.5 mm
RoHS/RoHS II Compliant
MSL = 1

Schematics

24-Pin

J11

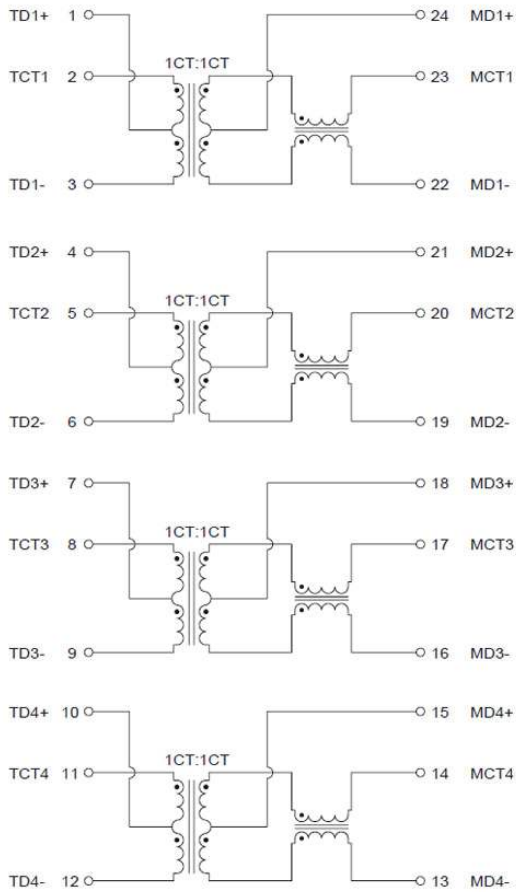

J12

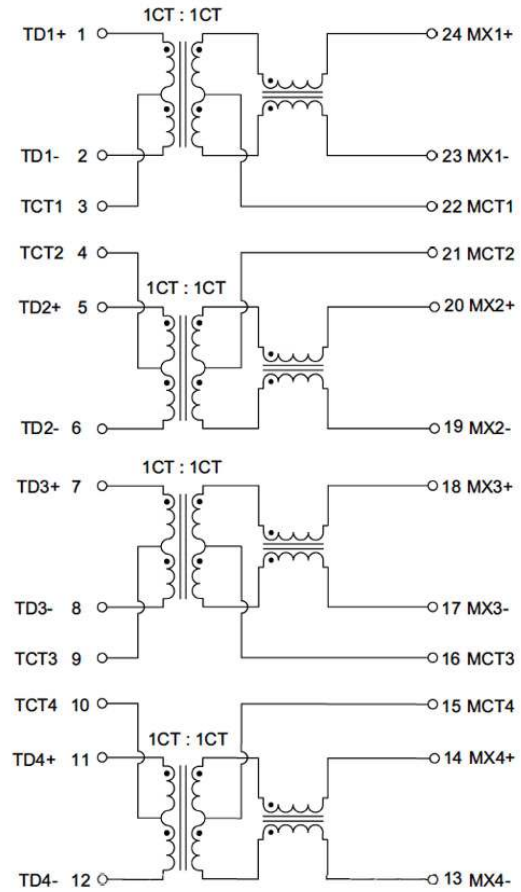

Contact Abracon for additional options.



5101 Hidden Creek Ln Spicewood TX 78669
Phone: 512-371-6159 | Fax: 512-351-8858
For terms and conditions of sales, please visit:
www.abracon.com

REVISED: 08-5-19

ABRACON IS
ISO9001-2015
CERTIFIED

10/100/1000 BASE-T Low Profile SMD LAN Transformer Module

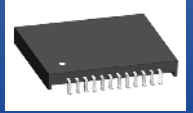

ALANL10001



19.8 x 16.6 x 2.5 mm
RoHS/RoHS II Compliant
MSL = 1

Schematics

24-Pin

J62

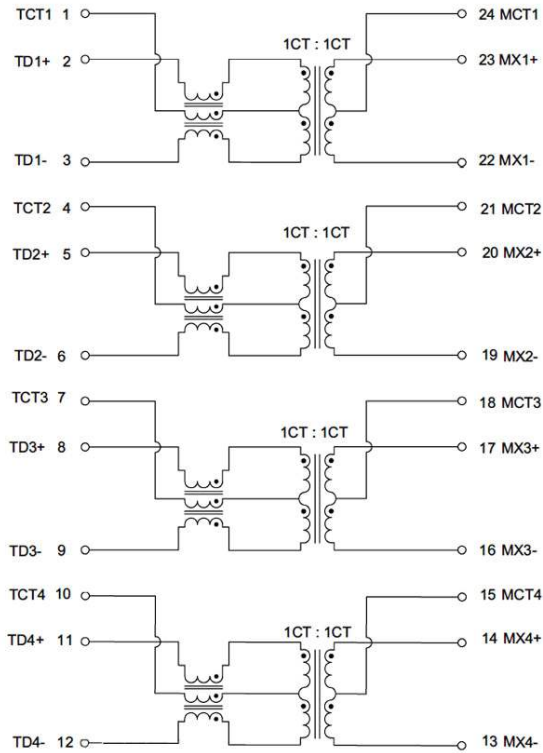

JC1

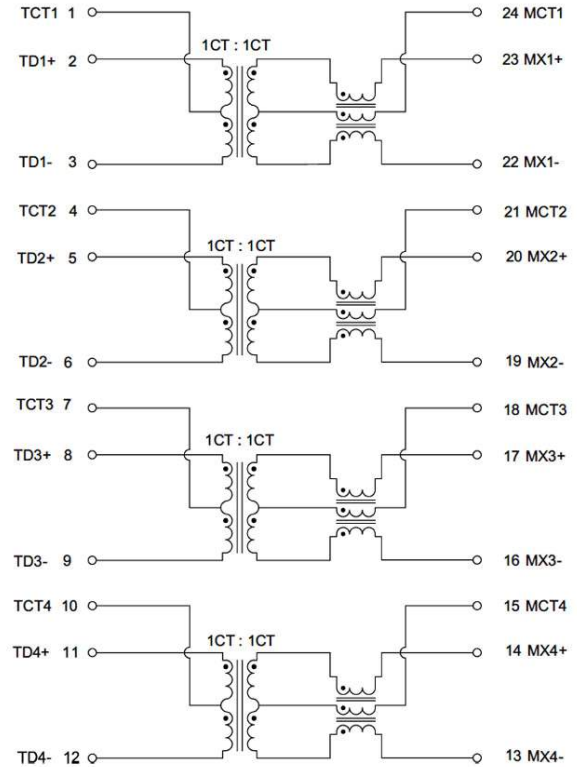

Contact Abracon for additional options.



5101 Hidden Creek Ln Spicewood TX 78669
Phone: 512-371-6159 | Fax: 512-351-8858
For terms and conditions of sales, please visit:
www.abracon.com

REVISED: 08-5-19

ABRACON IS
ISO9001-2015
CERTIFIED

10/100/1000 BASE-T Low Profile SMD LAN Transformer Module

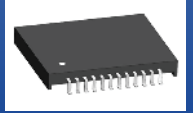

ALANL10001



19.8 x 16.6 x 2.5 mm
RoHS/RoHS II Compliant
MSL = 1

Reflow Profile

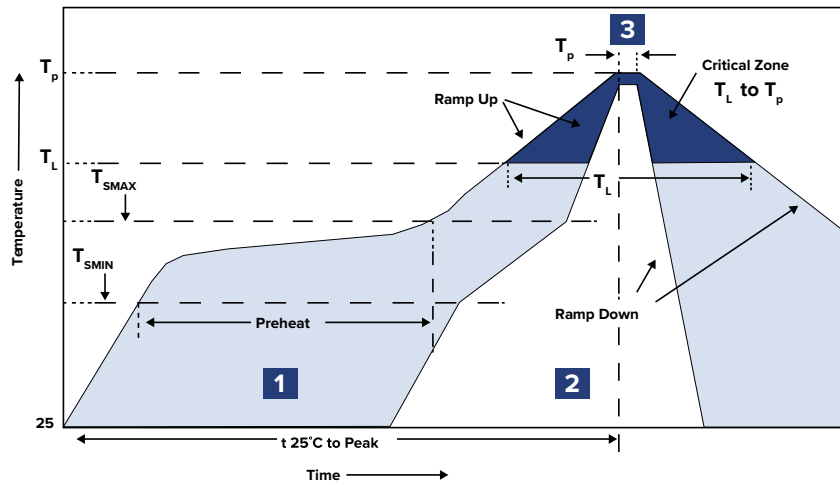

Zone	Description	Temperature	Time
1	Preheat / Soak	$T_{SMIN} \sim T_{SMAX}$ $150^{\circ}\text{C} \sim 200^{\circ}\text{C}$	60 ~ 180 sec.
2	Reflow	T_L 245°C	20 ~ 40 sec.
3	Peak heat	T_P $240^{\circ}\text{C} \pm 5^{\circ}\text{C}$	10 sec. MAX

10/100/1000 BASE-T Low Profile SMD LAN Transformer Module

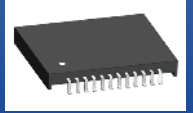

ALANL10001



19.8 x 16.6 x 2.5 mm
RoHS/RoHS II Compliant
MSL = 1

Packaging

Tape and Reel: 800 pcs
Pieces per Carton: 6,400 pcs/box
T&R per Carton: 8 T&R/box
Weight per Carton: 11.5kg
Weight per Piece: 1.2g

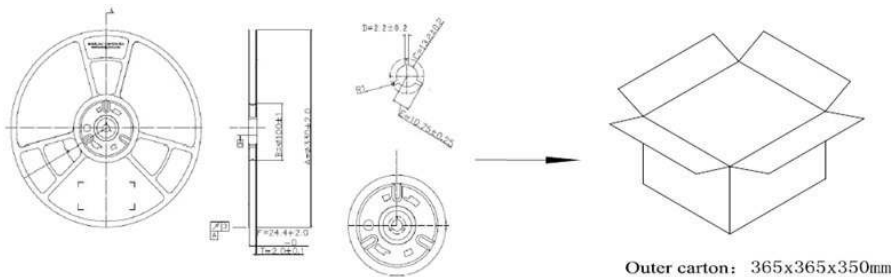
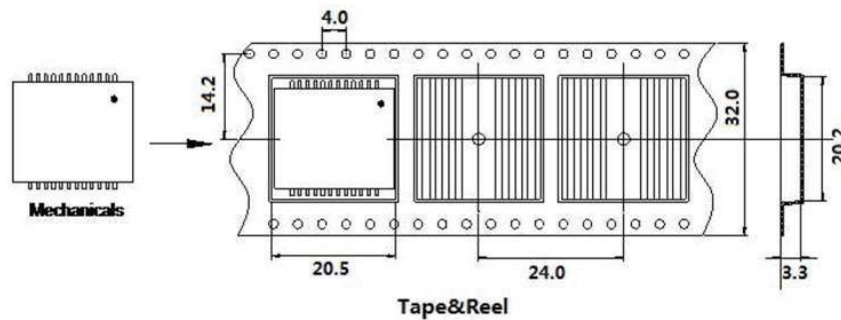

Dimensions: mm

ATTENTION: Abracon LLC's products are COTS – Commercial-Off-The-Shelf products; suitable for Commercial, Industrial and, where designated, Automotive Applications. Abracon's products are not specifically designed for Military, Aviation, Aerospace, Life-dependent Medical applications or any application requiring high reliability where component failure could result in loss of life and/or property. For applications requiring high reliability and/or presenting an extreme operating environment, written consent and authorization from Abracon LLC is required. Please contact Abracon LLC for more information.



5101 Hidden Creek Ln Spicewood TX 78669
Phone: 512-371-6159 | Fax: 512-351-8858
For terms and conditions of sales, please visit:
www.abracon.com

REVISED: 08-5-19

ABRACON IS
ISO9001-2015
CERTIFIED