

**Order Number  
200218-5000**

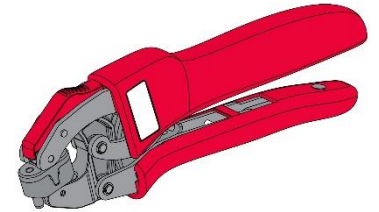

**Application Tooling Specification**

**FEATURES**

- Small handle spread makes this style tool ideally suited for end users
- Ratchet with safety release that ensures consistent performance
- Well balanced, lightweight and easy-to-use self-adjusting tool for wire ferrules
- Front and side entry support use in hard-to-reach places

**SCOPE**

Self-adjusting hand tool for crimping trapezoidal profiles on insulated and non-insulated wire ferrules manufactured to UL486F/DIN 46228 Parts 1 and 4.

**Products:** Wire ferrules 0.14-10mm<sup>2</sup> (26-8 AWG)

**Molex Ferrules:**

Ferrule	Color	AWG	mm2	Ø	d	P	L
936020004	Orange	22	0.35	2.6	0.8	6	12
936020005	White	22	0.35	2.6	0.8	6	12
936020006	Orange	22	0.35	2.6	0.8	8	14
936020007	White	22	0.35	2.6	0.8	8	14
936020008	White	22	0.35	2.6	0.8	10	16
936020001	White	20	0.5	2.6	1	6	12
936020002	White	20	0.5	2.6	1	8	14
936020003	White	20	0.5	2.6	1	10	16
936020009	Gray	18	0.75	2.8	1.2	6	12.4
936020010	White	18	0.75	2.8	1.2	6	12.4
936020011	Blue	18	0.75	2.8	1.2	8	14.6
936020012	Gray	18	0.75	2.8	1.2	8	14.6
936020013	White	18	0.75	2.8	1.2	8	14.6
936020014	Gray	18	0.75	2.8	1.2	10	16.4
936020015	Gray	18	0.75	2.8	1.2	12	18.4
936020016	White	18	0.75	2.8	1.2	12	18.4
936020017	Red	N/A	1	3	1.4	6	12.3
936020018	Yellow	N/A	1	3	1.4	6	12.3
936020019	Red	N/A	1	3	1.4	8	14.3
936020020	Yellow	N/A	1	3	1.4	8	14.3
936020021	Red	N/A	1	3	1.4	10	16.3
936020022	Red	N/A	1	3	1.4	12	18.3
936020023	Yellow	N/A	1	3	1.4	12	18.3
936020024	Black	16	1.5	3.5	1.7	8	14.3
936020025	Red	16	1.5	3.5	1.7	8	14.3
936020026	Black	16	1.5	3.5	1.7	10	16.3
936020027	Red	16	1.5	3.5	1.7	10	16.3
936020028	Black	16	1.5	3.5	1.7	12	18.3
936020029	Black	16	1.5	3.5	1.7	18	24.3
936020030	Red	16	1.5	3.5	1.7	18	24.3

Ferrule	Color	AWG	mm2	Ø	d	P	L
936020031	Blue	14	2.5	4.2	2.3	8	15.4
936020032	Gray	14	2.5	4.2	2.3	8	15.4
936020033	Blue	14	2.5	4.2	2.3	12	19.4
936020034	Gray	14	2.5	4.2	2.3	12	19.4
936020035	Blue	14	2.5	4.2	2.3	18	25.4
936020036	Gray	14	2.5	4.2	2.3	18	25.4
936020037	Orange	12	4	4.8	2.8	10	17.4
936020038	Gray	12	4	4.8	2.8	10	17.4
936020039	Orange	12	4	4.8	2.8	12	19.4
936020040	Gray	12	4	4.8	2.8	12	19.4
936020041	Orange	12	4	4.8	2.8	18	25.4
936020042	Gray	12	4	4.8	2.8	18	25.4
936020043	Black	10	6	6.3	3.5	12	20.5
936020044	Yellow	10	6	6.3	3.5	12	20.5
936020045	Green	10	6	6.3	3.5	12	20.5
936020046	Black	10	6	6.3	3.5	18	26.5
936020047	Yellow	10	6	6.3	3.5	18	26.5
936020048	Green	10	6	6.3	3.5	18	26.5
936020049	Brown	8	10	7.8	4.5	12	20.8
936020050	Red	8	10	7.8	4.5	12	20.8
936020051	White	8	10	7.8	4.5	12	20.8
936020052	Brown	8	10	7.8	4.5	18	26.8
936020053	Red	8	10	7.8	4.5	18	26.8
936020054	White	8	10	7.8	4.5	18	26.8

Wire strip length = P + 2mm

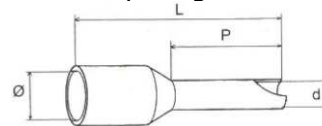

## CONDITIONS

After crimping, the ferrule meets a minimum pull force.

Wire Size		Pull Force Minimum	
AWG	mm <sup>2</sup>	N	Lb.
26	0.14	20	4.50
22	0.35	20	4.50
20	0.50	20	4.50
18	0.75	30	6.75
N/A	1.00	30	6.75

Wire Size		Pull Force Minimum	
AWG	mm <sup>2</sup>	N	Lb.
16	1.50	40	9.00
14	2.50	50	11.25
12	4.00	60	13.50
10	6.00	80	18.00
8	10.00	90	20.20

## OPERATION

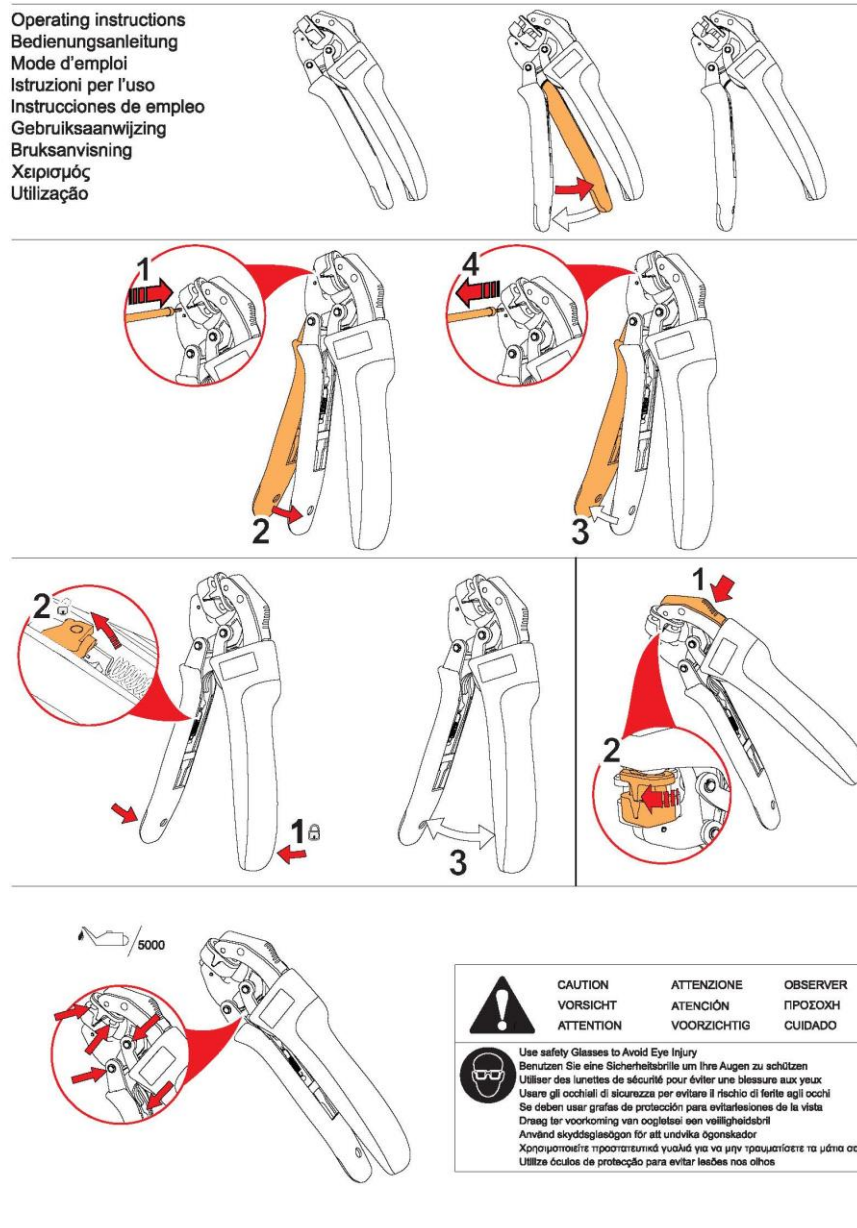

**Note:** The tamper-proof ratchet action will not release the tool until it has been fully closed.

## MAINTENANCE

---

It is recommended that each operator of the tool be made aware of and responsible for the following maintenance steps:

1. Remove dust, moisture and other contaminants with a clean brush or a soft, lint-free cloth.
2. Do not use any abrasive materials that could damage the tool.
3. Make certain all pins, pivot points and bearing surfaces are protected with a thin coat of high-quality machine oil. Do not oil excessively.
4. When the tool is not in use, keep the handles closed to prevent objects from becoming lodged in the crimping dies, and store the tool in a clean, dry area.

### Miscrimps or Jams

Should this tool ever become stuck or jammed in a partially closed position, **Do Not force the handles open or closed**. The tool will open easily by lifting the ratchet release lever. See Figure 2.

### Warranty

This tool is for electrical ferrule crimping purposes only. This tool is made of the best quality materials. All vital components are long life tested. All tools are warranted to be free of manufacturing defects for a period of 30 days. Should such a defect occur, Molex will repair or exchange the tool free of charge. This repair or exchange will not be applicable to altered, misused or damaged tools. This tool is designed for hand use only. Any clamping, fixturing or use of handle extensions voids this warranty.

**CAUTION: Repetitive use of this tool should be avoided.**

### CAUTIONS:

1. Manually powered hand tools are intended for low-volume use or field repair. This tool is **NOT** intended for production use. Repetitive use of this tool should be avoided.
2. Insulated rubber handles are not protection against electrical shock.
3. Wear eye protection at all times.
4. Use only ferrules specified for crimping with this tool.

## NOTES

---

1. This tool should only be used for the ferrules and wire gauges specified on this sheet.
2. This tool is intended for standard conductor sizes.
3. Molex does not repair hand tools (see warranty above). The replacement parts listed are the only parts available for repair. If the handles or crimp tooling are damaged or worn, a new tool must be purchased.
4. Molex does not certify crimp hand tools.

**PARTS LIST**

Item	Order Number	Description	Quantity
REF	200218-5000	Hand Crimp Tool	Figure 2
1	63810-0105	Ratchet Spring	1

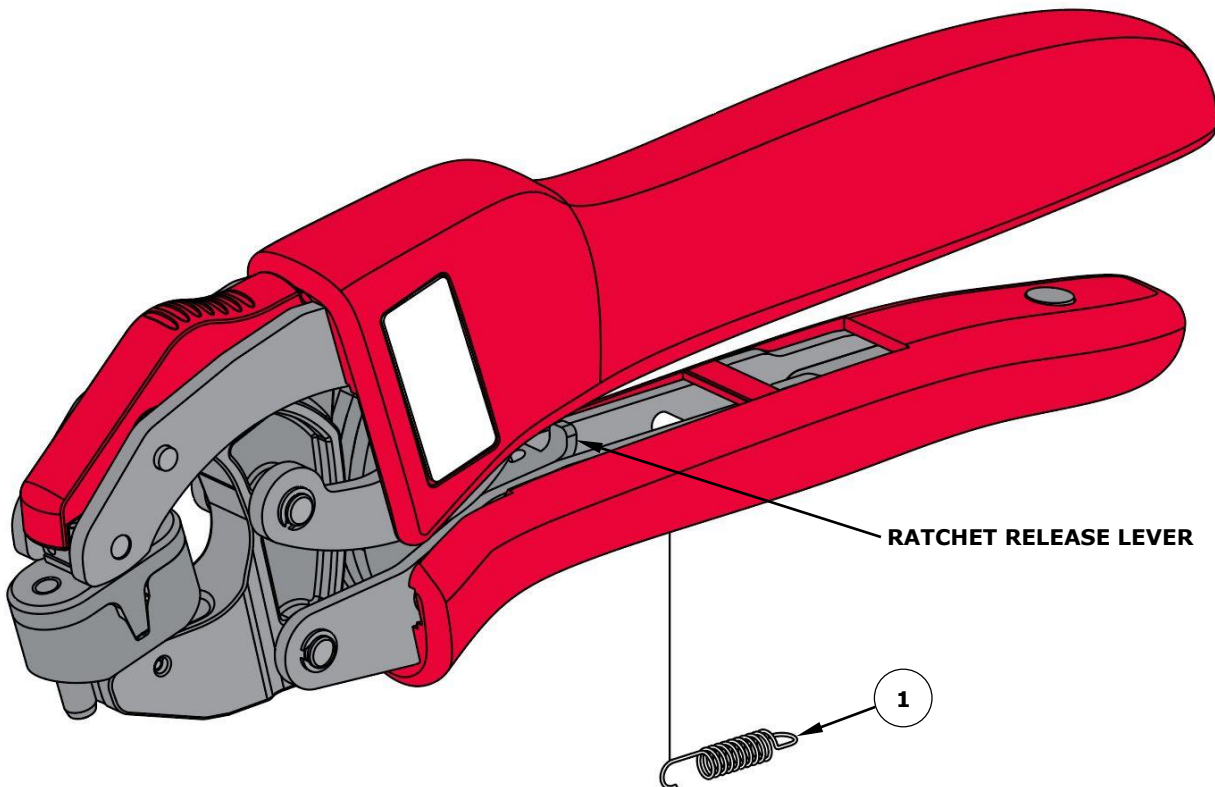

**Figure 2**

**Application Tooling Support**

**Phone:** (402) 458-TOOL (8665)  
**E-Mail:** [applicationtooling@molex.com](mailto:applicationtooling@molex.com)  
**Website:** [www.molex.com/applicationtooling](http://www.molex.com/applicationtooling)

Molex is a registered trademark of Molex, LLC in the United States of America and may be registered in other countries; all other trademarks listed herein belong to their respective owners.