

DIM.	TOL.
5mm DOWN	±0.2
5~20mm	±0.3
20~40mm	±0.4
40~60mm	±0.5
60~100mm	±0.8
100mm UP	±1.0

REVISIONS			
REV	DESCRIPTION	DATE	BY

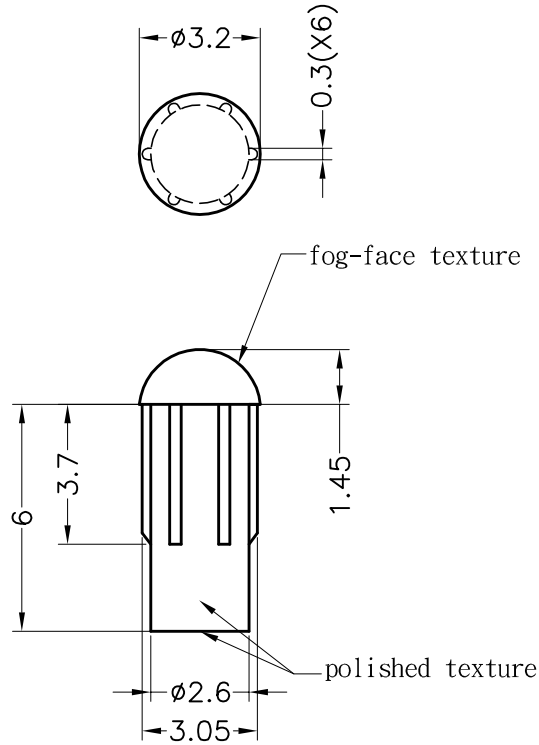

QMF22 Component - Plastics

Tuesday, June 08, 2004

E5007:

TEIJIN CHEMICALS LTD

HIBIYA DAIBIRU BLDG 2-2 UCHISAIWAI-CHO 1-CHOME CHIYODA-KU TOKYO 100-0011 JAPAN

Material Designation: **L-1225(#)(f2)**

Product Description: Polycarbonate (PC), designated "Panlite" furnished as pellets, powder.

Color	Min. Thick. (mm)	Flame Class	HWI	HAI	RTI Elec	RTI Imp	RTI Str	IEC GWIT	IEC GWI
ALL	0.4	V-2	4	3	80	80	80	-	-
	0.75	V-2	3	1	80	80	80	-	-
	1.5	V-2	3	1	125	115	125	-	-
	1.9	HB	3	1	125	115	125	-	-
	3	HB	2	1	125	115	125	-	-
	6	HB	1	1	125	115	125	-	-
CTI: 2		HVTR: 4			D495: 5				IEC Ball Pressure (C): -

Dielectric Strength (kV/mm): 30

Volume Resistivity (10¹⁰ ohm-cm): 16

Dimensional Stability (%): 0

ISO Tensile Strength (MPa): -

ISO Flexural Strength (MPa): -

ISO Heat Deflection (C): -

ISO Tensile Impact (kJ/m²): -

ISO Izod Impact (kJ/m²): -

ISO Charpy Impact (kJ/m²): -

(#)

Material designation may be suffixed with any one or two letters.

(f2)

Subjected to one or more of the following tests: Ultraviolet Light, Water Exposure or Immersion accordance with UL 746C, where the acceptability for outdoor use is to be determined by UL In



康揚企業股份有限公司

KANG YANG HARDWARE ENTERPRISE CO., LTD.

康揚塑膠(東莞)有限公司

KANG YANG PLASTIC(DONG GUAN) CO., LTD.

康哲電腦配件(吳江)有限公司

KANG CHE COMPUTER COMPONENTS(WUJIANG) CO., LTD.

PART NUMBER				DRAWING NUMBER		TITLE	
LEM-67		LEM-67		LIGHT PIPE		SPEC. DWG.	
MATERIAL				DATE		DRAWN	
PC UL94V-2				2009.02.02		JIM	
FINISH				CHECK		APPROVED	
CLEAR				UNLESS OTHERWISE SPECIFIED TOLERANCE		SEE ABOVE	
PART NUMBER		DRAWING NUMBER		COLOR		CHECK	
LEM-67		LEM-67		CLEAR		CHECK	
SIZE		SCALE		UNIT		REV	
A4		5:1		mm		A	