



A Product Line of  
Diodes Incorporated



## SPECIFICATION FOR APPROVAL

CUSTOMER \_\_\_\_\_

NOMINAL FREQUENCY 100.000000 MHz

HOLDER TYPE TYPE SQ 5.0x3.2 SEAM SEALED CRYSTAL CLOCK OSCILLATOR

SPEC. NO. ( P/N ) SQA000004Z

CUSTOMER P/N \_\_\_\_\_

ISSUE DATE August 26, 2018

VERSION C

APPROVED	PREPARED	QA

### Diodes Incorporated

No.2, Tzu-Chiang 5th Rd, Chung Li Industrial Park,  
Chung Li City, Taoyuan County, Taiwan (R.O.C.)  
TEL: 886-3-451-8888  
FAX: 886-3-461-3865  
<https://www.diodes.com>

\*RoHS Compliant  
\*HF-Halogen Free  
\*REACH Compliant



# TYPE SQ 5.0x3.2 SEAM SEALED CRYSTAL CLOCK OSCILLATOR

## SQA000004Z

VER. C 26-Aug-18

### ELECTRICAL SPECIFICATIONS

SRe Part Number : SQA000004Z

Item	Symbol	Specifications	Units	Notes
Nominal Frequency	F <sub>o</sub>	100.000000	MHz	
Frequency Stability	FT	± 50	ppm	**See note
Operating Temperature Range	TR	-40 to +85	°C	
Supply Voltage	V <sub>CC</sub>	+3.3 ± 10.0%	V	
Logic Type	LT	HCSL		
Supply Current, Output Enabled	I <sub>CC/OE</sub>	40	mA	Max.
Supply Current, Output Disabled	I <sub>CC/OD</sub>	30	uA	Max.
Duty Cycle (Symmetry)	DC/SY	45 / 55	%	Measured 50% of Waveform
Rise / Fall Time	T <sub>R</sub> /T <sub>F</sub>	0.5	ns	Max. measured from Vol=0.175V to Voh=0.525V
Output Voltage "0" Level	V <sub>OL</sub>	-0.150	V	Min.
Output Voltage "1" Level	V <sub>OH</sub>	0.900	V	Max.
Output Load		Rs=33Ω, Rp=50Ω, CL=2pF		Typ. In HCSL termination
Output Phase Jitter-PCIe Gen2		2.5	ps RMS	Max.
Output Phase Jitter-PCIe Gen3		1	ps RMS	Max.
Jitter, Phase	RMS	1	ps	Max. 12KHz ~ 20MHz Frequency Band
Jitter, Accumulated	RMS(1-σ)	4	ps	Typ. 20,000 Consecutive Periods
Jitter, Peak to Peak	Pk-Pk	40	ps	Max. 100,000 Random Periods
Start Up Time		10	ms	Max.
Storage Temperature Range		-55 to +125	°C	

※ This product doesn't include harmful substance that stipulated by SONY SS-00259 Level 1 and S-AT2-001 Level 1 standard. RoHS Compliant (Pb - Free).

\*\*Stability includes all combinations of Operating Temperature, Load changes, rated Input (Supply) Voltage changes, Initial Calibration Tolerance (25°C), Aging (5 years at 40°C Average Effective Ambient Temperature), Shock and Vibration.

#### OUTPUT ENABLE / DISABLE

Parameter	Min.	Typ.	Max.	Units	Notes
Input Voltage (Pin1), Output Enable	0.7V <sub>DD</sub>			V	Or Open
Input Voltage (Pin1), Output Disable (low power standby)			0.3V <sub>DD</sub>	V	Output is Hi-Z
Output Disable Delay			200	ns	
Output Enable Delay			2	ms	



# TYPE SQ 5.0x3.2 SEAM SEALED CRYSTAL CLOCK OSCILLATOR

## SQA000004Z

VER. C 26-Aug-18

### TEST CIRCUIT

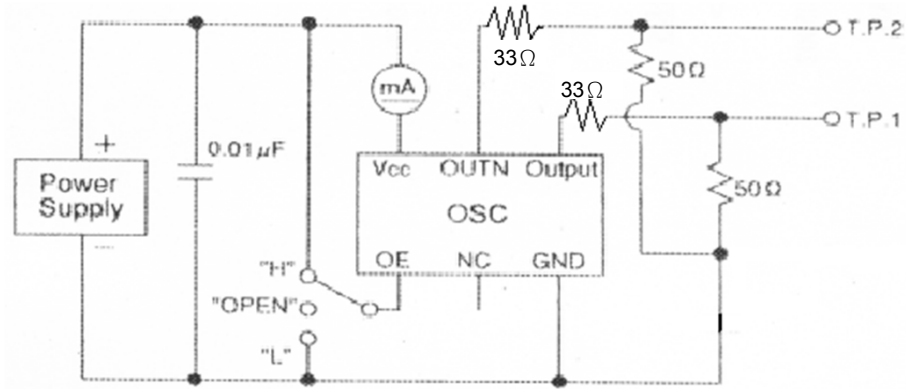

### OUTPUT WAVEFORM

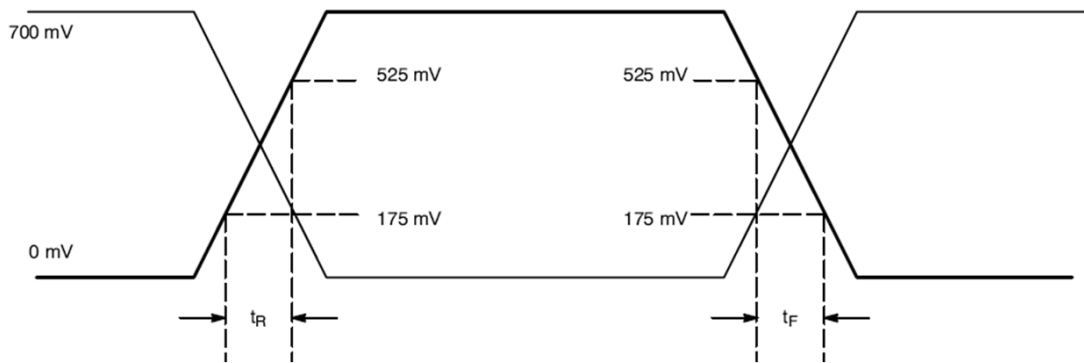

# TYPE SQ 5.0x3.2 SEAM SEALED CRYSTAL CLOCK OSCILLATOR

## SQA000004Z

VER. C 26-Aug-18

### RELIABILITY SPECIFICATIONS

#### ENVIRONMENTAL:

- a) THERMAL SHOCK: MIL-STD-883, Method 1011, Condition A
- b) MOISTURE RESISTANCE: MIL-STD-883, Method 1004
- c) VIBRATION: MIL-STD-883, Method 2007, Condition A
- d) RESISTANCE TO SOLDERING HEAT: J-STD-020D Table 5-2 Pb-free devices  
(except 2 cycles max)
- e) HAZARDOUS SUBSTANCE: RoHS Compliant

#### MECHANICAL:

- a) SHOCK: MIL-STD-883, Method 2002, Condition B
- b) SOLDERABILITY: JESD22-B102-D Method 2 (Preconditioning E)
- c) TERMINAL STRENGTH: MIL-STD-883, Method 2004, Test Condition D
- d) GROSS LEAK: MIL-STD-883, Method 1014, Condition C
- e) FINE LEAK: MIL-STD-883, Method 1014, Condition A2,  $R1=2 \times 10^{-8}$  atm cc/s
- f) SOLVENT RESISTANCE: MIL-STD-202, Method 215

### SUGGESTED IR REFLOW PROFILE

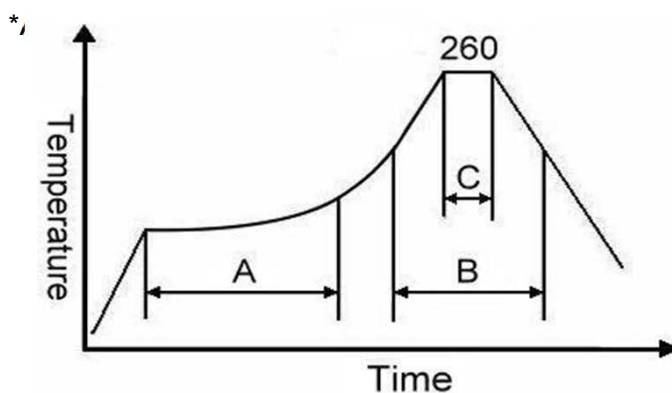

Note:

	Stage	Temperature	Time
A	Preheat	150~200°C	60~120 Sec
B	Primary Heat	217°C	60~150 Sec
C	Peak	260°C	10 Sec

# TYPE SQ 5.0x3.2 SEAM SEALED CRYSTAL CLOCK OSCILLATOR

## SQA000004Z

VER. C 26-Aug-18

### MARKING

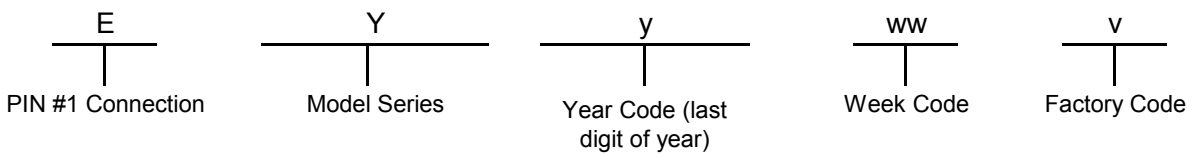
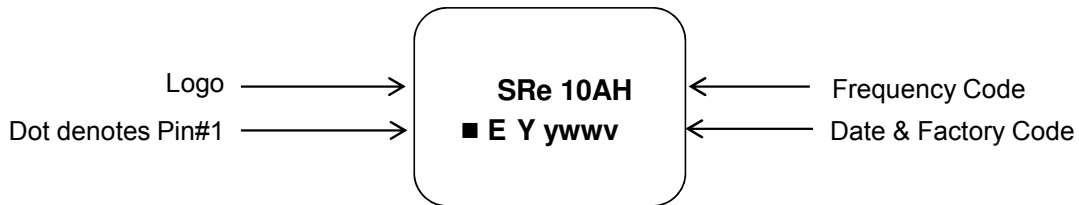

### MECHANICAL DRAWINGS ( Scale:None. Dimensions are in mm.)

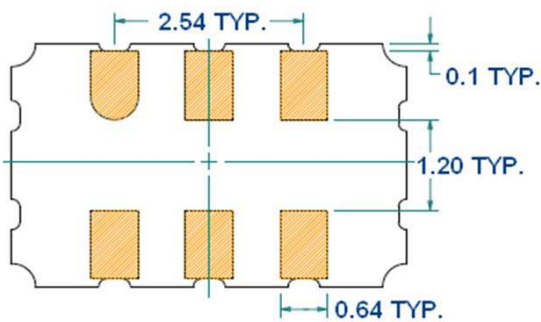
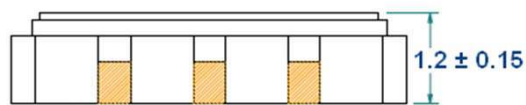
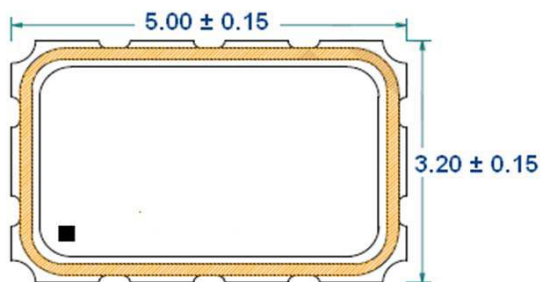

#### Recommended Land Pattern\*

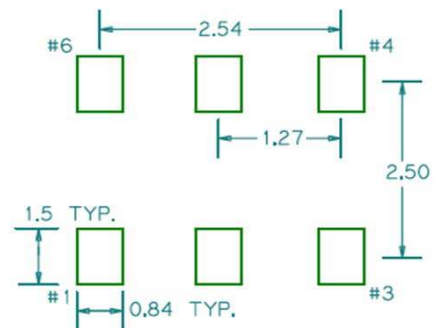

\*External high-frequency power decoupling is recommended. (see test circuit for minimum recommendation). To ensure optimal performance, do not route traces beneath the package.

Pin	Function
1	OE
2	NC
3	V <sub>EE</sub>
4	OUTPUT
5	OUTPUT N
6	V <sub>CC</sub>

# TYPE SQ 5.0x3.2 SEAM SEALED CRYSTAL CLOCK OSCILLATOR

## SQA000004Z

VER. C 26-Aug-18

### TAPE&REEL

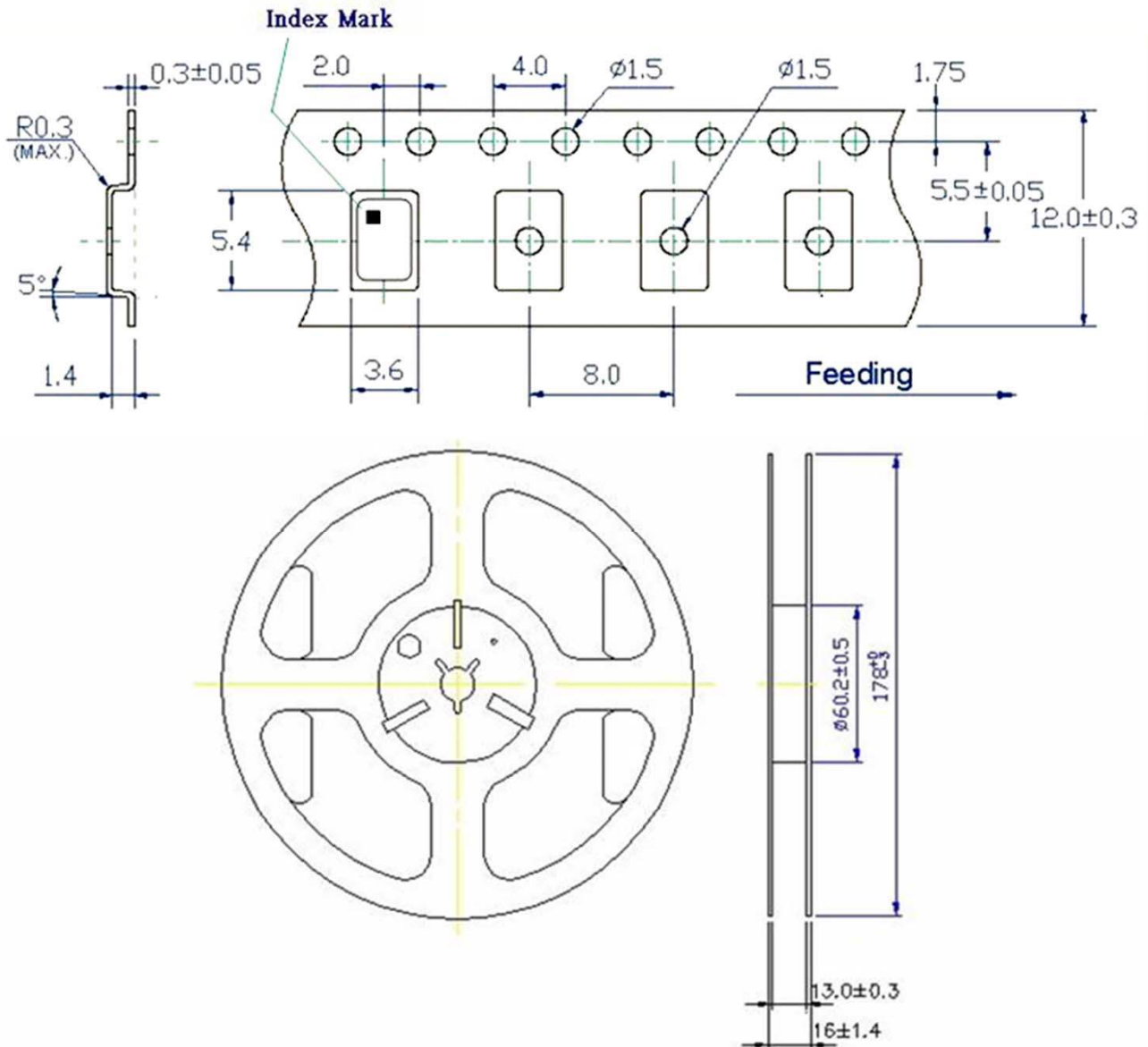

1. 230mm minimum leader which consist of carrier and/or tape followed by a minimum of 160mm of empty carrier tape sealed with cover tape.
2. 160mm minimum trailer of empty carrier tape sealed with cover tape.

# TYPE SQ 5.0x3.2 SEAM SEALED CRYSTAL CLOCK OSCILLATOR

## SQA000004Z

VER. C 26-Aug-18

### PACKING

