

ML401/ML402/ML403 Evaluation Platform

User Guide

UG080 (v2.5) May 24, 2006





Xilinx is disclosing this Document and Intellectual Property (hereinafter “the Design”) to you for use in the development of designs to operate on, or interface with Xilinx FPGAs. Except as stated herein, none of the Design may be copied, reproduced, distributed, republished, downloaded, displayed, posted, or transmitted in any form or by any means including, but not limited to, electronic, mechanical, photocopying, recording, or otherwise, without the prior written consent of Xilinx. Any unauthorized use of the Design may violate copyright laws, trademark laws, the laws of privacy and publicity, and communications regulations and statutes.

Xilinx does not assume any liability arising out of the application or use of the Design; nor does Xilinx convey any license under its patents, copyrights, or any rights of others. You are responsible for obtaining any rights you may require for your use or implementation of the Design. Xilinx reserves the right to make changes, at any time, to the Design as deemed desirable in the sole discretion of Xilinx. Xilinx assumes no obligation to correct any errors contained herein or to advise you of any correction if such be made. Xilinx will not assume any liability for the accuracy or correctness of any engineering or technical support or assistance provided to you in connection with the Design.

THE DESIGN IS PROVIDED “AS IS” WITH ALL FAULTS, AND THE ENTIRE RISK AS TO ITS FUNCTION AND IMPLEMENTATION IS WITH YOU. YOU ACKNOWLEDGE AND AGREE THAT YOU HAVE NOT RELIED ON ANY ORAL OR WRITTEN INFORMATION OR ADVICE, WHETHER GIVEN BY XILINX, OR ITS AGENTS OR EMPLOYEES. XILINX MAKES NO OTHER WARRANTIES, WHETHER EXPRESS, IMPLIED, OR STATUTORY, REGARDING THE DESIGN, INCLUDING ANY WARRANTIES OF MERCHANTABILITY, FITNESS FOR A PARTICULAR PURPOSE, TITLE, AND NONINFRINGEMENT OF THIRD-PARTY RIGHTS.

IN NO EVENT WILL XILINX BE LIABLE FOR ANY CONSEQUENTIAL, INDIRECT, EXEMPLARY, SPECIAL, OR INCIDENTAL DAMAGES, INCLUDING ANY LOST DATA AND LOST PROFITS, ARISING FROM OR RELATING TO YOUR USE OF THE DESIGN, EVEN IF YOU HAVE BEEN ADVISED OF THE POSSIBILITY OF SUCH DAMAGES. THE TOTAL CUMULATIVE LIABILITY OF XILINX IN CONNECTION WITH YOUR USE OF THE DESIGN, WHETHER IN CONTRACT OR TORT OR OTHERWISE, WILL IN NO EVENT EXCEED THE AMOUNT OF FEES PAID BY YOU TO XILINX HEREUNDER FOR USE OF THE DESIGN. YOU ACKNOWLEDGE THAT THE FEES, IF ANY, REFLECT THE ALLOCATION OF RISK SET FORTH IN THIS AGREEMENT AND THAT XILINX WOULD NOT MAKE AVAILABLE THE DESIGN TO YOU WITHOUT THESE LIMITATIONS OF LIABILITY.

The Design is not designed or intended for use in the development of on-line control equipment in hazardous environments requiring fail-safe controls, such as in the operation of nuclear facilities, aircraft navigation or communications systems, air traffic control, life support, or weapons systems (“High-Risk Applications”). Xilinx specifically disclaims any express or implied warranties of fitness for such High-Risk Applications. You represent that use of the Design in such High-Risk Applications is fully at your risk.

© 2002-2006 Xilinx, Inc. All rights reserved. XILINX, the Xilinx logo, and other designated brands included herein are trademarks of Xilinx, Inc. PowerPC is a trademark of IBM, Inc. All other trademarks are the property of their respective owners.

Revision History

The following table shows the revision history for this document.

Date	Version	Revision
09/24/04	1.0	Initial Xilinx release.
10/20/04	1.0.1	Minor edits to text and figures.
02/17/05	1.1	Minor edits: <ul style="list-style-type: none">• Figure 1 and Figure 4: Corrected the regulator number for the 6A SWIFT part that goes to 1.2V. Removed digital supply reference.• Table 6: Corrected the GPIO LED 3 (DS6) FPGA pin number.
02/28/05	2.0	Renamed title from <i>ML401 Evaluation Platform</i> user guide to <i>ML40x Evaluation Platform</i> user guide. Expanded document from ML401-specific to include ML401, ML402, and ML403 platforms. Minor edits to text and figures.

Date	Version	Revision
10/25/05	2.1	Renamed title from <i>ML40x Evaluation Platform</i> user guide to <i>ML401/ML402/ML403 Evaluation Platform</i> user guide. Technical edits: <ul style="list-style-type: none"> • Features section: Expanded VGA output bullet items. • 15. VGA Output section: Added Table 13 for the Video DAC connections. Minor edits to text for clarity.
11/15/05	2.2	Clarified ZBT synchronous RAM size in Features section.
01/13/06	2.3	Minor edits: <ul style="list-style-type: none"> • Deleted "P/N 0402337" (obsolete) from document's identification. • Deleted power cord reference from Power supply bullet in Package Contents section. • Typographical corrections.
05/07/06	2.4	Updated USB interface chip criteria in Features section.
05/24/06	2.5	Updated USB interface chip criteria in Features section. Updated 18. ZBT Synchronous SRAM section.

Table of Contents

Preface: About This Guide

Guide Contents	7
Additional Resources	7
Conventions	7
Typographical	7
Online Document	8

ML401/ML402/ML403 Evaluation Platform

Introduction	9
Features	9
Package Contents	10
Additional Information	10
Block Diagram	11
Detailed Description	12
1. Virtex-4 FPGA	14
2. DDR SDRAM	16
3. Differential Clock Input And Output With SMA Connectors	16
4. Oscillator Sockets	17
5. LCD Brightness and Contrast Adjustment	17
6. DIP Switches (Active-High)	17
7. User and Error LEDs (Active-High)	18
8. User Push Buttons (Active-High)	19
9. CPU Reset Button (Active-Low)	19
10. Expansion Headers	20
11. Stereo AC97 Audio Codec	24
12. RS-232 Serial Port	24
13. 16-Character x 2-Line LCD	24
14. IIC Bus with 4-Kb EEPROM	25
15. VGA Output	25
16. PS/2 Mouse and Keyboard Ports	25
17. System ACE and CompactFlash Connector	26
18. ZBT Synchronous SRAM	26
19. Linear Flash Chips	27
20. Xilinx XC95144XL CPLD	27
21. 10/100/1000 Tri-Speed Ethernet PHY	27
22. USB Controller with Host and Peripheral Ports	28
23. Xilinx XCF32P Platform Flash Configuration Storage Device	28
24. JTAG Configuration Port	28
25. Onboard Power Supplies	29
26. AC Adapter and Input Power Switch/Jack	29
27. Power Indicator LED	29
28. INIT LED	29
29. DONE LED	30

30. Program Switch	30
31. Configuration Address and Mode DIP Switches	30
32. Encryption Key Battery	30
33. Configuration Source Selector Switch	30
Configuration Options	31
JTAG (Parallel Cable IV Cable and System ACE Controller)	31
Platform Flash Memory	32
Linear Flash + CPLD	32

About This Guide

The ML401/ML402/ML403 evaluation platforms enable designers to investigate and experiment with features of the Virtex™-4 family of FPGAs. This user guide describes features and operation of the ML401, ML402, and ML403 (ML40x) evaluation platforms.

Guide Contents

This manual contains the following chapter: “[ML401/ML402/ML403 Evaluation Platform](#).”

Additional Resources

To find additional documentation, see the Xilinx website at:

<http://www.xilinx.com/literature/index.htm>.

To search the Answer Database of silicon, software, and IP questions and answers, or to create a technical support WebCase, see the Xilinx website at:

<http://www.xilinx.com/support>.

Conventions

This document uses the following conventions. An example illustrates each convention.

Typographical

The following typographical conventions are used in this document:

Convention	Meaning or Use	Example
Courier font	Messages, prompts, and program files that the system displays	<code>speed grade: - 100</code>
Courier bold	Literal commands that you enter in a syntactical statement	ngdbuild <i>design_name</i>
Helvetica bold	Commands that you select from a menu	File → Open
	Keyboard shortcuts	Ctrl+C

Convention	Meaning or Use	Example
Italic font	Variables in a syntax statement for which you must supply values	<code>ngdbuild design_name</code>
	References to other manuals	See the <i>Development System Reference Guide</i> for more information.
	Emphasis in text	If a wire is drawn so that it overlaps the pin of a symbol, the two nets are <i>not</i> connected.
Square brackets []	An optional entry or parameter. However, in bus specifications, such as <code>bus [7:0]</code> , they are required.	<code>ngdbuild [option_name] design_name</code>
Braces { }	A list of items from which you must choose one or more	<code>lowpwr = {on off}</code>
Vertical bar	Separates items in a list of choices	<code>lowpwr = {on off}</code>
Vertical ellipsis .	Repetitive material that has been omitted	IOB #1: Name = QOUT' IOB #2: Name = CLKIN' . . .
Horizontal ellipsis ...	Repetitive material that has been omitted	<code>allow block block_name loc1 loc2 ... locn;</code>

Online Document

The following conventions are used in this document:

Convention	Meaning or Use	Example
Blue text	Cross-reference link to a location in the current document	See the section “ Additional Resources ” for details. Refer to “ Title Formats ” in Chapter 1 for details.
Red text	Cross-reference link to a location in another document	See Figure 2-5 in the <i>Virtex-II Handbook</i> .
Blue, underlined text	Hyperlink to a website (URL)	Go to http://www.xilinx.com for the latest speed files.

ML401/ML402/ML403 Evaluation Platform

Introduction

The ML401/ML402/ML403 evaluation platform enables designers to investigate and experiment with features of the Virtex™-4 family of FPGAs. This user guide describes features and operation of the ML401, ML402, and ML403 (ML40x) evaluation platforms.

Features

- Virtex-4 FPGA:
 - ◆ ML401: XC4VLX25-FF668-10
 - ◆ ML402: XC4VSX35-FF668-10
 - ◆ ML403: XC4VFX12-FF668-10
- 64-MB DDR SDRAM, 32-bit interface running up to 266-MHz data rate
- One differential clock input pair and differential clock output pair with SMA connectors
- One 100-MHz clock oscillator (socketed) plus one extra open 3.3V clock oscillator socket
- General purpose DIP switches (ML401/ML402 platform), LEDs, and push buttons
- Expansion header with 32 single-ended I/O, 16 LVDS capable differential pairs, 14 spare I/Os shared with buttons and LEDs, power, JTAG chain expansion capability, and IIC bus expansion
- Stereo AC97 audio codec with line-in, line-out, 50-mW headphone, and microphone-in (mono) jacks
- RS-232 serial port
- 16-character x 2-line LCD display
- One 4-Kb IIC EEPROM
- VGA output:
 - ◆ ML401: 50 MHz / 24-bit video DAC
 - ◆ ML402: 140 MHz / 24-bit video DAC
 - ◆ ML403: 140 MHz / 15-bit video DAC
- PS/2 mouse and keyboard connectors
- System ACE™ CompactFlash configuration controller with Type I/II CompactFlash connector

- ZBT synchronous SRAM
 - ◆ ML401/ML402: 9 Mb on 32-bit data bus with four parity bits
 - ◆ ML403: 8 Mb on 32-bit data bus with no parity bits
- Intel StrataFlash (or compatible) linear flash chips (8 MB)
- 10/100/1000 tri-speed Ethernet PHY transceiver
- USB interface chip (Cypress CY7C67300) with host and peripheral ports
- Xilinx XC95144XL CPLD to allow linear flash chips to be used for FPGA configuration
- Xilinx XCF32P Platform Flash configuration storage device
- JTAG configuration port for use with Parallel Cable III or Parallel Cable IV cable
- Onboard power supplies for all necessary voltages
- 5V @ 3A AC adapter
- Power indicator LED

Package Contents

- Xilinx Virtex-4 ML40x evaluation platform
- System ACE CompactFlash card
- Power supply
- Carrying case with anti-static foam
- Printed documentation

Additional Information

For current information about your ML40x evaluation platform, visit the corresponding Web page:

- ML401: <http://www.xilinx.com/ml401>
- ML402: <http://www.xilinx.com/ml402>
- ML403: <http://www.xilinx.com/ml403>

The information includes:

- Current version of this user guide in PDF format
- Example design files for demonstration of Virtex-4 features and technology
- Demonstration hardware and software configuration files for the System ACE controller, Platform Flash configuration storage device, CPLD, and linear flash chips
- MicroBlaze™ and PowerPC™ 405 (ML403) EDK reference design files
- Full schematics in PDF format and ViewDraw schematic format
- PC board layout in Pads PCB format
- Gerber files in *.pho and *.pdf for the PC board (There are many free or shareware Gerber file viewers available on the internet for viewing and printing these files)
- Additional documentation, errata, frequently asked questions, and the latest news

For information about the Virtex-4 family of FPGA devices, including product highlights, data sheets, user guides, and application notes, see the Virtex-4 website at <http://www.xilinx.com/virtex4>. Additional information is available from the data sheets and application notes from the component manufacturers.

Block Diagram

Figure 1 shows a block diagram of the ML40x evaluation platform (board).

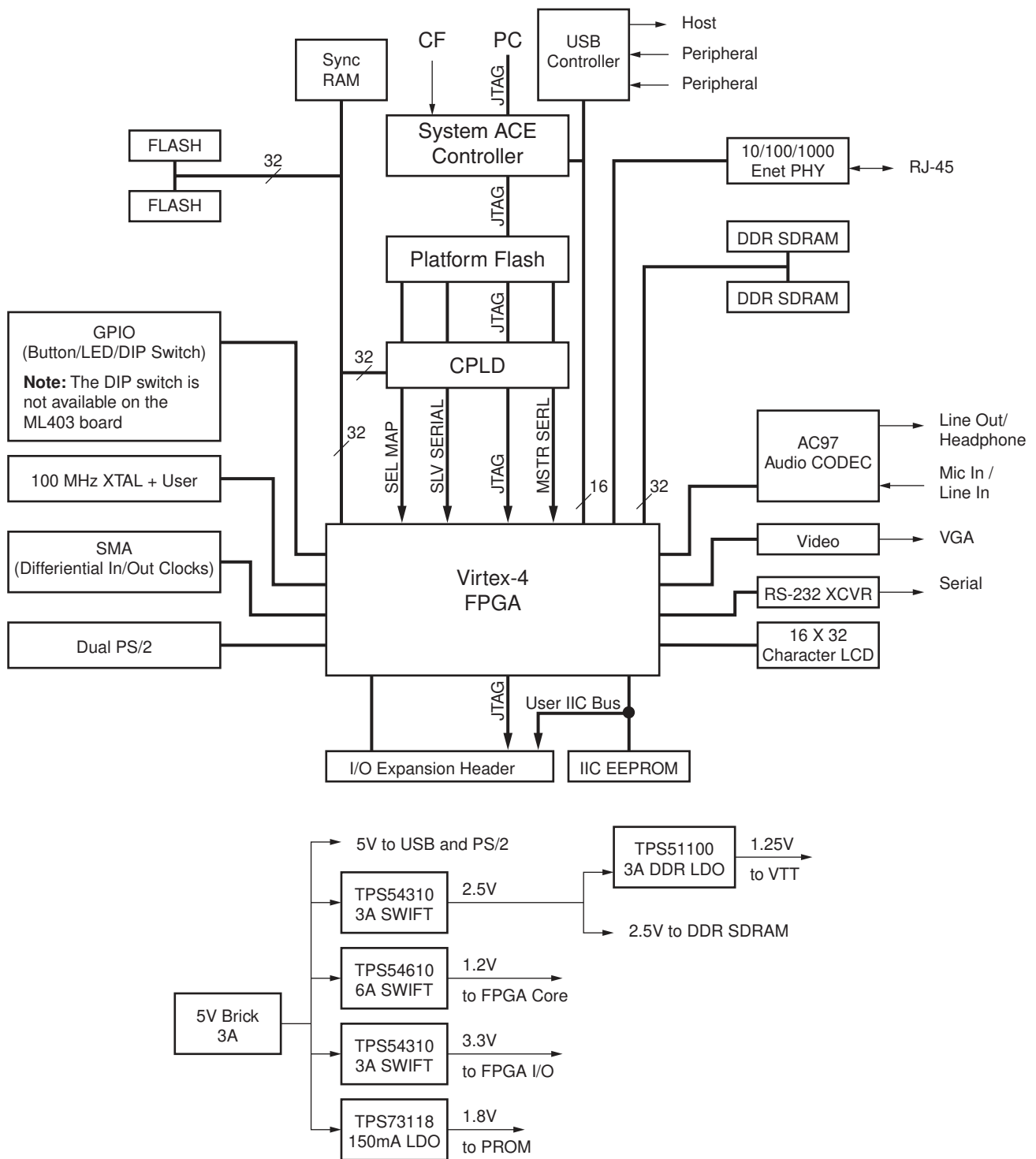

UG080_01_050506

Figure 1: Virtex-4 ML40x Evaluation Platform Block Diagram

Detailed Description

The ML40x evaluation platform (board) is shown in [Figure 2](#) (front) and [Figure 3](#), page 13 (back). The numbered sections on the pages following the figures contain details on each feature.

Note: The ML402 and ML403 boards might differ slightly from the board shown.

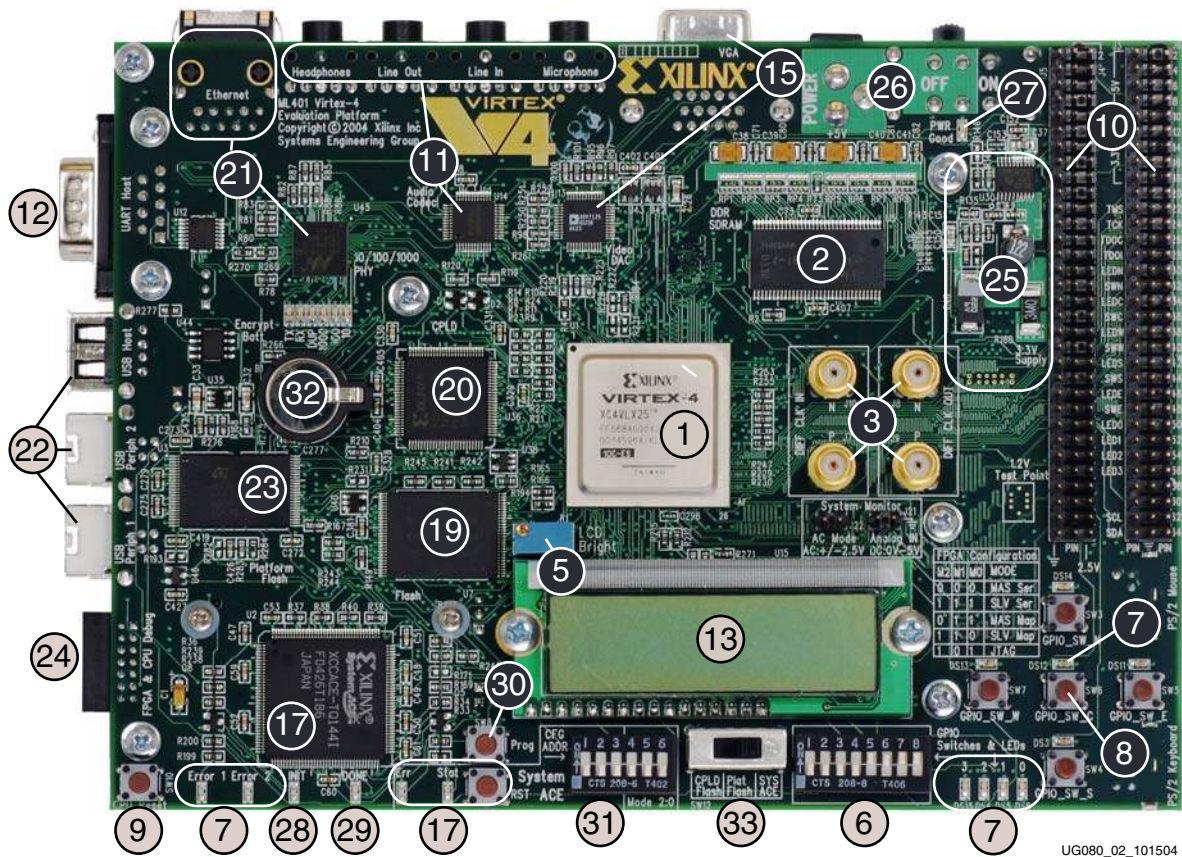
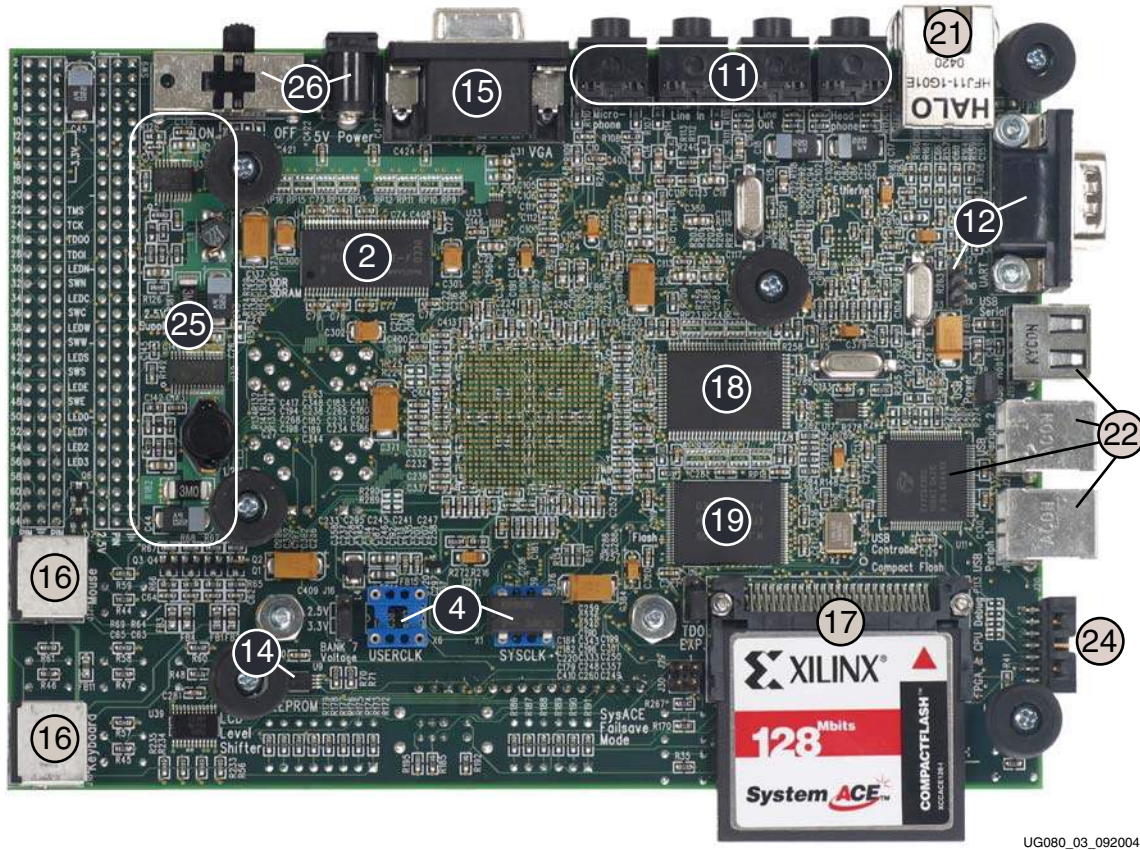

Figure 2: Detailed Description of Virtex-4 ML40x Evaluation Platform Components (Front)

Note: The label on the CompactFlash (CF) card shipped with your board might differ slightly from the one shown.



UG080_03_092004

Figure 3: Detailed Description of Virtex-4 ML40x Evaluation Platform Components (Back)

1. Virtex-4 FPGA

A Xilinx Virtex-4 FPGA is installed on the evaluation platform (the board):

- ◆ ML401: XC4VLX25-FF668-10
- ◆ ML402: XC4VSX35-FF668-10
- ◆ ML403: XC4VFX12-FF668-10

Configuration

The board supports configuration in all modes: JTAG, Master Serial, Slave Serial, Master SelectMAP, and Slave SelectMAP modes. See the “[Configuration Options](#),” page 31 section for more information.

I/O Voltage Rails

The FPGA has 11 banks of which only the first 10 banks are used. The last bank is powered but unused. The I/O voltage applied to each bank is summarized in [Table 1](#).

Table 1: I/O Voltage Rail of FPGA Banks

FPGA Bank	I/O Voltage Rail
0	3.3V
1	3.3V
2	3.3V
3	2.5V
4	3.3V
5	2.5V
6	2.5V
7	User selectable as 2.5V or 3.3V using jumper J16
8	3.3V
9 ^a	3.3V
10 ^a	3.3V (Powered but I/O pins are not used)

a. Bank 9 and 10 are non-connected pins in the case of the ML403 with XC4VFX12-FF668.

Digitally Controlled Impedance (DCI)

Some FPGA banks can support the DCI feature in Virtex-4 FPGAs. Support for DCI is summarized in [Table 2](#).

Table 2: DCI Capability of FPGA Bank

FPGA Bank	DCI Capability
1	Not supported.
2	Not supported.
3	Optional: User must remove resistors R234 and R235 and must install resistors R222 and R221. Note: Use of DCI will disable the use of GPIO LED [2] and [3].
4	Not supported.
5	Optional: User must install resistors R224 and R225 to use DCI. In bitgen, the switch "-g DCIUpdateMode:Quiet" must also be used. Note: Use of DCI will disable user control of the DDR_CS_N and DDR_CKE signals.
6	Not supported.
7	Optional: User must install resistors R289 and R290. Note: This will disable the use of two I/O pins on the expansion connector J5 (pin 38 and 40).
8	Yes, 49.9Ω resistors are installed.
9 ^a	Yes, 49.9Ω resistors are installed.
10 ^a	Not supported.

a. Bank 9 and 10 are non-connected pins in the case of the ML403 board with XC4VFX12-FF668.

2. DDR SDRAM

The board contains 64 MB of DDR SDRAM using two Infineon HYB25D256160BT-7 (or compatible) chips (U4 and U5). Each chip is 16 bits wide and together form a 32-bit data bus capable of running up to 266 MHz. All DDR SDRAM signals are terminated through 47Ω resistors to a 1.25V VTT reference voltage. The board is designed for matched length traces across all DDR control and data signals except clocks and the DDR Loop trace (see “DDR Clock Signal” and “DDR Loop Signal”).

The board can support up to 256 MB of total DDR SDRAM memory if larger chips are installed. An extra address pin is present on the board to support up to 1-Gb DDR chips.

DDR Clock Signal

The DDR clock signal is broadcast from the FPGA as a single differential pair that drives both DDR chips. The delay on the clock trace is designed to match the delay of the other DDR control and data signals. The DDR clock is also fed back to the FPGA to allow for clock deskew using Virtex-4 DCMs. The board is designed so that the DDR clock signal reaches the FPGA clock feedback pin at the same time as it arrives at the DDR chips.

DDR Loop Signal

The DDR loop signal is a trace driven and then received back at the FPGA with a delay equal to the sum of the trace delays of the clock and DQS signals. This looped trace can be used in high-speed memory controllers to help compensate for the physical trace delays between the FPGA and DDR chips.

3. Differential Clock Input And Output With SMA Connectors

High-precision clock signals can be input to the FPGA using differential clock signals brought in through 50Ω SMA connectors. This allows an external function generator or other clock source to drive the differential clock inputs that directly feed the global clock input pins of the FPGA. The FPGA can be configured to present a 100Ω termination impedance.

A differential clock output from the FPGA is driven out through a second pair of SMA connectors. This allows the FPGA to drive a precision clock to an external device such as a piece of test equipment. [Table 3](#) summarizes the differential SMA clock pin connections.

Table 3: Differential SMA Clock Connections

Label	Clock Name	FPGA Pin
J10	SMA_DIFF_CLK_IN_N	C12
J7	SMA_DIFF_CLK_IN_P	C13
J8	SMA_DIFF_CLK_OUT_N	D7
J9	SMA_DIFF_CLK_OUT_P	D8

4. Oscillator Sockets

The ML40x evaluation platform has two crystal oscillator sockets, each wired for standard LVTTTL-type oscillators. (A 100-MHz oscillator is pre-installed in the X1 SYSCLK socket.) These connect to the FPGA clock pins as shown in [Table 4](#). The oscillator sockets accept half-sized oscillators and are powered by the 3.3V supply.

Table 4: Oscillator Socket Connections

Label	Clock Name	FPGA Pin
X1	SYSCLK	AE14
X6	USERCLK	AD12

5. LCD Brightness and Contrast Adjustment

Turning potentiometer R1 adjusts the image contrast of the character LCD.

6. DIP Switches (Active-High)

Eight general purpose (active-High) DIP switches are connected to the user I/O pins of the FPGA. [Table 5](#) summarizes these connections.

Note: On the ML403 board, these DIP switches are not installed.

Table 5: DIP Switches Connections (SW1)

SW1	FPGA Pin
1	R20
2	R19
3	T26
4	U26
5	U23
6	V23
7	U25
8	U24

7. User and Error LEDs (Active-High)

There are a total of 11* active-High LEDs directly controllable by the FPGA:

- Four green LEDs are general purpose LEDs arranged in a row
- Five green LEDs are positioned next to the North-East-South-West-Center oriented push buttons (only the *center* one is cited in [Figure 2, page 12](#))
- Two* red LEDs are intended to be used for signaling error conditions, such as bus errors, but can be used for any other purpose

Note: *On the ML403 board, the Error 2 LED is not installed.

[Table 6](#) summarizes the LED definitions and connections.

Table 6: User and Error LED Connections

Reference Designator	Label/Definition	Color	FPGA Pin
DS14	LED North	Green	E2
DS11	LED East	Green	E10
DS3	LED South	Green	A5
DS13	LED West	Green	F9
DS12	LED Center	Green	C6
DS15	GPIO LED 0	Green	G5
DS4	GPIO LED 1	Green	G6
DS5	GPIO LED 2	Green	A11
DS6	GPIO LED 3	Green	A12
DS205	Error 1	Red	V6
DS206*	Error 2	Red	L24

Note: *On the ML403 board, the Error 2 LED is not installed.

8. User Push Buttons (Active-High)

Five active-High user push buttons are available for general purpose usage and are arranged in a North-East-South-West-Center orientation (only the *center* one is cited in [Figure 2, page 12](#)). [Table 7](#) summarizes the user push button connections.

Table 7: User Push Button Connections

Reference Designator	Label/Definition	FPGA Pin
SW3	GPIO Switch North	E7
SW5	GPIO Switch East	F10
SW4	GPIO Switch South	A6
SW7	GPIO Switch West	E9
SW6	GPIO Switch Center	B6

9. CPU Reset Button (Active-Low)

The CPU reset button is an active-Low push button intended to be used as a system or user reset button. This button is wired only to an FPGA I/O pin, so it can also be used as a general purpose button (see [Table 8](#)).

Table 8: CPU Reset Connections

Reference Designator	Label/Definition	FPGA Pin
SW10	FPGA CPU RESET	D6

10. Expansion Headers

The board contains expansion headers for easy expansion or adaptation of the board for other applications. The expansion connectors use standard 0.1-inch headers. The expansion connectors contain connections to single-ended and differential FPGA I/Os, ground, 2.5V/3.3V/5V power, JTAG chain, and the IIC bus.

Differential Expansion I/O Connectors

Header J5 contains 16 pairs of differential signal connections to the FPGA I/Os. This permits the signals on this connector to carry high-speed differential signals such as LVDS data. All differential signals are routed with 100Ω differential trace impedance. Matched length traces are used across all differential signals; consequently, these signals connect to the FPGA I/O and can also be used as independent single-ended nets. The V_{CCIO} of these signals can be set to 2.5V or 3.3V by setting jumper J16. [Table 9](#) summarizes the differential connections on this expansion I/O connector.

Table 9: Expansion I/O Differential Connections (J5)

Header Pin (Diff Pair Pos)	Header Pin (Diff Pair Neg)	Label (Diff Pair Pos)	Label (Diff Pair Neg)	FPGA Pin (Diff Pair Pos)	FPGA Pin (Diff Pair Neg)
J5, Pin 4	J5, Pin 2	HDR2_4	HDR2_2	AA18	Y18
J5, Pin 8	J5, Pin 6	HDR2_28	HDR2_26	Y19	W19
J5, Pin 12	J5, Pin 10	HDR2_20	HDR2_18	Y20	Y21
J5, Pin 16	J5, Pin 14	HDR2_12	HDR2_10	W23	W24
J5, Pin 20	J5, Pin 18	HDR2_8	HDR2_6	Y22	Y23
J5, Pin 24	J5, Pin 22	HDR2_60	HDR2_58	AA19	AA20
J5, Pin 28	J5, Pin 26	HDR2_56	HDR2_54	Y17	AA17
J5, Pin 32	J5, Pin 30	HDR2_52	HDR2_50	AB20	AC20
J5, Pin 36	J5, Pin 34	HDR2_36	HDR2_34	AE21	AD21
J5, Pin 40	J5, Pin 38	HDR2_16	HDR2_14	AE20	AD20
J5, Pin 44	J5, Pin 42	HDR2_64	HDR2_62	AD19	AC19
J5, Pin 48	J5, Pin 46	HDR2_48	HDR2_46	AC18	AB18
J5, Pin 52	J5, Pin 50	HDR2_24	HDR2_22	AF23	AE23
J5, Pin 56	J5, Pin 54	HDR2_44	HDR2_42	AF21	AF22
J5, Pin 60	J5, Pin 58	HDR2_32	HDR2_30	AF19	AF20
J5, Pin 64	J5, Pin 62	HDR2_40	HDR2_38	AF18	AE18

Single-Ended Expansion I/O Connectors

Header J6 contains 32 single-ended signal connections to the FPGA I/Os. This permits the signals on this connector to carry high-speed single-ended data. All single-ended signals on connector J6 are matched length traces. The V_{CCIO} of these signals can be set to 2.5V or 3.3V by setting jumper J16. [Table 10](#) (spans onto next page) summarizes the single-ended connections on this expansion I/O connector.

Table 10: Expansion I/O Single-Ended Connections (J6)

Header Pin	Label	FPGA Pin
J6, Pin 2	HDR1_28	AA24
J6, Pin 4	HDR1_42	V20
J6, Pin 6	HDR1_36	AC25
J6, Pin 8	HDR1_2	AC24
J6, Pin 10	HDR1_52	W25
J6, Pin 12	HDR1_32	AB24
J6, Pin 14	HDR1_26	Y24
J6, Pin 16	HDR1_12	AB23
J6, Pin 18	HDR1_50	W26
J6, Pin 20	HDR1_38	Y26
J6, Pin 22	HDR1_40	Y25
J6, Pin 24	HDR1_22	AA26
J6, Pin 26	HDR1_10	AA23
J6, Pin 28	HDR1_60	AC21
J6, Pin 30	HDR1_24	AB26
J6, Pin 32	HDR1_4	AC23
J6, Pin 34	HDR1_30	AB25
J6, Pin 36	HDR1_6	AD23
J6, Pin 38	HDR1_34	AC26
J6, Pin 40	HDR1_18	AD26
J6, Pin 42	HDR1_16	AC22
J6, Pin 44	HDR1_54	V22
J6, Pin 46	HDR1_56	V21
J6, Pin 48	HDR1_46	W22
J6, Pin 50	HDR1_20	AD25
J6, Pin 52	HDR1_14	AB22
J6, Pin 54	HDR1_48	W21
J6, Pin 56	HDR1_44	W20

Table 10: Expansion I/O Single-Ended Connections (J6) (Continued)

Header Pin	Label	FPGA Pin
J6, Pin 58	HDR1_58	AB21
J6, Pin 60	HDR1_8	AD22
J6, Pin 62	HDR1_62	AE24
J6, Pin 64	HDR1_64	AF24

Other Expansion I/O Connectors

In addition to the high-speed I/O paths, additional I/O signals and power connections are available to support expansion cards plugged into ML40x board (see [Table 11, page 23](#)). The 14 I/O pins from the general purpose buttons and LEDs on the board are connected to expansion connector J3. This arrangement permits additional I/Os to be connected to the expansion connector if the buttons and LEDs are not used. It also allows the expansion card to utilize the buttons and LEDs on the board.

The expansion connector also allows the board's JTAG chain to be extended onto the expansion card by setting jumper J26 accordingly.

The IIC bus on the board is also extended onto the expansion connector to allow additional IIC devices to be bused together. If the expansion IIC bus is to be utilized, the user must have the IIC pull-up resistors present on the expansion card. Bidirectional level shifting transistors allow the expansion card to utilize 2.5V to 5V signaling on the IIC bus.

Power supply connections to the expansion connectors provide ground, 2.5V, 3.3V, and 5V power pins. If the expansion card draws significant power from the ML40x board, the user must ensure that the total power draw can be supplied by the board.

The ML40x expansion connector is backward compatible with the expansion connectors on the ML320, ML321, and ML323 boards, thereby allowing their daughter cards to be used with the ML40x evaluation platform. [Table 11, page 23](#) summarizes the additional expansion I/O connections.

Table 11: Additional Expansion I/O Connections

Header Pin	Label	FPGA Pin	Description
J3, Pin 1	VCC5	N/A	5V Power Supply
J3, Pin 2	VCC5	N/A	5V Power Supply
J3, Pin 3	VCC5	N/A	5V Power Supply
J3, Pin 4	VCC5	N/A	5V Power Supply
J3, Pin 5	NC	N/A	Not Connected
J3, Pin 6	VCC3V3	N/A	3.3V Power Supply
J3, Pin 7	VCC3V3	N/A	3.3V Power Supply
J3, Pin 8	VCC3V3	N/A	3.3V Power Supply
J3, Pin 9	VCC3V3	N/A	3.3V Power Supply
J3, Pin 10	NC	N/A	Not Connected
J3, Pin 11	TMS	N/A	Expansion TMS
J3, Pin 12	TCK	N/A	Expansion TCK
J3, Pin 13	TDO	N/A	Expansion TDO
J3, Pin 14	TDI	N/A	Expansion TDI
J3, Pin 15	LED North	E2	LED North
J3, Pin 16	GPIO Switch North	E7	GPIO Switch North
J3, Pin 17	LED Center	C6	LED Center
J3, Pin 18	GPIO Switch Center	B6	GPIO Switch Center
J3, Pin 19	LED West	F9	LED West
J3, Pin 20	GPIO Switch West	E9	GPIO Switch West
J3, Pin 21	LED South	A5	LED South
J3, Pin 22	GPIO Switch South	A6	GPIO Switch South
J3, Pin 23	LED East	E10	LED East
J3, Pin 24	GPIO Switch East	F10	GPIO Switch East
J3, Pin 25	GPIO LED 0	G5	GPIO LED 0
J3, Pin 26	GPIO LED 1	G6	GPIO LED 1
J3, Pin 27	GPIO LED 2	A11	GPIO LED 2
J3, Pin 28	GPIO LED 3	A12	GPIO LED 3
J3, Pin 29	NC	N/A	Not Connected
J3, Pin 30	NC	N/A	Not Connected
J3, Pin 31	EXP_IIC_SCL	A17	Expansion IIC SCL
J3, Pin 32	EXP_IIC_SDA	B17	Expansion IIC SDA

11. Stereo AC97 Audio Codec

The ML40x board has an AC97 audio codec (U14) to permit audio processing. The National Semiconductor LM4550 Audio Codec supports stereo 16-bit audio with up to 48-kHz sampling. The sampling rate for record and playback can be different.

Note: The reset for the AC97 codec is shared with the reset signal for the flash memory chips and is designed to be asserted at power-on or upon system reset.

Separate audio jacks are provided for Microphone, Line In, Line Out, and Headphone. All jacks are stereo except for Microphone. The Headphone jack is driven by the audio codec's internal 50-mW amplifier. [Table 12](#) summarizes the audio jacks.

Table 12: ML40x Audio Jacks

Reference Designator	Function	Stereo/Mono
J11	Microphone - In	Mono
J12	Analog Line - In	Stereo
J13	Analog Line - Out	Stereo
J14	Headphone - Out	Stereo

12. RS-232 Serial Port

The ML40x board contains one male DB-9 RS-232 serial port allowing the FPGA to communicate serial data with another device. The serial port is wired as a host (DCE) device. Therefore, a null modem cable is normally required to connect the board to the serial port on a PC. The serial port is designed to operate up to 115200 Bd. An interface chip is used to shift the voltage level between FPGA and RS-232 signals.

Note: The FPGA is only connected to the TX and RX data pins on the serial port. Therefore, other RS-232 signals, including hardware flow control signals, are not used. Flow control should be disabled when communicating with a PC.

A secondary serial interface is available by using header J27 to support debug of the USB controller chip. Header J27 brings out RS-232 voltage level signals for ground, TX data, and RX data.

13. 16-Character x 2-Line LCD

The ML40x board has a 16-character x 2-line LCD (Lumex LCM-S01602DTR/M) on the board to display text information. Potentiometer R1 adjusts the contrast of the LCD. The data interface to the LCD is connected to the FPGA to support 4-bit mode only. A level translator chip is used to shift the voltage level between the FPGA and the LCD.

Caution! Care should be taken not to scratch or damage the surface of the LCD window. The protective layer of tape on the top of the screen should be left on for added protection of the screen's surface.

14. IIC Bus with 4-Kb EEPROM

An IIC EEPROM (Microchip Technology 24LC04B-I/ST) is provided on the ML40x board to store non-volatile data such as an Ethernet MAC address. The EEPROM write protect is tied off on the board to disable its hardware write protect. The IIC bus uses 2.5V signaling and can operate at up to 400 kHz. IIC bus pull-up resistors are provided on the board.

The IIC bus is extended to the expansion connector so that the user may add additional IIC devices and share the IIC controller in the FPGA. If the expansion IIC bus is to be utilized, the user must have additional IIC pull-up resistors present on the expansion card. Bidirectional level shifting transistors allow the expansion card to utilize 2.5V to 5V signaling on IIC.

15. VGA Output

The VGA output port (P2) supports an external video monitor. [Table 13](#) lists each board and its corresponding video DAC chip.

Table 13: Video DAC Connections

Board	Speed	Description	Video Monitor
ML401	50 MHz	24-bit video data bus connected to FPGA	Analog Devices ADV7125KST50
ML402	140 MHz		Analog Devices ADV7125KST140
ML403		15-bit video data bus connected to FPGA	

Note: Due to the reduced pin count on ML403 board's XC4VFX12 FPGA, only the five most significant bits of digital RGB data are connected to the video DAC. The three least significant bits of digital RGB data are pulled Low.

16. PS/2 Mouse and Keyboard Ports

The ML40x evaluation platform contains two PS/2 ports: one for a mouse (J17) and the other for a keyboard (J18). Bidirectional level shifting transistors allow the FPGA's 2.5V I/O to interface with the 5V I/O of the PS/2 ports. The PS/2 ports on the board are powered directly by the main 5V power jack, which also powers the rest of the board.

Caution! Care must be taken to ensure that the power load of any attached PS/2 devices does not overload the AC adapter.

17. System ACE and CompactFlash Connector

The Xilinx System ACE CompactFlash (CF) configuration controller allows a Type I or Type II CompactFlash card to program the FPGA through the JTAG port. Both hardware and software data can be downloaded through the JTAG port. The System ACE controller supports up to eight configuration images on a single CompactFlash card. The configuration address switches allow the user to choose which of the eight configuration images to use.

System ACE error and status LEDs indicate the operational state of the System ACE controller:

- A blinking red error LED indicates that no CompactFlash card is present
- A solid red error LED indicates an error condition during configuration
- A blinking green status LED indicates a configuration operation is ongoing
- A solid green status LED indicates a successful download

Every time a CompactFlash card is inserted into the System ACE socket, a configuration operation is initiated. Pressing the System ACE reset button re-programs the FPGA.

The board also features a System ACE *failsafe* mode. In this mode, if the System ACE controller detects a failed configuration attempt, it automatically reboots back to a predefined configuration image. The failsafe mode is enabled by inserting two jumpers across J29 and J30 (in horizontal or vertical orientation).

Caution! Use caution when inserting a CompactFlash card with exposed metallic surfaces. Improper insertion can cause a short with the traces or components on the board.

The System ACE MPU port is connected to the FPGA. This connection allows the FPGA to use the System ACE controller to reconfigure the system or access the CompactFlash card as a generic FAT file system. The data bus for the System ACE MPU port is shared with the USB controller.

For configuration through the System ACE controller, the configuration selector switch (SW12) must be set to the SYS ACE position.

18. ZBT Synchronous SRAM

The ZBT synchronous SRAM (Cypress CY7C1354B or compatible) provides high-speed, low-latency external memory to the FPGA. The memory is organized as 256K x 36 bits. This organization provides for a 32-bit data bus with support for four parity bits. On ML403, the parity bits are not accessible.

Note: The SRAM and FLASH memory share the same data bus.

19. Linear Flash Chips

Two 32-Mb linear flash devices (Micron MT28F320J3RG-11 ET) are installed on the board for a total of 8 MB of flash memory. These flash memory chips are Intel StrataFlash compatible. This memory provides non-volatile storage of data, software, or bitstreams. Each flash chip is 16 bits wide and together forms a 32-bit data bus that is shared with SRAM. In conjunction with a CPLD, the flash memory can also be used to program the FPGA.

Note: The reset for the AC97 Codec is shared with the reset signal for the flash memory chips and is designed to be asserted at power-on or upon system reset.

20. Xilinx XC95144XL CPLD

A Xilinx XC95144XL CPLD is connected to the flash memory and the FPGA configuration signals. This CPLD connection supports applications where flash memory programs the FPGA. The CPLD is programmed from the main JTAG chain of the board. The CPLD is wired so that it can support master or slave configuration in serial or parallel (SelectMAP) modes. For FPGA configuration via the CPLD and flash, the configuration selector switch (SW12) must be set to the CPLD Flash position. See the “[Configuration Options](#),” page 31 section for more information.

21. 10/100/1000 Tri-Speed Ethernet PHY

The ML40x evaluation platform contains a Marvell Alaska PHY device (88E1111) operating at 10/100/1000 Mb/s. The board supports MII, GMII, and RGMII interface modes with the FPGA. The PHY is connected to a Halo HFJ11-1G01E RJ-45 connector with built-in magnetics. A 25-MHz crystal supplies the clock signal to the PHY. The PHY is configured to default at power-on or reset to the following settings (See [Table 14](#)). These settings may be overwritten via software.

Table 14: Board Connections for PHY Configuration Pins

Config Pin	Connection on Board	Bit[2] Definition and Value	Bit[1] Definition and Value	Bit[0] Definition and Value
CONFIG0	Ground	PHYADR[2] = 0	PHYADR[1] = 0	PHYADR[0] = 0
CONFIG1	Ground	ENA_PAUSE = 0	PHYADR[4] = 0	PHYADR[3] = 0
CONFIG2	V _{CC} 2.5V	ANEG[3] = 1	ANEG[2] = 1	ANEG[1] = 1
CONFIG3	V _{CC} 2.5V	ANEG[0] = 1	ENA_XC = 1	DIS_125 = 1
CONFIG4	V _{CC} 2.5V	HWCFG_MODE[2] = 1	HWCFG_MODE[1] = 1	HWCFG_MODE[0] = 1
CONFIG5	V _{CC} 2.5V	DIS_FC = 1	DIS_SLEEP = 1	HWCFG_MODE[3] = 1
CONFIG6	LED_RX	SEL_BDT = 0	INT_POL = 1	75/50Ω = 0

22. USB Controller with Host and Peripheral Ports

A Cypress CY7C67300 embedded USB host controller provides USB connectivity for the board. The USB controller supports host and peripheral modes of operation. The USB controller has two serial interface engines (SIE) that can be used independently. SIE1 is connected to the USB Host 1 connector (J19) and the USB Peripheral 1 connector (J2). SIE2 is connected only to the USB Peripheral 2 connector.

Note: When using SIE1, the port can only be configured at boot-up to use either the host or peripheral connector, but not both at the same time.

The USB controller has an internal microprocessor to assist in processing USB commands. The firmware for this processor can be stored in its own dedicated IIC EEPROM (U17) or can be downloaded from a host computer via a peripheral connector. The USB controller's serial port is connected to J27 through an RS-232 transceiver to assist with debug.

23. Xilinx XCF32P Platform Flash Configuration Storage Device

Xilinx XCF32P Platform Flash configuration storage device offers a convenient and easy-to-use configuration solution for the FPGA. The Platform Flash memory holds up to four separate configuration images (two images on the ML402 board) that can be accessed through the configuration address switches. To use the Platform Flash memory to configure the FPGA, the configuration selector switch (SW12) must be set to the Plat Flash position.

The Platform Flash memory can program the FPGA by using the master or slave configuration in serial or parallel (SelectMap) modes. The Platform Flash memory is programmed using Xilinx iMPACT software through the board's JTAG chain. See the "[Configuration Options](#)," page 31 section for more information.

24. JTAG Configuration Port

The JTAG configuration port for the board (J20) allows for device programming and FPGA debug. The JTAG port supports the Xilinx Parallel Cable III or Parallel Cable IV products. Third-party configuration products might also be available. The JTAG chain can also be extended to an expansion board by setting jumper J26 accordingly. See the "[Configuration Options](#)," page 31 section for more information.

25. Onboard Power Supplies

Power supply circuitry on the board generates 1.2V, 1.25V, 1.8V, 2.5V, and 3.3V voltages to power the components on the board. The 1.2V, 2.5V, and 3.3V supplies are driven by switching power regulators. When these three switching regulators report they are running at their nominal voltages, the PWR Good LED is turned on.

The diagram in [Figure 4](#) shows the power supply architecture and maximum current handling on each supply. The typical operating currents are significantly below the maximum capable. The ML40x board is normally shipped with a 15W power supply which should be sufficient for most applications.

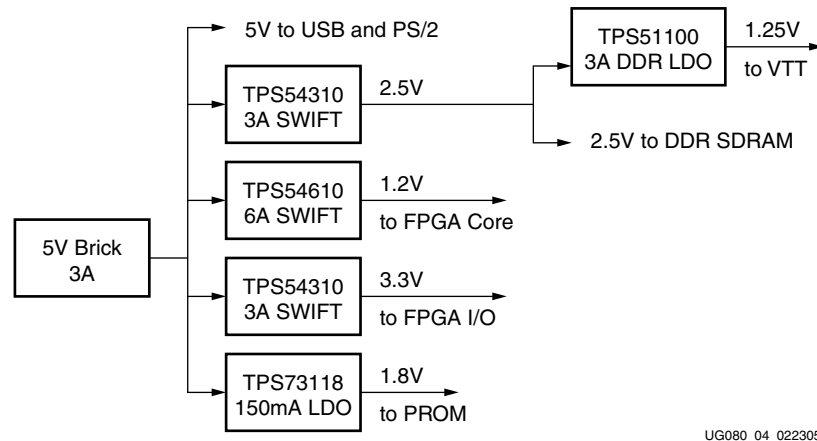

Figure 4: Power Supply Diagram

26. AC Adapter and Input Power Switch/Jack

The ML40x board ships with a 15W (5V @ 3A) AC adapter. The power connector is a 2.1 mm x 5.5 mm barrel type plug (center positive). For applications requiring additional power, such as the use of expansion cards drawing significant power, a larger AC adapter might be required. If a different AC adapter is used, its load regulation should be less than 10% or better than $\pm 10\%$. The power switch turns the board on and off by controlling the supply of 5V to the board.

27. Power Indicator LED

The PWR Good LED lights when the 1.2V, 2.5V, and 3.3V power supplies are all at their nominal operating conditions. If the PWR Good LED is off, blinking, or glowing lightly, this indicates a fault condition, such as a short or overload condition, might exist.

28. INIT LED

The INIT LED lights upon power-up to indicate that the FPGA has successfully powered up and completed its internal power-on process.

29. DONE LED

The DONE LED indicates the status of the DONE pin on the FPGA. It should be lighted when the FPGA is successfully configured.

30. Program Switch

This switch grounds the FPGA's Prog pin when pressed. This action clears the FPGA.

31. Configuration Address and Mode DIP Switches

This 6-position DIP switch controls the configuration address and FPGA configuration mode.

The three leftmost switches choose one of eight possible configuration addresses. These three DIP switches provide the System ACE controller and the CPLD the possibility of using up to eight different configuration images as set by these three switches. The Platform Flash memory supports up to four different images.

The three rightmost DIP switches set the FPGA configuration mode pins M2, M1, and M0 as shown in [Table 15](#).

Table 15: Configuration Mode DIP Switch Settings

M2	M1	M0	Mode
0	0	0	Master Serial
1	1	1	Slave Serial
0	1	1	Master Parallel (SelectMAP)
1	1	0	Slave Parallel (SelectMAP)
1	0	1	JTAG

32. Encryption Key Battery

An onboard battery holder is connected to the V_{BATT} pin of the FPGA to hold the encryption key for the FPGA. A 12-mm lithium coin battery (3V), such as Panasonic part numbers BR1216, CR1216, and BR1225, or any other appropriate 12-mm lithium coin battery (3V) can be used.

33. Configuration Source Selector Switch

The configuration source selector switch (SW12) selects between System ACE, Platform Flash, and linear flash/CPLD methods of programming the FPGA. Whichever method is selected to program the FPGA, make sure the FPGA configuration mode switches are set appropriately for the desired method of configuration. The PC4 connector allows JTAG download and debug of the board regardless of the setting of the configuration source selector switch.

Configuration Options

The FPGA on the ML40x evaluation platform can be configured by four major devices:

- Parallel Cable IV cable (JTAG)
- System ACE controller (JTAG)
- Platform Flash memory
- Linear flash + CPLD

The following section provides an overview of the possible ways the board can be configured.

JTAG (Parallel Cable IV Cable and System ACE Controller)

The FPGA, Platform Flash memory, and CPLD can be configured through the JTAG port. The JTAG chain of the board is illustrated in [Figure 5](#).

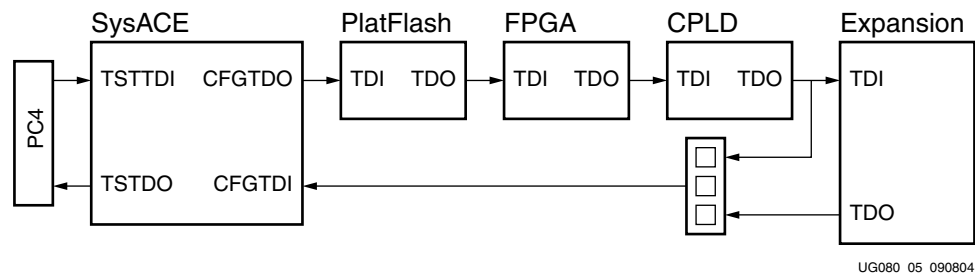

Figure 5: JTAG Chain

The chain starts at the PC4 connector and goes through the System ACE controller, the Platform Flash memory, the FPGA, the CPLD, and an optional extension of the chain to the expansion card. Jumper J26 determines if the JTAG chain should be extended to the expansion card.

The JTAG chain can be used to program the FPGA and access the FPGA for hardware and software debug. The JTAG chain is also used to program the Platform Flash memory and the CPLD.

The PC4 JTAG connection to the JTAG chain allows a host PC to download bitstreams to the FPGA using the iMPACT software tool. PC4 also allows debug tools such as the ChipScope™ Pro Analyzer or a software debugger to access the FPGA.

The System ACE controller can also program the FPGA through the JTAG port. Using an inserted CompactFlash card or Microdrive storage device, configuration information can be stored and played out to the FPGA. The System ACE controller supports up to eight configuration images that can be selected using the three configuration address DIP switches. Under FPGA control, the System ACE chip can be instructed to reconfigure to any of the eight configuration images.

The configuration source selector switch should be in the SYS ACE setting if the use of the System ACE controller is desired.

When set correctly, the System ACE controller programs the FPGA upon power-up if a CompactFlash card is present or whenever a CompactFlash card is inserted. Pressing the System ACE reset button also causes the System ACE controller to program the FPGA if a CompactFlash card is present.

Platform Flash Memory

The Platform Flash memory can also be used to program the FPGA. The Platform Flash memory can hold up to four configuration images, which are selectable by the two least significant bits of the configuration address DIP switches.

Note: ML402 Platform Flash memory can hold two configuration images, which are selectable by the least significant bit of the configuration address DIP switches.

The board is wired so the Platform Flash memory can download bitstreams in Master Serial, Slave Serial, Master SelectMAP (parallel), or Slave SelectMAP (parallel) modes. Using the iMPACT tool to program the Platform Flash memory, the user has the option to select which of the four modes to use for programming the FPGA. The configuration mode DIP switches on the board must be set to match the programming method being used by the Platform Flash memory.

The configuration source selector switch should be in the Plat Flash setting if the use of Platform Flash memory is desired.

When set correctly, the Platform Flash memory programs the FPGA upon power-up or whenever the Prog button is pressed.

Linear Flash + CPLD

Data stored in the linear flash can be read by the CPLD and used to program the FPGA. Depending on the logic design in the CPLD, up to eight configuration images can theoretically be supported.

Note: Note: ML402 linear flash can hold up to four configuration images.

The board is wired so the CPLD can download bitstreams via Master Serial, Slave Serial, Master SelectMAP (parallel), or Slave SelectMAP (parallel) modes. The configuration mode DIP switches on the board must be set to match the programming method being used by the CPLD.

The configuration source selector switch should be in the CPLD Flash setting if the use of CPLD + Platform Flash is desired.

When set correctly, the CPLD programs the FPGA upon power-up or whenever the Prog button is pressed.