

SECT. "Z-Z"

NOTES:

1. MATERIAL: SEE TABLE
2. FINISHES: SEE TABLE
3. PRODUCT SPECIFICATION: NOT REQUIRED
4. PACKAGING: NOT REQUIRED
5. MATES WITH: 90 SERIES PLUG
6. "XX" REFERS TO THE NUMBER OF CIRCUITS.
7. SEE DWG SD-38120-003 FOR PRINTING OPTIONS.

ITEM	QTY.	DESCRIPTION	MATERIAL	FINISH
2	XX	HEADER PIN	BRASS	TIN PLATE
1	1	HEADER	PBT	SEE TABLE

EC NO. 4105 DRWN: GHR 5-2-05 CHK: K APPR: C REV	QUALITY SYMBOLS MAJOR CRITICAL SPC	GENERAL TOLERANCES: (UNLESS SPECIFIED)		SCALE 3:1	DESIGN UNITS <input type="checkbox"/> mm <input checked="" type="checkbox"/> INCH	THIRD ANGLE PROJECTION	PROJECT NO. - DIMENSIONS: <input checked="" type="checkbox"/> mm <input type="checkbox"/> INCH <input type="checkbox"/> mm <input type="checkbox"/> ONLY	SHT REV
		4 PLACES ±.0015 3 PLACES ±.038 ±.005 2 PLACES ±.13 ±.01 1 PLACE ±.3	DRAWN BY & DATE W. HOWARD 10-9-03	TITLE: HEADER, VERTICAL 3.81 (.150)				
		ANGULAR: ±2°	CHECKED BY & DATE L.ROTHAUS 10-9-03	APPROVED BY & DATE L.ROTHAUS 10-9-03				
		DRAFT WHERE APPLICABLE MUST REMAIN WITHIN DIMENSIONS	CAD FILENAME 9016XX	MATERIAL NO. SEE TABLE	DRAWING NO. SD-39900-001	SHEET NO. 1 OF 2		
THIS DRAWING CONTAINS INFORMATION THAT IS PROPRIETARY TO MOLEX INCORPORATED AND SHOULD NOT BE USED WITHOUT WRITTEN PERMISSION.							SIZE B	



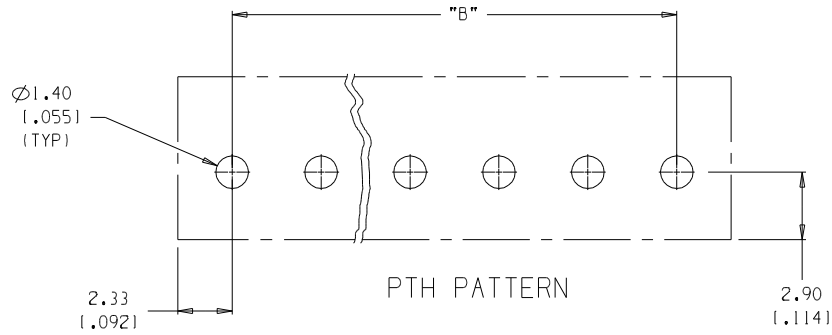

NUMBER OF CIRCUITS "XX"	DIM. "A"	DIM. "B"	MATERIAL NO. (G30, BLACK)	MATERIAL NO. (GREEN)	MATERIAL NO. (10AV, BLACK)	MATERIAL NO. (BLACK)
02	8.5 (1.33)	3.81 (1.150)	39901-0502	39900-3502		39900-0502
03	12.3 (1.48)	7.62 (1.300)	39901-0503	39900-3503	39902-0503	39900-0503
04	16.1 (1.63)	11.43 (1.450)	39901-0504	39900-3504		39900-0504
05	19.9 (1.78)	15.24 (1.600)	39901-0505	39900-3505		39900-0505
06	23.7 (1.93)	19.05 (1.750)	39901-0506	39900-3506		39900-0506
07	27.5 (1.08)	22.86 (1.900)	39901-0507	39900-3507		39900-0507
08	31.3 (1.23)	26.67 (1.050)	39901-0508	39900-3508		39900-0508
09	35.1 (1.38)	30.48 (1.200)	39901-0509	39900-3509		39900-0509
10	39.0 (1.53)	34.29 (1.350)	39901-0510	39900-3510		39900-0510
11	42.8 (1.68)	38.10 (1.500)	39901-0511	39900-3511		39900-0511
12	46.6 (1.83)	41.91 (1.650)	39901-0512	39900-3512		39900-0512
13	50.4 (1.98)	45.72 (1.800)	39901-0513	39900-3513		39900-0513
14	54.2 (2.13)	49.53 (1.950)	39901-0514	39900-3514		39900-0514
15	58.0 (2.28)	53.34 (2.100)	39901-0515	39900-3515		39900-0515
16	61.8 (2.43)	57.15 (2.250)	39901-0516	39900-3516	39902-0516	39900-0516
17	65.6 (2.58)	60.96 (2.400)	39901-0517	39900-3517		39900-0517
18	69.4 (2.73)	64.77 (2.550)	39901-0518	39900-3518		39900-0518
19	73.2 (2.88)	68.58 (2.700)	39901-0519	39900-3519		39900-0519
20	77.1 (3.03)	72.39 (2.850)	39901-0520	39900-3520		39900-0520
21	80.9 (3.18)	76.20 (3.000)	39901-0521	39900-3521		39900-0521

PROJECT NO. -	-	-
DIMENSIONS:	SHT	REV
<input checked="" type="checkbox"/> mm	<input type="checkbox"/> INCH	<input type="checkbox"/> mm ONLY
	REVISE ON CAD ONLY	

EC NO. SEE SHEET 1 DRAWN: CH'K: APPR: REV: DESCRIPTION	QUALITY SYMBOLS MAJOR: CRITICAL: SPC: S:	GENERAL TOLERANCES: (UNLESS SPECIFIED) <table border="1"> <tr> <th></th> <th>mm</th> <th>INCH</th> </tr> <tr> <td>4 PLACES</td> <td></td> <td>±.0015</td> </tr> <tr> <td>3 PLACES</td> <td>±.038</td> <td>±.005</td> </tr> <tr> <td>2 PLACES</td> <td>±.13</td> <td>±.01</td> </tr> <tr> <td>1 PLACE</td> <td>±.3</td> <td></td> </tr> </table>		mm	INCH	4 PLACES		±.0015	3 PLACES	±.038	±.005	2 PLACES	±.13	±.01	1 PLACE	±.3		SCALE: 3:1 DESIGN UNITS: <input type="checkbox"/> mm <input checked="" type="checkbox"/> INCH THIRD ANGLE PROJECTION:	DRAWN BY & DATE: W. HOWARD 10-9-03 CHECKED BY & DATE: L.ROTHAUS 10-9-03 APPROVED BY & DATE: L.ROTHAUS 10-9-03	TITLE: HEADER, VERTICAL 3.81 (1.150)
		mm	INCH																	
	4 PLACES		±.0015																	
	3 PLACES	±.038	±.005																	
2 PLACES	±.13	±.01																		
1 PLACE	±.3																			
ANGULAR: ±2° DRAFT WHERE APPLICABLE MUST REMAIN WITHIN DIMENSIONS		CAD FILENAME: 9016XX	MATERIAL NO.: SEE TABLE	DRAWING NO.: SD-39900-001	SHEET NO.: 2 OF 2															
THIS DRAWING CONTAINS INFORMATION THAT IS PROPRIETARY TO MOLEX INCORPORATED AND SHOULD NOT BE USED WITHOUT WRITTEN PERMISSION.																				
					SIZE: B															