

PHOTONIC DETECTORS INC.

Silicon Photodiode, Near I.R. Photoconductive Type PDI-C109-F

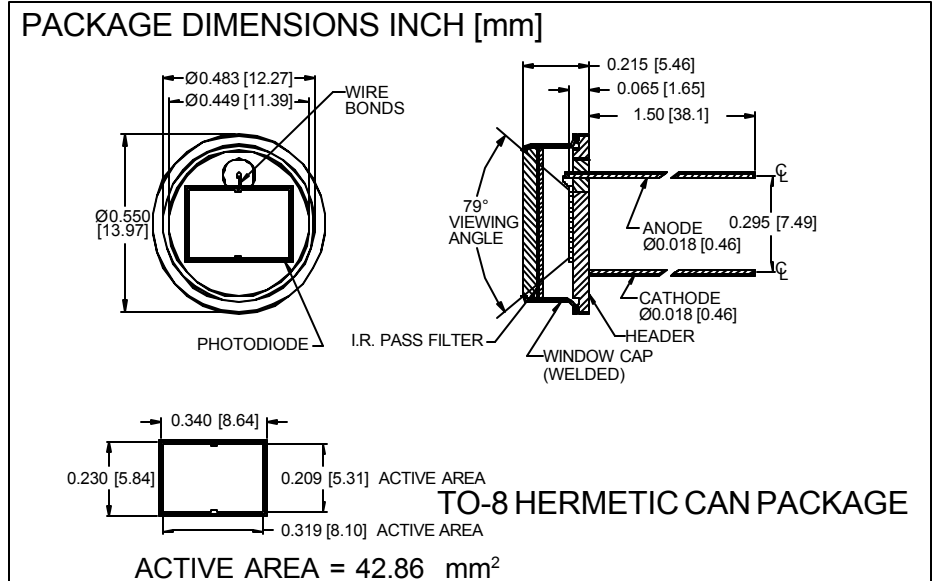

FEATURES

- High speed
- I.R. pass visible rejection
- Match to I.R. emitters
- Hermetic package

DESCRIPTION

The **PDI-C109-F** is a silicon, PIN planar diffused photodiode with NIR pass, visible light rejection optical filter. Ideal for high speed, low capacitance, photoconductive NIR applications. Packaged in a hermetic TO-8 metal can with a flat window cap.

APPLICATIONS

- I.R. detector
- I.R. laser detector
- Photo-interrupters
- Industrial controls

ABSOLUTE MAXIMUM RATING (TA=25°C unless otherwise noted)

SYMBOL	PARAMETER	MIN	MAX	UNITS
V _{BR}	Reverse Voltage		100	V
T _{STG}	Storage Temperature	-55	+100	°C
To	Operating Temperature Range	-40	+80	°C
T _s	Soldering Temperature*		+240	°C
I _L	Light Current		500	mA

*1/16 inch from case for 3 secs max

SPECTRAL RESPONSE

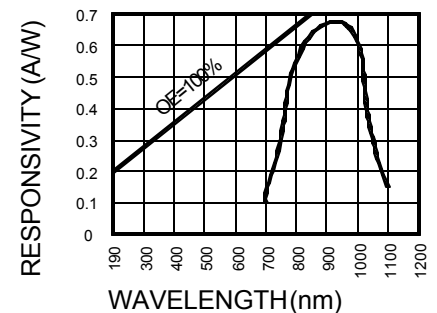

ELECTRO-OPTICAL CHARACTERISTICS (TA=25°C unless otherwise noted)

SYMBOL	CHARACTERISTIC	TEST CONDITIONS	MIN	TYP	MAX	UNITS
I _{sc}	Short Circuit Current	H = 100 fc, 2850 K	405	450		μA
I _D	Dark Current	H = 0, V _R = 10 V		5	15	nA
R _{SH}	Shunt Resistance	H = 0, V _R = 10 mV	30	100		MΩ
TC R _{SH}	RSH Temp. Coefficient	H = 0, V _R = 10 mV		-8		% / °C
C _J	Junction Capacitance	H = 0, V _R = 10 V**		120		pF
λ _{range}	Spectral Application Range	Spot Scan	700		1100	nm
λ _p	Spectral Response - Peak	Spot Scan		950		nm
V _{BR}	Breakdown Voltage	I = 10 μA	30	50		V
NEP	Noise Equivalent Power	V _R = 10 V @ Peak		5x10 ⁻¹³		W/√Hz
t _r	Response Time	R _L = 1 KΩ V _R = 50 V		25		nS

Information in this technical data sheet is believed to be correct and reliable. However, no responsibility is assumed for possible inaccuracies or omission. Specifications are subject to change without notice.**f = 1 MHz

[FORM NO. 100-PDI-C109-F REV A]