

EBTF-4-XX-2.0-X-RA-X-X-X

No OF PAIRS PER COLUMN
-4

COLUMNS

- 06
- 08
- 10

COLUMN PITCH

-2.0: 2.0 mm

PLATING SPECIFICATION

-S: 30μ" SELECTIVE GOLD
IN CONTACT AREA,
MATTE TIN ON TAIL

ORIENTATION

-RA: RIGHT ANGLE

KEYING

(ONLY AVAILABLE WITH -L OR -R GUIDANCE)
BLANK: NO KEYING
-A THRU -H: DENOTES POSITION OF FLAT ON KEY
(SEE KEYING POSITION TABLE, SHT 5)

GUIDANCE

BLANK: NONE
-L: LEFT
-R: RIGHT

PIN CONFIGURATION

-1: STANDARD

(** = NOT RELEASED)

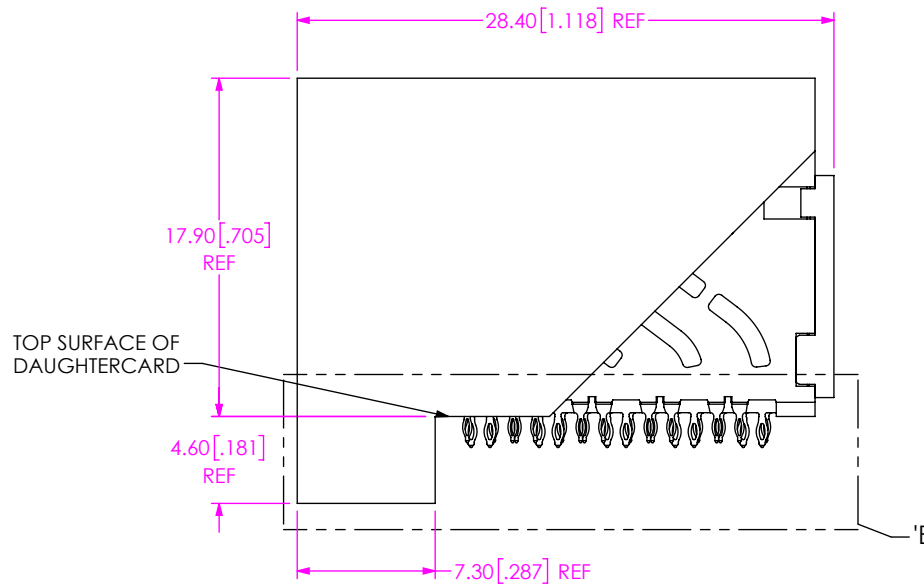
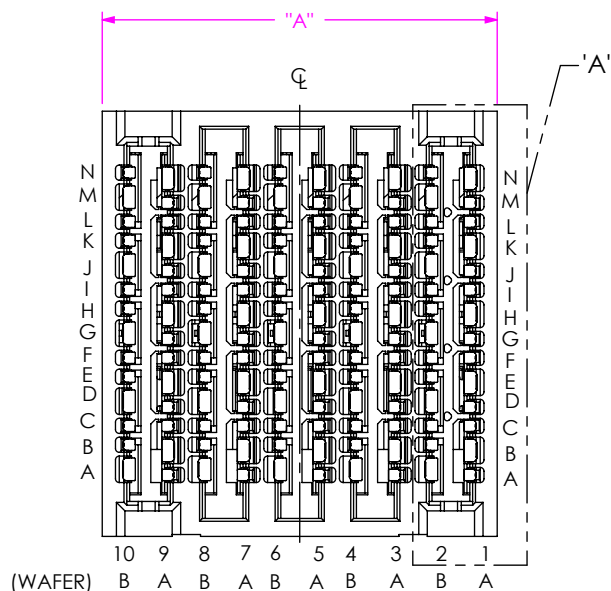

FIG 1
EBTF-4-10-2.0-X-RA-1 SHOWN

TABLE 1				
COLUMNS	"A"	"B"	"C"	
-06	12.90 [0.508]	10.00 [0.394]	5.20 [0.205]	
-08	16.90 [0.665]	14.00 [0.551]	7.20 [0.283]	
-10	20.90 [0.823]	18.00 [0.709]	9.20 [0.362]	

NOTES:

1. MINIMUM PUSHOUT FORCE: 2.22N [.5 LB]
2. CONTACT SAMTEC FOR CONNECTOR PRESS FIT INSTRUCTIONS.
3. TRAYS TO BE STANDARD PACKAGING.
4. ORDERS WILL BE PACKAGED ACCORDING TO THE SAMTEC PACKAGING EFFICIENCY STANDARDS (SPES) FOUND ON WWW.SAMTEC.COM

UNLESS OTHERWISE SPECIFIED, DIMENSIONS ARE IN MILLIMETERS [INCHES].
TOLERANCES ARE:
DECIMALS ANGLES
X.X: ±0.3 [.01] 2°
X.XX: ±0.10 [.004]
X.XXX: ±0.050 [.0019]

PROPRIETARY NOTE
THIS DOCUMENT CONTAINS CONFIDENTIAL AND PROPRIETARY INFORMATION AND ALL DESIGN, MANUFACTURING, REPRODUCTION, USE, PATENT RIGHTS AND SALES RIGHTS ARE EXPRESSLY RESERVED BY SAMTEC, INC. THIS DOCUMENT SHALL NOT BE DISCLOSED, IN WHOLE OR PART, TO ANY UNAUTHORIZED PERSON OR ENTITY NOR REPRODUCED, TRANSFERRED OR INCORPORATED IN ANY OTHER PROJECT IN ANY MANNER WITHOUT THE EXPRESS WRITTEN CONSENT OF SAMTEC, INC.

MATERIAL: DO NOT SCALE DRAWING SHEET SCALE: 3:1

INSULATOR: LCP, UL 94-V0; COLOR: BLACK
CONTACT: COPPER ALLOY
SHIELD: COPPER ALLOY



520 PARK EAST BLVD, NEW ALBANY, IN 47150
PHONE: 812-944-6733 FAX: 812-948-5047
e-Mail: info@SAMTEC.com code 53322

DESCRIPTION:
EXAMAX™ RIGHT ANGLE RECEPTACLE ASSEMBLY

DWG. NO.
EBTF-4-XX-2.0-X-RA-X-X-X

BY: ROY LUO 10/03/2014 SHEET 1 OF 5

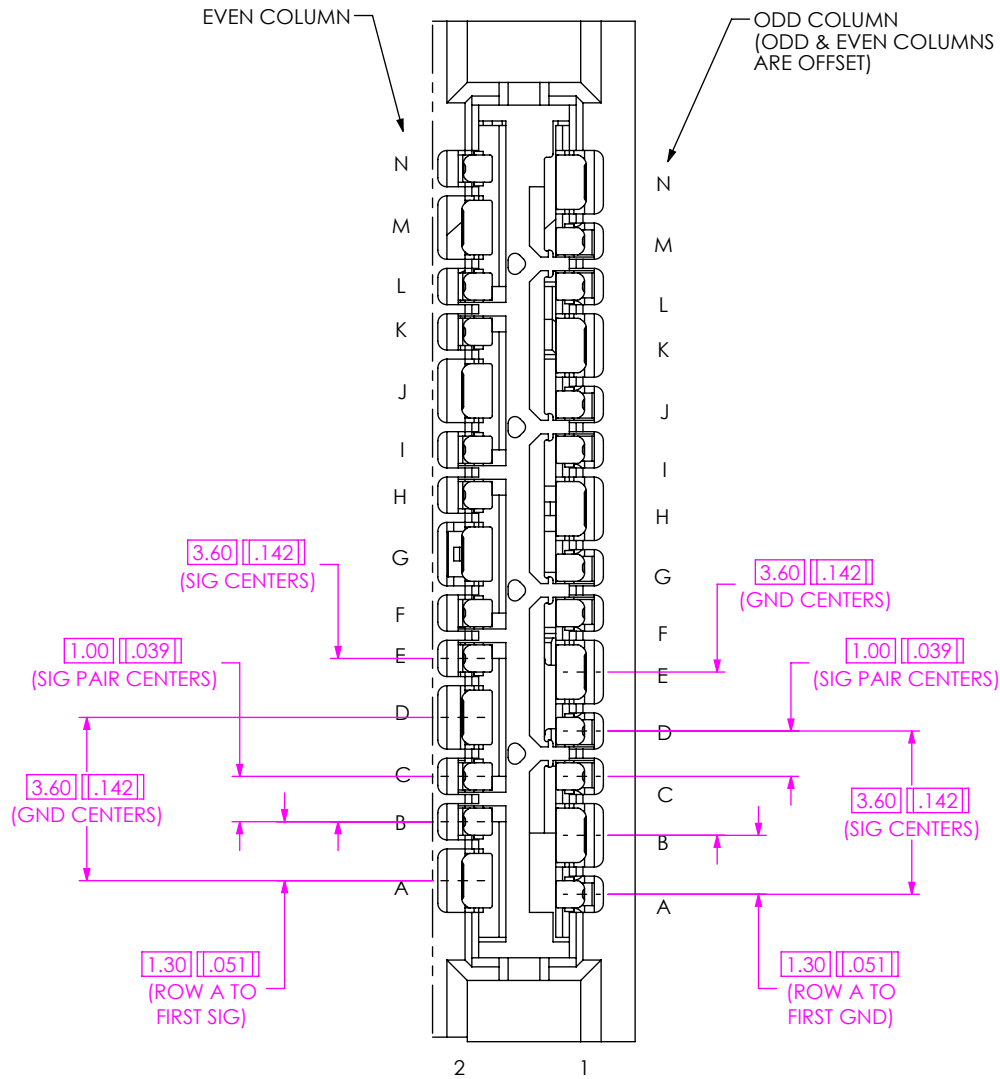

DETAIL 'A'
SCALE 6:1

PROPRIETARY NOTE

THIS DOCUMENT CONTAINS CONFIDENTIAL AND PROPRIETARY INFORMATION AND ALL DESIGN, MANUFACTURING, REPRODUCTION, USE, PATENT RIGHTS AND SALES RIGHTS ARE EXPRESSLY RESERVED BY SAMTEC, INC. THIS DOCUMENT SHALL NOT BE DISCLOSED, IN WHOLE OR PART, TO ANY UNAUTHORIZED PERSON OR ENTITY NOR REPRODUCED, TRANSFERRED OR INCORPORATED IN ANY OTHER PROJECT IN ANY MANNER WITHOUT THE EXPRESS WRITTEN CONSENT OF SAMTEC, INC.

DO NOT SCALE DRAWING

SHEET SCALE: 2:1



520 PARK EAST BLVD. NEW ALBANY, IN 47150
PHONE: 812-944-6733 FAX: 812-948-5047
e-Mail info@SAMTEC.com code 55322

DESCRIPTION:
EXAMAX™ RIGHT ANGLE RECEPTACLE ASSEMBLY

DWG. NO.
EBTF-4-XX-2.0-X-RA-X-X-X

BY: ROY LUO 10/03/2014 SHEET 2 OF 5

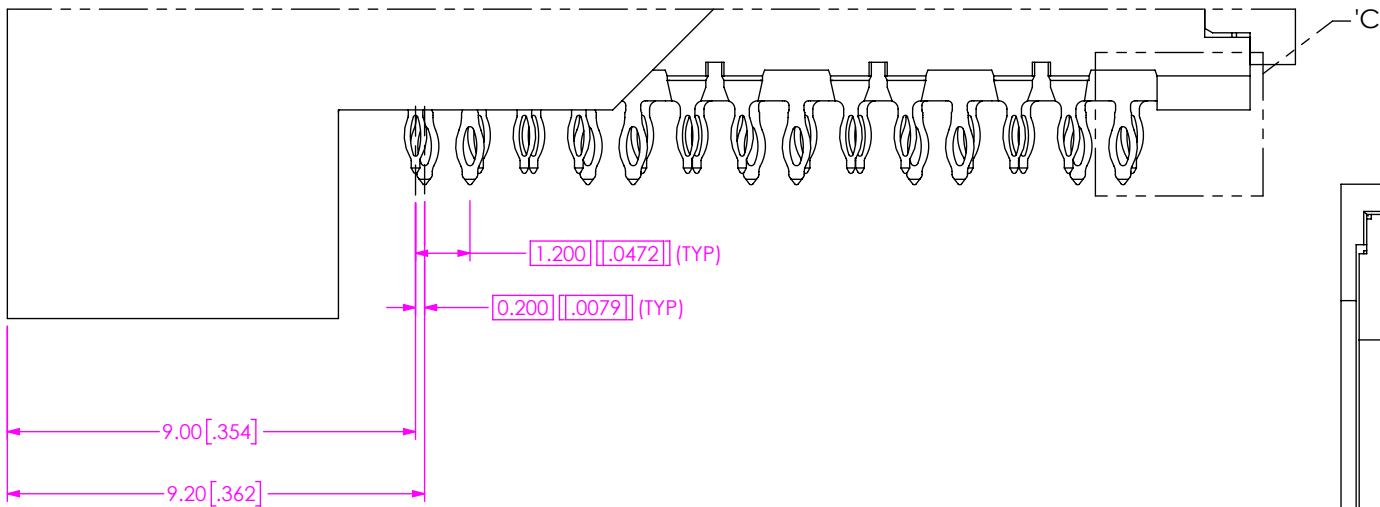

DETAIL 'B'
SCALE 6 : 1

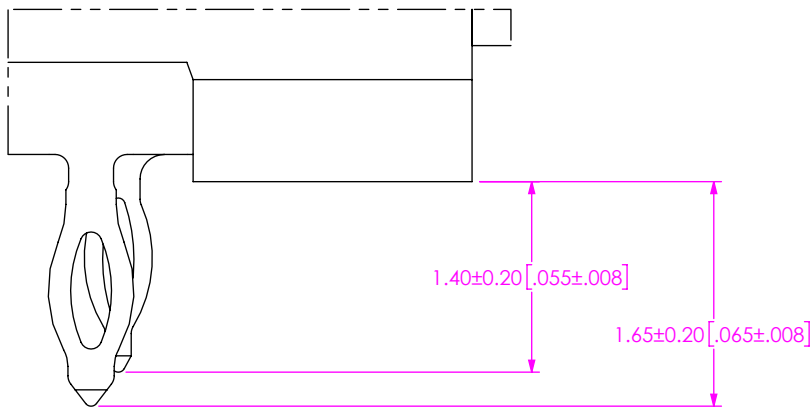

DETAIL 'C'
SCALE 18 : 1

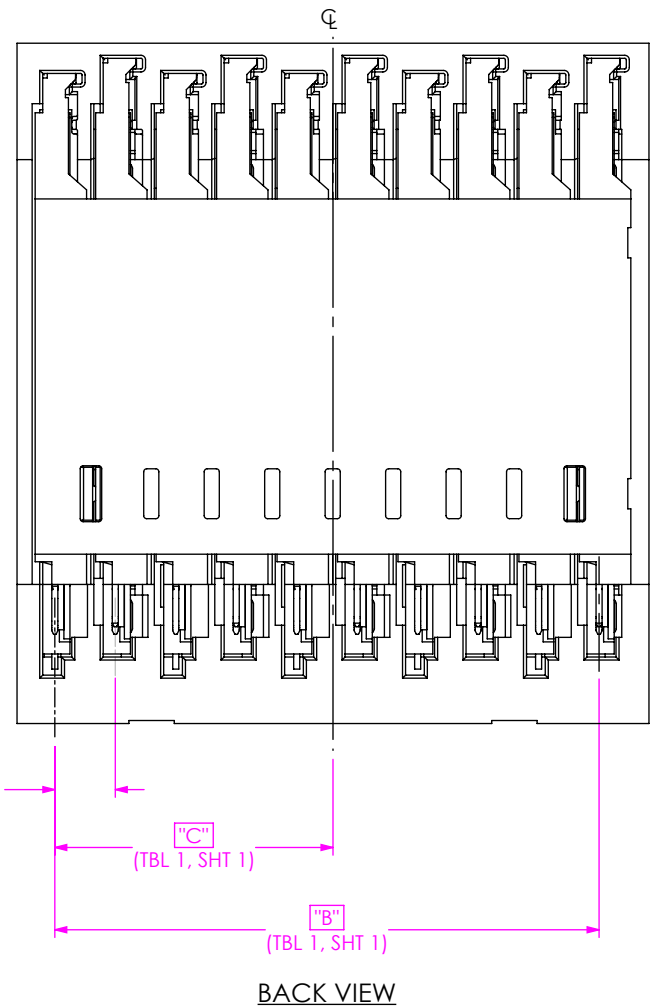

PROPRIETARY NOTE
 THIS DOCUMENT CONTAINS CONFIDENTIAL AND PROPRIETARY INFORMATION AND ALL DESIGN, MANUFACTURING, REPRODUCTION, USE, PATENT RIGHTS AND SALES RIGHTS ARE EXPRESSLY RESERVED BY SAMTEC, INC. THIS DOCUMENT SHALL NOT BE DISCLOSED, IN WHOLE OR PART, TO ANY UNAUTHORIZED PERSON OR ENTITY NOR REPRODUCED, TRANSFERRED OR INCORPORATED IN ANY OTHER PROJECT IN ANY MANNER WITHOUT THE EXPRESS WRITTEN CONSENT OF SAMTEC, INC.

DO NOT SCALE DRAWING

SHEET SCALE: 4:1



520 PARK EAST BLVD. NEW ALBANY, IN 47150
 PHONE: 812-944-6733 FAX: 812-948-5047
 e-Mail info@SAMTEC.com code 55322

DESCRIPTION:
 EXAMAX™ RIGHT ANGLE RECEPTACLE ASSEMBLY

DWG. NO.
 EBTF-4-XX-2.0-X-RA-X-X-X

BY: ROY LUO 10/03/2014 SHEET 3 OF 5

TABLE 2					
COLUMNS	"D"		"E"		
-06	18.85	[0.742]	9.20	[0.362]	
-08	22.85	[0.900]	11.20	[0.441]	
-10	26.85	[1.057]	13.20	[0.520]	

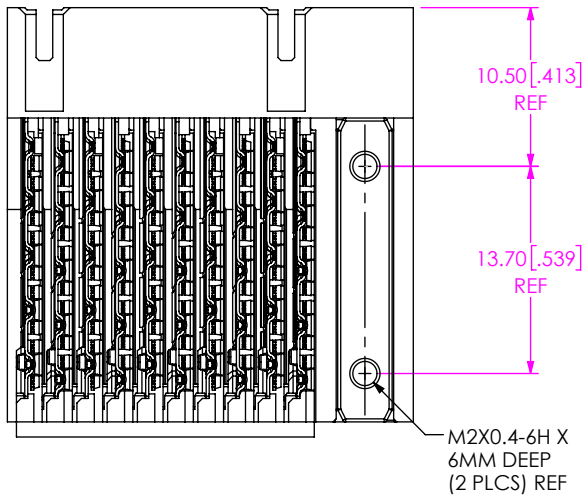
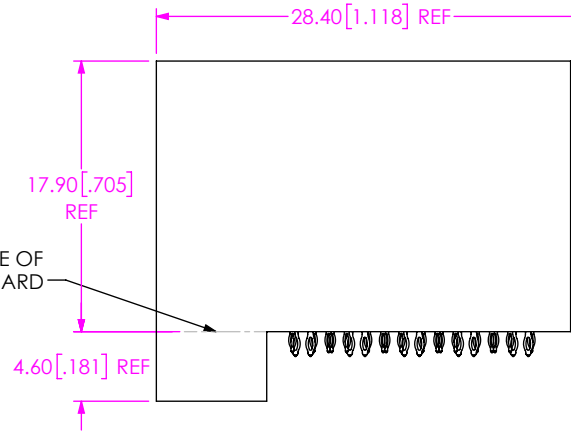
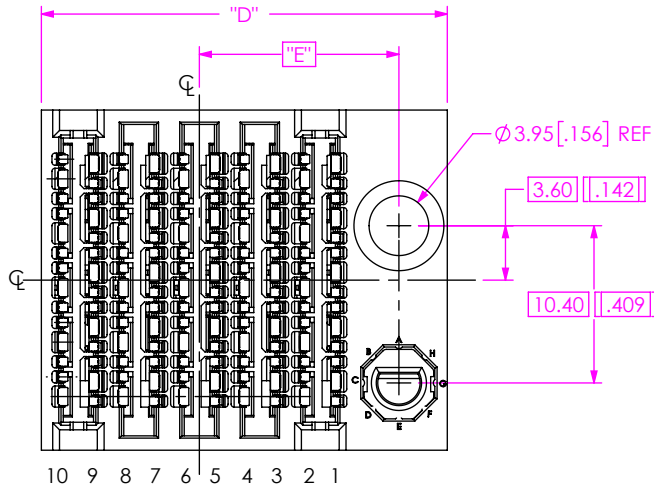

FIG 5
RIGHT GUIDANCE
EBTF-4-10-2.0-X-RA-X-R-A SHOWN
(DIFFERENT AS SHOWN, OTHERWISE SAME AS FIG 1)

KEYING POSITION TABLE

		KEYING							
		-A	-B	-C	-D	-E	-F	-G	-H
-R / -L									

PROPRIETARY NOTE
THIS DOCUMENT CONTAINS CONFIDENTIAL AND PROPRIETARY INFORMATION AND ALL DESIGN, MANUFACTURING, REPRODUCTION, USE, PATENT RIGHTS AND SALES RIGHTS ARE EXPRESSLY RESERVED BY SAMTEC, INC. THIS DOCUMENT SHALL NOT BE DISCLOSED, IN WHOLE OR PART, TO ANY UNAUTHORIZED PERSON OR ENTITY NOR REPRODUCED, TRANSFERRED OR INCORPORATED IN ANY OTHER PROJECT IN ANY MANNER WITHOUT THE EXPRESS WRITTEN CONSENT OF SAMTEC, INC.

DO NOT SCALE DRAWING

SHEET SCALE: 2:1



520 PARK EAST BLVD. NEW ALBANY, IN 47150
PHONE: 812-944-6733 FAX: 812-948-5047
e-Mail info@SAMTEC.com code 55322

DESCRIPTION:
EXAMAX™ RIGHT ANGLE RECEPTACLE ASSEMBLY

DWG. NO.
EBTF-4-XX-2.0-X-RA-X-X-X

BY: ROY LUO 10/03/2014 SHEET 4 OF 5

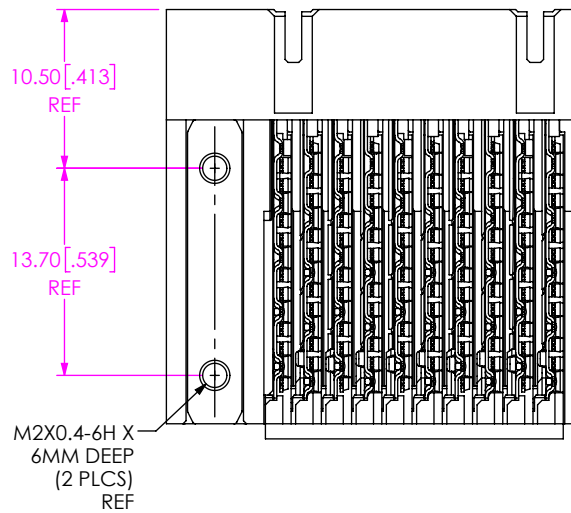
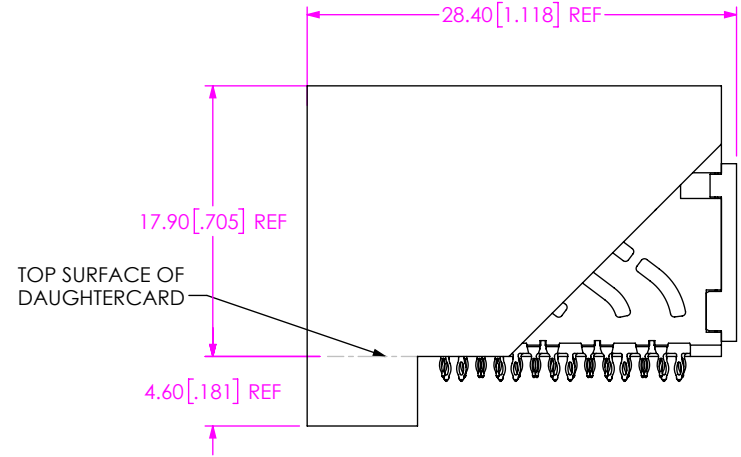
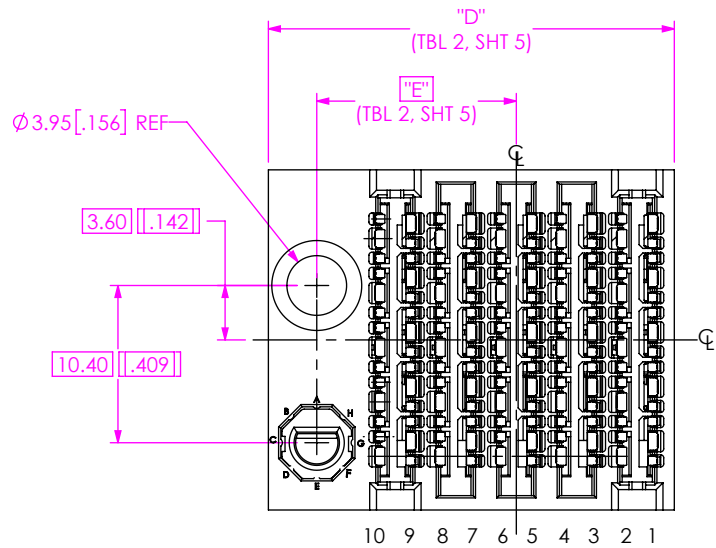

FIG 6
LEFT GUIDANCE
EBTF-4-10-2.0-X-RA-X-L-A SHOWN
(DIFFERENT AS SHOWN, OTHERWISE SAME AS FIG 5)

PROPRIETARY NOTE
THIS DOCUMENT CONTAINS CONFIDENTIAL AND PROPRIETARY INFORMATION AND ALL DESIGN, MANUFACTURING, REPRODUCTION, USE, PATENT RIGHTS AND SALES RIGHTS ARE EXPRESSLY RESERVED BY SAMTEC, INC. THIS DOCUMENT SHALL NOT BE DISCLOSED, IN WHOLE OR PART, TO ANY UNAUTHORIZED PERSON OR ENTITY NOR REPRODUCED, TRANSFERRED OR INCORPORATED IN ANY OTHER PROJECT IN ANY MANNER WITHOUT THE EXPRESS WRITTEN CONSENT OF SAMTEC, INC.

DO NOT SCALE DRAWING

SHEET SCALE: 2:1



520 PARK EAST BLVD, NEW ALBANY, IN 47150
PHONE: 812-944-6733 FAX: 812-948-5047
e-Mail info@SAMTEC.com code 55322

DESCRIPTION:
EXAMAX™ RIGHT ANGLE RECEPTACLE ASSEMBLY

DWG. NO.
EBTF-4-XX-2.0-X-RA-X-X-X

BY: ROY LUO 10/03/2014 SHEET 5 OF 5