

PAM2861EV Board User Guide

AE Department

1. Revision Information

Date	Revision	Description	Comment
2008/8/18	V1.0	Initial Release	

2. EV Board Schematic

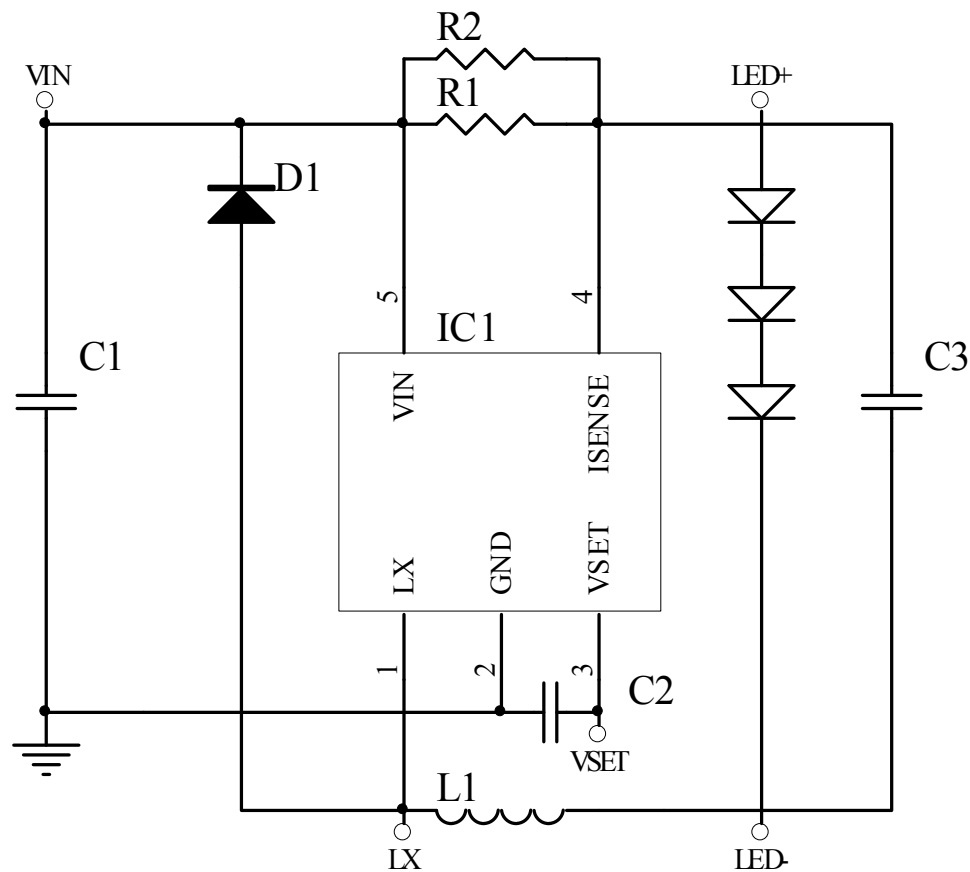

3. EVB PAM2861 EB86AB Description

PAM2861 EB86AB is an evaluation board for the PAM2861/2 (SOT-23-5 package), a high power LED buck driver. The board is targeted to be used in providing a simple and convenient evaluation environment for the PAM2861/2. Efficiency on the board make it easy to be evaluated.

Use single power supply to drive 1-10 serials (PAM2861) or 1-6 serials (PAM2862) 1W or 3W power LED.

4. EV Board View

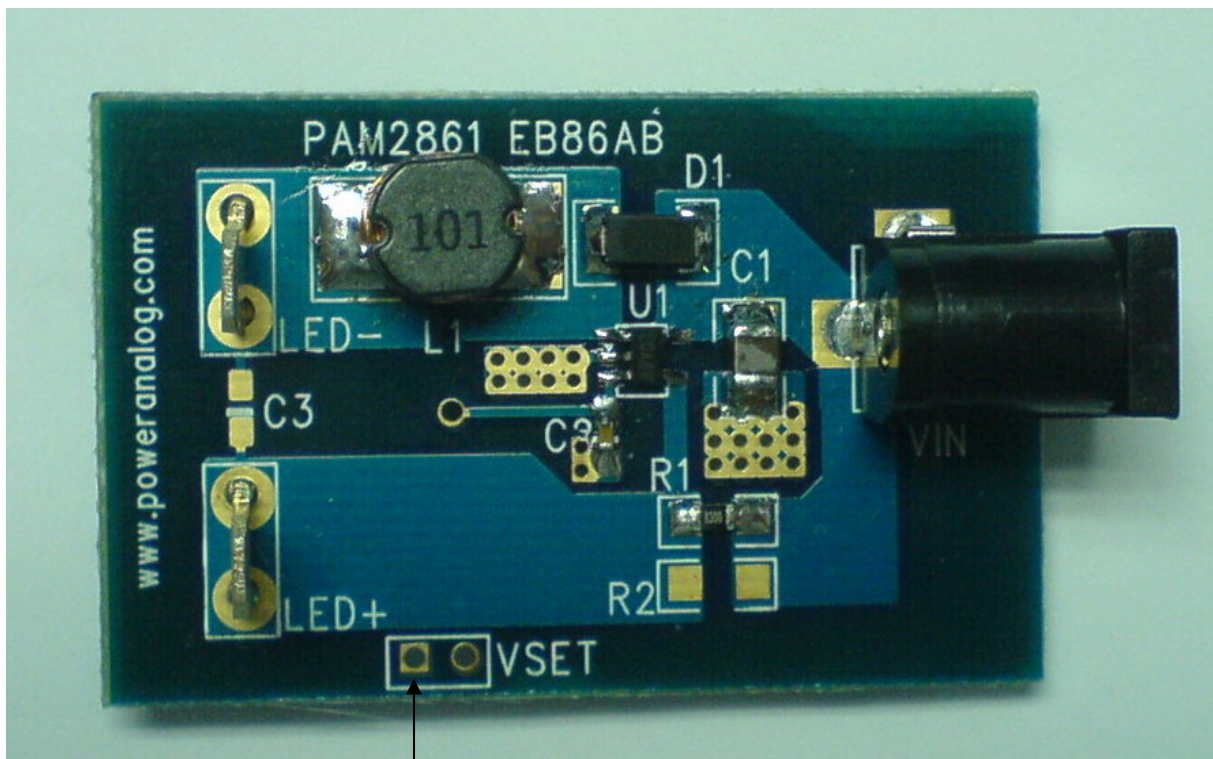

Control signal

EV board operational sequence:

- a. Connect power supply to Vin, (PAM2861 up to 40V, PAM2862 up to 24V).
- b. Connect LED- to power LED cathode and LED+ to power LED anode.
- c. Connect control signal to VSET if need external control, 0.4-2.5VDC voltage for analog dimming or <500Hz PWM signal for PWM dimming.

5. EV Board BOM List

Item	Value	Type	Rating	Description	Vender and Part No.
C1	10 μ F	X5R/X7R, Ceramic/1206	25V	Input coupling CAP	Torch TMK316BJ106KL-T
C2	10nF	X5R/X7R, Ceramic/0603	50V	comp CAP	Murata GRM188R71H103K
C3	NC				
L1	100 μ H	SDR75	0.7A	Inductor	Wurth WE-PD2 type L 74477520 100uH
D1	SS14	SMA	1A/40V	Schottky Diode	SS14
R1	0.3 Ω	0805	1%	Iset Resistor	
IC1	PAM2861/2	SOT-23-5		Power management IC	PAM2861/2
PCB		PAM2861 EB86AB			

6. External Components Selection

Input Capacitors (C1) and Output Capacitor (C3)

- (1) C1 Low ESR needed, 10uF, X5R/X7R ceramic recommended
- (2) C3 can not used.

Soft start Capacitors (C2)

- (1) This capacitor is to increase soft start, 10nF for 1.5mS.
- (2) The capacitor can not use in normal application.

Iset Resistors (R1)

- (1) R set the power LED current , $I_{LED}=0.1V/R$ $R=R1//R2$.
- (2) R, 0.3 Ω \pm 1% for 1W LED (about 333mA).
- (3) R, 0.143 Ω \pm 1% for 3W LED (about 700mA).

Inductor (L1)

- (1) Low DCR needed, 100uH (rating 0.7A) recommended for 1W LED.
- (2) Low DCR needed, 47uH (rating 1.2A) recommended for 3W LED.

Schottky Diode (D1,D2,D3,D4,D5)

- (1) SS14 (1A, 40V) recommended.
- (2) B140 (1A, 40V) recommended.

7. PCB Layout Guidelines

- (1) Connect L1, LX, D1 with short and wide connections. Minimize the switching circuit area to avoid unexpected radiation.
- (2) Place the Iset resistor R1,R2 as close to the sense pin as possible.
- (3) Make sure the current flow path has a wide trace. When current path need vias, use the multiple vias to decrease impedance.
- (4) PAM2861/2 integrate the power MOSFET. Make sure the heat dissipation area is large enough and have a low thermal resistance to atmosphere.

8. PCB Layout Example

Top Layer

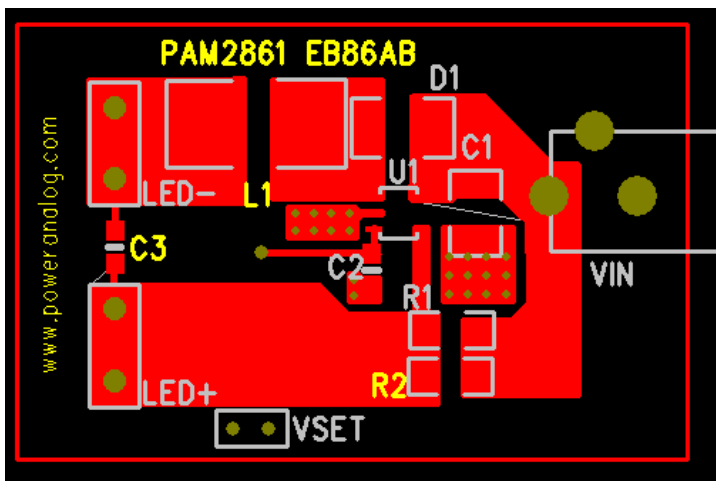

Bottom Layer

