

REVISIONS			
LTR	DESCRIPTION	DATE	APPROVED
B	REVISED PER ECN# T-21394	4/10/97	Z. TEMAN
C	REVISED PER ECN# T-21730	9/19/97	Z. TEMAN

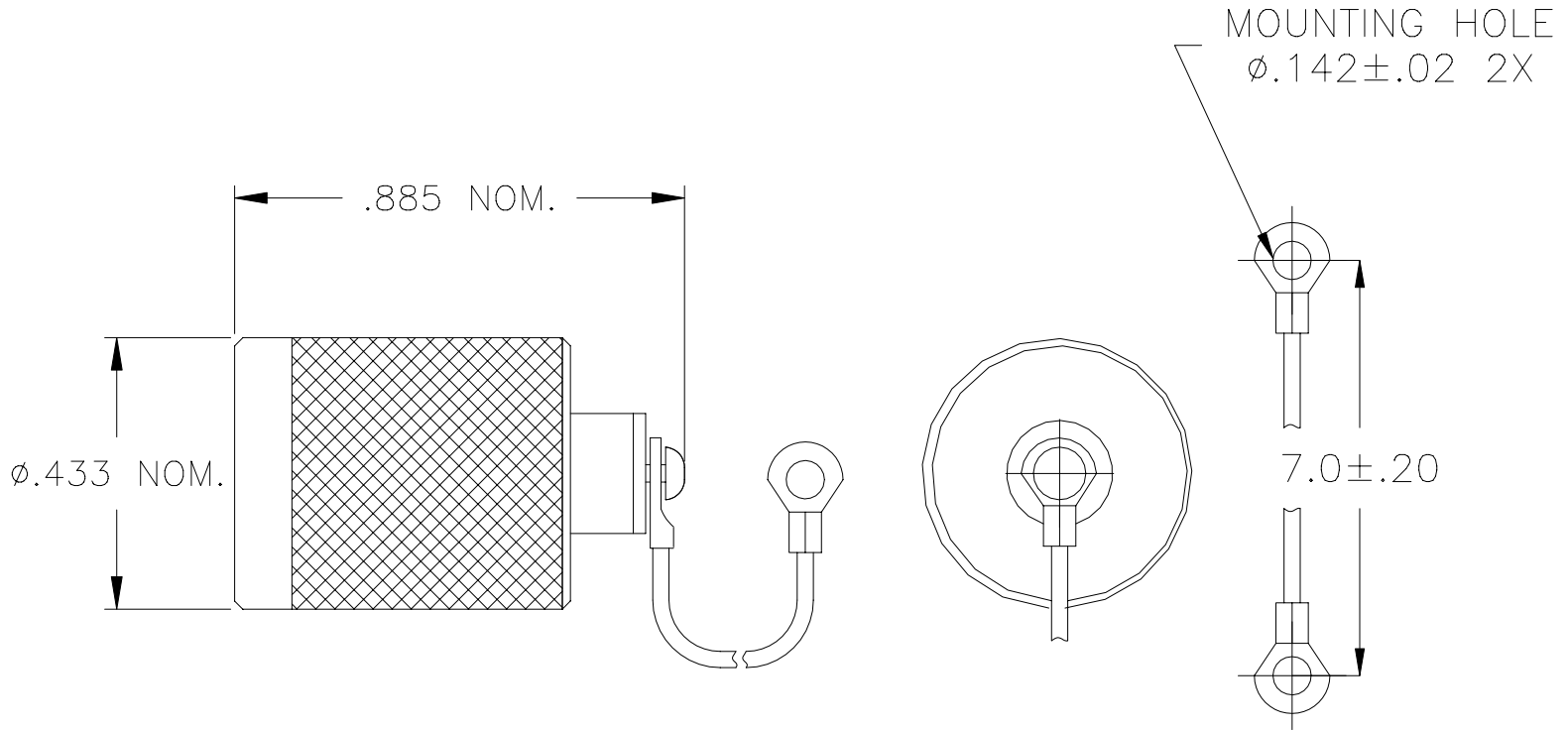

NOTE:
THIS DUST CAP IS TO BE USED ON A 5/16-32 THREADED INTERFACE CONNECTOR.

1.0 MATERIALS AND FINISHES

1.1 DUST CAP COUPLING NUT: BRASS ALLOY 360, HALF HARD PER ASTM B 16.
TIN PLATED PER MIL-T-10727, OVER NICKEL PER QQ-N-290.

1.2 INTERFACIAL SEAL: SILICONE RUBBER

1.3 SCREW AND LANYARD: STAINLESS STEEL, PASSIVATED PER QQ-P-35.

If this document is printed it becomes uncontrolled.
Check for the latest revision.

SPECIFICATION CONTROL DRAWING

UNLESS OTHERWISE SPECIFIED DIMENSIONS ARE IN INCHES. METRIC DIMENSIONS ARE IN BRACKETS. DECIMALS .XXX ± — [— mm] .XX ± — [— mm] ANGLES .X ± — WEIGHT — lbs [— g]	DRAWN	ZET	2/20/97		Tyco Electronics Corporation 300 Constitution Drive Menlo Park, CA. 94025 U.S.A.		
	CHECKED						
	APPROVED			TITLE	DUST CAP, THREADED, COUPLED,		
	APPROVED	P.DUTTON		CAD NAME			
THIRD ANGLE PROJECTION				SIZE	CODE IDENT. NO.	DWG. NO.	REV
				A	06090	D-600-0083	C
DO NOT SCALE THIS DRAWING				SHEET 1 OF 1			