

10 9 8 7 6 5 4 3 2 1

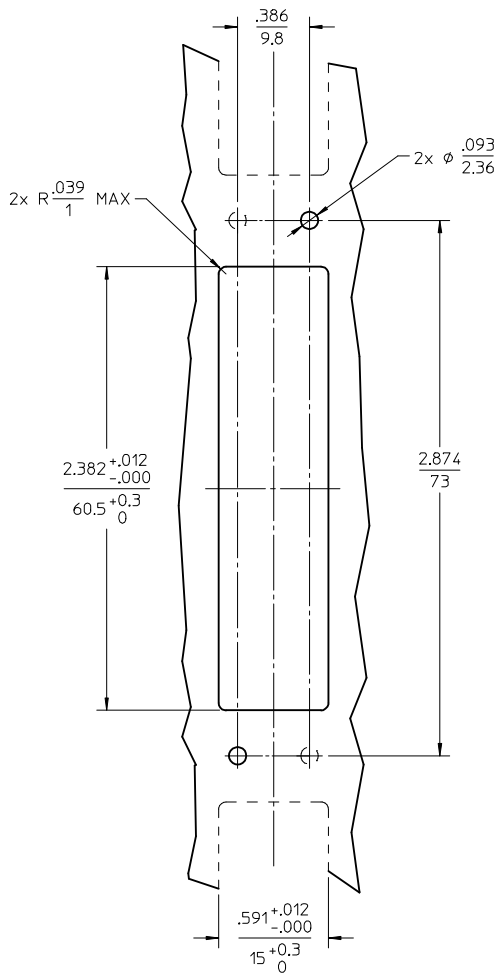

PANEL CUTOUT

NOTES:

- PART IS SUPPLIED WITH PRESS FIT NUT (#2-56 THREADS) AND TWO (2) SILICONE GASKET WITH CONDUCTIVE FILLER (SHOWN COMPRESSED).
- OUTER SHELL OF PART IS DIECAST.
- DUST CAPS SHOWN IN ISOMETRIC VIEW ONLY.

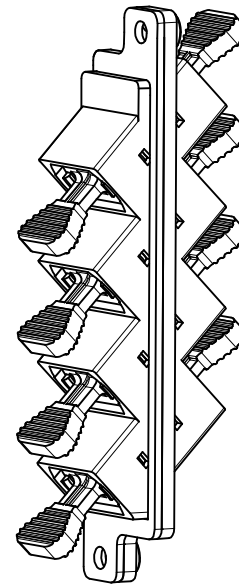
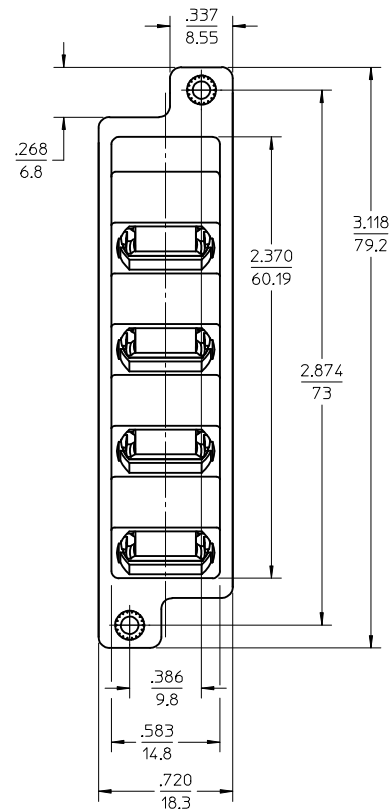
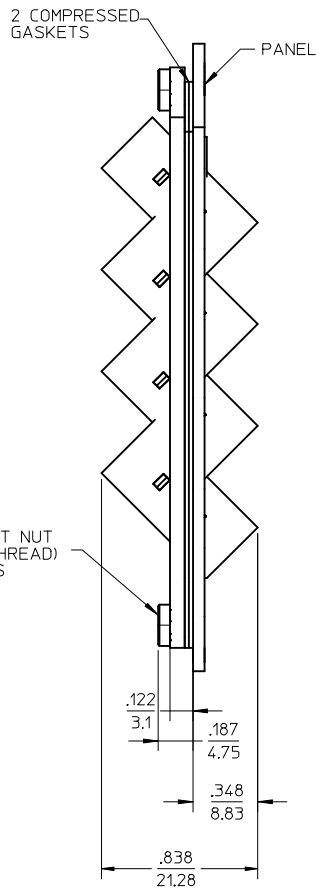

ENTER DESCRIPTION EC NO: MF2013-0264 DRW:KPEVZNER 2012/11/09 CHKD: APPR: IGUMIN 2012/11/09 A1	QUALITY SYMBOLS F/0 F/0 F/0	GENERAL TOLERANCES (UNLESS SPECIFIED) mm INCH 4 PLACES ± --- ± --- 3 PLACES ± --- ± --- 2 PLACES ± 0.10 ± --- 1 PLACE ± 0.10 ± --- 0 PLACE ± --- ± ---	DIMENSION STYLE INCH ONLY DRAWN BY DATE J.SZ. 2008/11/17 CHECKED BY DATE APPROVED BY DATE I.G. 2008/02/06	SCALE 1.5:1 DESIGN UNITS INCH THIRD ANGLE PROJECTION	TITLE MPO EMI ADAPTER QUAD, 45 DEGREE
	ANGULAR ±1/2° DRAFT WHERE APPLICABLE MUST REMAIN WITHIN DIMENSIONS		MATERIAL NO. 1061149501	DOCUMENT NO. SD-106114-9501	SHEET NO. 1 OF 1
	THIS DRAWING CONTAINS INFORMATION THAT IS PROPRIETARY TO MOLEX INCORPORATED AND SHOULD NOT BE USED WITHOUT WRITTEN PERMISSION				
	molex				

9 8 7 6 5 4 3 2 1