

10 9 8 7 6 5 4 3 2 1

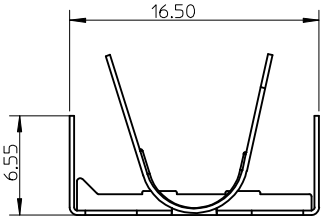
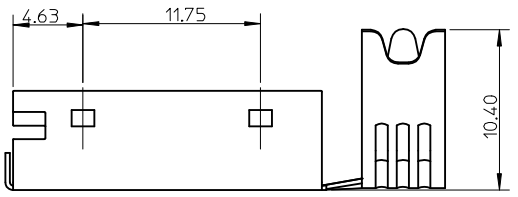
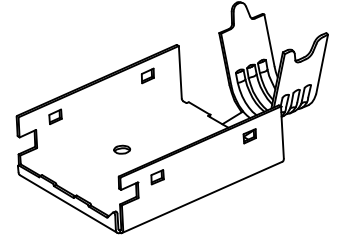
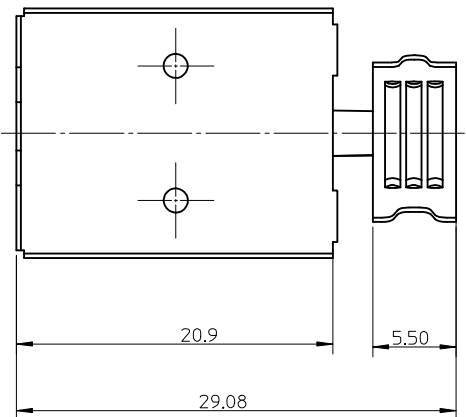

- NOTES:
 1. MATERIAL : 0.30 THICKNESS YELLOW BRASS.
 2. PLATING : NICKEL 2.0 MICROMETER MIN OVERALL.

NEW RELEASE EC NO: SH2007-0705 DRWN: HHE 2007/04/27 CHKD: HWANG 2007/04/30 APPR: JNCHEN 2007/05/10	DESCRIPTION REV	QUALITY SYMBOLS	GENERAL TOLERANCES (UNLESS SPECIFIED)	DIMENSION STYLE	SCALE	DESIGN UNITS	THIRD ANGLE PROJECTION	
		$\nabla=0$ $\text{C}=0$	mm INCH 4 PLACES ± --- ± --- 3 PLACES ± --- ± --- 2 PLACES ± 0.2 ± --- 1 PLACE ± 0.2 ± --- ANGULAR ± ---°	MM ONLY	3:1	METRIC	DRAWN BY: QWFANG DATE: 2006/09/05 CHECKED BY: IWANG DATE: 2006/09/05 APPROVED BY: JNCHEN DATE: 2006/09/05	TITLE
			DRAFT WHERE APPLICABLE MUST REMAIN WITHIN DIMENSIONS	MATERIAL NO.	DOCUMENT NO.	INNER-SHELL-LOWER FOR DISPLAYPORT MOLEX INCORPORATED		SHEET NO.
		A		47271-1009	SD-47271-009	THIS DRAWING CONTAINS INFORMATION THAT IS PROPRIETARY TO MOLEX INCORPORATED AND SHOULD NOT BE USED WITHOUT WRITTEN PERMISSION		1 OF 1

9 8 7 6 5 4 3 2 1