

APPLICATIONS

- Optical Sensors
- RGB Light Sources
- Color Separation for Process Control
- Medical Instruments
- Analog and Digital Data Links
- Robotics Communications
- Display Indicators
- Electronic Games
- Wavelength Multiplexing
- Fluorescent Instruments

DESCRIPTION

The IF-E92A and IF-E92B are blue LEDs housed in a “connector-less” style plastic fiber optic package. The IF-E92A contains a Silicon Carbide die with a spectral output peaking at 430 nm and the IF-E92B die is made from Gallium Nitride peaking at 470 nm. The device package features an internal micro-lens and a precision-molded PBT housing to ensure efficient optical coupling with standard 1000 μm core plastic fiber cable.

APPLICATION HIGHLIGHTS

These LEDs are low-cost alternatives to other light sources for producing a narrowband blue light output that can be efficiently coupled into a fiber cable. They can be used in a variety of sensor and display applications that require a narrowband optical light source whose intensity can be easily adjusted or modulated without changing optical spectrum. When combined with red and green LEDs the IF-E92A and IF-E92B provide an RGB source for generating white or multicolored light. Applications include process control for color identification/separation and demonstration of wavelength division multiplexing for educational purposes. The IF-E92A and IF-E92B are also capable of digital data rates of 1 Mbps and 5 Mbps respectively. The electrical drive circuit design is the same as that of other LEDs, making the IF-E92A and IF-E92B cost-effective light sources in a variety of analog, digital sensor and lighting applications.

FEATURES

- ◆ Easily Adjusted or Modulated Blue Optical Output
- ◆ Fast Transition Times
- ◆ No Optical Design Required
- ◆ Mates With Standard 1000 μm Core, 2.2 mm Jacketed Plastic Fiber Cable
- ◆ Mates with 2.2 mm Jacketed Multimode Glass Fiber, 200/230 or 400/430 using Active Device Adapter – 51 0537; 51 0538
- ◆ Internal Micro-Lens for Efficient Optical Coupling
- ◆ Inexpensive Plastic Connector Housing
- ◆ Connector-Less Fiber Termination
- ◆ RoHS Compliant

MAXIMUM RATINGS

($T_A=25^\circ\text{C}$)

Operating and Storage Temperature Range (TOP, TSTG) -40° to 60°C
 Junction Temperature (T_J) 85°C
 Soldering Temperature (2 mm from case bottom) (T_S) $t \leq 5\text{s}$ 240°C
 Reverse Voltage (V_R).....5 V
 Power Dissipation (PTOT) $T_A=25^\circ\text{C}$60 mW
 De-rate Above 25°C1.1 mW/ $^\circ\text{C}$
 Forward Current, DC (I_F) ...35 mA
 Surge Current (I_{FSM}) $t \leq 10 \mu\text{s}$ 75 mA

CHARACTERISTICS ($T_A = 25^\circ\text{C}$)

Parameter	Symbol	IF-E92A	IF-E92B	Unit
Typical Values, 25°C ,				
Peak Wavelength	λ_{PEAK}	430	470	nm
Spectral Bandwidth (FWHM)	$\Delta\lambda$	80	30	nm
Output Power Coupled into Plastic Fiber (1 mm core diameter). Distance Lens to Fiber ≤ 0.1 mm, 100 mm polished fiber, $I_F=10$ mA	P_O	80 -11	400 -4	μW dBm
Output Power Coupled into Glass Fiber (200/230 μm core) Distance Lens to Fiber ≤ 0.1 mm, 1 meter BC04265-10 fiber, $I_F=20$ mA	P_O	3.52 -24.54	44.91 -13.48	μW dBm
Fiber Transmission Loss SH4001 10 meter cutback	L	0.15	0.15	dB/m
Switching Times (10% to 90% and 90% to 10%) (Figure 3)	t_r t_f	600 500	35 150	ns ns
Capacitance ($V_F=0$, $F=1$ Mhz)	C_0	75	55	pF
Forward Voltage (10 MA)	V_f	3.7	3.0	V
Temperature Coefficient, λ_{PEAK}	TC_λ	.16	.16	nm/K

CAUTION: The IF E92 is ESD sensitive. To minimize risk of damage observe appropriate precautions during handling and processing.

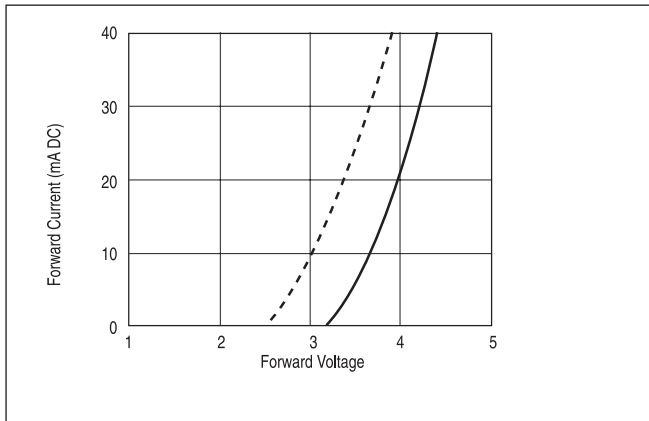

FIGURE 1. Forward current versus forward voltage.

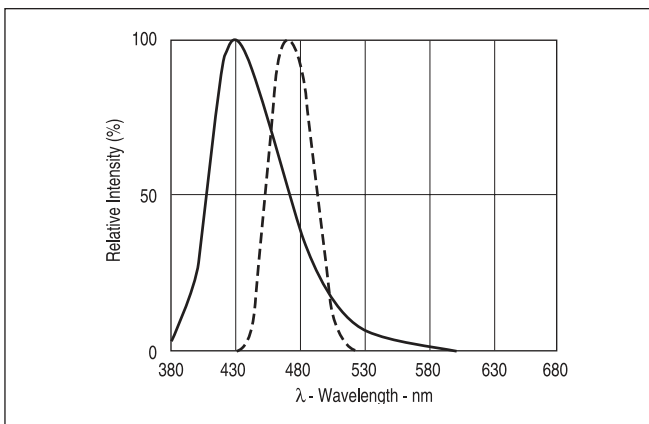

FIGURE 2. Typical spectral output vs. wavelength.

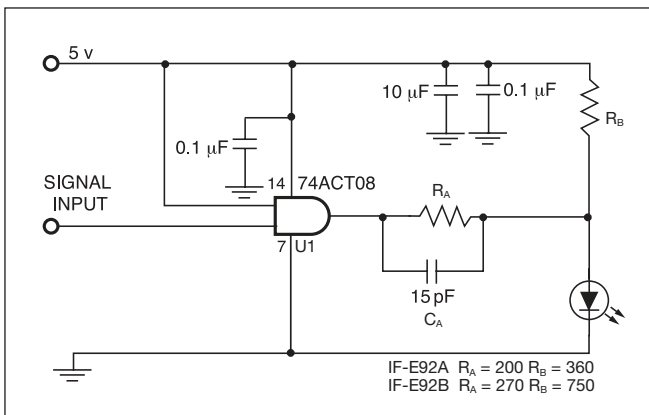

FIGURE 3. Test/Application circuit (IF = 10mA).

APPLICATION NOTES

The application circuit given in Figure 3 can be used to drive the IF-E92 for fast applications. Gate U1 represents the circuit being used to drive the IF-E92. This must be able to supply the desired drive current at the output voltage. Resistor R_A supplies most of the drive current for the IF-E92. The amount of current supplied is $I_A = (V_{U1} - V_f) / R_A$, where V_f is the IF-E92 forward voltage and V_{U1} is the drive circuit's output voltage under load. Resistor R_B speeds up the switching time by keeping the voltage across the IF-E92 from going to zero during turn off. It also supplies some of the drive current. The drive current from R_B is $I_B = (V_{CC} - V_f) / R_B$, where V_{CC} is the supply voltage. The total drive current to the IF-E92 is $I_A + I_B$. Some power is wasted in R_B when the IF-E92 is off. Capacitor C_A is used to increase the drive current during switching and speed up the turn on and turn off times. It must not be so large as to overdrive the IF-E92 during turn on or drive the voltage negative during turn off. For lower speed applications, only R_A is needed and C_A and R_B can be omitted.

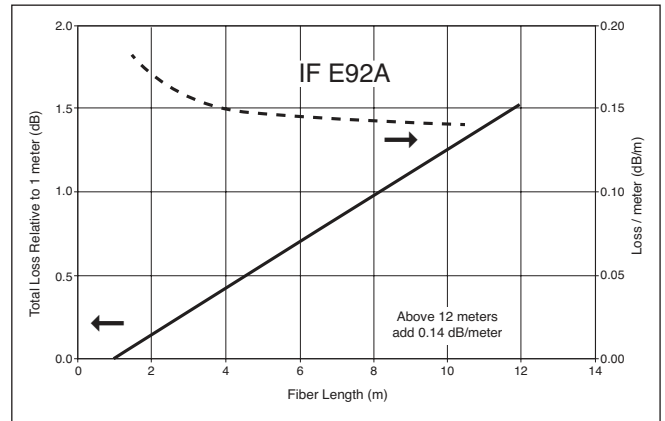

FIGURE 4. Fiber Loss in GH4001

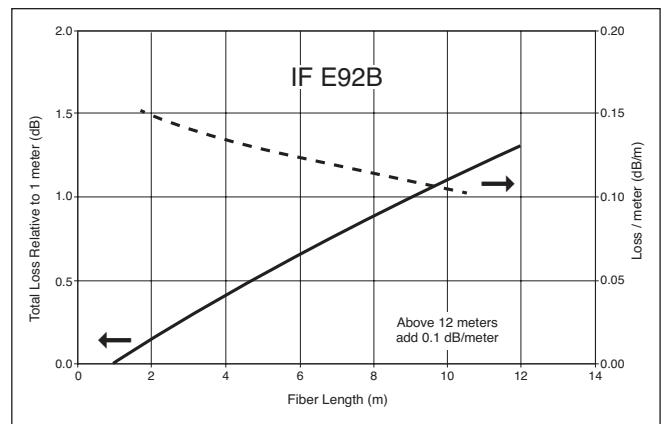

FIGURE 5. Fiber Loss in GH4001

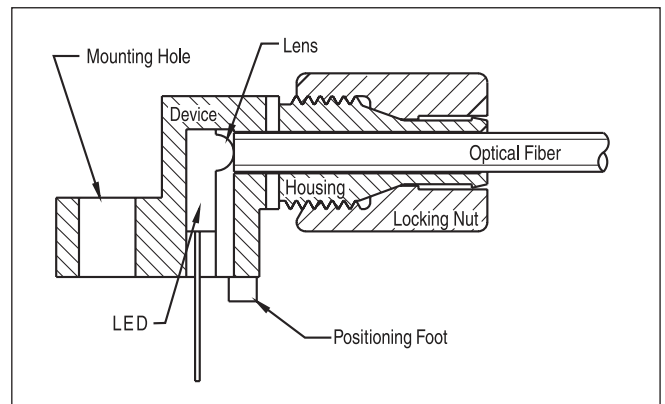

FIGURE 6. Cross-section of fiber optic device.

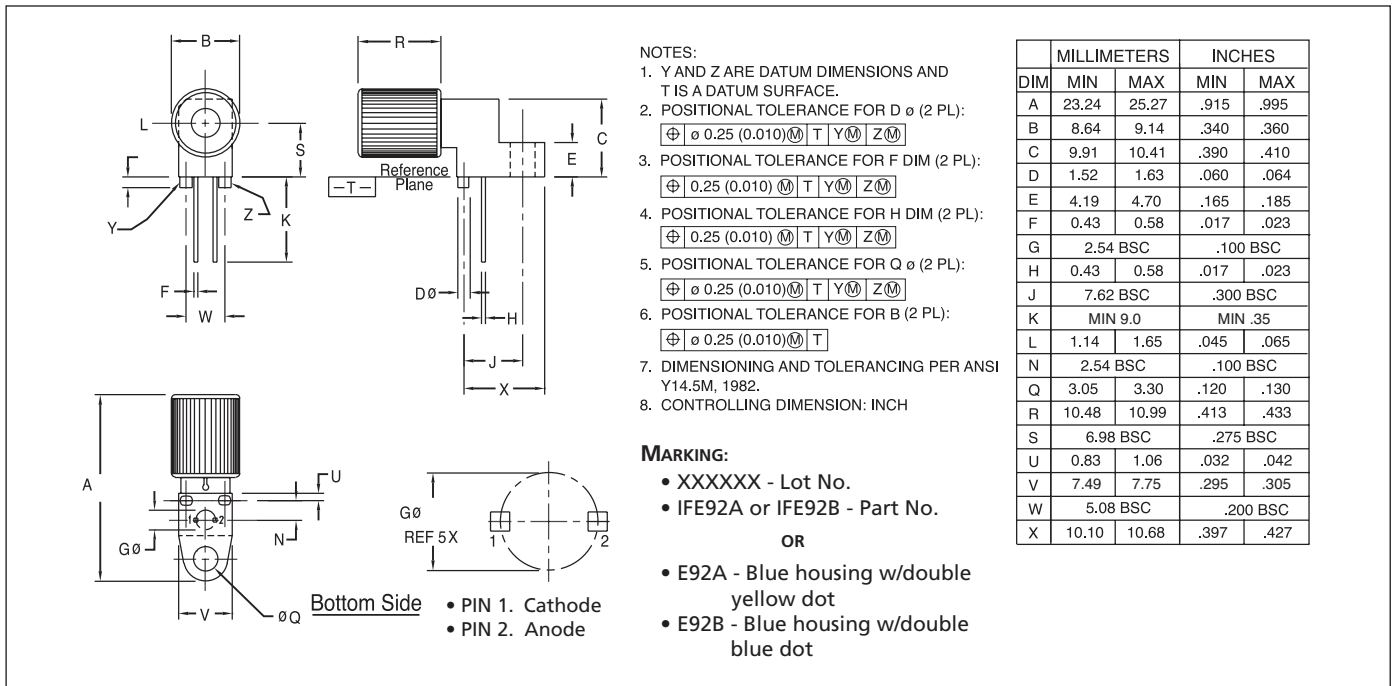

FIGURE 7. Case outline. Specifications are believed to be accurate but are subject to change. Industrial Fiber Optics assumes no responsibility for the consequences of using the information provided beyond replacement warranty for products not meeting stated specifications. Industrial Fiber Optics products are not authorized for use in life support applications without written approval from the President of Industrial Fiber Optics Corporation.

CAUTION:

- To avoid degraded device life due to package stress, do not bend or form leads outside the orientation shown on drawing.
- Ensure that solder flux does not migrate into the device and block the optical path, degrading the performance.
- If washing the device, liquid may become trapped in the part cavity. Ensure that all potentially corrosive materials are flushed out of the device.

FIBER TERMINATION INSTRUCTIONS – PLASTIC OPTICAL FIBER

1. Cut off the ends of the optical fiber with a single-edge razor blade or sharp knife. Try to obtain a precise 90-degree angle (square).
2. Insert the fiber through the locking nut and into the connector until the core tip seats against the internal micro-lens.
3. Screw the connector locking nut down to a snug fit, locking the fiber in place. Do not exceed a torque of 0.4 N·m.

Glass fiber – Refer to instructions listed on manufacturer's data sheet for each active device adapter.