

REVISIONS							
REV	ZONE	ECO	DESCRIPTION	DATE	BY	CHK	APPR
A1	-	-	TECHNICAL DATA SHEET RELEASE	07-OCT-15	JLAG	-	-

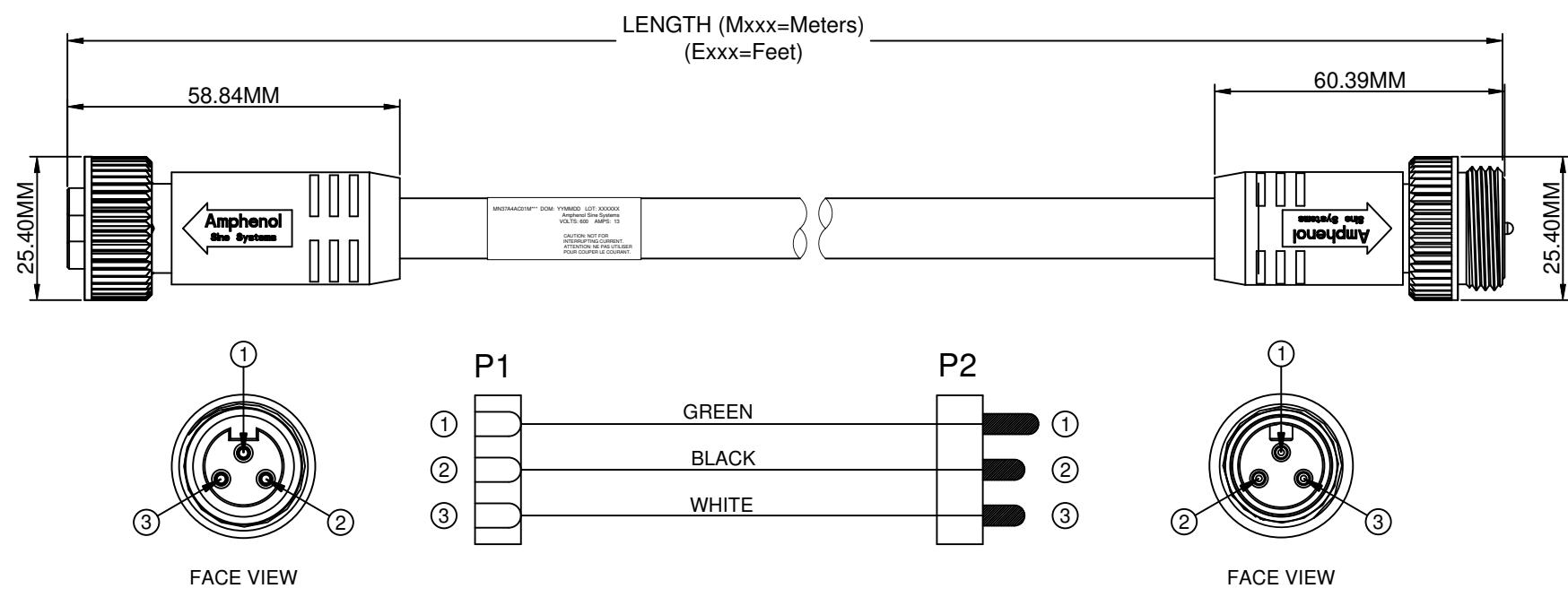

**TECHNICAL DATA:**

**1) MATERIALS:**

- COUPLING NUT: MACHINED ALUMINUM, ANODIZED
- INSULATION INSERT: THERMOPLASTIC, UL 94/V-0
- CONTACT: GOLD FLASH PLATING OVER COPPER ALLOY
- OVERMOLD MATERIAL: THERMOPLASTIC COLOR: YELLOW
- CABLE RATING: UL LISTED TYPE STOOW, CSA CERTIFIED TYPE ST, FT2 FLAME RATING, 600V, 105°C
- CABLE JACKET MATERIAL: PVC COLOR: YELLOW
- CONDUCTOR INSULATION: PVC
- NUMBER OF CONDUCTORS: (3) 16AWG

**2) ELECTRICAL DATA:**

- CURRENT (MAX): 13A
- VOLTAGE (MAX): 600V AC/DC
- INSULATION RESISTANCE (MIN): 5000M OHMS
- DIELECTRIC TEST VOLTAGE: 2200V

**3) MECHANICAL DATA:**

- TEMPERATURE RANGE: -20°C TO +105°C
- PROTECTION: IP67 (MATED CONDITION)
- MATING CYCLES: >500
- VIBRATION RESISTANCE PER MIL-STD-202 METHOD 204
- THERMO SHOCK PER MIL-STD-202 METHOD 207
- 48 HOUR SALT SPRAY PER MIL-STD-202 METHOD 101

- 4) RoHS COMPLIANT
- 5) UL 2238 LISTED ASSEMBLY
- UL FILE NUMBERS: E224856

TOLERANCE	
0-2.99 M = +100.0/-25.0mm	0-9.99 FT = +4" / -1"
3-8.99 M = +150.0/-25.0mm	10.00-29.99 FT = +6" / -1"
9-14.99 M = +300.0/-25.0mm	30.00-49.99 FT = +12" / -1"
15-OVER M = +450.0/-25.0mm	50 FT-OVER = +18" / -1"

Risk of Electrical Shock  
Do Not Disconnect Under Load.  
Risque de chocs électriques  
Ne pas debrancher sous tension.

**WARNING**

QUANTITY	PART NUMBER	DESCRIPTION	ITEM
<b>MATERIALS LIST</b>			
UNLESS OTHERWISE SPECIFIED:		SIGNATURES DATE	
1) All dimensions are in metric (mm).		DRAWN: KMM 12-MAY-14	
2) Tolerances are as follows:		CHECKED: MRF 12-MAY-14	
1 PL DEC ±0.30 Fractions ±1/64		ENGINEER: KMM	
2 PL DEC ±0.15 Angles ±1°		APPROVAL: RFC 12-MAY-14	
3 PL DEC ±0.08		CUSTOMER:	
3) Note reference =		MATERIAL SPECIFICATIONS:	
THIS DRAWING IS SUPPLIED FOR INFORMATION ONLY. DESIGN FEATURES, SPECIFICATIONS AND PERFORMANCE DATA SHOWN HEREON ARE THE PROPERTY OF THE AMPHENOL CORPORATION. NO RIGHTS OF REPRODUCTION ARE IMPLIED. ALL DIMENSIONS ARE SUBJECT TO NORMAL MANUFACTURING VARIATIONS.		CUSTOMER:	
NEXT ASSY:		MATERIAL SPECIFICATIONS:	
		MINIBOSS M22 (7/8"), 3 PIN, MALE INLINE, STRAIGHT TO FEMALE, STRAIGHT, 16 AWG, STOOW, PVC JACKET	
		Sine Systems - www.sineco.com 44724 Morley Drive Clinton Township, MI 48036	
		SCALE: HALF C-MN37A4AC01	
		REVISION: A1	
		SHEET 1 OF 1	

Title: MINIBOSS M22 (7/8"), 3 PIN, MALE INLINE, STRAIGHT TO FEMALE, STRAIGHT, 16 AWG, STOOW, PVC JACKET