



## XR112 Radar Sensor Board Product Brief



XR112 Radar Sensor Board Product Brief

Proprietary and Confidential

Author: Acconeer

Version 2.1: 2021-04-21



# Table of Contents

1	Introduction .....	4
2	XR112 Radar Sensor Board .....	5
2.1	Overview .....	5
2.2	Power.....	5
2.3	Electrical Schematics .....	6
2.4	Bill of Material .....	9
2.5	Pinning.....	10
3	Revision History.....	11
4	Disclaimer .....	12



# 1 Introduction

This document briefly describes the Acconeer XR112 sensor board. It has been designed with the purpose of demonstrating and debugging Acconeer A111 Pulsed Coherent Radar Sensor. XR112 should be used together with the XC112 connector board, connected via a flat, flexible cable. A cable of length 203.2mm (Molex 15020-0175) is included in the XR112 package. This combination is referred to as the XC112-XR112 Evaluation Kit (EVK). The EVK will also require a Raspberry Pi 3 for secure processing and power supply.

For More information please read:

- A111 Data Sheet
- XC112-XR112 User Guide



## 2 XR112 Radar Sensor Board

### 2.1 Overview

Picture below shows the XR112 radar sensor board. The leftmost picture shows the front side of the XR112, with the A111 radar sensor mounted centrally, and the rightmost picture shows the reverse side of the XR112.

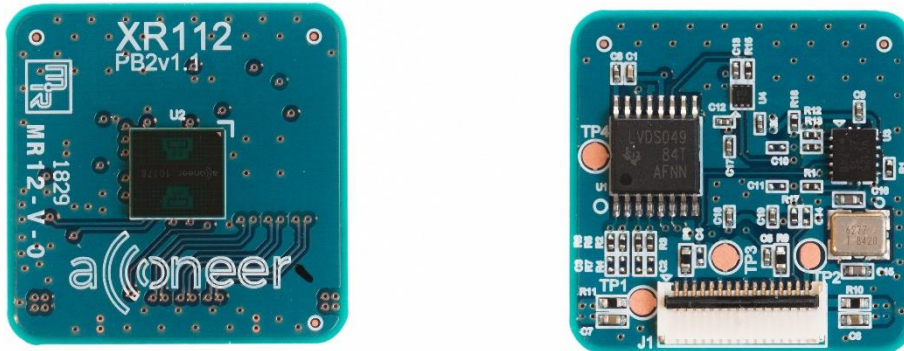

The picture below shows the dimensions of the XR112.

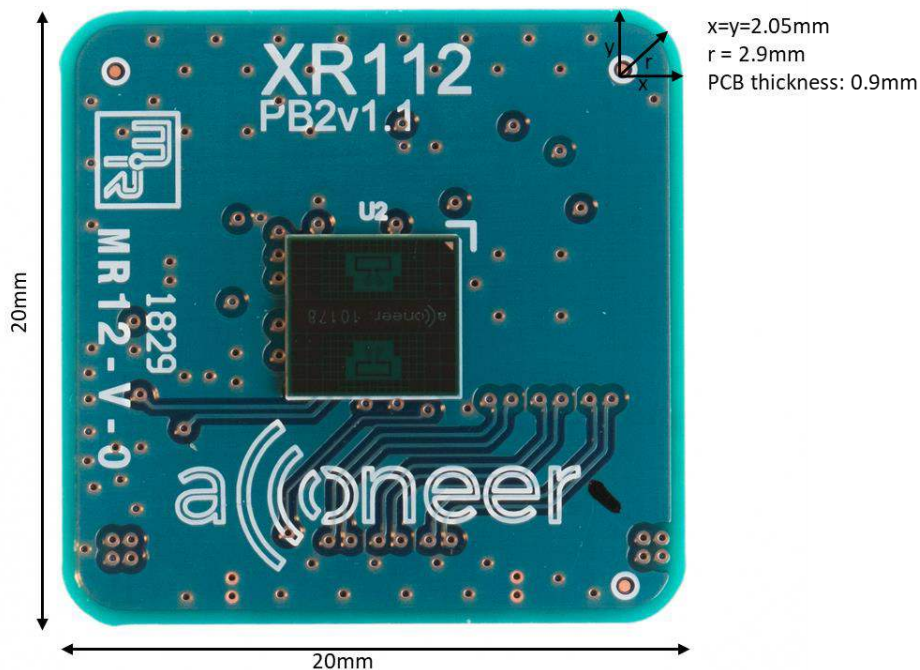

### 2.2 Power

The XC112-XR112 Evaluation Kit is powered through the Raspberry Pi. When the power LED on the Raspberry Pi is lit, the Evaluation Kit is powered on and ready for use.



## 2.3 Electrical Schematics

Below, please find the electrical schematics for the XR112:

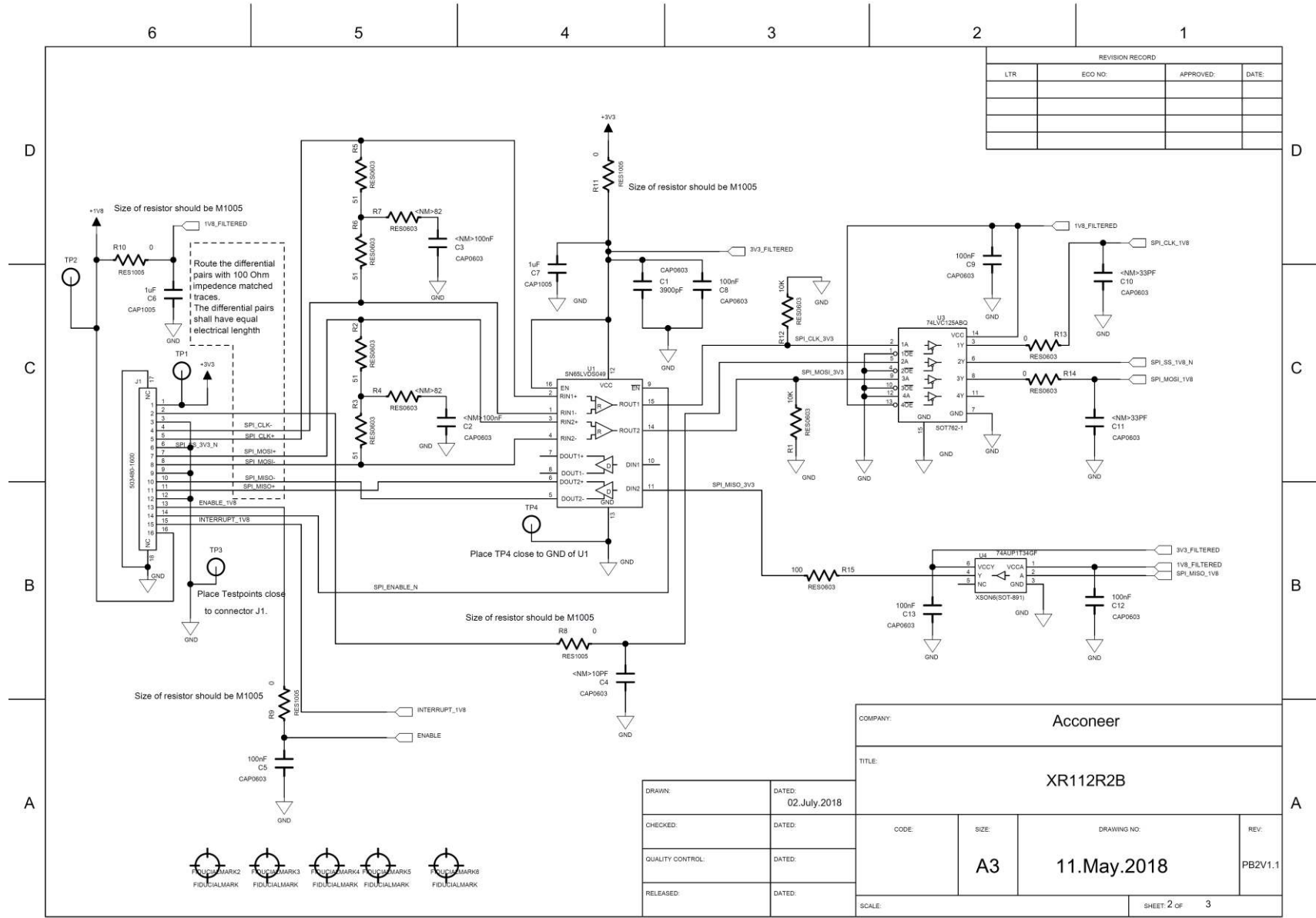

DRAWN:		DATED:		COMPANY:	
CHECKED:		DATED:		Acconeer	
QUALITY CONTROL:		DATED:		TITLE:	
RELEASED:		DATED:		XR112R2B	
CODE:	SIZE:	DRAWING NO:	REV:	A	
	A3	11.May.2018	PB2V1.1		
SCALE:			SHEET 2 OF 3		

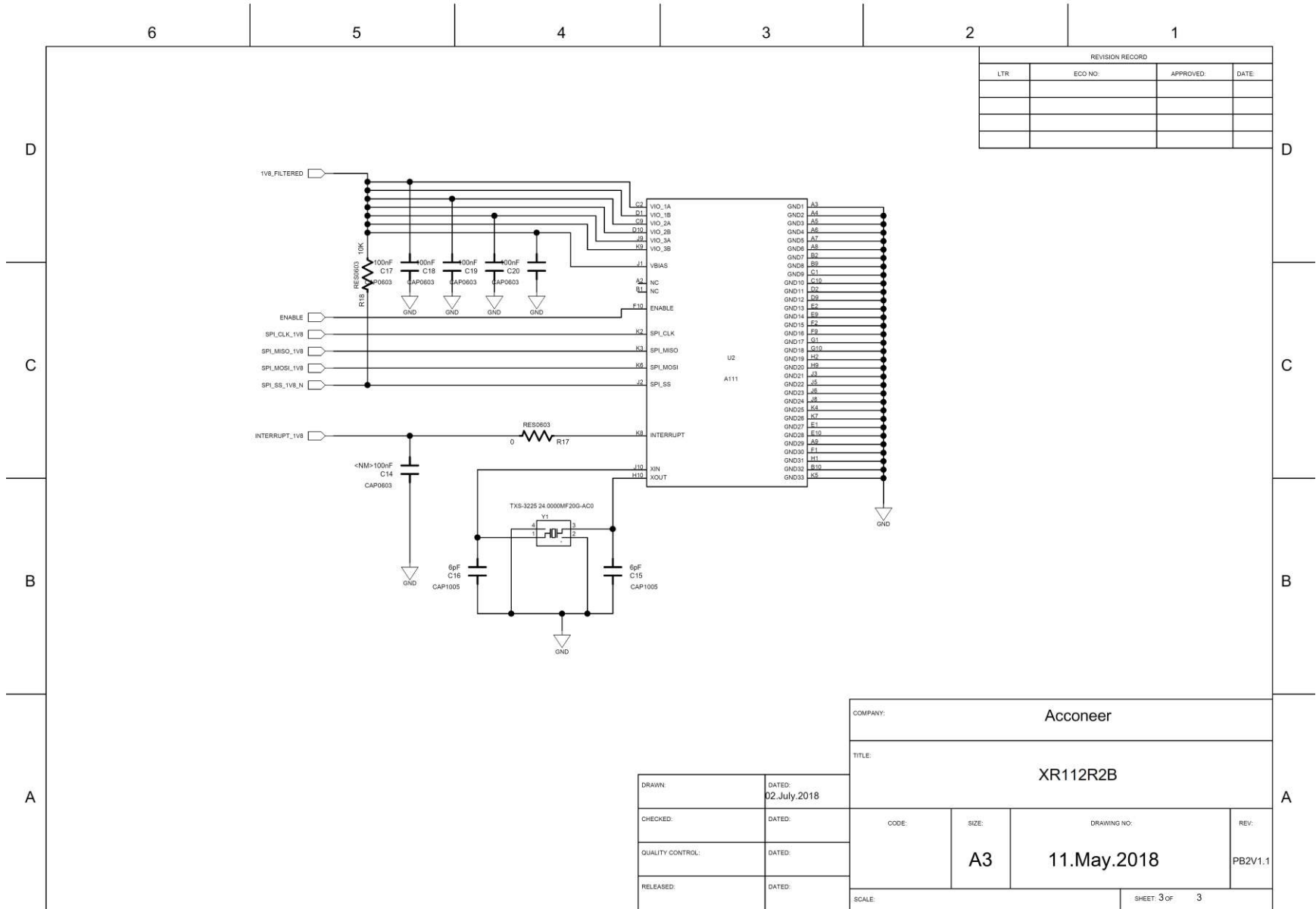





## 2.4 Bill of Material

Table 1 shows the BOM for XR112

Component Ref.	Part Number	QTY	Value	Comment
C1	3.9/NF/K/10V/X5R/0603	1	3900pF	
C12, C13, C17, C18, C19, C20, C5, C8, C9	100/NF/K/6.3V/X5R/0603	9	100nF	
C6, C7	1/UF/K/10V/X5R/1005	2	1uF	
C15, C16	6/PF/C/50V/C0G/1005	2	6pF	
J1	503480-1600	1		16Pin 0.5 FPCB CONN BACKFLIP
R1, R12, R18	10/KOHM/J/0603	3	10kOhm	
R2, R3, R5, R6	51/OHM/F,J/0603	4	50Ohm	
R8, R9, R10, R11	0/OHM/J/1005	4	0Ohm	
R13, R14, R17	0/OHM/J/0603	3	0Ohm	
R15	100/OHM/J/0603	1	100Ohm	
U1	SN65LVDS049PW	1		
U2	A111R2C	1		
U3	74LVC125ABQ	1		
U4	74AUP1T34GF	1		
Y1	EPSON, TSX-3225 24.0000MF20G-AC0	1		24MHz



## 2.5 Pinning

Table 2 shows the PIN connections of XR112.

Pin Number	Description
1	+3.3V
2	SPI_SS_3V3_N, SPI slave select.
3	GND
4	SPI_CLK-
5	SPI_CLK+
6	GND
7	SPI_MOSI+
8	SPI_MOSI-
9	GND
10	SPI_MISO-
11	SPI_MISO+
12	GND
13	ENABLE_1V8, Sensor Enable.
14	SPI_ENABLE_N, Enable signal for differential converter IC.
15	INTERRUPT_1V8, Interrupt from the Sensor.
16	1.8V



### 3 Revision History

<b>Date</b>	<b>Version</b>	<b>Changes</b>
2018-08-14	1.0	Original Version
2018-10-30	1.1	Added picture with XR112 dimensions to chapter 2.1.
2021-04-21	2.1	ISO 14001 update



## 4 Disclaimer

The information herein is believed to be correct as of the date issued. Acconeer AB (“**Acconeer**”) will not be responsible for damages of any nature resulting from the use or reliance upon the information contained herein. Acconeer makes no warranties, expressed or implied, of merchantability or fitness for a particular purpose or course of performance or usage of trade. Therefore, it is the user’s responsibility to thoroughly test the product in their particular application to determine its performance, efficacy and safety. Users should obtain the latest relevant information before placing orders.

Unless Acconeer has explicitly designated an individual Acconeer product as meeting the requirement of a particular industry standard, Acconeer is not responsible for any failure to meet such industry standard requirements.

Unless explicitly stated herein this document Acconeer has not performed any regulatory conformity test. It is the user’s responsibility to assure that necessary regulatory conditions are met and approvals have been obtained when using the product. Regardless of whether the product has passed any conformity test, this document does not constitute any regulatory approval of the user’s product or application using Acconeer’s product.

Nothing contained herein is to be considered as permission or a recommendation to infringe any patent or any other intellectual property right. No license, express or implied, to any intellectual property right is granted by Acconeer herein.

Acconeer reserves the right to at any time correct, change, amend, enhance, modify, and improve this document and/or Acconeer products without notice.

This document supersedes and replaces all information supplied prior to the publication hereof.

