

REVISIONS					
REV	ECO	DESCRIPTION	DATE	BY	APPR
A1	-	RELEASE NEW DRAWING	01/APR/22	MILO	TOMMY

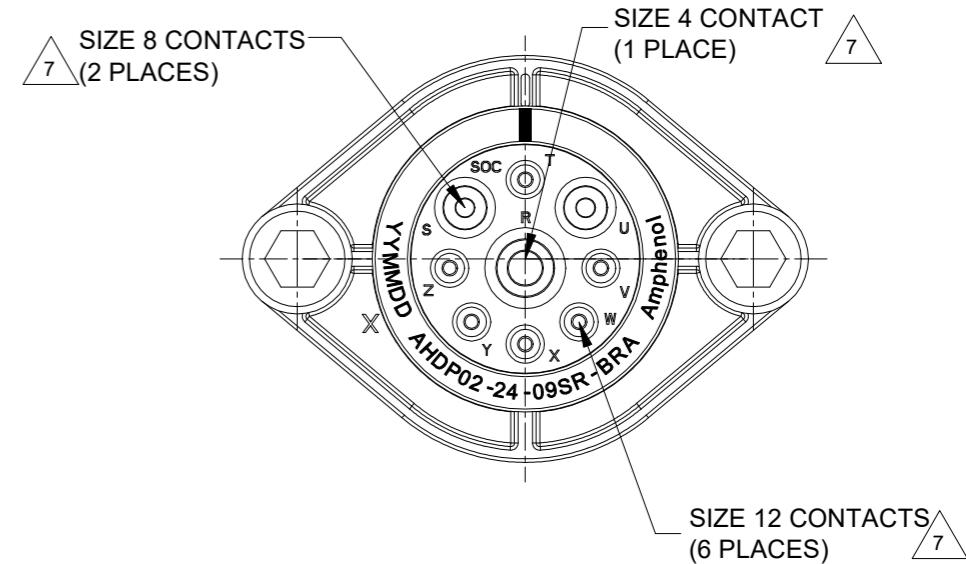

M5X0.8-6H 8mm(2X) DEEP
THREADED INSERT

RECOMMENDED TORQUE
VALUES: 1.9-2.2 N.m

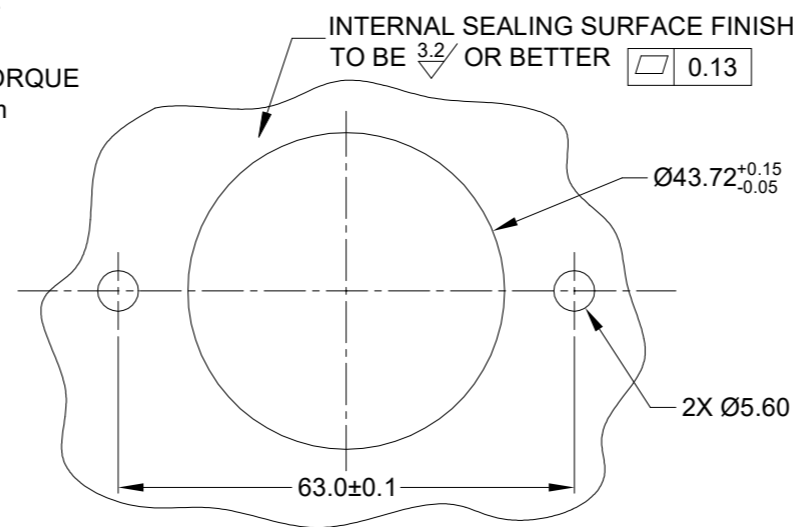

RECOMMENDED PANEL
MOUNTING HOLE

RECOMMENDED PANEL
THICKNESS: 1.6 TO 4.7MM

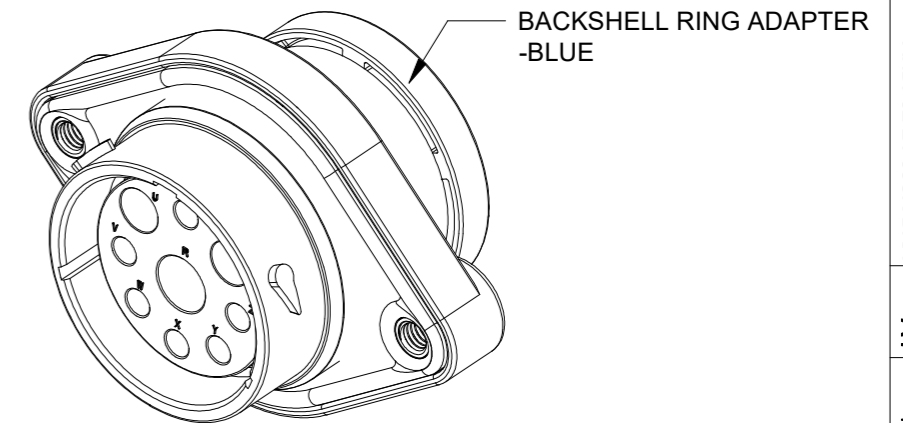

NOTES: UNLESS OTHERWISE SPECIFIED

- MATERIAL:
HOUSING: THERMOPLASTIC; BLACK
SEAL: SILICONE RUBBER
THREADED INSERT: STAINLESS STEEL
- MODIFICATIONS: BACKSHELL RING ADAPTER (BRA);
REDUCED DIA. WIRE SEAL
SEALED PANEL MOUNT
- SPECIFICATIONS:
3.1 OPERATING TEMPERATURE: -55°C TO +125°C.
3.2 DIELECTRIC WITHSTANDING VOLTAGE: LESS THAN 2
MILLIAMPS CURRENT LEAKAGE @ 1500 VOLTS AC.
3.3 INSULATION RESISTANCE: 1000 MEGOHM MIN @ 25°C.
3.4 MOISTURE RESISTANCE:
IP68(IM OF WATER FOR A PERIOD OF 24 HOURS, MATED
CONDITION);
IP69K(MATED CONDITION)
3.5 MATING CYCLE DURABILITY: 100 CYCLES
3.6 RoHS COMPLIANT
- MATING PART: AHDP06-24-09P* (* = SEAL TYPE)
- ALL DIMENSIONS ARE FOR REFERENCE USE ONLY.
- RECEPTACLE IS SUPPLIED WITH DUST CAP (NOT SHOW)

CONTACT SIZE AND WIRE RANGE:

CONTACT SIZE	MIN. INSUL O.D.	MAX. INSUL O.D.	TYPICAL WIRE RANGE	CURRENT RATING
4	6.63 mm (.261 in)	7.42 mm (.292 in)	6 AWG (16.0-13.0mm ²)	100 AMPS
8	3.43 mm (.135in)	5.59 mm (.220 in)	8-10 AWG (10.0-5.0mm ²)	60 AMPS
12	2.46 mm (.097 in)	4.01 mm (.158 in)	10-14 AWG (6.0-2.0mm ²)	25 AMPS

QUANTITY	AHDP02-24-09SR-BRA	DESCRIPTION	ITEM
MATERIALS LIST			
UNLESS OTHERWISE SPECIFIED		SIGNATURES DATE	
1) All dimensions are in metric(mm).		DRAWN: MILO 01/APR/22	
2) Tolerances are as follows:		CHECKED: SULLEN 02/APR/22	
1 PL DEC ±0.30		ENGINEER:	
2 PL DEC ±0.15		APPROVAL: TOMMY 06/APR/22	
3 PL DEC ±0.08		CUSTOMER:	
3) Note reference = X		THIS DRAWING IS SUPPLIED FOR INFORMATION ONLY. DESIGN FEATURES, SPECIFICATIONS AND PERFORMANCE DATA SHOWN HEREON ARE THE PROPERTY OF THE AMPHENOL CORPORATION. NO RIGHTS OF REPRODUCTION ARE IMPLIED. ALL DIMENSIONS ARE SUBJECT TO NORMAL MANUFACTURING VARIATIONS.	
MATERIAL SPECIFICATIONS:		WEIGHT: 66.4g	
PROCESS SPECIFICATIONS:		SCALE: NONE	
NEXT ASSY:		DURAMATE	
		SHEET 1 OF 1	

TITLE: 9 POS RECEPTACLE SOCKET, PANELMATE AHDP SIZE 24, RD SEAL, BRA

DWG NO: AHDP02-24-09SR-BRA

REV: A1

SH: 1

OF: 1

Amphenol

Sine Systems - www.amphenol-sine.com
44724 Morley Drive
Clinton Township, MI 48036

9 POS, RECEPTACLE, SOCKET, PANELMATE
AHDP SIZE 24, RD SEAL, BRA

SIZE B C- DWG NO: AHDP02-24-09SR-BRA REVISION A1