

This document is the property of Amphenol Corporation and is delivered on the express condition that it is not to be disclosed, reproduced or used, in whole or in part, for manufacture or sale by anyone other than Amphenol Corporation without its prior consent, & that no right is granted to disclose or to use any information in this document.

CUSTOMER DRAWING

REVISIONS

SYM	ECN	DESCRIPTION	DATE	APPROVED
1	***	FIRST RELEASE	2020/08/07	Michael.lip
2	***	Dimensional tolerance modification	2020/08/14	Michael.lip
3	***	Iron shell modification	2020/08/20	Michael.lip
4	***	Iron shell modification	2020/08/21	Michael.lip
5	***	Iron shell modification	2020/08/24	Michael.lip
6	***	Update dimensioning	2020/08/26	Michael.lip

Date Code:
YY MM DD
DATE
MONTH
YEAR

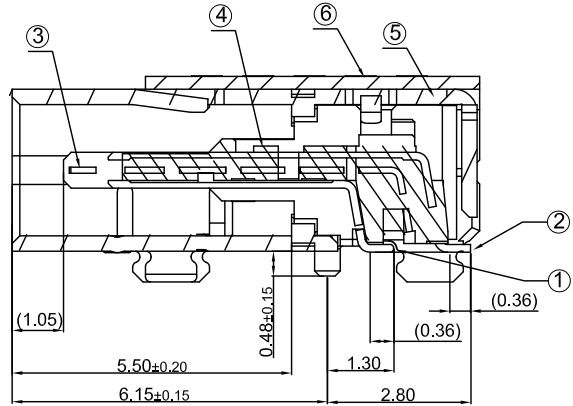
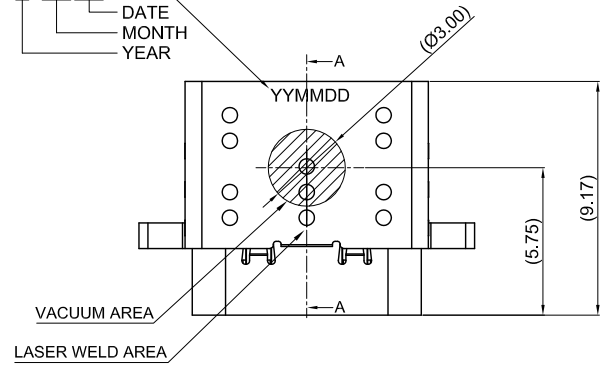

SECTION A-A(剖视图A-A)
SCALE 2:1 (比例 2:1)

Pin定义:

A1	A2	A3	A4	A5	A6	A7	A8	A9	A10	A11	A12
GND	TX1+	TX1-	Vbus	CC1	D+	D-	SBU1	Vbus	RX2-	RX2+	GND
B12	B11	B10	B9	B8	B7	B6	B5	B4	B3	B2	B1

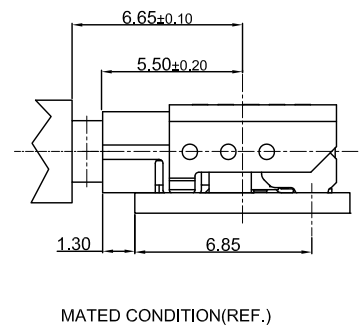
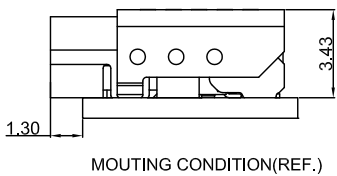
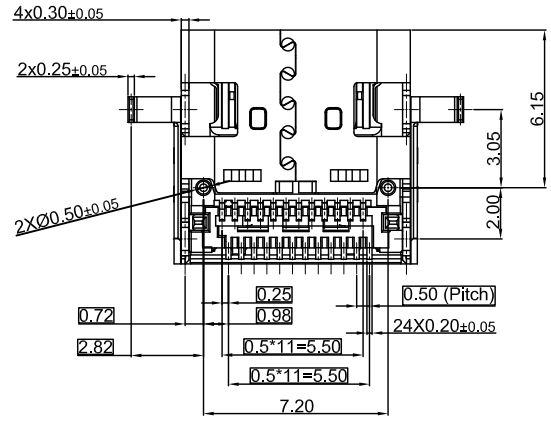
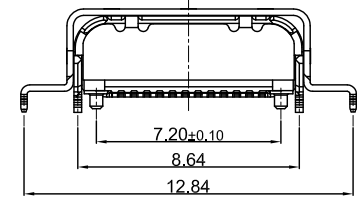
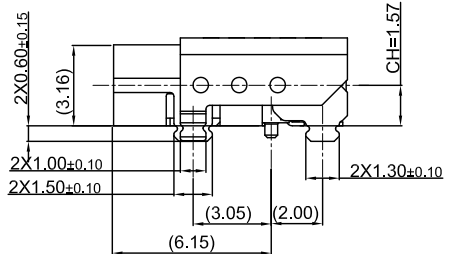
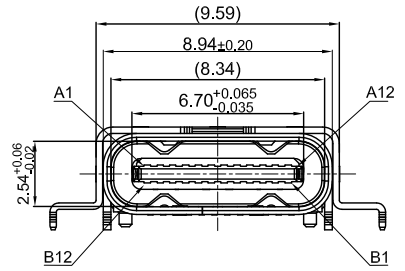

ITEM	DESCRIPTION	QTY	MATERIAL	FINISH	REMARK
6	OUT SHELL	1	STAINLESS STEEL	NICKEL PLATING	
5	INT SHELL	1	STAINLESS STEEL	NICKEL PLATING	
4	MAIN HOUSING	1	HIGH TEMPERATURE	-	COLOR:BLACK
3	MID PLATE	1	STAINLESS STEEL	-	
2	BOTTOM TERMINAL	1	COPPER ALLOY	MATING SIDE:GOLD FLASH; SOLDER TAIL:GOLD FLASH, 30μ" NICKEL OVERALL.	
1	TOP TERMINAL	1	COPPER ALLOY	MATING SIDE:GOLD FLASH; SOLDER TAIL:GOLD FLASH, 30μ" NICKEL OVERALL.	

UNLESS OTHERWISE SPECIFIED TOLERANCES		APPROVAL		DATE	
U.S.	METRIC	DRAWN	Fel.Wu	08/07/20	
±.XX	±/-.050	CHECKED	Michael.Qin	08/07/20	
.XX	±/-.025	CHECKED	Michael.Qin		
FRACTIONS	±/-.010	DRAWING FILE :			
ANGLES	±/-.3°	ANGLE OF PROJECTION			
FOR MATERIALS AND FINISHES SEE NOTES		REMOVE SHARP EDGES			
DIMENSIONS		U.S. INCHES			
(METRIC)		(MM)			
		TITLE Customer Drawing For			
		USB Type C 4.0 socket connector, R/A , Top mount, Double SMT type, CH=1.57mm, No Water proof			
		SIZE DRAWING NO. A3 C 12402073			
		SCALE NONE SHEET 1 OF 2			

