

To our customers,

Old Company Name in Catalogs and Other Documents

On April 1st, 2010, NEC Electronics Corporation merged with Renesas Technology Corporation, and Renesas Electronics Corporation took over all the business of both companies. Therefore, although the old company name remains in this document, it is a valid Renesas Electronics document. We appreciate your understanding.

Renesas Electronics website: <http://www.renesas.com>

April 1st, 2010
Renesas Electronics Corporation

Issued by: Renesas Electronics Corporation (<http://www.renesas.com>)

Send any inquiries to <http://www.renesas.com/inquiry>.

Notice

1. All information included in this document is current as of the date this document is issued. Such information, however, is subject to change without any prior notice. Before purchasing or using any Renesas Electronics products listed herein, please confirm the latest product information with a Renesas Electronics sales office. Also, please pay regular and careful attention to additional and different information to be disclosed by Renesas Electronics such as that disclosed through our website.
2. Renesas Electronics does not assume any liability for infringement of patents, copyrights, or other intellectual property rights of third parties by or arising from the use of Renesas Electronics products or technical information described in this document. No license, express, implied or otherwise, is granted hereby under any patents, copyrights or other intellectual property rights of Renesas Electronics or others.
3. You should not alter, modify, copy, or otherwise misappropriate any Renesas Electronics product, whether in whole or in part.
4. Descriptions of circuits, software and other related information in this document are provided only to illustrate the operation of semiconductor products and application examples. You are fully responsible for the incorporation of these circuits, software, and information in the design of your equipment. Renesas Electronics assumes no responsibility for any losses incurred by you or third parties arising from the use of these circuits, software, or information.
5. When exporting the products or technology described in this document, you should comply with the applicable export control laws and regulations and follow the procedures required by such laws and regulations. You should not use Renesas Electronics products or the technology described in this document for any purpose relating to military applications or use by the military, including but not limited to the development of weapons of mass destruction. Renesas Electronics products and technology may not be used for or incorporated into any products or systems whose manufacture, use, or sale is prohibited under any applicable domestic or foreign laws or regulations.
6. Renesas Electronics has used reasonable care in preparing the information included in this document, but Renesas Electronics does not warrant that such information is error free. Renesas Electronics assumes no liability whatsoever for any damages incurred by you resulting from errors in or omissions from the information included herein.
7. Renesas Electronics products are classified according to the following three quality grades: "Standard", "High Quality", and "Specific". The recommended applications for each Renesas Electronics product depends on the product's quality grade, as indicated below. You must check the quality grade of each Renesas Electronics product before using it in a particular application. You may not use any Renesas Electronics product for any application categorized as "Specific" without the prior written consent of Renesas Electronics. Further, you may not use any Renesas Electronics product for any application for which it is not intended without the prior written consent of Renesas Electronics. Renesas Electronics shall not be in any way liable for any damages or losses incurred by you or third parties arising from the use of any Renesas Electronics product for an application categorized as "Specific" or for which the product is not intended where you have failed to obtain the prior written consent of Renesas Electronics. The quality grade of each Renesas Electronics product is "Standard" unless otherwise expressly specified in a Renesas Electronics data sheets or data books, etc.

"Standard": Computers; office equipment; communications equipment; test and measurement equipment; audio and visual equipment; home electronic appliances; machine tools; personal electronic equipment; and industrial robots.

"High Quality": Transportation equipment (automobiles, trains, ships, etc.); traffic control systems; anti-disaster systems; anti-crime systems; safety equipment; and medical equipment not specifically designed for life support.

"Specific": Aircraft; aerospace equipment; submersible repeaters; nuclear reactor control systems; medical equipment or systems for life support (e.g. artificial life support devices or systems), surgical implantations, or healthcare intervention (e.g. excision, etc.), and any other applications or purposes that pose a direct threat to human life.

8. You should use the Renesas Electronics products described in this document within the range specified by Renesas Electronics, especially with respect to the maximum rating, operating supply voltage range, movement power voltage range, heat radiation characteristics, installation and other product characteristics. Renesas Electronics shall have no liability for malfunctions or damages arising out of the use of Renesas Electronics products beyond such specified ranges.
9. Although Renesas Electronics endeavors to improve the quality and reliability of its products, semiconductor products have specific characteristics such as the occurrence of failure at a certain rate and malfunctions under certain use conditions. Further, Renesas Electronics products are not subject to radiation resistance design. Please be sure to implement safety measures to guard them against the possibility of physical injury, and injury or damage caused by fire in the event of the failure of a Renesas Electronics product, such as safety design for hardware and software including but not limited to redundancy, fire control and malfunction prevention, appropriate treatment for aging degradation or any other appropriate measures. Because the evaluation of microcomputer software alone is very difficult, please evaluate the safety of the final products or system manufactured by you.
10. Please contact a Renesas Electronics sales office for details as to environmental matters such as the environmental compatibility of each Renesas Electronics product. Please use Renesas Electronics products in compliance with all applicable laws and regulations that regulate the inclusion or use of controlled substances, including without limitation, the EU RoHS Directive. Renesas Electronics assumes no liability for damages or losses occurring as a result of your noncompliance with applicable laws and regulations.
11. This document may not be reproduced or duplicated, in any form, in whole or in part, without prior written consent of Renesas Electronics.
12. Please contact a Renesas Electronics sales office if you have any questions regarding the information contained in this document or Renesas Electronics products, or if you have any other inquiries.

(Note 1) "Renesas Electronics" as used in this document means Renesas Electronics Corporation and also includes its majority-owned subsidiaries.

(Note 2) "Renesas Electronics product(s)" means any product developed or manufactured by or for Renesas Electronics.

The revision list can be viewed directly by clicking the title page.
The revision list summarizes the locations of revisions and additions.
Details should always be checked by referring to the relevant text.

H8S/2319 Group

Hardware Manual

Renesas 16-Bit Single-Chip
Microcomputer

H8S Family/H8S/2300 Series

Notes regarding these materials

1. This document is provided for reference purposes only so that Renesas customers may select the appropriate Renesas products for their use. Renesas neither makes warranties or representations with respect to the accuracy or completeness of the information contained in this document nor grants any license to any intellectual property rights or any other rights of Renesas or any third party with respect to the information in this document.
2. Renesas shall have no liability for damages or infringement of any intellectual property or other rights arising out of the use of any information in this document, including, but not limited to, product data, diagrams, charts, programs, algorithms, and application circuit examples.
3. You should not use the products or the technology described in this document for the purpose of military applications such as the development of weapons of mass destruction or for the purpose of any other military use. When exporting the products or technology described herein, you should follow the applicable export control laws and regulations, and procedures required by such laws and regulations.
4. All information included in this document such as product data, diagrams, charts, programs, algorithms, and application circuit examples, is current as of the date this document is issued. Such information, however, is subject to change without any prior notice. Before purchasing or using any Renesas products listed in this document, please confirm the latest product information with a Renesas sales office. Also, please pay regular and careful attention to additional and different information to be disclosed by Renesas such as that disclosed through our website. (<http://www.renesas.com>)
5. Renesas has used reasonable care in compiling the information included in this document, but Renesas assumes no liability whatsoever for any damages incurred as a result of errors or omissions in the information included in this document.
6. When using or otherwise relying on the information in this document, you should evaluate the information in light of the total system before deciding about the applicability of such information to the intended application. Renesas makes no representations, warranties or guaranties regarding the suitability of its products for any particular application and specifically disclaims any liability arising out of the application and use of the information in this document or Renesas products.
7. With the exception of products specified by Renesas as suitable for automobile applications, Renesas products are not designed, manufactured or tested for applications or otherwise in systems the failure or malfunction of which may cause a direct threat to human life or create a risk of human injury or which require especially high quality and reliability such as safety systems, or equipment or systems for transportation and traffic, healthcare, combustion control, aerospace and aeronautics, nuclear power, or undersea communication transmission. If you are considering the use of our products for such purposes, please contact a Renesas sales office beforehand. Renesas shall have no liability for damages arising out of the uses set forth above.
8. Notwithstanding the preceding paragraph, you should not use Renesas products for the purposes listed below:
 - (1) artificial life support devices or systems
 - (2) surgical implantations
 - (3) healthcare intervention (e.g., excision, administration of medication, etc.)
 - (4) any other purposes that pose a direct threat to human lifeRenesas shall have no liability for damages arising out of the uses set forth in the above and purchasers who elect to use Renesas products in any of the foregoing applications shall indemnify and hold harmless Renesas Technology Corp., its affiliated companies and their officers, directors, and employees against any and all damages arising out of such applications.
9. You should use the products described herein within the range specified by Renesas, especially with respect to the maximum rating, operating supply voltage range, movement power voltage range, heat radiation characteristics, installation and other product characteristics. Renesas shall have no liability for malfunctions or damages arising out of the use of Renesas products beyond such specified ranges.
10. Although Renesas endeavors to improve the quality and reliability of its products, IC products have specific characteristics such as the occurrence of failure at a certain rate and malfunctions under certain use conditions. Please be sure to implement safety measures to guard against the possibility of physical injury, and injury or damage caused by fire in the event of the failure of a Renesas product, such as safety design for hardware and software including but not limited to redundancy, fire control and malfunction prevention, appropriate treatment for aging degradation or any other applicable measures. Among others, since the evaluation of microcomputer software alone is very difficult, please evaluate the safety of the final products or system manufactured by you.
11. In case Renesas products listed in this document are detached from the products to which the Renesas products are attached or affixed, the risk of accident such as swallowing by infants and small children is very high. You should implement safety measures so that Renesas products may not be easily detached from your products. Renesas shall have no liability for damages arising out of such detachment.
12. This document may not be reproduced or duplicated, in any form, in whole or in part, without prior written approval from Renesas.
13. Please contact a Renesas sales office if you have any questions regarding the information contained in this document, Renesas semiconductor products, or if you have any other inquiries.

General Precautions in the Handling of MPU/MCU Products

The following usage notes are applicable to all MPU/MCU products from Renesas. For detailed usage notes on the products covered by this manual, refer to the relevant sections of the manual. If the descriptions under General Precautions in the Handling of MPU/MCU Products and in the body of the manual differ from each other, the description in the body of the manual takes precedence.

1. Handling of Unused Pins

Handle unused pins in accord with the directions given under Handling of Unused Pins in the manual.

- The input pins of CMOS products are generally in the high-impedance state. In operation with an unused pin in the open-circuit state, extra electromagnetic noise is induced in the vicinity of LSI, an associated shoot-through current flows internally, and malfunctions may occur due to the false recognition of the pin state as an input signal. Unused pins should be handled as described under Handling of Unused Pins in the manual.

2. Processing at Power-on

The state of the product is undefined at the moment when power is supplied.

- The states of internal circuits in the LSI are indeterminate and the states of register settings and pins are undefined at the moment when power is supplied.

In a finished product where the reset signal is applied to the external reset pin, the states of pins are not guaranteed from the moment when power is supplied until the reset process is completed.

In a similar way, the states of pins in a product that is reset by an on-chip power-on reset function are not guaranteed from the moment when power is supplied until the power reaches the level at which resetting has been specified.

3. Prohibition of Access to Reserved Addresses

Access to reserved addresses is prohibited.

- The reserved addresses are provided for the possible future expansion of functions. Do not access these addresses; the correct operation of LSI is not guaranteed if they are accessed.

4. Clock Signals

After applying a reset, only release the reset line after the operating clock signal has become stable. When switching the clock signal during program execution, wait until the target clock signal has stabilized.

- When the clock signal is generated with an external resonator (or from an external oscillator) during a reset, ensure that the reset line is only released after full stabilization of the clock signal. Moreover, when switching to a clock signal produced with an external resonator (or by an external oscillator) while program execution is in progress, wait until the target clock signal is stable.

5. Differences between Products

Before changing from one product to another, i.e. to one with a different type number, confirm that the change will not lead to problems.

- The characteristics of MPU/MCU in the same group but having different type numbers may differ because of the differences in internal memory capacity and layout pattern. When changing to products of different type numbers, implement a system-evaluation test for each of the products.

Preface

This LSI is a single-chip microcomputer made up of the H8S/2000 CPU with an internal 32-bit architecture as its core, and the peripheral functions required to configure a system.

This LSI is equipped with ROM, RAM, a bus controller, data transfer controller (DTC), a 16-bit timer pulse unit (TPU), a watchdog timer (WDT), a serial communication interface (SCI), a D/A converter, an A/D converter, and I/O ports as on-chip supporting modules. This LSI is suitable for use as an embedded processor for high-level control systems. Its on-chip ROM are flash memory (F-ZTAT™*) and mask ROM that provides flexibility as it can be reprogrammed in no time to cope with all situations from the early stages of mass production to full-scale mass production. This is particularly applicable to application devices with specifications that will most probably change.

Note: * F-ZTAT is a trademark of Renesas Technology Corp.

Target Users: This manual was written for users who will be using the H8S/2319 Group in the design of application systems. Members of this audience are expected to understand the fundamentals of electrical circuits, logical circuits, and microcomputers.

Objective: This manual was written to explain the hardware functions and electrical characteristics of the H8S/2319 Group to the above audience. Refer to the H8S/2600 Series, H8S/2000 Series Software Manual for a detailed description of the instruction set.

Notes on reading this manual:

- In order to understand the overall functions of the chip
Read the manual according to the contents. This manual can be roughly categorized into parts on the CPU, system control functions, peripheral functions and electrical characteristics.
- In order to understand the details of the CPU's functions
Read the H8S/2600 Series, H8S/2000 Series Software Manual.

- In order to understand the details of a register when its name is known

The addresses, bits, and initial values of the registers are summarized in appendix B, Internal I/O Registers.

Examples: Register name: The following notation is used for cases when the same or a similar function, e.g. 16-bit timer pulse unit or serial communication, is implemented on more than one channel: XXX_N (XXX is the register name and N is the channel number)

Bit order: The MSB is on the left and the LSB is on the right.

Number notation: Binary is B'xxxx, hexadecimal is H'xxxx, decimal is xxxx

Signal notation: An overbar is added to a low-active signal: $\overline{\text{xxxx}}$

Related Manuals: The latest versions of all related manuals are available from our web site. Please ensure you have the latest versions of all documents you require. (<http://www.renesas.com/>)

H8S/2319 Group manuals:

Document Title	Document No.
H8S/2319 Group Hardware Manual	This manual
H8S/2600 Series, H8S/2000 Series Software Manual	REJ09B0139

User's manuals for development tools:

Document Title	Document No.
H8S, H8/300 Series C/C++ Compiler, Assembler, Optimized Linkage Editor User's Manual	REJ10B0058
H8S, H8/300 Series Simulator/Debugger (for Windows) User's Manual	ADE-702-037
High-performance Embedded Workshop (for Windows 95/98 and Windows NT 4.0) User's Manual	ADE-702-201

Application Notes:

Document Title	Document No.
H8S Series Technical Q&A Application Note	REJ05B0397

Main Revisions for This Edition

Item	Page	Revision (See Manual for Details)
1.3.1 Pin Arrangement Figure 1.6 HD64F2319CLP, HD6432317SLP, HD6432316SLP Pin Arrangement (TLP-113V: Top View)	13	Figure 1.6 amended (Before) TLP-113V (Top View) → (After) (Top View)
2.6.3 Table of Instructions Classified by Function Table 2.3 Instructions Classified by Function	45	Table 2.3 amended MOVFPPE, MOVTPPE (Before) Cannot be used in the H8S/2357 Series. → (After) Cannot be used in the H8S/2319 Group.
6.3.5 Chip Select Signals	156	Description amended ... the data direction register (DDR) ,CS167 Enable(CS167E), CS25 Enable, CSS17, CSS36, PF1CS5S, PF0CS4S for the port corresponding to the particular CSn pin. ... the corresponding control registers bits should be set when outputting signals CS1 to CS7. ... the corresponding control registers bits should be set when outputting signals CS0 to CS7. ...
8.2.2 Register Configuration	223, 224	Port 1 Data Direction Register (P1DDR) Port 1 Data Register (P1DR) Port 1 Register (PORT1) Description amended (Before) ... retains its prior state after in software standby mode. → (After) ... retains its prior state in software standby mode.
8.3.2 Register Configuration	236, 237	Port 2 Data Direction Register (P2DDR) Port 2 Data Register (P2DR) Port 2 Register (PORT2) Description amended (Before) ... retains its prior state after in software standby mode. → (After) ... retains its prior state in software standby mode.

Item	Page	Revision (See Manual for Details)
8.4.2 Register Configuration	247, 248	Port 3 Data Direction Register (P3DDR) Port 3 Data Register (P3DR) Port 3 Register (PORT3) Port 3 Open Drain Control Register (P3ODR) Description amended (Before) ... retains its prior state after in software standby mode. → (After) ... retains its prior state in software standby mode.
8.6.2 Register Configuration	254 to 256	Port A Data Direction Register (PADDDR) Port A Data Register (PADR) Port A Register (PORTA) Port A Open Drain Control Register (PAODR) Description amended (Before) ... retains its prior state after in software standby mode. → (After) ... retains its prior state in software standby mode.
8.11.2 Register Configuration	284, 285	Port F Data Direction Register (PFDDR) Port F Data Register (PFDR) Port F Register (PORTF) Description amended (Before) ... retains its prior state after in software standby mode. → (After) ... retains its prior state in software standby mode.
8.12.2 Register Configuration	294, 295	Port G Data Direction Register (PGDDR) Port G Data Register (PGDR) Port G Register (PORTG) Description amended (Before) ... retains its prior state after in software standby mode. → (After) ... retains its prior state in software standby mode.

12.2.8 Bit Rate Register (BRR) 452 Table 12.3 amended

Table 12.3 BRR Settings for Various Bit Rates (Asynchronous Mode)

Bit Rate (bits/s)	$\phi = 25 \text{ MHz}$		
	n	N	Error (%)
110	3	110	-0.02
150	3	80	0.47
300	2	162	-0.15
600	2	80	0.47
1200	1	162	-0.15
2400	1	80	0.47
4800	0	162	-0.15
9600	0	80	0.47
19200	0	40	-0.76
31250	0	24	0.00
38400	0	19	1.73

14.4.3 Input Sampling and A/D Conversion Time 545 Figure 14.5 amended

Figure 14.5 A/D Conversion Timing

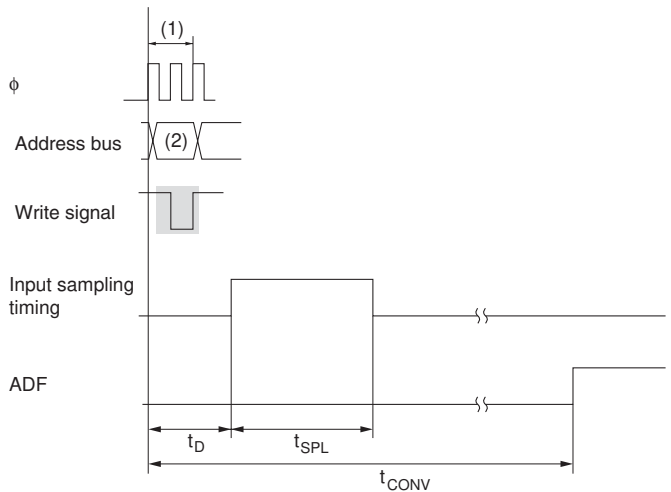

17.4.1 Features 571 Description amended

- Reprogramming capability

The flash memory can be reprogrammed a minimum of 100 times.

Item	Page	Revision (See Manual for Details)																									
17.8.3 Error Protection	604	Description amended (Before) • When a bus master other than the CPU (the DMAC or DTC) has control ... → (After) • When a bus master other than the CPU (the DTC) has control ...																									
17.11.2 Socket Adapters and Memory Map	609	Description added In programmer mode, ... figure 17.21. This enables the chip to fit a 40-pin socket. Figure 17.20 shows ...																									
17.13.1 Features	629	Description amended • Reprogramming capability The flash memory can be reprogrammed a minimum of 100 times.																									
17.17.3 Error Protection	664	Description amended (Before) • When a bus master other than the CPU (the DMAC or DTC) has control ... → (After) • When a bus master other than the CPU (the DTC) has control ...																									
17.20.2 Socket Adapters and Memory Map	670	Description added In programmer mode, ... figure 17.51. This enables the chip to fit a 40-pin socket. Figure 17.50 shows ...																									
17.22.1 Features	686	Description amended • Protection modes There are three protection modes: software protection by the register setting, hardware protection by reset/hardware standby, and error protection. The protection ...																									
17.22.4 Mode Comparison Table 17.46 Comparison of Programming Modes	690	Table 17.46 amended <table border="1"> <thead> <tr> <th></th> <th>Boot mode</th> <th>User program mode</th> <th>User boot mode</th> <th>PROM mode</th> </tr> </thead> <tbody> <tr> <td>Programming/Erasing Environment</td> <td>On-board programming</td> <td>On-board programming</td> <td>On-board programming</td> <td>On-board programming</td> </tr> <tr> <td>Programming/Erasing Enable MAT</td> <td>User MAT User boot MAT</td> <td>User MAT</td> <td>User MAT</td> <td>User MAT User boot MAT</td> </tr> <tr> <td>Program/Erase Control</td> <td>Command method</td> <td>Programming/Erasing Interface</td> <td>Programming/Erasing Interface</td> <td>Command method</td> </tr> <tr> <td>All Erasure</td> <td>○ (Automatic)</td> <td>○</td> <td>○</td> <td>○ (Automatic)</td> </tr> </tbody> </table>		Boot mode	User program mode	User boot mode	PROM mode	Programming/Erasing Environment	On-board programming	On-board programming	On-board programming	On-board programming	Programming/Erasing Enable MAT	User MAT User boot MAT	User MAT	User MAT	User MAT User boot MAT	Program/Erase Control	Command method	Programming/Erasing Interface	Programming/Erasing Interface	Command method	All Erasure	○ (Automatic)	○	○	○ (Automatic)
	Boot mode	User program mode	User boot mode	PROM mode																							
Programming/Erasing Environment	On-board programming	On-board programming	On-board programming	On-board programming																							
Programming/Erasing Enable MAT	User MAT User boot MAT	User MAT	User MAT	User MAT User boot MAT																							
Program/Erase Control	Command method	Programming/Erasing Interface	Programming/Erasing Interface	Command method																							
All Erasure	○ (Automatic)	○	○	○ (Automatic)																							
17.23.2 Programming/Erasing Interface Parameter	704	Description amended ... the CPU except for ER0 and ER1 are stored. The return value of ... the registers except for ER0 and ER1, the stack area must be ...																									

Item	Page	Revision (See Manual for Details)										
17.24.2 User Program Mode	729	Programming Procedure in User Program Mode: Description amended (g) Initialization <ul style="list-style-type: none"> The general registers other than ER0 and ER1 are saved in the initialization program. 										
	730	(l) Programming <ul style="list-style-type: none"> The general registers other than ER0 and ER1 are saved in the programming program. 										
17.25 Protection	738	Description amended There are three kinds of flash memory program/erase protection: hardware, software protection, and error protection.										
17.29.1 Serial Communication Interface Specification for Boot Mode	754	Status Description amended (2) Inquiry/Selection State ... required for erasure to the on-chip RAM and erases ... (3) Programming/erasing state ... the programming/erasing programs to the on-chip RAM by commands ...										
	759	Inquiry and Selection States Description amended (2) Device Selection <ul style="list-style-type: none"> Size (1 byte): Amount of device-code data This is fixed to 4 										
	760	(3) Clock Mode Inquiry (Before) <table border="1" style="margin-left: 40px;"> <tr> <td>Response</td> <td>H'31</td> <td>Size</td> <td>A number of modes</td> <td>Mode</td> <td>SUM</td> </tr> </table> (After) <table border="1" style="margin-left: 120px;"> <tr> <td>Response</td> <td>H'31</td> <td>Size</td> <td>Mode</td> <td>SUM</td> </tr> </table> <ul style="list-style-type: none"> Size (1 byte): Amount of data that represents the modes Mode (1 byte): Values of the supported ... 	Response	H'31	Size	A number of modes	Mode	SUM	Response	H'31	Size	Mode
Response	H'31	Size	A number of modes	Mode	SUM							
Response	H'31	Size	Mode	SUM								

Item	Page	Revision (See Manual for Details)
17.29.1 Serial Communication Interface Specification for Boot Mode	773	Programming/Erasing State (4) 128-Byte Programming Description amended <ul style="list-style-type: none"> ERROR: (1 byte) Error code <ul style="list-style-type: none"> H'11: Checksum error H'2A: Address error

Item	Storable/Executable Area			Selected MAT		
	On-Chip RAM	User Boot MAT	External Space (Expanded Mode)	User MAT	User Boot MAT	Embedded Program Storage Area
Switching MATs by FMATS	○	×	×	■	○	

17.29.3 Procedure Program and storable Area for Programming Data
Table 17.73 (3)
Usable Area for Programming in User Boot Mode

Operating Mode	Transition Condition	Clearing Condition	Oscillator
High speed mode	Control register	Control register	Functions
Medium-speed mode	Control register	Control register	Functions
Sleep mode	Instruction	Interrupt	Functions
Module stop mode	Control register	Control register	Functions
Software standby mode	Instruction	External interrupt	Halted
Hardware standby mode	Pin	Pin	Halted

19.1 Overview 802 Table 19.1 amended
Table 19.1
Operating Modes

20.2.5 D/A Conversion Characteristics Table 20.18 D/A Conversion Characteristics	848	"—Preliminary—" deleted from table 20.18
---	-----	--

Item	Page	Revision (See Manual for Details)																																										
20.2.6 Flash Memory Characteristics Table 20.19 Flash Memory Characteristics	848	"—Preliminary—" deleted from table 20.19																																										
20.1 Electrical Characteristics of Mask ROM Version (H8S/2319, H8S/2318, H8S/2317S, H8S/2316S, H8S/2315, H8S/2314) and ROMless Version (H8S/2312S)	817	Section 20.1 title amended																																										
20.2.6 Flash Memory Characteristics Table 20.19 Flash Memory Characteristics	849	Table 20.19 amended																																										
		<table border="1"> <thead> <tr> <th>Item</th> <th>Symbol</th> <th>Min</th> <th>Typ</th> <th>Max</th> <th>Unit</th> <th>Test Conditions</th> </tr> </thead> <tbody> <tr> <td>Programming time^{*1 *2 *4}</td> <td>t_p</td> <td>—</td> <td>10</td> <td>200</td> <td>ms/128 bytes</td> <td></td> </tr> <tr> <td>Erase time^{*1 *3 *6}</td> <td>t_E</td> <td>—</td> <td>50</td> <td>1000</td> <td>ms/block</td> <td></td> </tr> <tr> <td>Reprogramming count</td> <td>N_{WEC}</td> <td>100^{*7}</td> <td>10000^{*8}</td> <td>—</td> <td>Times</td> <td></td> </tr> <tr> <td>Data retention time^{*9}</td> <td>t_{DRP}</td> <td>10</td> <td>—</td> <td>—</td> <td>Years</td> <td></td> </tr> <tr> <td>Programming Wait time after SWE bit setting^{*1}</td> <td>x</td> <td>1</td> <td>—</td> <td>—</td> <td>μs</td> <td></td> </tr> </tbody> </table>	Item	Symbol	Min	Typ	Max	Unit	Test Conditions	Programming time ^{*1 *2 *4}	t _p	—	10	200	ms/128 bytes		Erase time ^{*1 *3 *6}	t _E	—	50	1000	ms/block		Reprogramming count	N _{WEC}	100 ^{*7}	10000 ^{*8}	—	Times		Data retention time ^{*9}	t _{DRP}	10	—	—	Years		Programming Wait time after SWE bit setting ^{*1}	x	1	—	—	μs	
Item	Symbol	Min	Typ	Max	Unit	Test Conditions																																						
Programming time ^{*1 *2 *4}	t _p	—	10	200	ms/128 bytes																																							
Erase time ^{*1 *3 *6}	t _E	—	50	1000	ms/block																																							
Reprogramming count	N _{WEC}	100 ^{*7}	10000 ^{*8}	—	Times																																							
Data retention time ^{*9}	t _{DRP}	10	—	—	Years																																							
Programming Wait time after SWE bit setting ^{*1}	x	1	—	—	μs																																							
	850	Notes 7 to 9 added Notes: 7. Minimum number of times for which all characteristics are guaranteed after rewriting (Guarantee range is 1 to minimum value). 8. Reference value for 25°C (as a guideline, rewriting should normally function up to this value). 9. Data retention characteristic when rewriting is performed within the specification range, including the minimum value.																																										
20.3.2 DC Characteristics Table 20.21 DC Characteristics	853	Table 20.21 amended																																										
		<table border="1"> <thead> <tr> <th>Item</th> <th>Symbol</th> <th>Min</th> <th>Typ</th> <th>MaxU</th> <th>nit</th> <th>Test Conditions</th> </tr> </thead> <tbody> <tr> <td>VCC start voltage^{*5}</td> <td>VCC_{START}</td> <td>—</td> <td>—</td> <td>0.4</td> <td>V</td> <td></td> </tr> <tr> <td>VCC rising edge^{*5}</td> <td>SVCC</td> <td>—</td> <td>—</td> <td>10</td> <td>ms/V</td> <td></td> </tr> </tbody> </table>	Item	Symbol	Min	Typ	MaxU	nit	Test Conditions	VCC start voltage ^{*5}	VCC _{START}	—	—	0.4	V		VCC rising edge ^{*5}	SVCC	—	—	10	ms/V																						
Item	Symbol	Min	Typ	MaxU	nit	Test Conditions																																						
VCC start voltage ^{*5}	VCC _{START}	—	—	0.4	V																																							
VCC rising edge ^{*5}	SVCC	—	—	10	ms/V																																							
		Note 5 added Note: 5. Applies on condition that the $\overline{\text{RES}}$ pin is low level at power on.																																										

Item	Page	Revision (See Manual for Details)																					
20.3.6 Flash Memory 860 Characteristics		Table 20.29 amended																					
Table 20.29 Flash Memory Characteristics		<table border="1"> <thead> <tr> <th>Item</th> <th>Symbol</th> <th>Min</th> <th>Typ</th> <th>Max</th> <th>Unit</th> <th>Test Conditions</th> </tr> </thead> <tbody> <tr> <td>Number of overwrites</td> <td>NWEC</td> <td>100^{*3}</td> <td>10000^{*5}</td> <td>—</td> <td>Times</td> <td></td> </tr> <tr> <td>Data retention time^{*4}</td> <td>t_{DRP}</td> <td>10</td> <td>—</td> <td>—</td> <td>Years</td> <td></td> </tr> </tbody> </table>	Item	Symbol	Min	Typ	Max	Unit	Test Conditions	Number of overwrites	NWEC	100 ^{*3}	10000 ^{*5}	—	Times		Data retention time ^{*4}	t _{DRP}	10	—	—	Years	
Item	Symbol	Min	Typ	Max	Unit	Test Conditions																	
Number of overwrites	NWEC	100 ^{*3}	10000 ^{*5}	—	Times																		
Data retention time ^{*4}	t _{DRP}	10	—	—	Years																		
		Note 5 added																					
		Note: 5. Reference value for 25°C (as a guideline, rewriting should normally function up to this value).																					
Appendix E Products Lineup	1103	Table E.1 amended																					
Table E.1 H8S/2319 Group Products Lineup		HD64F2319E ^{*1} H8S/2317(S) ^{**2}																					
	1104	Notes amended																					
		Notes: 1. The on-chip debug function can be used with the E10A emulator (E10A compatible version). 2. H8S/2317S in mask ROM version.																					
F. Package Dimensions		Figure F.4 replaced																					
Figure F.4 TLP-113V Package Dimensions																							

All trademarks and registered trademarks are the property of their respective owners.

Contents

Section 1	Overview	1
1.1	Overview	1
1.2	Block Diagram	8
1.3	Pin Description	9
1.3.1	Pin Arrangement	9
1.3.2	Pin Functions in Each Operating Mode	14
1.3.3	Pin Functions	18
Section 2	CPU	27
2.1	Overview	27
2.1.1	Features	27
2.1.2	Differences between H8S/2600 CPU and H8S/2000 CPU	28
2.1.3	Differences from H8/300 CPU	29
2.1.4	Differences from H8/300H CPU	29
2.2	CPU Operating Modes	30
2.3	Address Space	33
2.4	Register Configuration	34
2.4.1	Overview	34
2.4.2	General Registers	35
2.4.3	Control Registers	36
2.4.4	Initial Register Values	38
2.5	Data Formats	38
2.5.1	General Register Data Formats	39
2.5.2	Memory Data Formats	41
2.6	Instruction Set	42
2.6.1	Overview	42
2.6.2	Instructions and Addressing Modes	43
2.6.3	Table of Instructions Classified by Function	44
2.6.4	Basic Instruction Formats	54
2.7	Addressing Modes and Effective Address Calculation	55
2.7.1	Addressing Mode	55
2.7.2	Effective Address Calculation	58
2.8	Processing States	62
2.8.1	Overview	62
2.8.2	Reset State	63
2.8.3	Exception-Handling State	64
2.8.4	Program Execution State	66

2.8.5	Bus-Released State.....	66
2.8.6	Power-Down State	66
2.9	Basic Timing.....	67
2.9.1	Overview.....	67
2.9.2	On-Chip Memory (ROM, RAM).....	67
2.9.3	On-Chip Supporting Module Access Timing.....	69
2.9.4	External Address Space Access Timing	70
2.10	Usage Note.....	70
2.10.1	TAS Instruction.....	70
Section 3 MCU Operating Modes		71
3.1	Overview.....	71
3.1.1	Operating Mode Selection (H8S/2318 F-ZTAT, H8S/2317 F-ZTAT, H8S/2315 F-ZTAT, and H8S/2314 F-ZTAT).....	71
3.1.2	Operating Mode Selection (Mask ROM, ROMless, H8S/2319 F-ZTAT, and H8S/2319C F-ZTAT).....	72
3.1.3	Register Configuration.....	74
3.2	Register Descriptions	74
3.2.1	Mode Control Register (MDCR)	74
3.2.2	System Control Register (SYSCR).....	75
3.2.3	System Control Register 2 (SYSCR2) (F-ZTAT Versions Only).....	76
3.3	Operating Mode Descriptions	77
3.3.1	Mode 1 (H8S/2319C F-ZTAT Only).....	77
3.3.2	Mode 2 (H8S/2319 F-ZTAT and H8S/2319C F-ZTAT Only).....	77
3.3.3	Mode 3 (H8S/2319 F-ZTAT and H8S/2319C F-ZTAT Only).....	78
3.3.4	Mode 4 (Expanded Mode with On-Chip ROM Disabled)	78
3.3.5	Mode 5 (Expanded Mode with On-Chip ROM Disabled)	78
3.3.6	Mode 6 (Expanded Mode with On-Chip ROM Enabled)	79
3.3.7	Mode 7 (Single-Chip Mode).....	79
3.3.8	Modes 8 and 9.....	79
3.3.9	Mode 10 (H8S/2318 F-ZTAT, H8S/2317 F-ZTAT, H8S/2315 F-ZTAT, and H8S/2314 F-ZTAT Only)	79
3.3.10	Mode 11 (H8S/2318 F-ZTAT, H8S/2317 F-ZTAT, H8S/2315 F-ZTAT, and H8S/2314 F-ZTAT Only)	79
3.3.11	Modes 12 and 13.....	80
3.3.12	Mode 14 (H8S/2318 F-ZTAT, H8S/2317 F-ZTAT, H8S/2315 F-ZTAT, and H8S/2314 F-ZTAT Only)	80
3.3.13	Mode 15 (H8S/2318 F-ZTAT, H8S/2317 F-ZTAT, H8S/2315 F-ZTAT, and H8S/2314 F-ZTAT Only)	80
3.4	Pin Functions in Each Operating Mode	80

3.5	Memory Map in Each Operating Mode	81
Section 4 Exception Handling		99
4.1	Overview.....	99
4.1.1	Exception Handling Types and Priority	99
4.1.2	Exception Handling Operation.....	100
4.1.3	Exception Vector Table	100
4.2	Reset.....	102
4.2.1	Overview.....	102
4.2.2	Reset Sequence	102
4.2.3	Interrupts after Reset.....	103
4.2.4	State of On-Chip Supporting Modules after Reset Release	103
4.3	Traces.....	104
4.4	Interrupts	105
4.5	Trap Instruction.....	106
4.6	Stack Status after Exception Handling.....	106
4.7	Notes on Use of the Stack	107
Section 5 Interrupt Controller		109
5.1	Overview.....	109
5.1.1	Features	109
5.1.2	Block Diagram.....	110
5.1.3	Pin Configuration.....	111
5.1.4	Register Configuration.....	111
5.2	Register Descriptions	112
5.2.1	System Control Register (SYSCR).....	112
5.2.2	Interrupt Priority Registers A to K (IPRA to IPRK).....	113
5.2.3	IRQ Enable Register (IER)	114
5.2.4	IRQ Sense Control Registers H and L (ISCRH, ISCRL).....	115
5.2.5	IRQ Status Register (ISR).....	116
5.3	Interrupt Sources	117
5.3.1	External Interrupts	117
5.3.2	Internal Interrupts.....	118
5.3.3	Interrupt Exception Vector Table	118
5.4	Interrupt Operation.....	124
5.4.1	Interrupt Control Modes and Interrupt Operation	124
5.4.2	Interrupt Control Mode 0	127
5.4.3	Interrupt Control Mode 2	129
5.4.4	Interrupt Exception Handling Sequence	131
5.4.5	Interrupt Response Times	133

5.5	Usage Notes	134
5.5.1	Contention between Interrupt Generation and Disabling	134
5.5.2	Instructions that Disable Interrupts	135
5.5.3	Times when Interrupts are Disabled	135
5.5.4	Interrupts during Execution of EEPMOV Instruction.....	135
5.6	DTC Activation by Interrupt.....	136
5.6.1	Overview.....	136
5.6.2	Block Diagram.....	136
5.6.3	Operation	137
Section 6 Bus Controller.....		139
6.1	Overview.....	139
6.1.1	Features.....	139
6.1.2	Block Diagram.....	140
6.1.3	Pin Configuration.....	141
6.1.4	Register Configuration.....	142
6.2	Register Descriptions	143
6.2.1	Bus Width Control Register (ABWCR).....	143
6.2.2	Access State Control Register (ASTCR)	144
6.2.3	Wait Control Registers H and L (WCRH, WCRL).....	145
6.2.4	Bus Control Register H (BCRH)	148
6.2.5	Bus Control Register L (BCRL)	150
6.3	Overview of Bus Control	152
6.3.1	Area Partitioning.....	152
6.3.2	Bus Specifications.....	153
6.3.3	Memory Interfaces	154
6.3.4	Advanced Mode.....	155
6.3.5	Chip Select Signals	156
6.4	Basic Bus Interface	157
6.4.1	Overview.....	157
6.4.2	Data Size and Data Alignment.....	157
6.4.3	Valid Strokes.....	159
6.4.4	Basic Timing.....	160
6.4.5	Wait Control	168
6.5	Burst ROM Interface.....	170
6.5.1	Overview.....	170
6.5.2	Basic Timing.....	170
6.5.3	Wait Control	172
6.6	Idle Cycle.....	173
6.6.1	Operation	173

6.6.2	Pin States in Idle Cycle	176
6.7	Bus Release	177
6.7.1	Overview	177
6.7.2	Operation	177
6.7.3	Pin States in External Bus Released State	178
6.7.4	Transition Timing	179
6.7.5	Usage Note	180
6.8	Bus Arbitration	180
6.8.1	Overview	180
6.8.2	Operation	180
6.8.3	Bus Transfer Timing	181
6.8.4	External Bus Release Usage Note	181
6.9	Resets and the Bus Controller	181
Section 7 Data Transfer Controller		183
7.1	Overview	183
7.1.1	Features	183
7.1.2	Block Diagram	184
7.1.3	Register Configuration	185
7.2	Register Descriptions	186
7.2.1	DTC Mode Register A (MRA)	186
7.2.2	DTC Mode Register B (MRB)	187
7.2.3	DTC Source Address Register (SAR)	189
7.2.4	DTC Destination Address Register (DAR)	189
7.2.5	DTC Transfer Count Register A (CRA)	189
7.2.6	DTC Transfer Count Register B (CRB)	190
7.2.7	DTC Enable Registers (DTCER)	190
7.2.8	DTC Vector Register (DTVECR)	191
7.2.9	Module Stop Control Register (MSTPCR)	192
7.3	Operation	193
7.3.1	Overview	193
7.3.2	Activation Sources	197
7.3.3	DTC Vector Table	198
7.3.4	Location of Register Information in Address Space	201
7.3.5	Normal Mode	202
7.3.6	Repeat Mode	203
7.3.7	Block Transfer Mode	204
7.3.8	Chain Transfer	206
7.3.9	Operation Timing	207
7.3.10	Number of DTC Execution States	208

7.3.11	Procedures for Using DTC.....	210
7.3.12	Examples of Use of the DTC	211
7.4	Interrupts	215
7.5	Usage Notes	215
Section 8 I/O Ports.....		217
8.1	Overview.....	217
8.2	Port 1.....	222
8.2.1	Overview.....	222
8.2.2	Register Configuration.....	223
8.2.3	Pin Functions	227
8.3	Port 2.....	235
8.3.1	Overview.....	235
8.3.2	Register Configuration.....	235
8.3.3	Pin Functions	238
8.4	Port 3.....	246
8.4.1	Overview.....	246
8.4.2	Register Configuration.....	246
8.4.3	Pin Functions	249
8.5	Port 4.....	251
8.5.1	Overview.....	251
8.5.2	Register Configuration.....	252
8.5.3	Pin Functions	252
8.6	Port A.....	253
8.6.1	Overview.....	253
8.6.2	Register Configuration.....	254
8.6.3	Pin Functions	257
8.6.4	MOS Input Pull-Up Function.....	258
8.7	Port B.....	259
8.7.1	Overview.....	259
8.7.2	Register Configuration.....	260
8.7.3	Pin Functions	262
8.7.4	MOS Input Pull-Up Function.....	264
8.8	Port C.....	265
8.8.1	Overview.....	265
8.8.2	Register Configuration.....	266
8.8.3	Pin Functions	268
8.8.4	MOS Input Pull-Up Function.....	270
8.9	Port D.....	271
8.9.1	Overview.....	271

8.9.2	Register Configuration.....	272
8.9.3	Pin Functions	275
8.9.4	MOS Input Pull-Up Function.....	276
8.10	Port E.....	277
8.10.1	Overview.....	277
8.10.2	Register Configuration.....	278
8.10.3	Pin Functions	280
8.10.4	MOS Input Pull-Up Function.....	282
8.11	Port F.....	283
8.11.1	Overview.....	283
8.11.2	Register Configuration.....	284
8.11.3	Pin Functions	290
8.12	Port G.....	293
8.12.1	Overview.....	293
8.12.2	Register Configuration.....	294
8.12.3	Pin Functions	298
Section 9 16-Bit Timer Pulse Unit (TPU).....		301
9.1	Overview.....	301
9.1.1	Features.....	301
9.1.2	Block Diagram.....	305
9.1.3	Pin Configuration.....	306
9.1.4	Register Configuration.....	308
9.2	Register Descriptions	310
9.2.1	Timer Control Registers (TCR)	310
9.2.2	Timer Mode Registers (TMDR)	315
9.2.3	Timer I/O Control Registers (TIOR).....	317
9.2.4	Timer Interrupt Enable Registers (TIER)	330
9.2.5	Timer Status Registers (TSR)	333
9.2.6	Timer Counters (TCNT)	336
9.2.7	Timer General Registers (TGR).....	337
9.2.8	Timer Start Register (TSTR).....	337
9.2.9	Timer Synchro Register (TSYR)	338
9.2.10	Module Stop Control Register (MSTPCR).....	339
9.3	Interface to Bus Master	340
9.3.1	16-Bit Registers	340
9.3.2	8-Bit Registers	340
9.4	Operation.....	342
9.4.1	Overview.....	342
9.4.2	Basic Functions.....	343

9.4.3	Synchronous Operation.....	349
9.4.4	Buffer Operation.....	351
9.4.5	Cascaded Operation.....	355
9.4.6	PWM Modes.....	357
9.4.7	Phase Counting Mode.....	363
9.5	Interrupts.....	369
9.5.1	Interrupt Sources and Priorities.....	369
9.5.2	DTC Activation.....	371
9.5.3	A/D Converter Activation.....	371
9.6	Operation Timing.....	372
9.6.1	Input/Output Timing.....	372
9.6.2	Interrupt Signal Timing.....	376
9.7	Usage Notes.....	380
Section 10 8-Bit Timers.....		391
10.1	Overview.....	391
10.1.1	Features.....	391
10.1.2	Block Diagram.....	392
10.1.3	Pin Configuration.....	393
10.1.4	Register Configuration.....	393
10.2	Register Descriptions.....	394
10.2.1	Timer Counters 0 and 1 (TCNT0, TCNT1).....	394
10.2.2	Time Constant Registers A0 and A1 (TCORA0, TCORA1).....	394
10.2.3	Time Constant Registers B0 and B1 (TCORB0, TCORB1).....	395
10.2.4	Time Control Registers 0 and 1 (TCR0, TCR1).....	395
10.2.5	Timer Control/Status Registers 0 and 1 (TCSR0, TCSR1).....	397
10.2.6	Module Stop Control Register (MSTPCR).....	400
10.3	Operation.....	401
10.3.1	TCNT Incrementation Timing.....	401
10.3.2	Compare Match Timing.....	402
10.3.3	Timing of TCNT External Reset.....	404
10.3.4	Timing of Overflow Flag (OVF) Setting.....	404
10.3.5	Operation with Cascaded Connection.....	405
10.4	Interrupts.....	406
10.4.1	Interrupt Sources and DTC Activation.....	406
10.4.2	A/D Converter Activation.....	406
10.5	Sample Application.....	407
10.6	Usage Notes.....	408
10.6.1	Contention between TCNT Write and Clear.....	408
10.6.2	Contention between TCNT Write and Increment.....	409

10.6.3	Contention between TCOR Write and Compare Match	410
10.6.4	Contention between Compare Matches A and B	411
10.6.5	Switching of Internal Clocks and TCNT Operation.....	411
10.6.6	Interrupts and Module Stop Mode	413
Section 11 Watchdog Timer		415
11.1	Overview.....	415
11.1.1	Features	415
11.1.2	Block Diagram.....	416
11.1.3	Pin Configuration.....	417
11.1.4	Register Configuration.....	417
11.2	Register Descriptions	418
11.2.1	Timer Counter (TCNT).....	418
11.2.2	Timer Control/Status Register (TCSR).....	419
11.2.3	Reset Control/Status Register (RSTCSR).....	421
11.2.4	Notes on Register Access.....	422
11.3	Operation.....	423
11.3.1	Operation in Watchdog Timer Mode	423
11.3.2	Operation in Interval Timer Mode	425
11.3.3	Timing of Overflow Flag (OVF) Setting	426
11.3.4	Timing of Watchdog Timer Overflow Flag (WOVF) Setting.....	427
11.4	Interrupts	428
11.5	Usage Notes	428
11.5.1	Contention between Timer Counter (TCNT) Write and Increment	428
11.5.2	Changing Value of CKS2 to CKS0.....	429
11.5.3	Switching between Watchdog Timer Mode and Interval Timer Mode.....	429
11.5.4	System Reset by $\overline{\text{WDTOVF}}$ Signal.....	429
11.5.5	Internal Reset in Watchdog Timer Mode.....	430
Section 12 Serial Communication Interface (SCI)		431
12.1	Overview.....	431
12.1.1	Features	431
12.1.2	Block Diagram.....	433
12.1.3	Pin Configuration.....	434
12.1.4	Register Configuration.....	435
12.2	Register Descriptions	436
12.2.1	Receive Shift Register (RSR)	436
12.2.2	Receive Data Register (RDR).....	436
12.2.3	Transmit Shift Register (TSR).....	437
12.2.4	Transmit Data Register (TDR).....	437

12.2.5	Serial Mode Register (SMR).....	438
12.2.6	Serial Control Register (SCR).....	441
12.2.7	Serial Status Register (SSR)	445
12.2.8	Bit Rate Register (BRR)	449
12.2.9	Smart Card Mode Register (SCMR).....	457
12.2.10	Module Stop Control Register (MSTPCR).....	459
12.3	Operation.....	460
12.3.1	Overview.....	460
12.3.2	Operation in Asynchronous Mode	462
12.3.3	Multiprocessor Communication Function.....	473
12.3.4	Operation in Synchronous Mode	481
12.4	SCI Interrupts.....	490
12.5	Usage Notes	491
Section 13 Smart Card Interface.....		499
13.1	Overview.....	499
13.1.1	Features	499
13.1.2	Block Diagram	500
13.1.3	Pin Configuration.....	501
13.1.4	Register Configuration.....	502
13.2	Register Descriptions	503
13.2.1	Smart Card Mode Register (SCMR).....	503
13.2.2	Serial Status Register (SSR)	504
13.2.3	Serial Mode Register (SMR).....	506
13.2.4	Serial Control Register (SCR).....	508
13.3	Operation.....	509
13.3.1	Overview.....	509
13.3.2	Pin Connections	510
13.3.3	Data Format	511
13.3.4	Register Settings	513
13.3.5	Clock.....	515
13.3.6	Data Transfer Operations	517
13.3.7	Operation in GSM Mode	525
13.3.8	Operation in Block Transfer Mode.....	526
13.4	Usage Notes	526
Section 14 A/D Converter (8 Analog Input Channel Version)		531
14.1	Overview.....	531
14.1.1	Features	531
14.1.2	Block Diagram.....	532

14.1.3	Pin Configuration.....	533
14.1.4	Register Configuration.....	534
14.2	Register Descriptions	535
14.2.1	A/D Data Registers A to D (ADDRA to ADDR D)	535
14.2.2	A/D Control/Status Register (ADCSR)	536
14.2.3	A/D Control Register (ADCR)	538
14.2.4	Module Stop Control Register (MSTPCR).....	539
14.3	Interface to Bus Master.....	540
14.4	Operation.....	541
14.4.1	Single Mode (SCAN = 0)	541
14.4.2	Scan Mode (SCAN = 1).....	543
14.4.3	Input Sampling and A/D Conversion Time.....	545
14.4.4	External Trigger Input Timing	546
14.5	Interrupts	547
14.6	Usage Notes	548
Section 15 D/A Converter.....		553
15.1	Overview.....	553
15.1.1	Features	553
15.1.2	Block Diagram.....	554
15.1.3	Pin Configuration.....	555
15.1.4	Register Configuration.....	555
15.2	Register Descriptions	556
15.2.1	D/A Data Registers 0, 1 (DADR0, DADR1)	556
15.2.2	D/A Control Registers 01 (DACR01).....	556
15.2.3	Module Stop Control Register (MSTPCR).....	558
15.3	Operation.....	559
Section 16 RAM		561
16.1	Overview.....	561
16.1.1	Block Diagram.....	561
16.1.2	Register Configuration.....	562
16.2	Register Descriptions	562
16.2.1	System Control Register (SYSCR).....	562
16.3	Operation.....	563
16.4	Usage Note.....	563
Section 17 ROM		565
17.1	Overview.....	565
17.1.1	Block Diagram.....	565

17.1.2	Register Configuration.....	566
17.2	Register Descriptions.....	566
17.2.1	Mode Control Register (MDCR).....	566
17.2.2	Bus Control Register L (BCRL).....	567
17.3	Operation.....	567
17.4	Overview of Flash Memory (H8S/2318 F-ZTAT, H8S/2317 F-ZTAT, H8S/2315 F-ZTAT, H8S/2314 F-ZTAT).....	571
17.4.1	Features.....	571
17.4.2	Overview.....	572
17.4.3	Flash Memory Operating Modes.....	573
17.4.4	On-Board Programming Modes.....	574
17.4.5	Flash Memory Emulation in RAM.....	576
17.4.6	Differences between Boot Mode and User Program Mode.....	577
17.4.7	Block Configuration.....	578
17.4.8	Pin Configuration.....	579
17.4.9	Register Configuration.....	580
17.5	Register Descriptions.....	581
17.5.1	Flash Memory Control Register 1 (FLMCR1).....	581
17.5.2	Flash Memory Control Register 2 (FLMCR2).....	584
17.5.3	Erase Block Register 1 (EBR1).....	585
17.5.4	Erase Block Register 2 (EBR2).....	585
17.5.5	System Control Register 2 (SYSCR2).....	586
17.5.6	RAM Emulation Register (RAMER).....	587
17.6	On-Board Programming Modes.....	589
17.6.1	Boot Mode.....	590
17.6.2	User Program Mode.....	595
17.7	Programming/Erasing Flash Memory.....	597
17.7.1	Program Mode.....	597
17.7.2	Program-Verify Mode.....	598
17.7.3	Erase Mode.....	600
17.7.4	Erase-Verify Mode.....	600
17.8	Flash Memory Protection.....	602
17.8.1	Hardware Protection.....	602
17.8.2	Software Protection.....	602
17.8.3	Error Protection.....	603
17.9	Flash Memory Emulation in RAM.....	605
17.9.1	Emulation in RAM.....	605
17.9.2	RAM Overlap.....	606
17.10	Interrupt Handling when Programming/Erasing Flash Memory.....	607
17.11	Flash Memory Programmer Mode.....	608

17.11.1	Programmer Mode Setting	608
17.11.2	Socket Adapters and Memory Map.....	609
17.11.3	Programmer Mode Operation	611
17.11.4	Memory Read Mode	613
17.11.5	Auto-Program Mode	616
17.11.6	Auto-Erase Mode	618
17.11.7	Status Read Mode	620
17.11.8	Status Polling	621
17.11.9	Programmer Mode Transition Time.....	622
17.11.10	Notes on Memory Programming.....	623
17.12	Flash Memory Programming and Erasing Precautions	623
17.13	Overview of Flash Memory (H8S/2319 F-ZTAT).....	629
17.13.1	Features	629
17.13.2	Overview.....	630
17.13.3	Flash Memory Operating Modes	631
17.13.4	On-Board Programming Modes.....	632
17.13.5	Flash Memory Emulation in RAM	634
17.13.6	Differences between Boot Mode and User Program Mode	635
17.13.7	Block Configuration.....	636
17.13.8	Pin Configuration.....	637
17.13.9	Register Configuration.....	638
17.14	Register Descriptions	639
17.14.1	Flash Memory Control Register 1 (FLMCR1).....	639
17.14.2	Flash Memory Control Register 2 (FLMCR2).....	642
17.14.3	Erase Block Register 1 (EBR1)	645
17.14.4	Erase Block Register 2 (EBR2)	646
17.14.5	System Control Register 2 (SYSCR2)	647
17.14.6	RAM Emulation Register (RAMER).....	647
17.15	On-Board Programming Modes	649
17.15.1	Boot Mode	650
17.15.2	User Program Mode.....	654
17.16	Programming/Erasing Flash Memory	656
17.16.1	Program Mode (n = 1 for addresses H'000000 to H'03FFFF, and n = 2 for addresses H'040000 to H'07FFFF)	656
17.16.2	Program-Verify Mode (n = 1 for addresses H'000000 to H'03FFFF, and n = 2 for addresses H'040000 to H'07FFFF)	657
17.16.3	Erase Mode (n = 1 for addresses H'000000 to H'03FFFF, and n = 2 for addresses H'040000 to H'07FFFF)	659
17.16.4	Erase-Verify Mode (n = 1 for addresses H'000000 to H'03FFFF, and n = 2 for addresses H'040000 to H'07FFFF)	660

17.17	Flash Memory Protection	662
17.17.1	Hardware Protection	662
17.17.2	Software Protection.....	663
17.17.3	Error Protection.....	664
17.18	Flash Memory Emulation in RAM	666
17.18.1	Emulation in RAM.....	666
17.18.2	RAM Overlap	667
17.19	Interrupt Handling when Programming/Erasing Flash Memory	668
17.20	Flash Memory Programmer Mode	669
17.20.1	Programmer Mode Setting.....	669
17.20.2	Socket Adapters and Memory Map.....	670
17.20.3	Programmer Mode Operation	672
17.20.4	Memory Read Mode	673
17.20.5	Auto-Program Mode	677
17.20.6	Auto-Erase Mode	679
17.20.7	Status Read Mode	680
17.20.8	Status Polling	681
17.20.9	Programmer Mode Transition Time.....	682
17.20.10	Notes on Memory Programming.....	682
17.21	Flash Memory Programming and Erasing Precautions	684
17.22	Overview of Flash Memory (H8S/2319C 0.18μm F-ZTAT).....	686
17.22.1	Features.....	686
17.22.2	Overview.....	688
17.22.3	Operating Mode of Flash Memory.....	689
17.22.4	Mode Comparison.....	690
17.22.5	Flash MAT Configuration.....	691
17.22.6	Block Division	692
17.22.7	Programming/Erasing Interface	693
17.22.8	Pin Configuration.....	695
17.22.9	Register Configuration.....	695
17.23	Register Description of Flash Memory	697
17.23.1	Programming/Erasing Interface Register.....	697
17.23.2	Programming/Erasing Interface Parameter	704
17.23.3	System Control Register 2 (SYSCR2).....	717
17.23.4	RAM Emulation Register (RAMER).....	718
17.24	On-Board Programming Mode	720
17.24.1	Boot Mode	720
17.24.2	User Program Mode.....	724
17.24.3	User Boot Mode.....	734
17.25	Protection.....	738

17.25.1	Hardware Protection	738
17.25.2	Software Protection.....	739
17.25.3	Error Protection.....	739
17.26	Flash Memory Emulation in RAM	741
17.27	Switching between User MAT and User Boot MAT	744
17.27.1	Usage Notes	745
17.28	PROM Mode	746
17.28.1	Pin Arrangement of the Socket Adapter	747
17.28.2	PROM Mode Operation.....	749
17.28.3	Memory-Read Mode.....	750
17.28.4	Auto-Program Mode	751
17.28.5	Auto-Erase Mode	751
17.28.6	Status-Read Mode	752
17.28.7	Status Polling	752
17.28.8	Time Taken in Transition to PROM Mode	753
17.28.9	Notes on Using PROM Mode	753
17.29	Further Information.....	754
17.29.1	Serial Communication Interface Specification for Boot Mode.....	754
17.29.2	AC Characteristics and Timing in PROM Mode	781
17.29.3	Procedure Program and Storable Area for Programming Data.....	787
Section 18 Clock Pulse Generator		793
18.1	Overview.....	793
18.1.1	Block Diagram.....	793
18.1.2	Register Configuration.....	794
18.2	Register Descriptions	794
18.2.1	System Clock Control Register (SCKCR)	794
18.3	Oscillator.....	796
18.3.1	Connecting a Crystal Resonator.....	796
18.3.2	External Clock Input	798
18.4	Duty Adjustment Circuit.....	800
18.5	Medium-Speed Clock Divider	800
18.6	Bus Master Clock Selection Circuit	800
Section 19 Power-Down Modes		801
19.1	Overview.....	801
19.1.1	Register Configuration.....	802
19.2	Register Descriptions	803
19.2.1	Standby Control Register (SBYCR)	803
19.2.2	System Clock Control Register (SCKCR)	805

19.2.3	Module Stop Control Register (MSTPCR)	807
19.3	Medium-Speed Mode.....	807
19.4	Sleep Mode	808
19.5	Module Stop Mode.....	809
19.5.1	Module Stop Mode	809
19.5.2	Usage Notes	810
19.6	Software Standby Mode.....	811
19.6.1	Software Standby Mode.....	811
19.6.2	Clearing Software Standby Mode.....	811
19.6.3	Setting Oscillation Stabilization Time after Clearing Software Standby Mode... 812	
19.6.4	Software Standby Mode Application Example.....	812
19.6.5	Usage Notes	813
19.7	Hardware Standby Mode	814
19.7.1	Hardware Standby Mode	814
19.7.2	Hardware Standby Mode Timing.....	814
19.8	ϕ Clock Output Disabling Function	815
Section 20 Electrical Characteristics		817
20.1	Electrical Characteristics of Mask ROM Version (H8S/2319, H8S/2318, H8S/2317S, H8S/2316S, H8S/2315, H8S/2314) and ROMless Version (H8S/2312S)	817
20.1.1	Absolute Maximum Ratings	817
20.1.2	DC Characteristics	818
20.1.3	AC Characteristics	820
20.1.4	A/D Conversion Characteristics.....	838
20.1.5	D/A Conversion Characteristics.....	839
20.2	Electrical Characteristics of F-ZTAT Versions (H8S/2319 F-ZTAT, H8S/2319E F-ZTAT, H8S/2318 F-ZTAT, H8S/2317 F-ZTAT, H8S/2315 F-ZTAT, H8S/2314 F-ZTAT)	840
20.2.1	Absolute Maximum Ratings	840
20.2.2	DC Characteristics	841
20.2.3	AC Characteristics	844
20.2.4	A/D Conversion Characteristics.....	848
20.2.5	D/A Conversion Characteristics.....	848
20.2.6	Flash Memory Characteristics	849
20.3	Electrical Characteristics of F-ZTAT Version (H8S/2319C F-ZTAT).....	851
20.3.1	Absolute Maximum Ratings	851
20.3.2	DC Characteristics	852
20.3.3	AC Characteristics	855
20.3.4	A/D Conversion Characteristics.....	859
20.3.5	D/A Conversion Characteristics.....	859

20.3.6	Flash Memory Characteristics	860
20.3.7	Usage Note (Internal voltage step down for the H8S/2319C F-ZTAT).....	861
20.4	Usage Note.....	861
Appendix A Instruction Set		863
A.1	Instruction List	863
A.2	Instruction Codes	887
A.3	Operation Code Map.....	902
A.4	Number of States Required for Instruction Execution	906
A.5	Bus States during Instruction Execution	920
A.6	Condition Code Modification	934
Appendix B Internal I/O Registers		940
B.1	List of Registers (Address Order)	940
B.2	List of Registers (By Module).....	949
B.3	Functions.....	958
Appendix C I/O Port Block Diagrams		1069
C.1	Port 1.....	1069
C.2	Port 2.....	1073
C.3	Port 3.....	1074
C.4	Port 4.....	1077
C.5	Port A.....	1078
C.6	Port B	1079
C.7	Port C.....	1080
C.8	Port D.....	1081
C.9	Port E	1082
C.10	Port F.....	1083
C.11	Port G.....	1091
Appendix D Pin States		1096
D.1	Port States in Each Mode	1096
Appendix E Product Lineup.....		1103
Appendix F Package Dimensions		1105

Section 1 Overview

1.1 Overview

The H8S/2319 Group is a series of microcomputer (MCU: microcomputer unit), built around the H8S/2000 CPU, employing Renesas's proprietary architecture, and equipped with supporting functions on-chip.

The H8S/2000 CPU has an internal 32-bit architecture, is provided with sixteen 16-bit general registers and a concise, optimized instruction set designed for high-speed operation, and can address a 16-Mbyte linear address space. The instruction set is upward-compatible with H8/300 and H8/300H CPU instructions at the object-code level, facilitating migration from the H8/300, H8/300L, or H8/300H Series.

On-chip supporting functions required for system configuration include data transfer controller (DTC) bus masters, ROM and RAM, a 16-bit timer-pulse unit (TPU), 8-bit timer, watchdog timer (WDT), serial communication interface (SCI), A/D converter, D/A converter, and I/O ports.

Single-power-supply flash memory (F-ZTAT™*) and mask ROM versions are available, providing a quick and flexible response to conditions from ramp-up through full-scale volume production, even for applications with frequently changing specifications. ROM is connected to the CPU via a 16-bit data bus, enabling both byte and word data to be accessed in one state. Instruction fetching is thus speeded up, and processing speed increased.

The features of the H8S/2319 Group are shown in table 1.1.

Note: *F-ZTAT is a trademark of Renesas Technology Corp.

Table 1.1 Overview

Item	Specification
CPU	<ul style="list-style-type: none">• General-register machine<ul style="list-style-type: none">— Sixteen 16-bit general registers (also usable as sixteen 8-bit registers or eight 32-bit registers)• High-speed operation suitable for realtime control<ul style="list-style-type: none">— Maximum clock rate: 25 MHz— High-speed arithmetic operations<ul style="list-style-type: none">8/16/32-bit register-register add/subtract: 40 ns (at 25-MHz operation)16 × 16-bit register-register multiply: 800 ns (at 25-MHz operation)32 ÷ 16-bit register-register divide: 800 ns (at 25-MHz operation)• Instruction set suitable for high-speed operation<ul style="list-style-type: none">— Sixty-five basic instructions— 8/16/32-bit move/arithmetic and logic instructions— Unsigned/signed multiply and divide instructions— Powerful bit-manipulation instructions• CPU operating mode<ul style="list-style-type: none">— Advanced mode: 16-Mbyte address space
Bus controller	<ul style="list-style-type: none">• Address space divided into 8 areas, with bus specifications settable independently for each area• Chip select output possible for each area• Choice of 8-bit or 16-bit access space for each area• 2-state or 3-state access space can be designated for each area• Number of program wait states can be set for each area• Burst ROM directly connectable• External bus release function
Data transfer controller (DTC)	<ul style="list-style-type: none">• Can be activated by internal interrupt or software• Multiple transfers or multiple types of transfer possible for one activation source• Transfer possible in repeat mode, block transfer mode, etc.• Request can be sent to CPU for interrupt that activated DTC
16-bit timer-pulse unit (TPU)	<ul style="list-style-type: none">• 6-channel 16-bit timer• Pulse I/O processing capability for up to 16 pins• Automatic 2-phase encoder count capability

Item	Specification																											
8-bit timer, 2 channels	<ul style="list-style-type: none"> • 8-bit up-counter (external event count capability) • Two time constant registers • Two-channel connection possible 																											
Watchdog timer	<ul style="list-style-type: none"> • Watchdog timer or interval timer selectable 																											
Serial communication interface (SCI), 2 channels	<ul style="list-style-type: none"> • Asynchronous mode or synchronous mode selectable • Multiprocessor communication function • Smart card interface function 																											
A/D converter	<ul style="list-style-type: none"> • Resolution: 10 bits • Input: 8 channels • High-speed conversion: 6.7 μs minimum conversion time (at 20-MHz operation) • Single or scan mode selectable • Sample-and-hold circuit • A/D conversion can be activated by external trigger or timer trigger 																											
D/A converter	<ul style="list-style-type: none"> • Resolution: 8 bits • Output: 2 channels 																											
I/O ports	<ul style="list-style-type: none"> • 70 input/output pins, 9 input pins 																											
Memory	<ul style="list-style-type: none"> • Flash memory, mask ROM • High-speed static RAM <table border="1"> <thead> <tr> <th>Product Name</th> <th>ROM</th> <th>RAM</th> </tr> </thead> <tbody> <tr> <td>H8S/2319C</td> <td>512 kbytes</td> <td>16 kbytes</td> </tr> <tr> <td>H8S/2319</td> <td>512 kbytes</td> <td>8 kbytes</td> </tr> <tr> <td>H8S/2318</td> <td>256 kbytes</td> <td>8 kbytes</td> </tr> <tr> <td>H8S/2317(S)*</td> <td>128 kbytes</td> <td>8 kbytes</td> </tr> <tr> <td>H8S/2316S</td> <td>64 kbytes</td> <td>8 kbytes</td> </tr> <tr> <td>H8S/2315</td> <td>384 kbytes</td> <td>8 kbytes</td> </tr> <tr> <td>H8S/2314</td> <td>384 kbytes</td> <td>4 kbytes</td> </tr> <tr> <td>H8S/2312S</td> <td>—</td> <td>8 kbytes</td> </tr> </tbody> </table> <p>Note: * H8S/2317S in mask ROM version.</p>	Product Name	ROM	RAM	H8S/2319C	512 kbytes	16 kbytes	H8S/2319	512 kbytes	8 kbytes	H8S/2318	256 kbytes	8 kbytes	H8S/2317(S)*	128 kbytes	8 kbytes	H8S/2316S	64 kbytes	8 kbytes	H8S/2315	384 kbytes	8 kbytes	H8S/2314	384 kbytes	4 kbytes	H8S/2312S	—	8 kbytes
Product Name	ROM	RAM																										
H8S/2319C	512 kbytes	16 kbytes																										
H8S/2319	512 kbytes	8 kbytes																										
H8S/2318	256 kbytes	8 kbytes																										
H8S/2317(S)*	128 kbytes	8 kbytes																										
H8S/2316S	64 kbytes	8 kbytes																										
H8S/2315	384 kbytes	8 kbytes																										
H8S/2314	384 kbytes	4 kbytes																										
H8S/2312S	—	8 kbytes																										
Interrupt controller	<ul style="list-style-type: none"> • 9 external interrupt pins (NMI, $\overline{\text{IRQ0}}$ to $\overline{\text{IRQ7}}$) • 43 internal interrupt sources • Eight priority levels settable 																											

Item	Specification
------	---------------

- | | |
|------------------|--|
| Power-down state | <ul style="list-style-type: none"> • Medium-speed mode • Sleep mode • Module stop mode • Software standby mode • Hardware standby mode • Variable clock division ratio |
|------------------|--|

- | | |
|-----------------|--|
| Operating modes | <ul style="list-style-type: none"> • Eight MCU operating modes (H8S/2318 F-ZTAT, H8S/2317 F-ZTAT, H8S/2315 F-ZTAT, H8S/2314 F-ZTAT) |
|-----------------|--|

Mode	CPU Operating Mode	Description	On-Chip ROM	External Data Bus	
				Initial Value	Maximum Value
1	—	—	—	—	—
2	—	—	—	—	—
3	—	—	—	—	—
4	Advanced	On-chip ROM disabled expansion mode	Disabled	16 bits	16 bits
5				8 bits	16 bits
6	Advanced	On-chip ROM enabled expansion mode	Enabled	8 bits	16 bits
7				—	—
8	—	—	—	—	—
9	—	—	—	—	—
10	Advanced	Boot mode	Enabled	8 bits	16 bits
11				—	—
12	—	—	—	—	—
13	—	—	—	—	—
14	Advanced	User program mode	Enabled	8 bits	16 bits
15				—	—

Item	Specification					
Operating modes	<ul style="list-style-type: none"> Four MCU operating modes (ROMless, mask ROM versions, H8S/2319 F-ZTAT, and H8S/2319C F-ZTAT) 					
	Mode CPU Operating Mode	Description	On-Chip ROM	External Data Bus		
				Initial Value	Maximum Value	
	1 ^{*1}	—	—	—	—	—
	2 ^{*2}	—	—	—	—	—
	3 ^{*2}	—	—	—	—	—
	4 ^{*3}	Advanced	On-chip ROM disabled expansion mode	Disabled	16 bits	16 bits
	5 ^{*3}	—	On-chip ROM disabled expansion mode	Disabled	8 bits	16 bits
	6	—	On-chip ROM enabled expansion mode	Enabled	8 bits	16 bits
	7	—	Single-chip mode	Enabled	—	—
	Notes: 1. User boot mode in the H8S/2319C F-ZTAT. For user boot mode in the H8S/2319C F-ZTAT, see table 17.52. 2. Boot mode in the H8S/2319 F-ZTAT and H8S/2319C F-ZTAT. For boot mode in the H8S/2319 F-ZTAT, see table 17.30. Also see table 17.30, for information on user program mode. For boot mode in the H8S/2319C F-ZTAT, see table 17.52. Also see table 17.52, for information on user program mode. 3. The ROMless version can use only modes 4 and 5.					
Clock pulse generator	<ul style="list-style-type: none"> Built-in duty correction circuit 					

Item		Specification	
Product lineup		Condition A	Condition B
Operating power supply voltage		2.7 to 3.6 V	3.0 to 3.6 V
Operating frequency		2 to 20 MHz	2 to 25 MHz
Model	HD64F2319	—	○
	HD64F2319E*	—	○
	HD64F2319C	—	○
	HD6432319	○	○
	HD64F2318	—	○
	HD6432318	○	○
	HD64F2317	—	○
	HD6432317S	○	○
	HD6432316S	○	○
	HD64F2315	—	○
	HD6432315	○	○
	HD64F2314	—	○
	HD6432314	○	○
	HD6412312S	○	○

○: Products in the current lineup

Note: *The on-chip debug function can be used with the E10A emulator (E10A compatible version). However, some function modules and pin functions are unavailable when the on-chip debug function is in use. Refer to figure 1.4 and figure 1.5. (The SCI channel 1 is unavailable when the on-chip debug function is in use. Also, since the WDT continues to operate during break status, a reset is generated when an overflow occurs if a setting is made to reset the chip internally.)

Item	Specification
Other features	<ul style="list-style-type: none">• Differences between H8S/2319 F-ZTAT and H8S/2319C F-ZTAT<ul style="list-style-type: none">— On-chip RAM<ul style="list-style-type: none">H8S/2319 F-ZTAT: 8 kbytes (H'FFDC00 to H'FFFBFF)H8S/2319C F-ZTAT: 16 kbytes (H'FFBC00 to H'FFFBFF)— On-chip flash memory<p>The H8S/2319 F-ZTAT and H8S/2319C F-ZTAT both have 512 kbytes of on-chip flash memory. However, the method for controlling the flash memory is different for the two LSIs. When the on-chip flash memory is enabled, the registers (parameters) used to control it are different. For details, see the section about the H8S/2319 F-ZTAT and H8S/2319C F-ZTAT in section 17, ROM.</p>— Address map<p>The address maps of the H8S/2319 F-ZTAT and H8S/2319C F-ZTAT differ in places. For details, see section 3.5, Memory Map in Each Operating Mode.</p>

1.2 Block Diagram

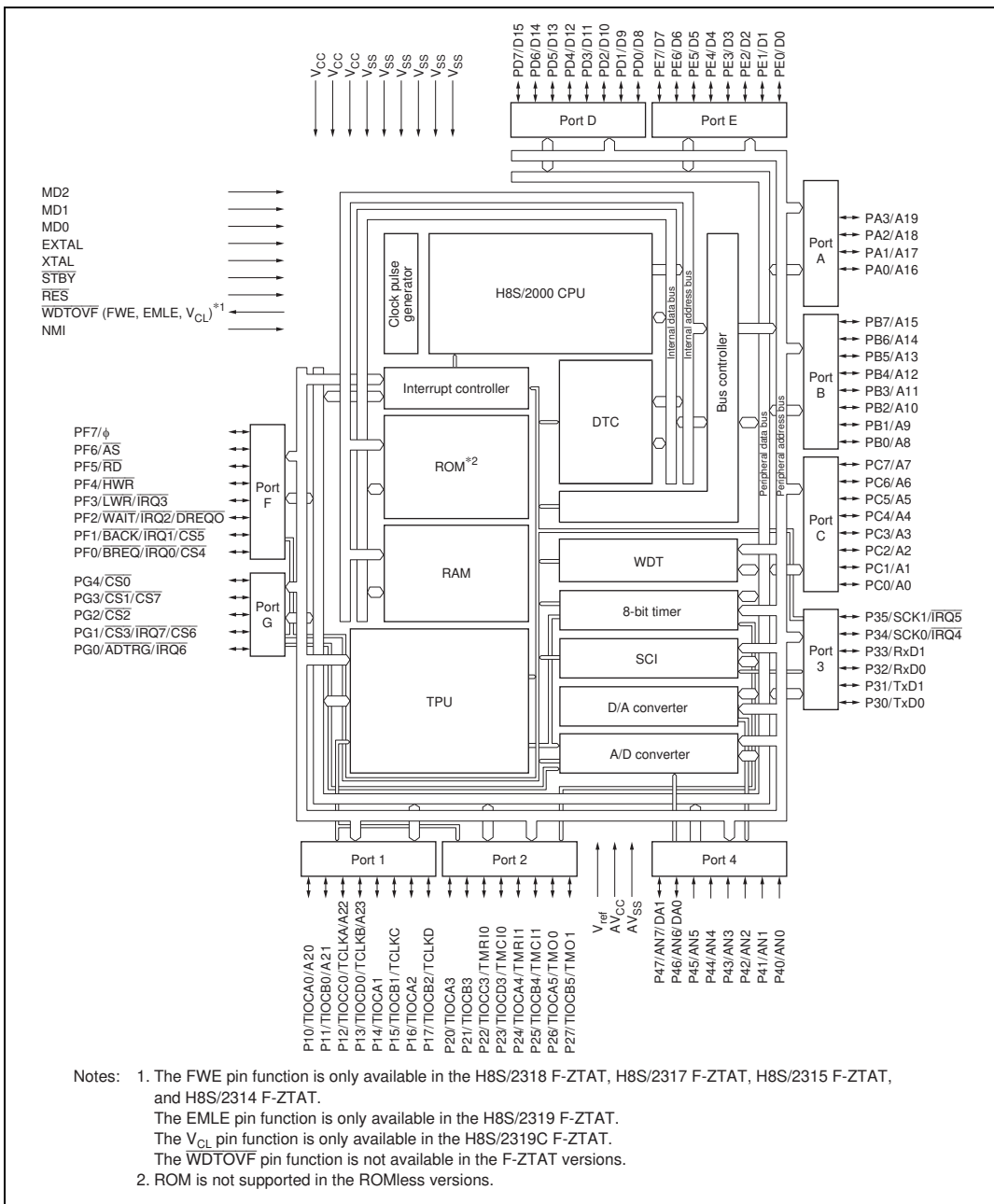

Figure 1.1 Block Diagram

1.3 Pin Description

1.3.1 Pin Arrangement

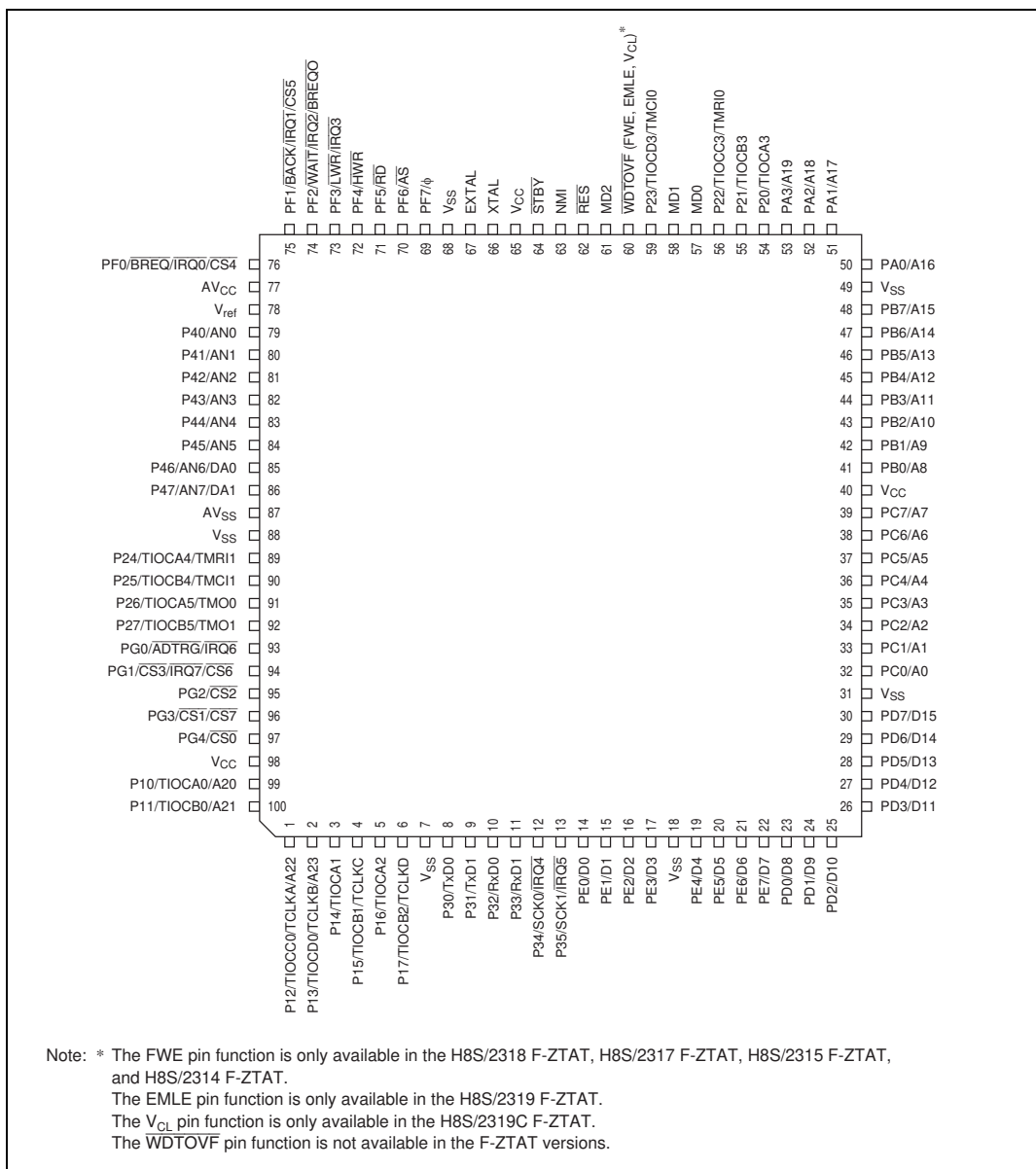
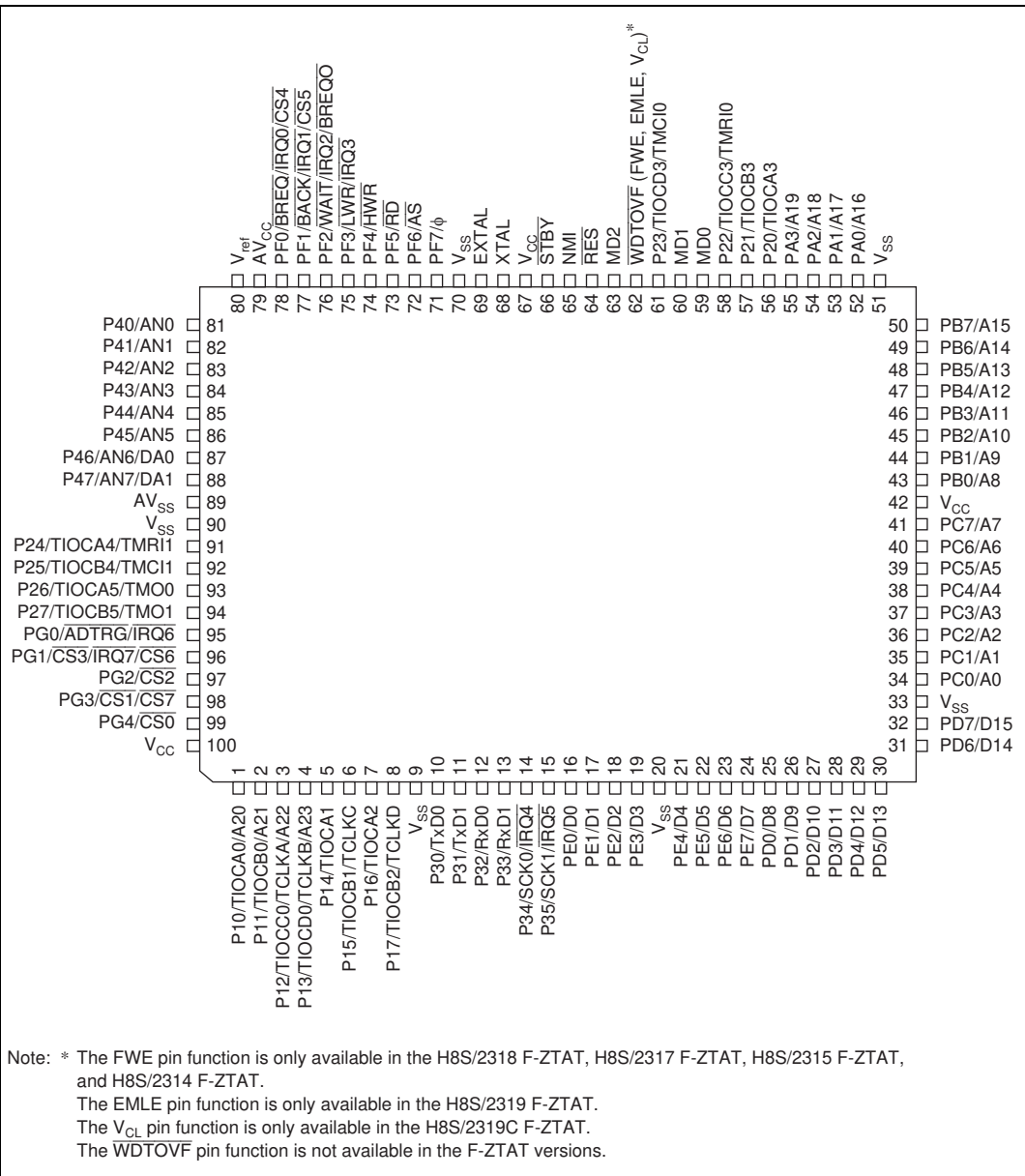

Figure 1.2 Pin Arrangement (TFP-100B, TFP-100G: Top View)



Note: * The FWE pin function is only available in the H8S/2318 F-ZTAT, H8S/2317 F-ZTAT, H8S/2315 F-ZTAT, and H8S/2314 F-ZTAT.
 The EMLE pin function is only available in the H8S/2319 F-ZTAT.
 The V_{CL} pin function is only available in the H8S/2319C F-ZTAT.
 The WDTOVF pin function is not available in the F-ZTAT versions.

Figure 1.3 Pin Arrangement (FP-100A: Top View)

E10A compatible version

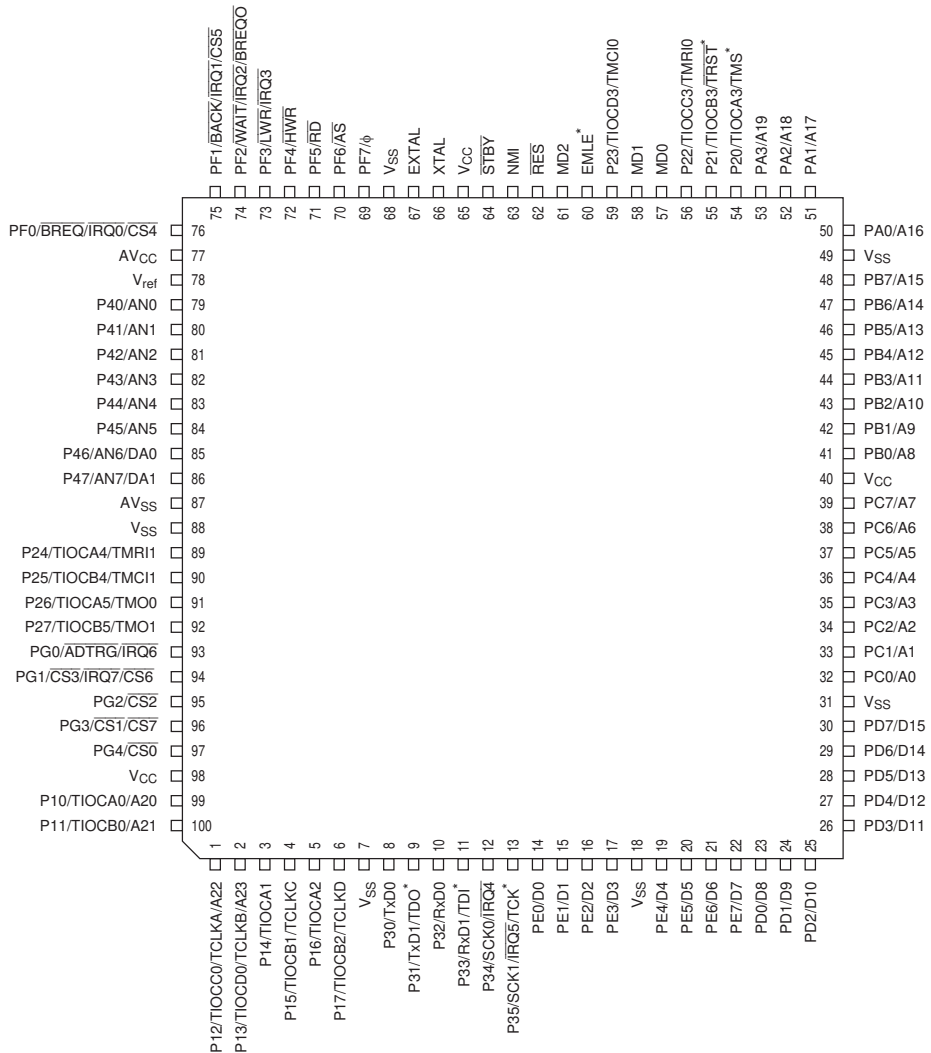

Note: * If an E10A emulator is used, the TDO, TDI, TDK, TMS, and TRST pins are used exclusively for the H-UDI and the functions and function modules associated with these pins are not available. (The SCI channel 1 is unavailable when the on-chip debug function is in use. Also, since the WDT continues to operate during break status, a reset is generated when an overflow occurs if a setting is made to reset the chip internally.)
 Refer to the H8S, H8SX Family E10A-USB Emulator User's Manual for E10A emulator connection examples.
 Refer to the H8S/2319 F-ZTAT section for HD64F2319E.

Figure 1.4 HD64F2319E Pin Arrangement (TFP-100B: Top View)

E10A compatible version

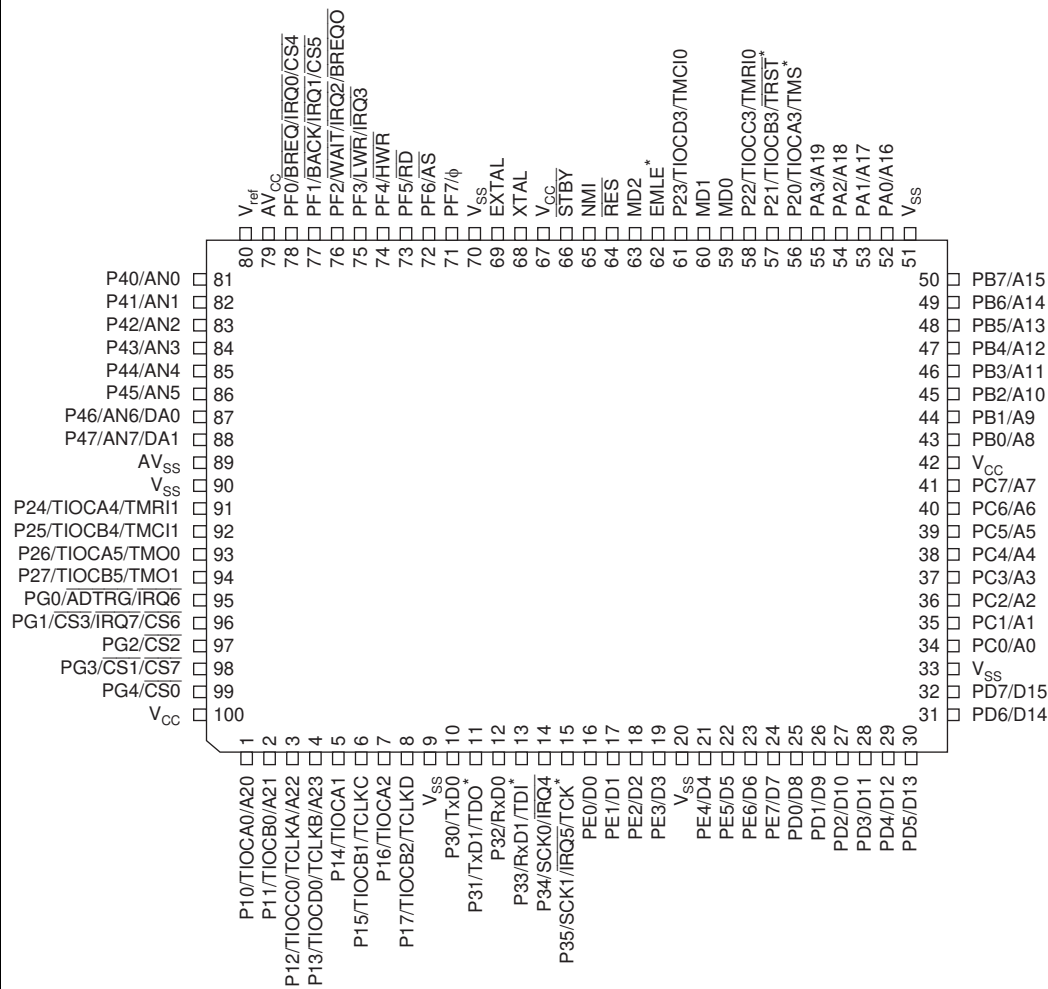

Note: * If an E10A emulator is used, the TDO, TDI, TDK, TMS, and TRST pins are used exclusively for the H-UDI and the functions and function modules associated with these pins are not available. (The SCI channel 1 is unavailable when the on-chip debug function is in use. Also, since the WDT continues to operate during break status, a reset is generated when an overflow occurs if a setting is made to reset the chip internally.)
 Refer to the H8S, H8SX Family E10A-USB Emulator User's Manual for E10A emulator connection examples.
 Refer to the H8S/2319 F-ZTAT section for HD64F2319E.

Figure 1.5 HD64F2319E Pin Arrangement (FP-100A: Top View)

	1	2	3	4	5	6	7	8	9	10	11
A	NC	P11	PG3	PG2	P26	VSS	P45	P41	VREF	PF0	AVCC
B	P12	P10	VCC	PG4	NC	P27	AVSS	P44	P42	PF2	PF1
C	P13	P16	NC	P14	PG1	PG0	P47	P43	NC	PF3	PF4
D	P15	VSS	P17	NC	P25	P24	P46	PF5	P40	NC	PF7
E	P30	P33	P32	P31	NC			STBY	VSS	PF6	VCC
F	P34	PE2	PE3	P35	(Top View)			NMI	EXTAL	XTAL	RES
G	PE1	PE5	VSS	PE0				VCL (NC)*1	NC (WDTOVF) *2	MD2	P23
H	PE4	NC	PD6	PE6	PC2	PC6	PC7	NC	MD0	MD1	P21
J	NC	PD0	PE7	VSS	PC3	PB1	PB2	P20	PB6	P22	PA3
K	PD2	PD1	VSS	PC0	PC4	PB0	PB4	PB5	PB7	VSS	PA1
L	PD4	PD3	PD5	PD7	PC1	PC5	VCC	PB3	NC	PA0	PA2

Notes: 1. NC on H8S/2316S and H8S/2317S.
2. $\overline{\text{WDTOVF}}$ on H8S/2316S and H8S/2317S.

Figure 1.6 HD64F2319CLP, HD6432317SLP, HD6432316SLP Pin Arrangement (TLP-113V: Top View)

1.3.2 Pin Functions in Each Operating Mode

Table 1.2 shows the pin functions in each of the operating modes.

Table 1.2 Pin Functions in Each Operating Mode

Pin No.			Pin Name				Flash Memory Programmer Mode
TFP-100B, TFP-100G	FP-100A	TLP-113V	Mode 4	Mode 5	Mode 6 ^{*1}	Mode 7 ^{*1}	
1	3	B1	P12/TIOCC0/ TCLKA/A22	P12/TIOCC0/ TCLKA/A22	P12/TIOCC0/ TCLKA/A22	P12/TIOCC0/ TCLKA	NC
2	4	C1	P13/TIOCD0/ TCLKB/A23	P13/TIOCD0/ TCLKB/A23	P13/TIOCD0/ TCLKB/A23	P13/TIOCD0/ TCLKB	NC
3	5	C4	P14/TIOCA1	P14/TIOCA1	P14/TIOCA1	P14/TIOCA1	NC
4	6	D1	P15/TIOCB1/ TCLKC	P15/TIOCB1/ TCLKC	P15/TIOCB1/ TCLKC	P15/TIOCB1/ TCLKC	NC
5	7	C2	P16/TIOCA2	P16/TIOCA2	P16/TIOCA2	P16/TIOCA2	NC
6	8	D3	P17/TIOCB2/ TCLKD	P17/TIOCB2/ TCLKD	P17/TIOCB2/ TCLKD	P17/TIOCB2/ TCLKD	NC
7	9	D2	V _{SS}	V _{SS}	V _{SS}	V _{SS}	V _{SS}
8	10	E1	P30/TxD0	P30/TxD0	P30/TxD0	P30/TxD0	NC
9	11	E4	P31/TxD1	P31/TxD1	P31/TxD1	P31/TxD1	NC
10	12	E3	P32/RxD0	P32/RxD0	P32/RxD0	P32/RxD0	NC
11	13	E2	P33/RxD1	P33/RxD1	P33/RxD1	P33/RxD1	NC
12	14	F1	P34/SCK0/ $\overline{\text{IRQ4}}$	P34/SCK0/ $\overline{\text{IRQ4}}$	P34/SCK0/ $\overline{\text{IRQ4}}$	P34/SCK0/ $\overline{\text{IRQ4}}$	NC
13	15	F4	P35/SCK1/ $\overline{\text{IRQ5}}$	P35/SCK1/ $\overline{\text{IRQ5}}$	P35/SCK1/ $\overline{\text{IRQ5}}$	P35/SCK1/ $\overline{\text{IRQ5}}$	NC
14	16	G4	PE0/D0	PE0/D0	PE0/D0	PE0	NC
15	17	G1	PE1/D1	PE1/D1	PE1/D1	PE1	NC
16	18	F2	PE2/D2	PE2/D2	PE2/D2	PE2	NC
17	19	F3	PE3/D3	PE3/D3	PE3/D3	PE3	NC
18	20	G3	V _{SS}	V _{SS}	V _{SS}	V _{SS}	V _{SS}
19	21	H1	PE4/D4	PE4/D4	PE4/D4	PE4	NC
20	22	G2	PE5/D5	PE5/D5	PE5/D5	PE5	NC
21	23	H4	PE6/D6	PE6/D6	PE6/D6	PE6	NC
22	24	J3	PE7/D7	PE7/D7	PE7/D7	PE7	NC
23	25	J2	D8	D8	D8	PD0	I/O0
24	26	K2	D9	D9	D9	PD1	I/O1
25	27	K1	D10	D10	D10	PD2	I/O2
26	28	L2	D11	D11	D11	PD3	I/O3

Pin No.			Pin Name				Flash Memory Programmer Mode
TFP-100B, TFP-100G	FP-100A	TLP-113V	Mode 4	Mode 5	Mode 6 ³¹	Mode 7 ³¹	
27	29	L1	D12	D12	D12	PD4	I/O4
28	30	L3	D13	D13	D13	PD5	I/O5
29	31	H3	D14	D14	D14	PD6	I/O6
30	32	L4	D15	D15	D15	PD7	I/O7
31	33	J4	V _{SS}	V _{SS}	V _{SS}	V _{SS}	V _{SS}
32	34	K4	A0	A0	PC0/A0	PC0	A0
33	35	L5	A1	A1	PC1/A1	PC1	A1
34	36	H5	A2	A2	PC2/A2	PC2	A2
35	37	J5	A3	A3	PC3/A3	PC3	A3
36	38	K5	A4	A4	PC4/A4	PC4	A4
37	39	L6	A5	A5	PC5/A5	PC5	A5
38	40	H6	A6	A6	PC6/A6	PC6	A6
39	41	H7	A7	A7	PC7/A7	PC7	A7
40	42	L7	V _{CC}	V _{CC}	V _{CC}	V _{CC}	V _{CC}
41	43	K6	A8	A8	PB0/A8	PB0	A8
42	44	J6	A9	A9	PB1/A9	PB1	A9
43	45	J7	A10	A10	PB2/A10	PB2	A10
44	46	L8	A11	A11	PB3/A11	PB3	A11
45	47	K7	A12	A12	PB4/A12	PB4	A12
46	48	K8	A13	A13	PB5/A13	PB5	A13
47	49	J9	A14	A14	PB6/A14	PB6	A14
48	50	K9	A15	A15	PB7/A15	PB7	A15
49	51	K10	V _{SS}	V _{SS}	V _{SS}	V _{SS}	V _{SS}
50	52	L10	A16	A16	PA0/A16	PA0	A16
51	53	K11	A17	A17	PA1/A17	PA1	A17
52	54	L11	A18	A18	PA2/A18	PA2	A18
53	55	J11	A19	A19	PA3/A19	PA3	NC
54	56	J8	P20/TIOCA3	P20/TIOCA3	P20/TIOCA3	P20/TIOCA3	OE
55	57	H11	P21/TIOCB3	P21/TIOCB3	P21/TIOCB3	P21/TIOCB3	CE
56	58	J10	P22/TIOCC3/ TMRI0	P22/TIOCC3/ TMRI0	P22/TIOCC3/ TMRI0	P22/TIOCC3/ TMRI0	WE
57	59	H9	MD0	MD0	MD0	MD0	V _{SS}
58	60	H10	MD1	MD1	MD1	MD1	V _{SS}
59	61	G11	P23/TIOCD3/ TMC10	P23/TIOCD3/ TMC10	P23/TIOCD3/ TMC10	P23/TIOCD3/ TMC10	V _{CC}

Pin No.			Pin Name				Flash Memory Programmer Mode
TFP-100B, TFP-100G	FP-100A	TLP-113V	Mode 4	Mode 5	Mode 6*1	Mode 7*1	
60	62	—	WDTOVF (FWE, EMLE, V _{CL})*2	WDTOVF (FWE, EMLE, V _{CL})*2	WDTOVF (FWE, EMLE, V _{CL})*2	WDTOVF (FWE, EMLE, V _{CL})*2	FWE, EMLE, V _{CL} *2
61	63	G10	MD2	MD2	MD2	MD2	V _{SS}
62	64	F11	$\overline{\text{RES}}$	$\overline{\text{RES}}$	$\overline{\text{RES}}$	$\overline{\text{RES}}$	$\overline{\text{RES}}$
63	65	F8	NMI	NMI	NMI	NMI	V _{CC}
64	66	E8	$\overline{\text{STBY}}$	$\overline{\text{STBY}}$	$\overline{\text{STBY}}$	$\overline{\text{STBY}}$	V _{CC}
65	67	E11	V _{CC}	V _{CC}	V _{CC}	V _{CC}	V _{CC}
66	68	F10	XTAL	XTAL	XTAL	XTAL	XTAL
67	69	F9	EXTAL	EXTAL	EXTAL	EXTAL	EXTAL
68	70	E9	V _{SS}	V _{SS}	V _{SS}	V _{SS}	V _{SS}
69	71	D11	PF7/ ϕ	PF7/ ϕ	PF7/ ϕ	PF7/ ϕ	NC
70	72	E10	PF6/ $\overline{\text{AS}}$	PF6/ $\overline{\text{AS}}$	PF6/ $\overline{\text{AS}}$	PF6	NC
71	73	D8	$\overline{\text{RD}}$	$\overline{\text{RD}}$	$\overline{\text{RD}}$	PF5	NC
72	74	C11	HWR	HWR	HWR	PF4	NC
73	75	C10	PF3/LWR/IRQ3	PF3/LWR/IRQ3	PF3/LWR/IRQ3	PF3/IRQ3	NC
74	76	B10	PF2/WAIT/ IRQ2/DREQO	PF2/WAIT/ IRQ2/DREQO	PF2/WAIT/ IRQ2/DREQO	PF2/IRQ2	V _{CC}
75	77	B11	PF1/BACK/ IRQ1/CS5	PF1/BACK/ IRQ1/CS5	PF1/BACK/ IRQ1/CS5	PF1/IRQ1	V _{SS}
76	78	A10	PF0/BREQ/ IRQ0/CS4	PF0/BREQ/ IRQ0/CS4	PF0/BREQ/ IRQ0/CS4	PF0/IRQ0	V _{SS}
77	79	A11	AV _{CC}	AV _{CC}	AV _{CC}	AV _{CC}	V _{CC}
78	80	A9	V _{ref}	V _{ref}	V _{ref}	V _{ref}	V _{CC}
79	81	D9	P40/AN0	P40/AN0	P40/AN0	P40/AN0	NC
80	82	A8	P41/AN1	P41/AN1	P41/AN1	P41/AN1	NC
81	83	B9	P42/AN2	P42/AN2	P42/AN2	P42/AN2	NC
82	84	C8	P43/AN3	P43/AN3	P43/AN3	P43/AN3	NC
83	85	B8	P44/AN4	P44/AN4	P44/AN4	P44/AN4	NC
84	86	A7	P45/AN5	P45/AN5	P45/AN5	P45/AN5	NC
85	87	D7	P46/AN6/DA0	P46/AN6/DA0	P46/AN6/DA0	P46/AN6/DA0	NC
86	88	C7	P47/AN7/DA1	P47/AN7/DA1	P47/AN7/DA1	P47/AN7/DA1	NC
87	89	B7	AV _{SS}	AV _{SS}	AV _{SS}	AV _{SS}	V _{SS}
88	90	A6	V _{SS}	V _{SS}	V _{SS}	V _{SS}	V _{SS}
89	91	D6	P24/TIOCA4/ TMR11	P24/TIOCA4/ TMR11	P24/TIOCA4/ TMR11	P24/TIOCA4/ TMR11	NC

Pin No.			Pin Name				Flash Memory Programmer Mode
TFP-100B, TFP-100G	FP-100A	TLP-113V	Mode 4	Mode 5	Mode 6 ^{*1}	Mode 7 ^{*1}	
90	92	D5	P25/TIOCB4/ TMC11	P25/TIOCB4/ TMC11	P25/TIOCB4/ TMC11	P25/TIOCB4/ TMC11	V _{SS}
91	93	A5	P26/TIOCA5/ TMO0	P26/TIOCA5/ TMO0	P26/TIOCA5/ TMO0	P26/TIOCA5/ TMO0	NC
92	94	B6	P27/TIOCB5/ TMO1	P27/TIOCB5/ TMO1	P27/TIOCB5/ TMO1	P27/TIOCB5/ TMO1	NC
93	95	C6	PG0/IRQ6/ ADTRG	PG0/IRQ6/ ADTRG	PG0/IRQ6/ ADTRG	PG0/IRQ6/ ADTRG	NC
94	96	C5	PG1/CS3/ IRQ7/CS6	PG1/CS3/ IRQ7/CS6	PG1/CS3/ IRQ7/CS6	PG1/IRQ7	NC
95	97	A4	PG2/CS2	PG2/CS2	PG2/CS2	PG2	NC
96	98	A3	PG3/CS1/CS7	PG3/CS1/CS7	PG3/CS1/CS7	PG3	NC
97	99	B4	PG4/CS0	PG4/CS0	PG4/CS0	PG4	NC
98	100	B3	V _{CC}	V _{CC}	V _{CC}	V _{CC}	V _{CC}
99	1	B2	P10/TIOCA0/A20	P10/TIOCA0/A20	P10/TIOCA0/A20	P10/TIOCA0	NC
100	2	A2	P11/TIOCB0/A21	P11/TIOCB0/A21	P11/TIOCB0/A21	P11/TIOCB0	NC
—	—	A1, B5, C3, C9, D4, D10, E5, H2, H8, J1, L9	NC	NC	NC	NC	NC
—	—	K3	VSS	VSS	VSS	VSS	VSS
—	—	G8	V _{CL} (NC) ^{*3}	V _{CL} (NC) ^{*3}	V _{CL} (NC) ^{*3}	V _{CL} (NC) ^{*3}	V _{CL} (NC) ^{*3}
—	—	G9	NC (WDTOVF) ^{*3}	NC (WDTOVF) ^{*3}	NC (WDTOVF) ^{*3}	NC (WDTOVF) ^{*3}	NC

- Notes: 1. Only modes 4 and 5 are available in the ROMless version.
2. The FWE pin function is only available in the H8S/2318 F-ZTAT, H8S/2317 F-ZTAT, H8S/2315 F-ZTAT, and H8S/2314 F-ZTAT.
The EMLE pin function is only available in the H8S/2319 F-ZTAT.
The V_{CL} pin function is only available in the H8S/2319C F-ZTAT.
It cannot be used as a WDTOVF pin in the F-ZTAT versions.
3. Items in parentheses () indicate pin names on the H8S/2316S and H8S/2317S.

1.3.3 Pin Functions

Table 1.3 Pin Functions

Type	Symbol	Pin No.			I/O	Name and Function
		TFP-100B, TFP-100G	FP-100A	TLP-113V		
Power supply	V _{CC}	40, 65, 98	42, 67, 100	B3, E11, L7	Input	Power supply: For connection to the power supply. All V _{CC} pins should be connected to the system power supply.
	V _{SS}	7, 18, 31, 49, 68, 88	9, 20, 33, 51, 70, 90	A6, D2, E9, G3, J4, K3, K10	Input	Ground: For connection to ground (0 V). All V _{SS} pins should be connected to the system power supply (0 V).
Internal voltage step-down pin	V _{CL} ^{*1}	60	62	G8	Output	An external capacitor should be connected between this pin and GND (0 V). Do not connect it to V _{CC} .
Clock	XTAL	66	68	F10	Input	Connects to a crystal oscillator. See section 18, Clock Pulse Generator, for typical connection diagrams for a crystal oscillator and external clock input.
	EXTAL	67	69	F9	Input	Connects to a crystal oscillator. The EXTAL pin can also input an external clock. See section 18, Clock Pulse Generator, for typical connection diagrams for a crystal oscillator and external clock input.
	φ	69	71	D11	Output	System clock: Supplies the system clock to an external device.

Type	Symbol	Pin No.			I/O	Name and Function																																																												
		TFP-100B, TFP-100G	FP-100A	TLP-113V																																																														
Operating mode control	MD2 to MD0	61, 58, 57	63, 60, 59	G10, H10, H9	Input	<p>Mode pins: These pins set the operating mode.</p> <p>The relation between the settings of pins MD2 to MD0 and the operating mode is shown below. These pins should not be changed while the H8S/2319 Group is operating.</p> <ul style="list-style-type: none"> H8S/2318 F-ZTAT, H8S/2317 F-ZTAT, H8S/2315 F-ZTAT, and H8S/2314 F-ZTAT <table border="1"> <thead> <tr> <th>FWE</th> <th>MD2</th> <th>MD1</th> <th>MD0</th> <th>Operating Mode</th> </tr> </thead> <tbody> <tr> <td rowspan="3">0</td> <td rowspan="3">0</td> <td>0</td> <td>1</td> <td>—</td> </tr> <tr> <td>1</td> <td>0</td> <td>—</td> </tr> <tr> <td>1</td> <td>1</td> <td>—</td> </tr> <tr> <td rowspan="4">1</td> <td rowspan="4">0</td> <td>0</td> <td>0</td> <td>Mode 4</td> </tr> <tr> <td>1</td> <td>0</td> <td>Mode 5</td> </tr> <tr> <td>1</td> <td>0</td> <td>Mode 6</td> </tr> <tr> <td>1</td> <td>1</td> <td>Mode 7</td> </tr> <tr> <td rowspan="6">1</td> <td rowspan="3">0</td> <td>0</td> <td>0</td> <td>—</td> </tr> <tr> <td>1</td> <td>1</td> <td>—</td> </tr> <tr> <td>1</td> <td>0</td> <td>Mode 10</td> </tr> <tr> <td rowspan="3">1</td> <td rowspan="3">0</td> <td>1</td> <td>0</td> <td>Mode 11</td> </tr> <tr> <td>1</td> <td>0</td> <td>—</td> </tr> <tr> <td>1</td> <td>1</td> <td>—</td> </tr> <tr> <td rowspan="2">1</td> <td rowspan="2">0</td> <td>1</td> <td>0</td> <td>Mode 14</td> </tr> <tr> <td>1</td> <td>1</td> <td>Mode 15</td> </tr> </tbody> </table>	FWE	MD2	MD1	MD0	Operating Mode	0	0	0	1	—	1	0	—	1	1	—	1	0	0	0	Mode 4	1	0	Mode 5	1	0	Mode 6	1	1	Mode 7	1	0	0	0	—	1	1	—	1	0	Mode 10	1	0	1	0	Mode 11	1	0	—	1	1	—	1	0	1	0	Mode 14	1	1	Mode 15
FWE	MD2	MD1	MD0	Operating Mode																																																														
0	0	0	1	—																																																														
		1	0	—																																																														
		1	1	—																																																														
1	0	0	0	Mode 4																																																														
		1	0	Mode 5																																																														
		1	0	Mode 6																																																														
		1	1	Mode 7																																																														
1	0	0	0	—																																																														
		1	1	—																																																														
		1	0	Mode 10																																																														
	1	0	1	0	Mode 11																																																													
			1	0	—																																																													
			1	1	—																																																													
1	0	1	0	Mode 14																																																														
		1	1	Mode 15																																																														

Type	Symbol	Pin No.			I/O	Name and Function								
		TFP-100B, TFP-100G	FP-100A	TLP-113V										
Operating mode control	MD2 to MD0	61, 58, 57	63, 60, 59	G10, H10, H9	Input	<ul style="list-style-type: none"> Mask ROM and ROMless versions, H8S/2319 F-ZTAT, and H8S/2319C F-ZTAT 								
											Operating Mode			
											MD2	MD1	MD0	
											0	0	1	Mode 1* ¹
												1	0	Mode 2* ²
													1	Mode 2* ²
											1	0	0	Mode 4* ³
													1	Mode 5* ³
												1	0	Mode 6
													1	Mode 7
System control	$\overline{\text{RES}}$	62	64	F11	Input	Reset input: When this pin is driven low, the chip is reset.								
	$\overline{\text{STBY}}$	64	66	E8	Input	Standby: When this pin is driven low, a transition is made to hardware standby mode.								
	$\overline{\text{BREQ}}$	76	78	A10	Input	Bus request: Used by an external bus master to issue a bus request to the H8S/2319 Group.								
	$\overline{\text{BREQO}}$	74	76	B10	Output	Bus request output: External bus request signal used when an internal bus master accesses external space in the external-bus-released state.								
	$\overline{\text{BACK}}$	75	77	B11	Output	Bus request acknowledge: Indicates that the bus has been released to an external bus master.								
	$\overline{\text{FWE}}$ * ⁴	60	62	—	Input	Flash write enable: Enables or disables writing to flash memory.								
	$\overline{\text{EMLE}}$ * ⁵	60	62	—	Input	Emulator enable: For connection to ground (0 V).								

Type	Symbol	Pin No.			I/O	Name and Function
		TFP-100B, TFP-100G	FP-100A	TLP-113V		
Interrupts	NMI	63	65	F8	Input	Nonmaskable interrupt: Requests a nonmaskable interrupt. When this pin is not used, it should be fixed high.
	$\overline{\text{IRQ7}}$ to $\overline{\text{IRQ0}}$	94, 93, 13, 12, 73 to 76	96, 95, 15, 14, 75 to 78	C5, C6, F4, F1, C10, B10, B11, A10	Input	Interrupt request 7 to 0: These pins request a maskable interrupt.
Address bus	A23 to A0	2, 1, 100, 99, 53 to 50, 48 to 41, 39 to 32	4 to 1, 55 to 52, 50 to 43, 41 to 34	C1, B1, A2, B2, J11, L11, K11, L10, K9, J9, K8, K7, L8, J7, J6, K6, H7, H6, L6, K5, J5, H5, L5, K4	Output	Address bus: These pins output an address.
Data bus	D15 to D0	30 to 19, 17 to 14	32 to 21, 19 to 16	L4, H3, L3, L1, L2, K1, K2, J2, J3, H4, G2, H1, F3, F2, G1, G4	I/O	Data bus: These pins constitute a bidirectional data bus.
Bus control	$\overline{\text{CS7}}$ to $\overline{\text{CS0}}$	94 to 97 75, 76	96 to 99 77, 78	A3, C5, B11, A10, A4, B4	Output	Chip select: Signals for selecting areas 7 to 0.
	$\overline{\text{AS}}$	70	72	E10	Output	Address strobe: When this pin is low, it indicates that address output on the address bus is enabled.
	$\overline{\text{RD}}$	71	73	D8	Output	Read: When this pin is low, it indicates that the external address space can be read.
	$\overline{\text{HWR}}$	72	74	C11	Output	High write: A strobe signal that writes to external space and indicates that the upper half (D15 to D8) of the data bus is enabled.
	$\overline{\text{LWR}}$	73	75	C10	Output	Low write: A strobe signal that writes to external space and indicates that the lower half (D7 to D0) of the data bus is enabled.

Type	Symbol	Pin No.			I/O	Name and Function
		TFP-100B, TFP-100G	FP-100A	TLP-113V		
Bus control	WAIT	74	76	B10	Input	Wait: Requests insertion of a wait state in the bus cycle when accessing external 3-state access space.
16-bit timer-pulse unit (TPU)	TCLKD to TCLKA	6, 4, 2, 1	8, 6, 4, 3	D3, D1, C1, B1	Input	Clock input D to A: These pins input an external clock.
	TIOCA0, TIOCB0, TIOCC0, TIOCD0	99, 100, 1, 2	1 to 4	B2, A2, B1, C1	I/O	Input capture/ output compare match A0 to D0: The TGR0A to TGR0D input capture input or output compare output, or PWM output pins.
	TIOCA1, TIOCB1	3, 4	5, 6	C4, D1	I/O	Input capture/ output compare match A1 and B1: The TGR1A and TGR1B input capture input or output compare output, or PWM output pins.
	TIOCA2, TIOCB2	5, 6	7, 8	C2, D3	I/O	Input capture/ output compare match J8, H11, J10, G11A2 and B2: The TGR2A and TGR2B input capture input or output compare output, or PWM output pins.
	TIOCA3, TIOCB3, TIOCC3, TIOCD3	54 to 56, 59	56 to 58, 61	J8, H11, J10, G11	I/O	Input capture/ output compare match A3 to D3: The TGR3A to TGR3D input capture input or output compare output, or PWM output pins.
	TIOCA4, TIOCB4	89, 90	91, 92	D6, D5	I/O	Input capture/ output compare match A4 and B4: The TGR4A and TGR4B input capture input or output compare output, or PWM output pins.
	TIOCA5, TIOCB5	91, 92	93, 94	A5, B6	I/O	Input capture/ output compare match A5 and B5: The TGR5A and TGR5B input capture input or output compare output, or PWM output pins.
8-bit timer	TMO0, TMO1	91, 92	93, 94	A5, B6	Output	Compare match output: The compare match output pins.
	TMCI0, TMCI1	59, 90	61, 92	G11, D5	Input	Counter external clock input: Input pins for the external clock input to the counter.
	TMRI0, TMRI1	56, 89	58, 91	J10, D6	Input	Counter external reset input: The counter reset input pins.

Type	Symbol	Pin No.			I/O	Name and Function
		TFP-100B, TFP-100G	FP-100A	TLP-113V		
Watchdog timer (WDT)	WDTOVF*6	60	62	G9	Output	Watchdog timer overflows: The counter overflows signal output pin in watchdog timer mode.
Serial communication interface (SCI) Smart Card interface	TxD1, TxD0	9, 8	11, 10	E4, E1	Output	Transmit data (channel 0, 1): Data output pins.
	RxD1, RxD0	11, 10	13, 12	E2, E3	Input	Receive data (channel 0, 1): Data input pins.
	SCK1 SCK0	13, 12	15, 14	F1, F4	I/O	Serial clock (channel 0, 1): Clock I/O pins.
A/D converter	AN7 to AN0	86 to 79	88 to 81	D7, C7, A7, B8, C8, B9, A8, D9	Input	Analog 7 to 0: Analog input pins.
	ADTRG	93	95	C6	Input	A/D conversion external trigger input: Pin for input of an external trigger to start A/D conversion.
D/A converter	DA1, DA0	86, 85	88, 87	D7, C7	Output	Analog output: D/A converter analog output pins.
A/D converter and D/A converter	AV _{CC}	77	79	A11	Input	This is the power supply pin for the A/D converter and D/A converter. When the A/D converter and D/A converter are not used, this pin should be connected to the system power supply (V _{CC}).
	AV _{SS}	87	89	B7	Input	This is the ground pin for the A/D converter and D/A converter. This pin should be connected to the system power supply (0 V).
	V _{ref}	78	80	A9	Input	This is the reference voltage input pin for the A/D converter and D/A converter. When the A/D converter and D/A converter are not used, this pin should be connected to the system power supply (V _{CC}).

Type	Symbol	Pin No.			I/O	Name and Function
		TFP-100B, TFP-100G	FP-100A	TLP-113V		
I/O ports	P17 to P10	6 to 1, 99	8 to 1	D3, C2, D1, C4, C1, B1, A2, B2	I/O	Port 1: An 8-bit I/O port. Input or output can be designated for each bit by means of the port 1 data direction register (P1DDR).
	P27 to P20	92 to 89, 59, 56 to 54	94 to 91, 61, 58 to 56	B6, A5, D5, D6, G11, J10, H11, J8	I/O	Port 2: An 8-bit I/O port. Input or output can be designated for each bit by means of the port 2 data direction register (P2DDR).
	P35 to P30	13 to 8	15 to 10	F4, F1, E2, E3, E4, E1	I/O	Port 3: A 6-bit I/O port. Input or output can be designated for each bit by means of the port 3 data direction register (P3DDR).
	P47 to P40	86 to 79	88 to 81	D7, C7, A7, B8, C8, B9, A8, D9	Input	Port 4: An 8-bit input port.
	PA3 to PA0	53 to 50	55 to 52	J11, L11, K11, L10	I/O	Port A ^{*7} : A 4-bit I/O port. Input or output can be designated for each bit by means of the port A data direction register (PADDR).
	PB7 to PB0	48 to 41	50 to 43	K9, J9, K8, K7, L8, J7, J6, K6	I/O	Port B ^{*7} : An 8-bit I/O port. Input or output can be designated for each bit by means of the port B data direction register (PBDDR).
	PC7 to PC0	39 to 32	41 to 34	H7, H6, L6, K5, J5, H5, L5, K4	I/O	Port C ^{*7} : An 8-bit I/O port. Input or output can be designated for each bit by means of the port C data direction register (PCDDR).
	PD7 to PD0	30 to 23	32 to 25	L4, H3, L3, L1, L2, K1, K2, J2	I/O	Port D ^{*7} : An 8-bit I/O port. Input or output can be designated for each bit by means of the port D data direction register (PDDDR).
	PE7 to PE0	22 to 19, 17 to 14	24 to 21, 19 to 16	J3, H4, G2, H1, F3, F2, G1, G4	I/O	Port E: An 8-bit I/O port. Input or output can be designated for each bit by means of the port E data direction register (PEDDR).

Type	Symbol	Pin No.			I/O	Name and Function
		TFP-100B, TFP-100G	FP-100A	TLP-113V		
I/O ports	PF7 to PF0	69 to 76	71 to 78	D11, E10, D8, C11, C10, B10, B11, A10	I/O	Port F: An 8-bit I/O port. Input or output can be designated for each bit by means of the port F data direction register (PFDDR).
	PG4 to PG0	97 to 93	99 to 95	B4, A3, A4, C5, C6	I/O	Port G: A 5-bit I/O port. Input or output can be designated for each bit by means of the port G data direction register (PGDDR).

- Notes:
1. Applies to the H8S/2319C F-ZTAT only.
 2. Applies to the H8S/2319 F-ZTAT and H8S/2319C F-ZTAT only.
 3. Only modes 4 and 5 are available in the ROMless versions.
 4. Applies to the H8S/2318 F-ZTAT, H8S/2317 F-ZTAT, H8S/2315 F-ZTAT, and H8S/2314 F-ZTAT only.
 5. Applies to the H8S/2319 F-ZTAT only.
 6. Applies to mask ROM and ROMless versions only.
Cannot be used as an I/O port in the ROMless versions.

Section 2 CPU

2.1 Overview

The H8S/2000 CPU is a high-speed central processing unit with an internal 32-bit architecture that is upward-compatible with the H8/300 and H8/300H CPUs. The H8S/2000 CPU has sixteen 16-bit general registers, can address a 16-Mbyte (4-Gbyte architecturally) linear address space, and is ideal for realtime control.

2.1.1 Features

The H8S/2000 CPU has the following features.

- Upward-compatible with H8/300 and H8/300H CPUs
 - Can execute H8/300 and H8/300H object programs
- General-register architecture
 - Sixteen 16-bit general registers (also usable as sixteen 8-bit registers or eight 32-bit registers)
- Sixty-five basic instructions
 - 8/16/32-bit arithmetic and logic instructions
 - Multiply and divide instructions
 - Powerful bit-manipulation instructions
- Eight addressing modes
 - Register direct [Rn]
 - Register indirect [@ERn]
 - Register indirect with displacement [@(d:16,ERn) or @(d:32,ERn)]
 - Register indirect with post-increment or pre-decrement [@ERn+ or @-ERn]
 - Absolute address [@aa:8, @aa:16, @aa:24, or @aa:32]
 - Immediate [#xx:8, #xx:16, or #xx:32]
 - Program-counter relative [@(d:8,PC) or @(d:16,PC)]
 - Memory indirect [@@aa:8]
- 16-Mbyte address space
 - Program: 16 Mbytes
 - Data: 16 Mbytes (4 Gbytes architecturally)

- High-speed operation
 - All frequently-used instructions execute in one or two states
 - Maximum clock rate : 25 MHz
 - 8/16/32-bit register-register add/subtract : 40 ns
 - 8×8 -bit register-register multiply : 480 ns
 - $16 \div 8$ -bit register-register divide : 480 ns
 - 16×16 -bit register-register multiply : 800 ns
 - $32 \div 16$ -bit register-register divide : 800 ns
- CPU operating mode
 - Advanced mode
- Power-down state
 - Transition to power-down state by SLEEP instruction
 - CPU clock speed selection

2.1.2 Differences between H8S/2600 CPU and H8S/2000 CPU

The differences between the H8S/2600 CPU and the H8S/2000 CPU are as shown below.

- Register configuration
 - The MAC register is supported only by the H8S/2600 CPU.
- Basic instructions
 - The four instructions MAC, CLRMAC, LDMAC, and STMAC are supported only by the H8S/2600 CPU.
- Number of execution states
 - The number of execution states of the MULXU and MULXS instructions.

Instruction	Mnemonic	Internal Operation	
		H8S/2600	H8S/2000
MULXU	MULXU.B Rs, Rd	3	12
	MULXU.W Rs, ERd	4	20
MULXS	MULXS.B Rs, Rd	4	13
	MULXS.W Rs, ERd	5	21

There are also differences in the address space, CCR and EXR functions, power-down state, etc., depending on the product.

2.1.3 Differences from H8/300 CPU

In comparison to the H8/300 CPU, the H8S/2000 CPU has the following enhancements.

- More general registers and control registers
 - Eight 16-bit expanded registers, and one 8-bit control register, have been added.
- Expanded address space
 - Advanced mode supports a maximum 16-Mbyte address space.
- Enhanced addressing
 - The addressing modes have been enhanced to make effective use of the 16-Mbyte address space.
- Enhanced instructions
 - Addressing modes of bit-manipulation instructions have been enhanced.
 - Signed multiply and divide instructions have been added.
 - Two-bit shift instructions have been added.
 - Instructions for saving and restoring multiple registers have been added.
 - A test and set instruction has been added.
- Higher speed
 - Basic instructions execute twice as fast.

2.1.4 Differences from H8/300H CPU

In comparison to the H8/300H CPU, the H8S/2000 CPU has the following enhancements.

- Additional control register
 - One 8-bit control register has been added.
- Enhanced instructions
 - Addressing modes of bit-manipulation instructions have been enhanced.
 - Two-bit shift instructions have been added.
 - Instructions for saving and restoring multiple registers have been added.
 - A test and set instruction has been added.
- Higher speed
 - Basic instructions execute twice as fast.

2.2 CPU Operating Modes

The H8S/2319 Group CPU has advanced operating mode. Advanced mode supports a maximum 16-Mbyte total address space (architecturally a maximum 16-Mbyte program area and a maximum of 4 Gbytes for program and data areas combined). The mode is selected by the mode pins of the microcontroller.

Advanced Mode

Address Space: Linear access is provided to a 16-Mbyte maximum address space (architecturally a maximum 16-Mbyte program area and a maximum 4-Gbyte data area, with a maximum of 4 Gbytes for program and data areas combined).

Extended Registers (En): The extended registers (E0 to E7) can be used as 16-bit registers, or as the upper 16-bit segments of 32-bit registers or address registers.

Instruction Set: All instructions and addressing modes can be used.

Exception Vector Table and Memory Indirect Branch Addresses: In advanced mode the top area starting at H'00000000 is allocated to the exception vector table in units of 32 bits. In each 32 bits, the upper 8 bits are ignored and a branch address is stored in the lower 24 bits (figure 2.1). For details of the exception vector table, see section 4, Exception Handling.

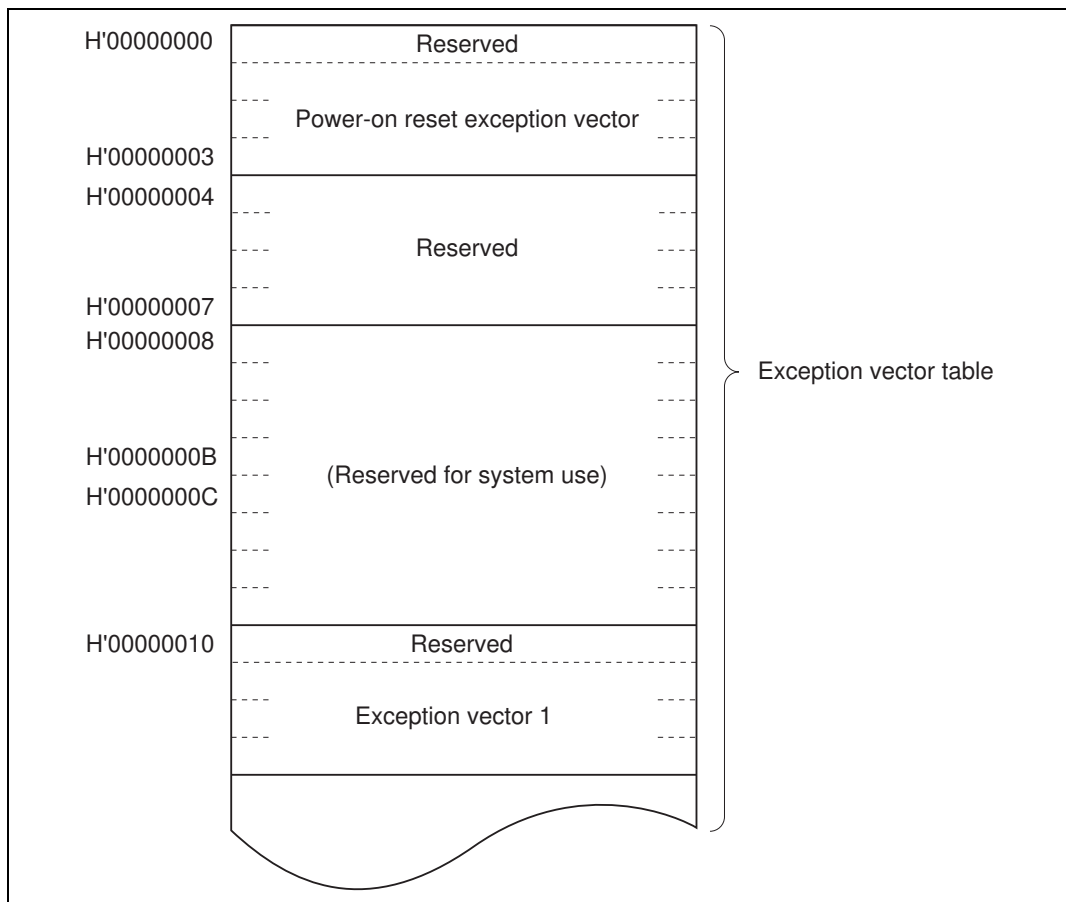

Figure 2.1 Exception Vector Table (Advanced Mode)

The memory indirect addressing mode (@@aa:8) employed in the JMP and JSR instructions uses an 8-bit absolute address included in the instruction code to specify a memory operand that contains a branch address. In advanced mode the operand is a 32-bit longword operand, providing a 32-bit branch address. The upper 8 bits of these 32 bits are a reserved area that is regarded as H'00. Branch addresses can be stored in the area from H'00000000 to H'000000FF. Note that the first part of this range is also the exception vector table.

Stack Structure: In advanced mode, when the program counter (PC) is pushed onto the stack in a subroutine call, and the PC, condition-code register (CCR), and extended control register (EXR) are pushed onto the stack in exception handling, they are stored as shown in figure 2.2. When EXR is invalid, it is not pushed onto the stack. For details, see section 4, Exception Handling.

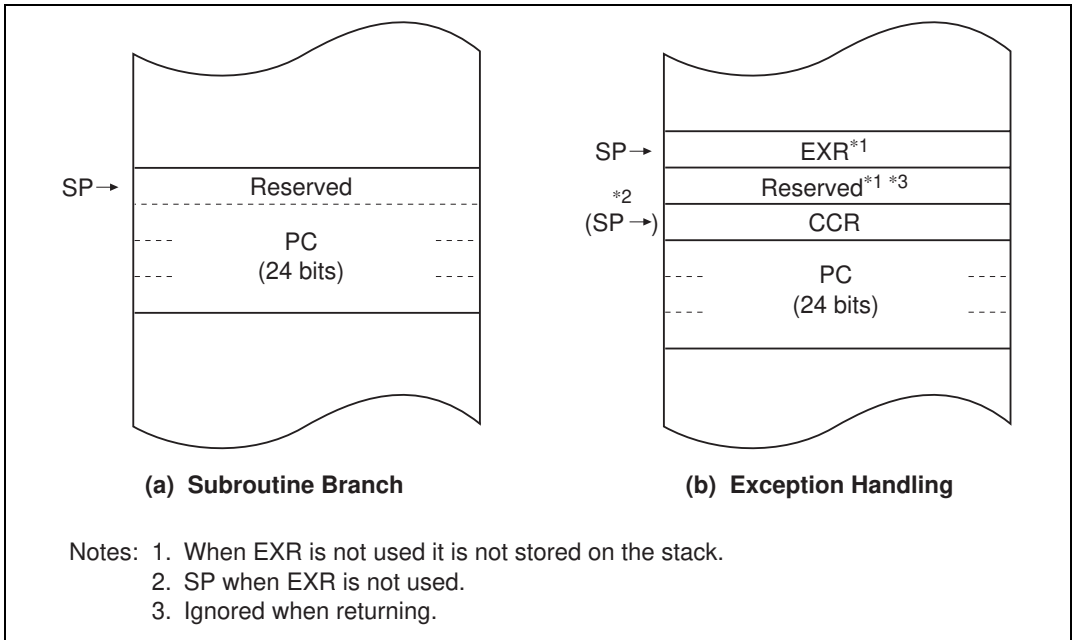

Figure 2.2 Stack Structure in Advanced Mode

2.3 Address Space

Figure 2.3 shows a memory map of the H8S/2000 CPU. The H8S/2000 CPU provides linear access to a maximum 16-Mbyte (4-Gbyte architecturally) address space in advanced mode.

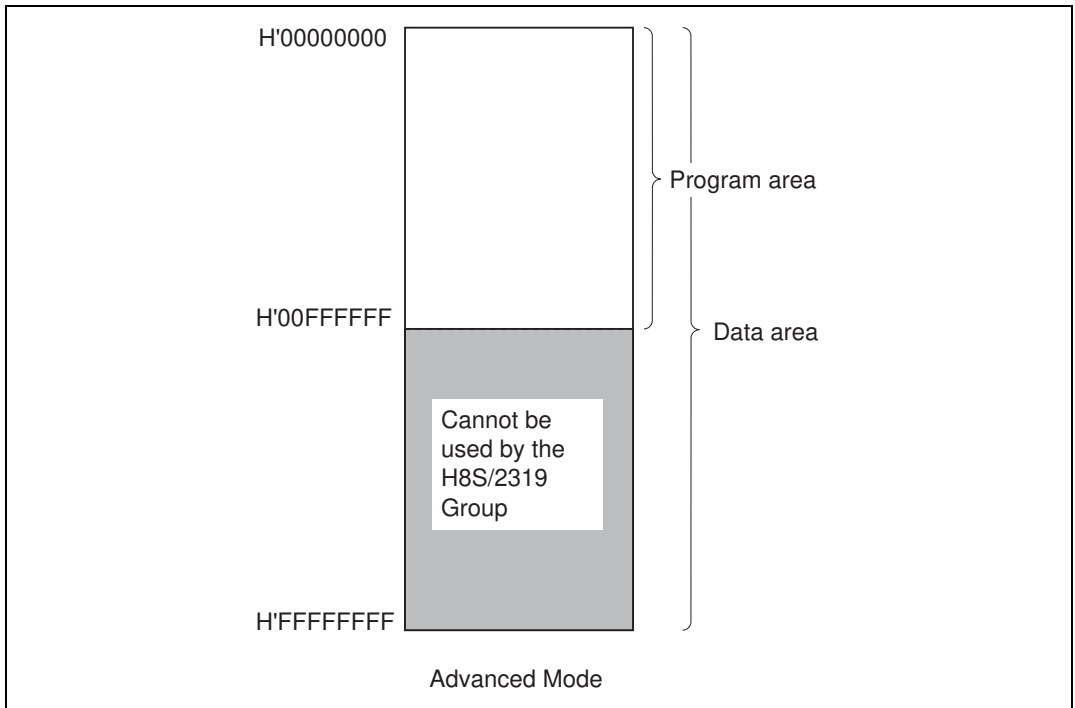

Figure 2.3 Memory Map

2.4 Register Configuration

2.4.1 Overview

The CPU has the internal registers shown in figure 2.4. There are two types of registers: general registers and control registers.

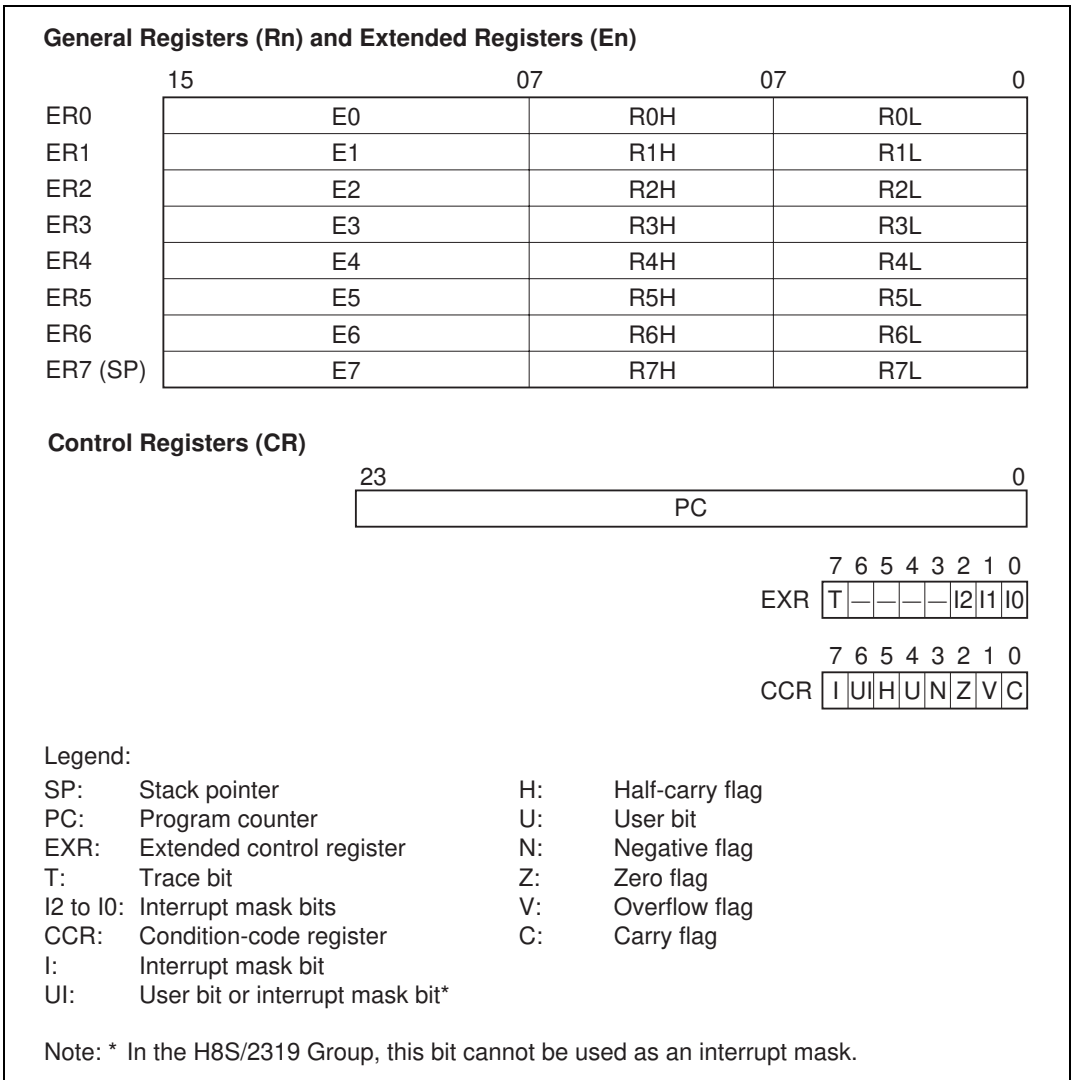

Figure 2.4 CPU Registers

2.4.2 General Registers

The CPU has eight 32-bit general registers. These general registers are all functionally alike and can be used as both address registers and data registers. When a general register is used as a data register, it can be accessed as a 32-bit, 16-bit, or 8-bit register. When the general registers are used as 32-bit registers or address registers, they are designated by the letters ER (ER0 to ER7).

The ER registers divide into 16-bit general registers designated by the letters E (E0 to E7) and R (R0 to R7). These registers are functionally equivalent, providing a maximum sixteen 16-bit registers. The E registers (E0 to E7) are also referred to as extended registers.

The R registers divide into 8-bit general registers designated by the letters RH (R0H to R7H) and RL (R0L to R7L). These registers are functionally equivalent, providing a maximum sixteen 8-bit registers.

Figure 2.5 illustrates the usage of the general registers. The usage of each register can be selected independently.

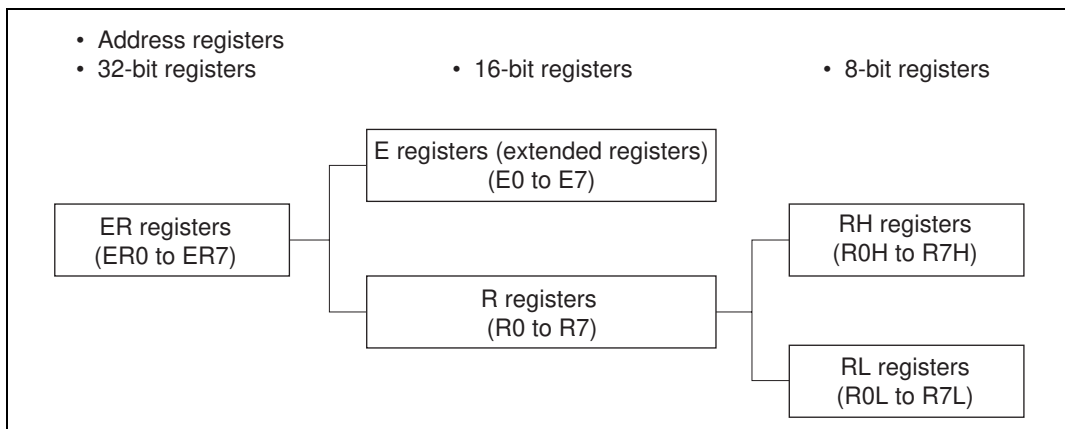

Figure 2.5 Usage of General Registers

General register ER7 has the function of stack pointer (SP) in addition to its general-register function, and is used implicitly in exception handling and subroutine calls. Figure 2.6 shows the stack.

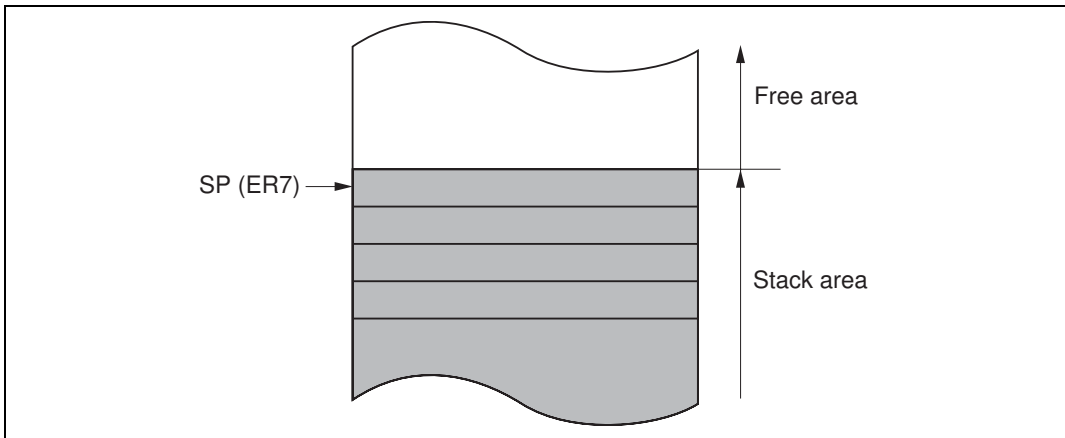

Figure 2.6 Stack

2.4.3 Control Registers

The control registers are the 24-bit program counter (PC), 8-bit extended control register (EXR), and 8-bit condition-code register (CCR).

(1) Program Counter (PC)

This 24-bit counter indicates the address of the next instruction the CPU will execute. The length of all CPU instructions is 2 bytes (one word), so the least significant PC bit is ignored (When an instruction is fetched, the least significant PC bit is regarded as 0).

(2) Extended Control Register (EXR)

This 8-bit register contains the trace bit (T) and three interrupt mask bits (I2 to I0).

Bit 7—Trace Bit (T): Selects trace mode. When this bit is cleared to 0, instructions are executed in sequence. When this bit is set to 1, a trace exception is generated each time an instruction is executed.

Bits 6 to 3—Reserved: These bits are reserved. They are always read as 1.

Bits 2 to 0—Interrupt Mask Bits (I2 to I0): These bits designate the interrupt mask level (0 to 7). For details, refer to section 5, Interrupt Controller.

Operations can be performed on the EXR bits by the LDC, STC, ANDC, ORC, and XORC instructions. All interrupts, including NMI, are disabled for three states after one of these instructions is executed, except for STC.

(3) Condition-Code Register (CCR)

This 8-bit register contains internal CPU status information, including an interrupt mask bit (I) and half-carry (H), negative (N), zero (Z), overflow (V), and carry (C) flags.

Bit 7—Interrupt Mask Bit (I): Masks interrupts other than NMI when set to 1. (NMI is accepted regardless of the I bit setting.) The I bit is set to 1 by hardware at the start of an exception-handling sequence. For details, refer to section 5, Interrupt Controller.

Bit 6—User Bit or Interrupt Mask Bit (UI): Can be written and read by software using the LDC, STC, ANDC, ORC, and XORC instructions. With the H8S/2319 Group, this bit cannot be used as an interrupt mask bit.

Bit 5—Half-Carry Flag (H): When the ADD.B, ADDX.B, SUB.B, SUBX.B, CMP.B, or NEG.B instruction is executed, this flag is set to 1 if there is a carry or borrow at bit 3, and cleared to 0 otherwise. When the ADD.W, SUB.W, CMP.W, or NEG.W instruction is executed, the H flag is set to 1 if there is a carry or borrow at bit 11, and cleared to 0 otherwise. When the ADD.L, SUB.L, CMP.L, or NEG.L instruction is executed, the H flag is set to 1 if there is a carry or borrow at bit 27, and cleared to 0 otherwise.

Bit 4—User Bit (U): Can be written and read by software using the LDC, STC, ANDC, ORC, and XORC instructions.

Bit 3—Negative Flag (N): Stores the value of the most significant bit (sign bit) of data.

Bit 2—Zero Flag (Z): Set to 1 to indicate zero data, and cleared to 0 to indicate non-zero data.

Bit 1—Overflow Flag (V): Set to 1 when an arithmetic overflow occurs, and cleared to 0 at other times.

Bit 0—Carry Flag (C): Set to 1 when a carry occurs, and cleared to 0 otherwise. Used by:

- Add instructions, to indicate a carry
- Subtract instructions, to indicate a borrow
- Shift and rotate instructions, to store the value shifted out of the end bit

The carry flag is also used as a bit accumulator by bit manipulation instructions.

Some instructions leave some or all of the flag bits unchanged. For the action of each instruction on the flag bits, refer to appendix A.1, Instruction List.

Operations can be performed on the CCR bits by the LDC, STC, ANDC, ORC, and XORC instructions. The N, Z, V, and C flags are used as branching conditions for conditional branch (Bcc) instructions.

2.4.4 Initial Register Values

Reset exception handling loads the CPU's program counter (PC) from the vector table, clears the trace bit in EXR to 0, and sets the interrupt mask bits in CCR and EXR to 1. The other CCR bits and the general registers are not initialized. In particular, the stack pointer (ER7) is not initialized. The stack pointer should therefore be initialized by an MOV.L instruction executed immediately after a reset.

2.5 Data Formats

The CPU can process 1-bit, 4-bit (BCD), 8-bit (byte), 16-bit (word), and 32-bit (longword) data. Bit-manipulation instructions operate on 1-bit data by accessing bit n ($n = 0, 1, 2, \dots, 7$) of byte operand data. The DAA and DAS decimal-adjust instructions treat byte data as two digits of 4-bit BCD data.

2.5.1 General Register Data Formats

Figure 2.7 shows the data formats in general registers.

Data Type	Register Number	Data Format
1-bit data	RnH	
1-bit data	RnL	
4-bit BCD data	RnH	
4-bit BCD data	RnL	
Byte data	RnH	
Byte data	RnL	

Figure 2.7 General Register Data Formats

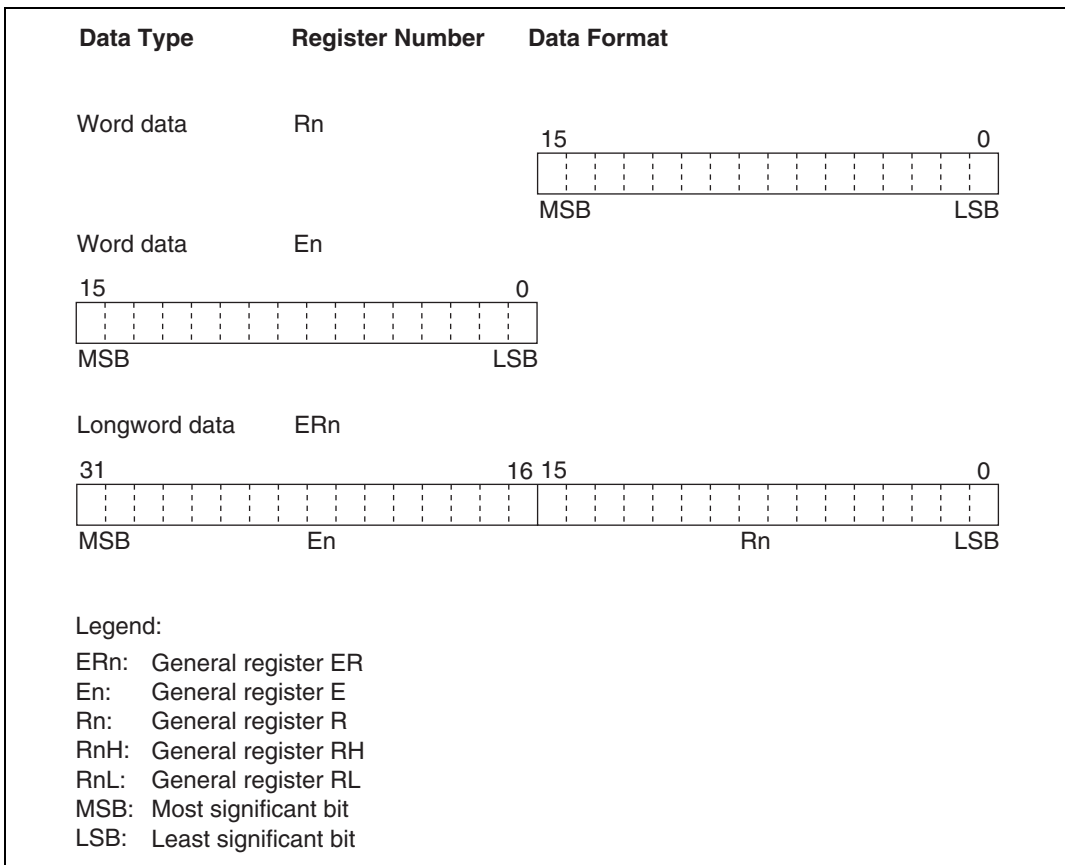

Figure 2.7 General Register Data Formats (cont)

2.5.2 Memory Data Formats

Figure 2.8 shows the data formats in memory. The CPU can access word data and longword data in memory, but word or longword data must begin at an even address. If an attempt is made to access word or longword data at an odd address, no address error occurs but the least significant bit of the address is regarded as 0, so the access starts at the preceding address. This also applies to instruction fetches.

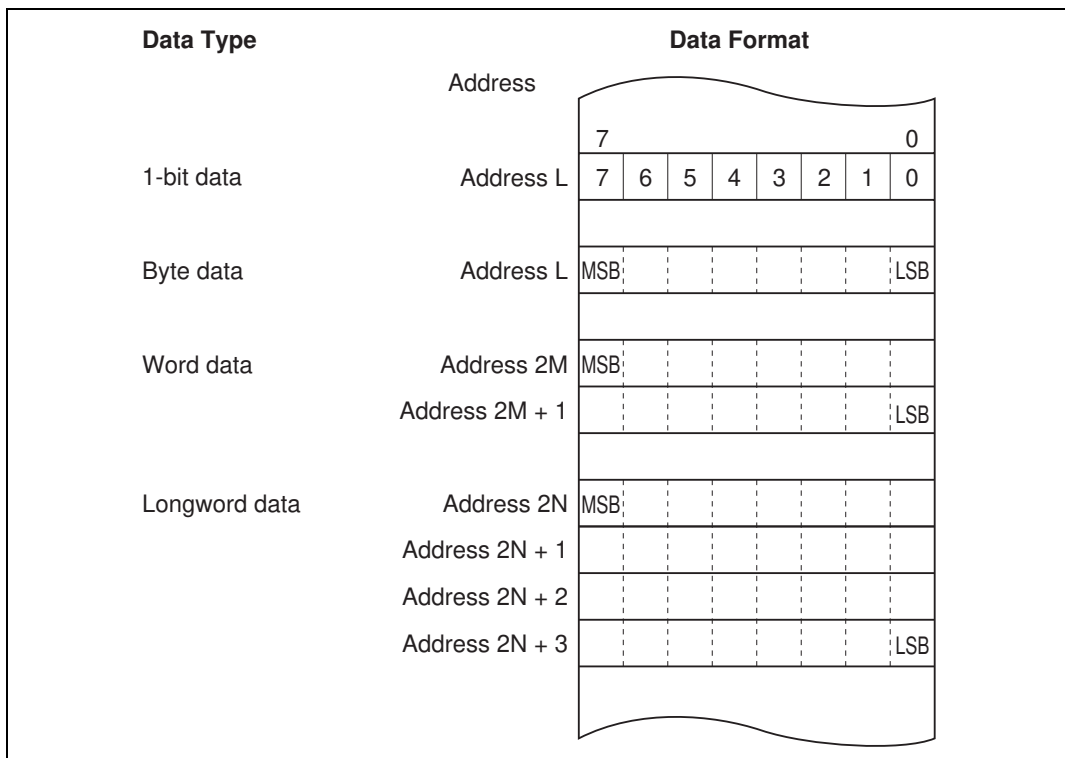

Figure 2.8 Memory Data Formats

When ER7 is used as an address register to access the stack, the operand size should be word size or longword size.

2.6 Instruction Set

2.6.1 Overview

The H8S/2000 CPU has 65 types of instructions. The instructions are classified by function in table 2.1.

Table 2.1 Instruction Classification

Function	Instructions	Size	Types
Data transfer	MOV	BWL	5
	POP ^{*1} , PUSH ^{*1}	WL	
	LDM, STM	L	
	MOVFP, MOVTPE ^{*3}	B	
Arithmetic operations	ADD, SUB, CMP, NEG	BWL	19
	ADDX, SUBX, DAA, DAS	B	
	INC, DEC	BWL	
	ADDS, SUBS	L	
	MULXU, DIVXU, MULXS, DIVXS	BW	
	EXTU, EXTS	WL	
	TAS ^{*4}	B	
Logic operations	AND, OR, XOR, NOT	BWL	4
Shift	SHAL, SHAR, SHLL, SHLR, ROTL, ROTR, ROTXL, ROTXR	BWL	8
Bit manipulation	BSET, BCLR, BNOT, BTST, BLD, BILD, BST, BIST, BAND, BIAND, BOR, BIOR, BXOR, BIXOR	B	14
Branch	Bcc ^{*2} , JMP, BSR, JSR, RTS	—	5
System control	TRAPA, RTE, SLEEP, LDC, STC, ANDC, ORC, XORC, NOP	—	9
Block data transfer	EEPMOV	—	1
		Total	65

Legend:

B: Byte

W: Word

L: Longword

- Notes:
1. POP.W Rn and PUSH.W Rn are identical to MOV.W @SP+, Rn and MOV.W Rn, @-SP. POP.L ERn and PUSH.L ERn are identical to MOV.L @SP+, ERn and MOV.L ERn, @-SP.
 2. Bcc is the general name for conditional branch instructions.
 3. Cannot be used in the H8S/2319 Group.
 4. Only register ER0, ER1, ER4, or ER5 should be used when using the TAS instruction.

2.6.2 Instructions and Addressing Modes

Table 2.2 indicates the combinations of instructions and addressing modes that the H8S/2600 CPU can use.

Table 2.2 Combinations of Instructions and Addressing Modes

Function	Instruction	Addressing Modes													
		#xx	Rn	@ERn	@(d:16,ERn)	@(d:32,ERn)	@ERn@ERn+	@aa:8	@aa:16	@aa:24	@aa:32	@(d:8,PC)	@(d:16,PC)	@@aa:8	—
Data transfer	MOV	BWL	BWL	BWL	BWL	BWL	BWL	B	BWL	—	BWL	—	—	—	—
	POP, PUSH	—	—	—	—	—	—	—	—	—	—	—	—	—	WL
	LDM, STM	—	—	—	—	—	—	—	—	—	—	—	—	—	L
	MOVFP, MOVTP ¹	—	—	—	—	—	—	—	B	—	—	—	—	—	—
Arithmetic operations	ADD, CMP	BWL	BWL	—	—	—	—	—	—	—	—	—	—	—	—
	SUB	WL	BWL	—	—	—	—	—	—	—	—	—	—	—	—
	ADDX, SUBX	B	B	—	—	—	—	—	—	—	—	—	—	—	—
	ADDS, SUBS	—	L	—	—	—	—	—	—	—	—	—	—	—	—
	INC, DEC	—	BWL	—	—	—	—	—	—	—	—	—	—	—	—
	DAA, DAS	—	B	—	—	—	—	—	—	—	—	—	—	—	—
	MULXU, DIVXU	—	BW	—	—	—	—	—	—	—	—	—	—	—	—
	MULXS, DIVXS	—	BW	—	—	—	—	—	—	—	—	—	—	—	—
	NEG	—	BWL	—	—	—	—	—	—	—	—	—	—	—	—
	EXTU, EXTS	—	WL	—	—	—	—	—	—	—	—	—	—	—	—
TAS ²	—	—	B	—	—	—	—	—	—	—	—	—	—	—	
Logic operations	AND, OR, XOR	BWL	BWL	—	—	—	—	—	—	—	—	—	—	—	—
	NOT	—	BWL	—	—	—	—	—	—	—	—	—	—	—	—
Shift	—	BWL	—	—	—	—	—	—	—	—	—	—	—	—	
Bit manipulation	—	B	B	—	—	—	—	B	B	—	B	—	—	—	
Branch	Bcc, BSR	—	—	—	—	—	—	—	—	—	—	○	○	—	
	JMP, JSR	—	—	—	—	—	—	—	—	○	—	—	—	○	
	RTS	—	—	—	—	—	—	—	—	—	—	—	—	○	
System control	TRAPA	—	—	—	—	—	—	—	—	—	—	—	—	○	
	RTE	—	—	—	—	—	—	—	—	—	—	—	—	○	
	SLEEP	—	—	—	—	—	—	—	—	—	—	—	—	○	
	LDC	B	B	W	W	W	W	—	W	—	W	—	—	—	
	STC	—	B	W	W	W	W	—	W	—	W	—	—	—	
	ANDC, ORC, XORC	B	—	—	—	—	—	—	—	—	—	—	—	—	
	NOP	—	—	—	—	—	—	—	—	—	—	—	—	○	
Block data transfer	—	—	—	—	—	—	—	—	—	—	—	—	—	BW	

Legend:

Size refers to the operand size.

B: Byte

W: Word

L: Longword

Notes: 1. Cannot be used in the H8S/2319 Group.

2. Only register ER0, ER1, ER4, or ER5 should be used when using the TAS instruction.

2.6.3 Table of Instructions Classified by Function

Table 2.3 summarizes the instructions in each functional category. The notation used in table 2.3 is defined below.

Operation Notation

Rd	General register (destination)*
Rs	General register (source)*
Rn	General register*
ERn	General register (32-bit register)
(EAd)	Destination operand
(EAs)	Source operand
EXR	Extended control register
CCR	Condition-code register
N	N (negative) flag in CCR
Z	Z (zero) flag in CCR
V	V (overflow) flag in CCR
C	C (carry) flag in CCR
PC	Program counter
SP	Stack pointer
#IMM	Immediate data
disp	Displacement
+	Addition
−	Subtraction
×	Multiplication
÷	Division
^	Logical AND
∨	Logical OR
⊕	Logical exclusive OR
→	Move
¬	NOT (logical complement)
:8/:16/:24/:32	8-, 16-, 24-, or 32-bit length

Note: *General registers include 8-bit registers (R0H to R7H, R0L to R7L), 16-bit registers (R0 to R7, E0 to E7), and 32-bit registers (ER0 to ER7).

Table 2.3 Instructions Classified by Function

Type	Instruction	Size*1	Function
Data transfer	MOV	B/W/L	(EAs) → Rd, Rs → (Ead) Moves data between two general registers or between a general register and memory, or moves immediate data to a general register.
	MOVFP	B	Cannot be used in the H8S/2319 Group.
	MOVTP	B	Cannot be used in the H8S/2319 Group.
	POP	W/L	@SP+ → Rn Pops a register from the stack. POP.W Rn is identical to MOV.W @SP+, Rn. POP.L ERn is identical to MOV.L @SP+, ERn.
	PUSH	W/L	Rn → @-SP Pushes a register onto the stack. PUSH.W Rn is identical to MOV.W Rn, @-SP. PUSH.L ERn is identical to MOV.L ERn, @-SP.
	LDM	L	@SP+ → Rn (register list) Pops two or more general registers from the stack.
	STM	L	Rn (register list) → @-SP Pushes two or more general registers onto the stack.

Type	Instruction	Size*1	Function
Arithmetic operations	ADD SUB	B/W/L	$Rd \pm Rs \rightarrow Rd$, $Rd \pm \#IMM \rightarrow Rd$ Performs addition or subtraction on data in two general registers, or on immediate data and data in a general register. (Immediate byte data cannot be subtracted from byte data in a general register. Use the SUBX or ADD instruction.)
	ADDX SUBX	B	$Rd \pm Rs \pm C \rightarrow Rd$, $Rd \pm \#IMM \pm C \rightarrow Rd$ Performs addition or subtraction with carry or borrow on byte data in two general registers, or on immediate data and data in a general register.
	INC DEC	B/W/L	$Rd \pm 1 \rightarrow Rd$, $Rd \pm 2 \rightarrow Rd$ Increments or decrements a general register by 1 or 2. (Byte operands can be incremented or decremented by 1 only.)
	ADDS SUBS	L	$Rd \pm 1 \rightarrow Rd$, $Rd \pm 2 \rightarrow Rd$, $Rd \pm 4 \rightarrow Rd$ Adds or subtracts the value 1, 2, or 4 to or from data in a 32-bit register.
	DAA DAS	B	Rd decimal adjust $\rightarrow Rd$ Decimal-adjusts an addition or subtraction result in a general register by referring to the CCR to produce 4-bit BCD data.
	MULXU	B/W	$Rd \times Rs \rightarrow Rd$ Performs unsigned multiplication on data in two general registers: either 8 bits \times 8 bits \rightarrow 16 bits or 16 bits \times 16 bits \rightarrow 32 bits.
	MULXS	B/W	$Rd \times Rs \rightarrow Rd$ Performs signed multiplication on data in two general registers: either 8 bits \times 8 bits \rightarrow 16 bits or 16 bits \times 16 bits \rightarrow 32 bits.
	DIVXU	B/W	$Rd \div Rs \rightarrow Rd$ Performs unsigned division on data in two general registers: either 16 bits \div 8 bits \rightarrow 8-bit quotient and 8-bit remainder or 32 bits \div 16 bits \rightarrow 16-bit quotient and 16-bit remainder.

Type	Instruction	Size ^{*1}	Function
Arithmetic operations	DIVXS	B/W	$Rd \div Rs \rightarrow Rd$ Performs signed division on data in two general registers: either 16 bits \div 8 bits \rightarrow 8-bit quotient and 8-bit remainder or 32 bits \div 16 bits \rightarrow 16-bit quotient and 16-bit remainder.
	CMP	B/W/L	$Rd - Rs$, $Rd - \#IMM$ Compares data in a general register with data in another general register or with immediate data, and sets CCR bits according to the result.
	NEG	B/W/L	$0 - Rd \rightarrow Rd$ Takes the two's complement (arithmetic complement) of data in a general register.
	EXTU	W/L	Rd (zero extension) $\rightarrow Rd$ Extends the lower 8 bits of a 16-bit register to word size, or the lower 16 bits of a 32-bit register to longword size, by padding with zeros on the left.
	EXTS	W/L	Rd (sign extension) $\rightarrow Rd$ Extends the lower 8 bits of a 16-bit register to word size, or the lower 16 bits of a 32-bit register to longword size, by extending the sign bit.
	TAS	B	$@ERd - 0, 1 \rightarrow (<bit 7> \text{ of } @Erd)^{*2}$ Tests memory contents, and sets the most significant bit (bit 7) to 1.

Type	Instruction	Size*1	Function
Logic operations	AND	B/W/L	$Rd \wedge Rs \rightarrow Rd$, $Rd \wedge \#IMM \rightarrow Rd$ Performs a logical AND operation on a general register and another general register or immediate data.
	OR	B/W/L	$Rd \vee Rs \rightarrow Rd$, $Rd \vee \#IMM \rightarrow Rd$ Performs a logical OR operation on a general register and another general register or immediate data.
	XOR	B/W/L	$Rd \oplus Rs \rightarrow Rd$, $Rd \oplus \#IMM \rightarrow Rd$ Performs a logical exclusive OR operation on a general register and another general register or immediate data.
	NOT	B/W/L	$\neg (Rd) \rightarrow (Rd)$ Takes the one's complement of general register contents.
Shift operations	SHAL SHAR	B/W/L	$Rd \text{ (shift)} \rightarrow Rd$ Performs an arithmetic shift on general register contents. 1-bit or 2-bit shift is possible.
	SHLL SHLR	B/W/L	$Rd \text{ (shift)} \rightarrow Rd$ Performs a logical shift on general register contents. 1-bit or 2-bit shift is possible.
	ROTL ROTR	B/W/L	$Rd \text{ (rotate)} \rightarrow Rd$ Rotates general register contents. 1-bit or 2-bit rotation is possible.
	ROTXL ROTXR	B/W/L	$Rd \text{ (rotate)} \rightarrow Rd$ Rotates general register contents through the carry flag. 1-bit or 2-bit rotation is possible.

Type	Instruction	Size ^{※1}	Function
Bit-manipulation instructions	BSET	B	$1 \rightarrow (\text{<bit-No.> of <EAd>})$ Sets a specified bit in a general register or memory operand to 1. The bit number is specified by 3-bit immediate data or the lower three bits of a general register.
	BCLR	B	$0 \rightarrow (\text{<bit-No.> of <EAd>})$ Clears a specified bit in a general register or memory operand to 0. The bit number is specified by 3-bit immediate data or the lower three bits of a general register.
	BNOT	B	$\neg (\text{<bit-No.> of <EAd>}) \rightarrow (\text{<bit-No.> of <EAd>})$ Inverts a specified bit in a general register or memory operand. The bit number is specified by 3-bit immediate data or the lower three bits of a general register.
	BTST	B	$\neg (\text{<bit-No.> of <EAd>}) \rightarrow Z$ Tests a specified bit in a general register or memory operand and sets or clears the Z flag accordingly. The bit number is specified by 3-bit immediate data or the lower three bits of a general register.
	BAND	B	$C \wedge (\text{<bit-No.> of <EAd>}) \rightarrow C$ ANDs the carry flag with a specified bit in a general register or memory operand and stores the result in the carry flag.
	BIAND	B	$C \wedge \neg (\text{<bit-No.> of <EAd>}) \rightarrow C$ ANDs the carry flag with the inverse of a specified bit in a general register or memory operand and stores the result in the carry flag. The bit number is specified by 3-bit immediate data.
	BOR	B	$C \vee (\text{<bit-No.> of <EAd>}) \rightarrow C$ ORs the carry flag with a specified bit in a general register or memory operand and stores the result in the carry flag.
	BIOR	B	$C \vee \neg (\text{<bit-No.> of <EAd>}) \rightarrow C$ ORs the carry flag with the inverse of a specified bit in a general register or memory operand and stores the result in the carry flag. The bit number is specified by 3-bit immediate data.

Type	Instruction	Size*1	Function
Bit-manipulation instructions	BXOR	B	$C \oplus (\text{<bit-No.> of <EAd>}) \rightarrow C$ Exclusive-ORs the carry flag with a specified bit in a general register or memory operand and stores the result in the carry flag.
	BIXOR	B	$C \oplus \neg (\text{<bit-No.> of <EAd>}) \rightarrow C$ Exclusive-ORs the carry flag with the inverse of a specified bit in a general register or memory operand and stores the result in the carry flag. The bit number is specified by 3-bit immediate data.
	BLD	B	$(\text{<bit-No.> of <EAd>}) \rightarrow C$ Transfers a specified bit in a general register or memory operand to the carry flag.
	BILD	B	$\neg (\text{<bit-No.> of <EAd>}) \rightarrow C$ Transfers the inverse of a specified bit in a general register or memory operand to the carry flag. The bit number is specified by 3-bit immediate data.
	BST	B	$C \rightarrow (\text{<bit-No.> of <EAd>})$ Transfers the carry flag value to a specified bit in a general register or memory operand.
	BIST	B	$\neg C \rightarrow (\text{<bit-No.> of <EAd>})$ Transfers the inverse of the carry flag value to a specified bit in a general register or memory operand. The bit number is specified by 3-bit immediate data.

Type	Instruction	Size	Function		
Branch instructions	Bcc	—	Branches to a specified relative address if a specified condition is true. The branching conditions are listed below.		
			Mnemonic	Description	Condition
			BRA(BT)	Always (true)	Always
			BRN(BF)	Never (false)	Never
			BHI	High	$C \vee Z = 0$
			BLS	Low or same	$C \vee Z = 1$
			BCC(BHS)	Carry clear (high or same)	$C = 0$
			BCS(BLO)	Carry set (low)	$C = 1$
			BNE	Not equal	$Z = 0$
			BEQ	Equal	$Z = 1$
			BVC	Overflow clear	$V = 0$
			BVS	Overflow set	$V = 1$
			BPL	Plus	$N = 0$
			BMI	Minus	$N = 1$
			BGE	Greater or equal	$N \oplus V = 0$
			BLT	Less than	$N \oplus V = 1$
			BGT	Greater than	$Z \vee (N \oplus V) = 0$
			BLE	Less or equal	$Z \vee (N \oplus V) = 1$
JMP	—	Branches unconditionally to a specified absolute address.			
BSR	—	Branches to a subroutine at a specified relative address.			
JSR	—	Branches to a subroutine at a specified absolute address.			
RTS	—	Returns from a subroutine.			

Type	Instruction	Size*1	Function
System control instructions	TRAPA	—	Starts trap-instruction exception handling.
	RTE	—	Returns from an exception-handling routine.
	SLEEP	—	Causes a transition to a power-down state.
	LDC	B/W	(EAs) → CCR, (EAs) → EXR Moves the source operand contents or immediate data to CCR or EXR. Although CCR and EXR are 8-bit registers, word-size transfers are performed between them and memory. The upper 8 bits are valid.
	STC	B/W	CCR → (EAd), EXR → (EAd) Transfers CCR or EXR contents to a general register or memory. Although CCR and EXR are 8-bit registers, word-size transfers are performed between them and memory. The upper 8 bits are valid.
	ANDC	B	CCR ∧ #IMM → CCR, EXR ∧ #IMM → EXR Logically ANDs the CCR or EXR contents with immediate data.
	ORC	B	CCR ∨ #IMM → CCR, EXR ∨ #IMM → EXR Logically ORs the CCR or EXR contents with immediate data.
	XORC	B	CCR ⊕ #IMM → CCR, EXR ⊕ #IMM → EXR Logically exclusive-ORs the CCR or EXR contents with immediate data.
	NOP	—	PC + 2 → PC Only increments the program counter.

Type	Instruction	Size	Function
Block data transfer instruction	EPMOV.B	—	if R4L \neq 0 then Repeat @ER5+ \rightarrow @ER6+ R4L-1 \rightarrow R4L Until R4L = 0 else next;
	EPMOV.W	—	if R4 \neq 0 then Repeat @ER5+ \rightarrow @ER6+ R4-1 \rightarrow R4 Until R4 = 0 else next; <p>Transfers a data block according to parameters set in general registers R4L or R4, ER5, and ER6.</p> <p>R4L or R4: size of block (bytes) ER5: starting source address ER6: starting destination address</p> <p>Execution of the next instruction begins as soon as the transfer is completed.</p>

Notes: 1. Size refers to the operand size.

B: Byte

W: Word

L: Longword

2. Only register ER0, ER1, ER4, or ER5 should be used when using the TAS instruction.

2.6.4 Basic Instruction Formats

The CPU instructions consist of 2-byte (1-word) units. An instruction consists of an operation field (op field), a register field (r field), an effective address extension (EA field), and a condition field (cc).

Figure 2.9 shows examples of instruction formats.

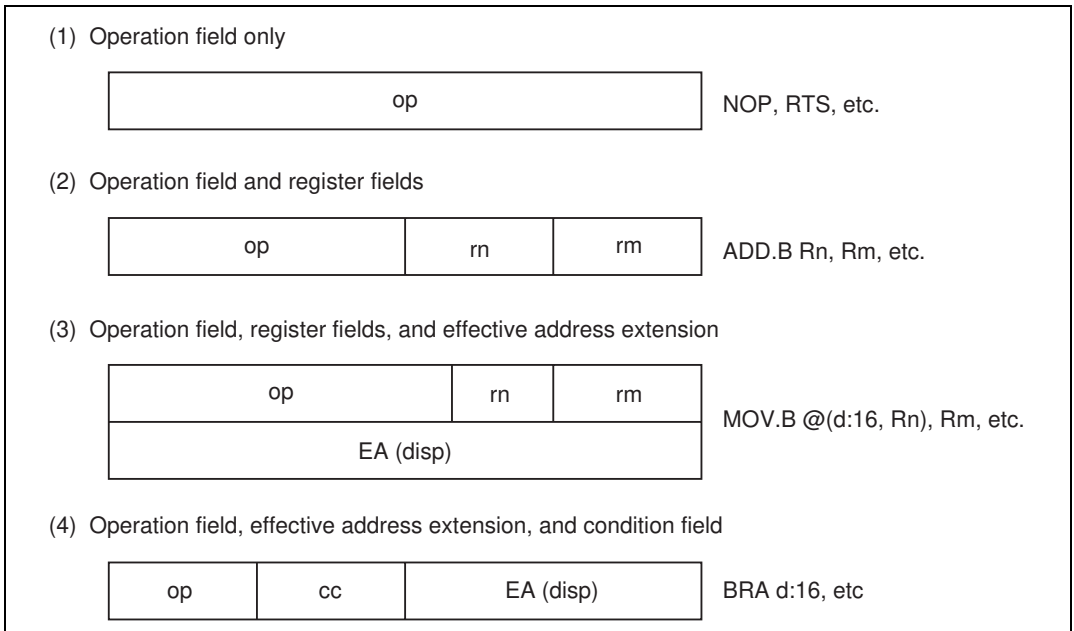

Figure 2.9 Instruction Formats (Examples)

(1) Operation Field: Indicates the function of the instruction, the addressing mode, and the operation to be carried out on the operand. The operation field always includes the first four bits of the instruction. Some instructions have two operation fields.

(2) Register Field: Specifies a general register. Address registers are specified by 3 bits, data registers by 3 bits or 4 bits. Some instructions have two register fields. Some have no register field.

(3) Effective Address Extension: Eight, 16, or 32 bits specifying immediate data, an absolute address, or a displacement.

(4) Condition Field: Specifies the branching condition of Bcc instructions.

2.7 Addressing Modes and Effective Address Calculation

2.7.1 Addressing Mode

The CPU supports the eight addressing modes listed in table 2.4. Each instruction uses a subset of these addressing modes. Arithmetic and logic instructions can use the register direct and immediate modes. Data transfer instructions can use all addressing modes except program-counter relative and memory indirect. Bit manipulation instructions use register direct, register indirect, or absolute addressing mode to specify an operand, and register direct (BSET, BCLR, BNOT, and BTST instructions) or immediate (3-bit) addressing mode to specify a bit number in the operand.

Table 2.4 Addressing Modes

No.	Addressing Mode	Symbol
1	Register direct	Rn
2	Register indirect	@ERn
3	Register indirect with displacement	@(d:16,ERn)/@(d:32,ERn)
4	Register indirect with post-increment Register indirect with pre-decrement	@ERn+ @-ERn
5	Absolute address	@aa:8/@aa:16/@aa:24/@aa:32
6	Immediate	#xx:8/#xx:16/#xx:32
7	Program-counter relative	@(d:8,PC)/@(d:16,PC)
8	Memory indirect	@@aa:8

(1) Register Direct—Rn: The register field of the instruction specifies an 8-, 16-, or 32-bit general register containing the operand. R0H to R7H and R0L to R7L can be specified as 8-bit registers. R0 to R7 and E0 to E7 can be specified as 16-bit registers. ER0 to ER7 can be specified as 32-bit registers.

(2) Register Indirect—@ERn: The register field of the instruction code specifies an address register (ERn) which contains the address of the operand on memory. If the address is a program instruction address, the lower 24 bits are valid and the upper 8 bits are all assumed to be 0 (H'00).

(3) Register Indirect with Displacement—@(d:16, ERn) or @(d:32, ERn): A 16-bit or 32-bit displacement contained in the instruction is added to an address register (ERn) specified by the register field of the instruction, and the sum gives the address of a memory operand. A 16-bit displacement is sign-extended when added.

(4) Register Indirect with Post-Increment or Pre-Decrement—@ERn+ or @-ERn:

- Register indirect with post-increment—@ERn+
The register field of the instruction code specifies an address register (ERn) which contains the address of a memory operand. After the operand is accessed, 1, 2, or 4 is added to the address register contents and the sum is stored in the address register. The value added is 1 for byte access, 2 for word transfer instruction, or 4 for longword transfer instruction. For word or longword transfer instruction, the register value should be even.
- Register indirect with pre-decrement—@-ERn
The value 1, 2, or 4 is subtracted from an address register (ERn) specified by the register field in the instruction code, and the result becomes the address of a memory operand. The result is also stored in the address register. The value subtracted is 1 for byte access, 2 for word transfer instruction, or 4 for longword transfer instruction. For word or longword transfer instruction, the register value should be even.

(5) Absolute Address—@aa:8, @aa:16, @aa:24, or @aa:32: The instruction code contains the absolute address of a memory operand. The absolute address may be 8 bits long (@aa:8), 16 bits long (@aa:16), 24 bits long (@aa:24), or 32 bits long (@aa:32).

To access data, the absolute address should be 8 bits (@aa:8), 16 bits (@aa:16), or 32 bits (@aa:32) long. For an 8-bit absolute address, the upper 24 bits are all assumed to be 1 (H'FFFF). For a 16-bit absolute address the upper 16 bits are a sign extension. A 32-bit absolute address can access the entire address space.

A 24-bit absolute address (@aa:24) indicates the address of a program instruction. The upper 8 bits are all assumed to be 0 (H'00).

Table 2.5 indicates the accessible absolute address ranges.

Table 2.5 Absolute Address Access Ranges

Absolute Address	Advanced Mode	
Data address	8 bits (@aa:8)	H'FFFF00 to H'FFFFFF
	16 bits (@aa:16)	H'000000 to H'007FFF, H'FF8000 to H'FFFFFF
	32 bits (@aa:32)	H'000000 to H'FFFFFF
Program instruction address	24 bits (@aa:24)	

(6) Immediate—#xx:8, #xx:16, or #xx:32: The instruction contains 8-bit (#xx:8), 16-bit (#xx:16), or 32-bit (#xx:32) immediate data as an operand.

The ADDS, SUBS, INC, and DEC instructions contain immediate data implicitly. Some bit manipulation instructions contain 3-bit immediate data in the instruction code, specifying a bit number. The TRAPA instruction contains 2-bit immediate data in its instruction code, specifying a vector address.

(7) Program-Counter Relative—@(d:8, PC) or @(d:16, PC): This mode is used in the Bcc and BSR instructions. An 8-bit or 16-bit displacement contained in the instruction is sign-extended and added to the 24-bit PC contents to generate a branch address. Only the lower 24 bits of this branch address are valid; the upper 8 bits are all assumed to be 0 (H'00). The PC value to which the displacement is added is the address of the first byte of the next instruction, so the possible branching range is -126 to +128 bytes (-63 to +64 words) or -32766 to +32768 bytes (-16383 to +16384 words) from the branch instruction. The resulting value should be an even number.

(8) Memory Indirect—@@aa:8: This mode can be used by the JMP and JSR instructions. The instruction code contains an 8-bit absolute address specifying a memory operand. This memory operand contains a branch address. The upper bits of the absolute address are all assumed to be 0, so the address range is 0 to 255 (H'000000 to H'0000FF).

In advanced mode the memory operand is a longword operand, the first byte of which is assumed to be all 0 (H'00).

Note that the first part of the address range is also the exception vector area. For further details, refer to section 4, Exception Handling.

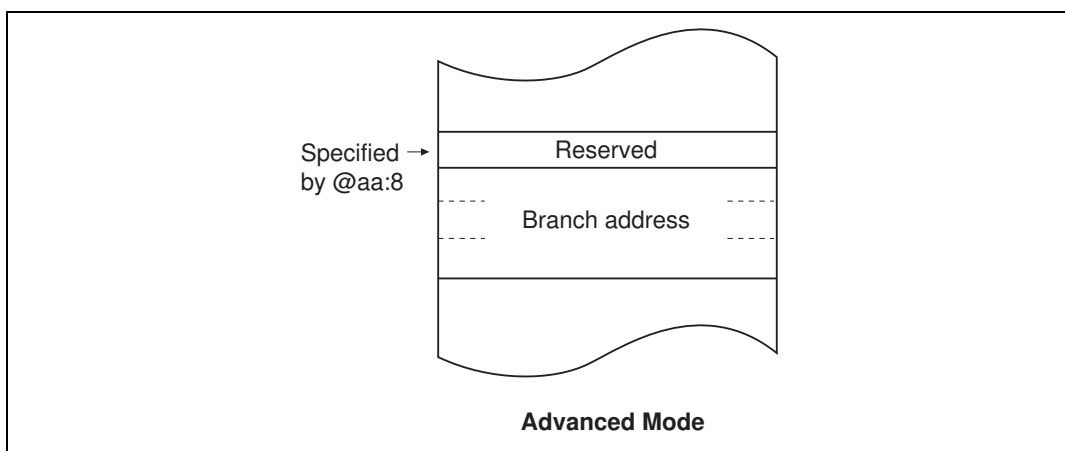

Figure 2.10 Branch Address Specification in Memory Indirect Mode

If an odd address is specified in word or longword memory access, or as a branch address, the least significant bit is regarded as 0, causing data to be accessed or instruction code to be fetched at the address preceding the specified address (For further information, see section 2.5.2, Memory Data Formats).



2.7.2 Effective Address Calculation

Table 2.6 indicates how effective addresses are calculated in each addressing mode.

Table 2.6 Effective Address Calculation

No.	Addressing Mode and Instruction Format	Effective Address Calculation	Effective Address (EA)																													
1	Register direct (Rn) <div style="border: 1px solid black; padding: 2px; display: inline-block; margin: 5px;"> <table border="1" style="border-collapse: collapse;"> <tr> <td style="width: 20px; height: 20px;">op</td> <td style="width: 20px; height: 20px;">rm</td> <td style="width: 20px; height: 20px;">rn</td> </tr> </table> </div>	op	rm	rn		Operand is general register contents.																										
op	rm	rn																														
2	Register indirect (@ERn) <div style="border: 1px solid black; padding: 2px; display: inline-block; margin: 5px;"> <table border="1" style="border-collapse: collapse;"> <tr> <td style="width: 20px; height: 20px;">op</td> <td style="width: 20px; height: 20px;">r</td> </tr> </table> </div>	op	r	<div style="border: 1px solid black; padding: 5px; margin: 5px;"> <table border="1" style="width: 100%; border-collapse: collapse;"> <tr> <td style="width: 30px; height: 20px;">31</td> <td style="width: 70%; height: 20px;">General register contents</td> <td style="width: 30px; height: 20px;">0</td> </tr> </table> </div>	31	General register contents	0	<div style="border: 1px solid black; padding: 5px; margin: 5px;"> <table border="1" style="width: 100%; border-collapse: collapse;"> <tr> <td style="width: 30px; height: 20px;">31</td> <td style="width: 70%; height: 20px;">Don't care</td> <td style="width: 30px; height: 20px;">0</td> </tr> </table> </div>	31	Don't care	0																					
op	r																															
31	General register contents	0																														
31	Don't care	0																														
3	Register indirect with displacement @:d:16, ERn) or @:d:32, ERn) <div style="border: 1px solid black; padding: 2px; display: inline-block; margin: 5px;"> <table border="1" style="border-collapse: collapse;"> <tr> <td style="width: 20px; height: 20px;">op</td> <td style="width: 20px; height: 20px;">r</td> <td style="width: 20px; height: 20px;">disp</td> </tr> </table> </div>	op	r	disp	<div style="border: 1px solid black; padding: 5px; margin: 5px;"> <table border="1" style="width: 100%; border-collapse: collapse;"> <tr> <td style="width: 30px; height: 20px;">31</td> <td style="width: 70%; height: 20px;">General register contents</td> <td style="width: 30px; height: 20px;">0</td> </tr> </table> </div> <div style="border: 1px solid black; padding: 5px; margin: 5px;"> <table border="1" style="width: 100%; border-collapse: collapse;"> <tr> <td style="width: 30px; height: 20px;">31</td> <td style="width: 70%; height: 20px;">Sign extension</td> <td style="width: 30px; height: 20px;">0</td> </tr> </table> </div> <div style="text-align: center; margin: 5px;"> \oplus </div>	31	General register contents	0	31	Sign extension	0	<div style="border: 1px solid black; padding: 5px; margin: 5px;"> <table border="1" style="width: 100%; border-collapse: collapse;"> <tr> <td style="width: 30px; height: 20px;">31</td> <td style="width: 70%; height: 20px;">Don't care</td> <td style="width: 30px; height: 20px;">0</td> </tr> </table> </div>	31	Don't care	0																	
op	r	disp																														
31	General register contents	0																														
31	Sign extension	0																														
31	Don't care	0																														
4	Register indirect with post-increment or pre-decrement · Register indirect with post-increment @ERn+ <div style="border: 1px solid black; padding: 2px; display: inline-block; margin: 5px;"> <table border="1" style="border-collapse: collapse;"> <tr> <td style="width: 20px; height: 20px;">op</td> <td style="width: 20px; height: 20px;">r</td> </tr> </table> </div> · Register indirect with pre-decrement @-ERn <div style="border: 1px solid black; padding: 2px; display: inline-block; margin: 5px;"> <table border="1" style="border-collapse: collapse;"> <tr> <td style="width: 20px; height: 20px;">op</td> <td style="width: 20px; height: 20px;">r</td> </tr> </table> </div>	op	r	op	r	<div style="border: 1px solid black; padding: 5px; margin: 5px;"> <table border="1" style="width: 100%; border-collapse: collapse;"> <tr> <td style="width: 30px; height: 20px;">31</td> <td style="width: 70%; height: 20px;">General register contents</td> <td style="width: 30px; height: 20px;">0</td> </tr> </table> </div> <div style="border: 1px solid black; padding: 5px; margin: 5px;"> <table border="1" style="width: 100%; border-collapse: collapse;"> <tr> <td style="width: 30px; height: 20px;">1, 2, or 4</td> </tr> </table> </div> <div style="text-align: center; margin: 5px;"> \oplus </div> <div style="border: 1px solid black; padding: 5px; margin: 5px;"> <table border="1" style="width: 100%; border-collapse: collapse;"> <tr> <td style="width: 30px; height: 20px;">31</td> <td style="width: 70%; height: 20px;">General register contents</td> <td style="width: 30px; height: 20px;">0</td> </tr> </table> </div> <div style="border: 1px solid black; padding: 5px; margin: 5px;"> <table border="1" style="width: 100%; border-collapse: collapse;"> <tr> <td style="width: 30px; height: 20px;">1, 2, or 4</td> </tr> </table> </div> <div style="text-align: center; margin: 5px;"> \oplus </div> <div style="border: 1px solid black; padding: 5px; margin: 5px;"> <table border="1" style="width: 100%; border-collapse: collapse;"> <tr> <td style="width: 30px; height: 20px;">31</td> <td style="width: 70%; height: 20px;">General register contents</td> <td style="width: 30px; height: 20px;">0</td> </tr> </table> </div> <div style="margin: 5px;"> <table border="1" style="border-collapse: collapse;"> <tr> <td style="width: 30px; height: 20px;">Operand Size</td> <td style="width: 70%; height: 20px;">Value added</td> </tr> <tr> <td style="width: 30px; height: 20px;">Byte</td> <td style="width: 70%; height: 20px;">1</td> </tr> <tr> <td style="width: 30px; height: 20px;">Word</td> <td style="width: 70%; height: 20px;">2</td> </tr> <tr> <td style="width: 30px; height: 20px;">Longword</td> <td style="width: 70%; height: 20px;">4</td> </tr> </table> </div>	31	General register contents	0	1, 2, or 4	31	General register contents	0	1, 2, or 4	31	General register contents	0	Operand Size	Value added	Byte	1	Word	2	Longword	4	<div style="border: 1px solid black; padding: 5px; margin: 5px;"> <table border="1" style="width: 100%; border-collapse: collapse;"> <tr> <td style="width: 30px; height: 20px;">31</td> <td style="width: 70%; height: 20px;">Don't care</td> <td style="width: 30px; height: 20px;">0</td> </tr> </table> </div> <div style="border: 1px solid black; padding: 5px; margin: 5px;"> <table border="1" style="width: 100%; border-collapse: collapse;"> <tr> <td style="width: 30px; height: 20px;">31</td> <td style="width: 70%; height: 20px;">Don't care</td> <td style="width: 30px; height: 20px;">0</td> </tr> </table> </div>	31	Don't care	0	31	Don't care	0
op	r																															
op	r																															
31	General register contents	0																														
1, 2, or 4																																
31	General register contents	0																														
1, 2, or 4																																
31	General register contents	0																														
Operand Size	Value added																															
Byte	1																															
Word	2																															
Longword	4																															
31	Don't care	0																														
31	Don't care	0																														

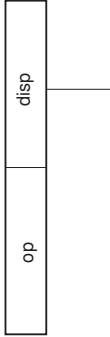
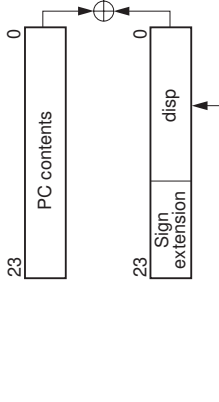
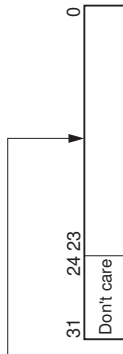
No.	Addressing Mode and Instruction Format	Effective Address Calculation	Effective Address (EA)
5	<p>Absolute address</p> <p>@aa:8</p> <div style="border: 1px solid black; padding: 2px; margin-bottom: 10px;"> op abs </div> <p>@aa:16</p> <div style="border: 1px solid black; padding: 2px; margin-bottom: 10px;"> op abs </div> <p>@aa:24</p> <div style="border: 1px solid black; padding: 2px; margin-bottom: 10px;"> op abs </div> <p>@aa:32</p> <div style="border: 1px solid black; padding: 2px;"> op abs </div>		<div style="margin-bottom: 10px;"> <div style="border: 1px solid black; padding: 2px; display: flex; justify-content: space-between;"> 31 24 23 8 7 0 </div> <div style="border: 1px solid black; padding: 2px; text-align: center;"> Don't care H'FFFF </div> </div> <div style="margin-bottom: 10px;"> <div style="border: 1px solid black; padding: 2px; display: flex; justify-content: space-between;"> 31 24 23 16 15 0 </div> <div style="border: 1px solid black; padding: 2px; text-align: center;"> Don't care Sign extension </div> </div> <div style="margin-bottom: 10px;"> <div style="border: 1px solid black; padding: 2px; display: flex; justify-content: space-between;"> 31 24 23 0 </div> <div style="border: 1px solid black; padding: 2px; text-align: center;"> Don't care </div> </div> <div> <div style="border: 1px solid black; padding: 2px; display: flex; justify-content: space-between;"> 31 24 23 0 </div> <div style="border: 1px solid black; padding: 2px; text-align: center;"> Don't care </div> </div>
6	<p>Immediate #xx:8/#xx:16/#xx:32</p> <div style="border: 1px solid black; padding: 2px; margin-top: 10px;"> op IMM </div>		<p>Operand is immediate data.</p>

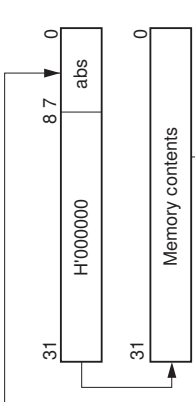
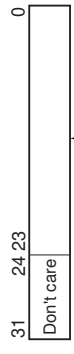
No.	Addressing Mode and Instruction Format	Effective Address Calculation	Effective Address (EA)
7	<p>Program-counter relative @(d:8, PC)/@(d:16, PC)</p> 		
8	<p>Memory indirect @aa:8 · Advanced mode</p> 		

2.8 Processing States

2.8.1 Overview

The CPU has five main processing states: the reset state, exception handling state, program execution state, bus-released state, and power-down state. Figure 2.11 shows a diagram of the processing states. Figure 2.12 indicates the state transitions.

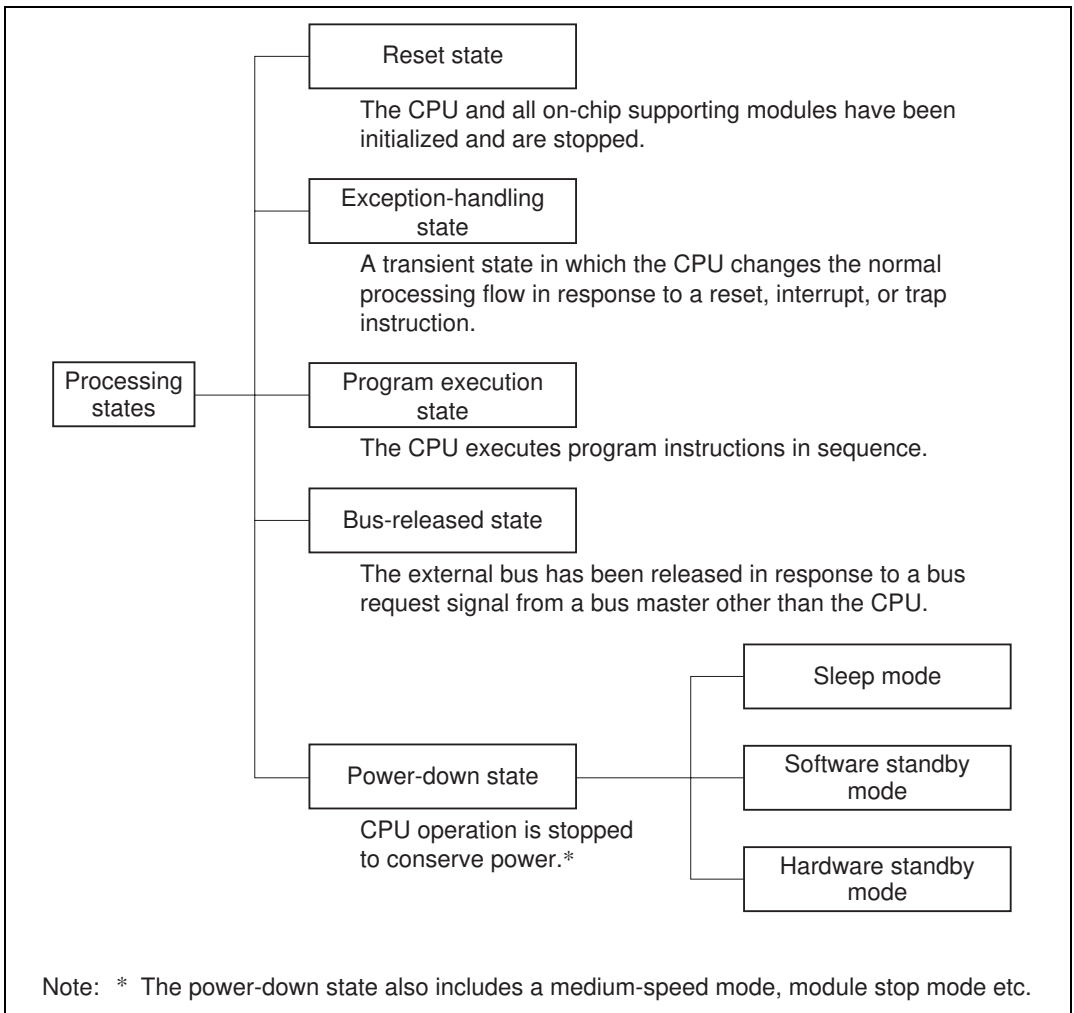

Figure 2.11 Processing States

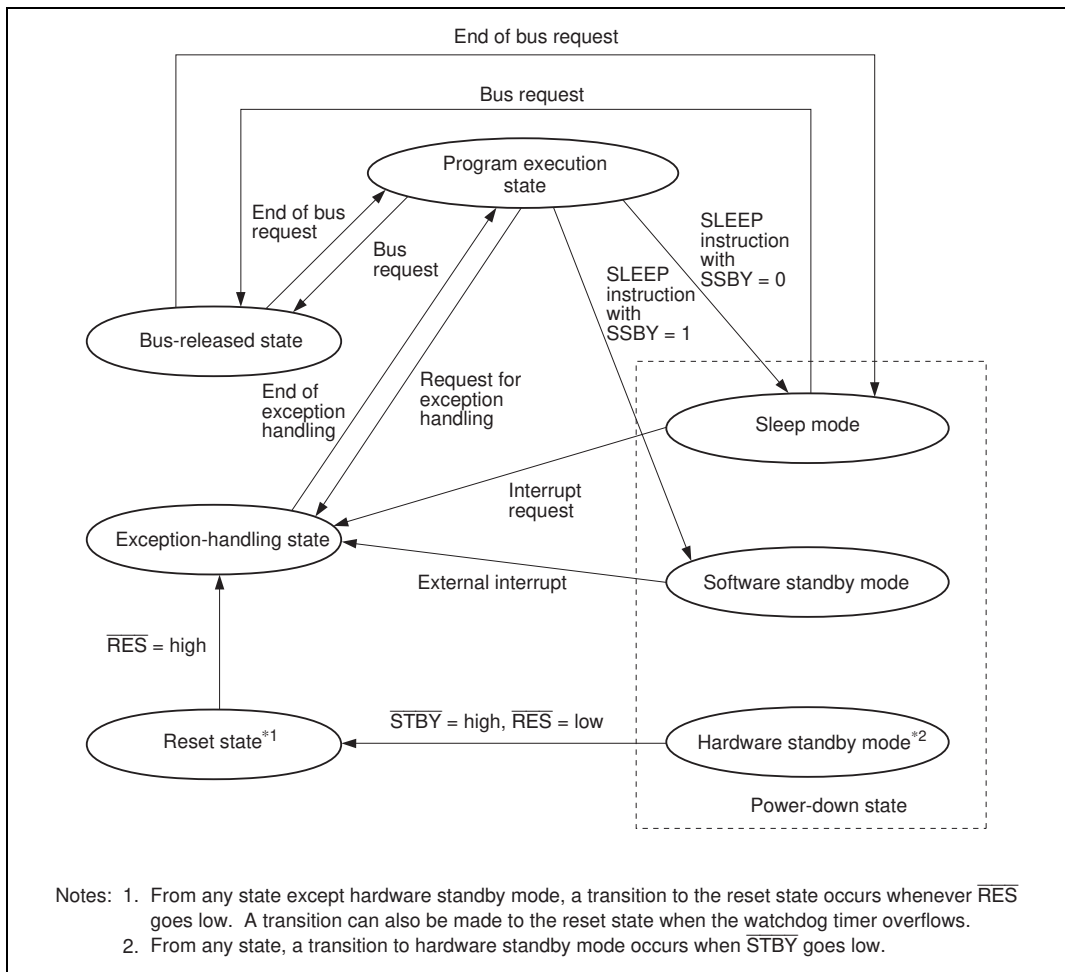

Figure 2.12 State Transitions

2.8.2 Reset State

When the \overline{RES} input goes low all current processing stops and the CPU enters the reset state. All interrupts are masked in the reset state. Reset exception handling starts when the \overline{RES} signal changes from low to high.

The reset state can also be entered by a watchdog timer overflow. For details, refer to section 11, Watchdog Timer.

2.8.3 Exception-Handling State

The exception-handling state is a transient state that occurs when the CPU alters the normal processing flow due to a reset, interrupt, or trap instruction. The CPU fetches a start address (vector) from the exception vector table and branches to that address.

(1) Types of Exception Handling and Their Priority

Exception handling is performed for traces, resets, interrupts, and trap instructions. Table 2.7 indicates the types of exception handling and their priority. Trap instruction exception handling is always accepted, in the program execution state.

Exception handling and the stack structure depend on the interrupt control mode set in SYSCR.

Table 2.7 Exception Handling Types and Priority

Priority	Type of Exception	Detection Timing	Start of Exception Handling
High  Low	Reset	Synchronized with clock	Exception handling starts immediately after a low-to-high transition at the $\overline{\text{RES}}$ pin, or when the watchdog timer overflows.
	Trace	End of instruction execution or end of exception-handling sequence* ¹	When the trace (T) bit is set to 1, the trace starts at the end of the current instruction or current exception-handling sequence.
	Interrupt	End of instruction execution or end of exception-handling sequence* ²	When an interrupt is requested, exception handling starts at the end of the current instruction or current exception-handling sequence.
	Trap instruction	When TRAPA instruction is executed	Exception handling starts when a trap (TRAPA) instruction is executed* ³ .

- Notes: 1. Traces are enabled only in interrupt control mode 2. Trace exception-handling is not executed at the end of the RTE instruction.
 2. Interrupts are not detected at the end of the ANDC, ORC, XORC, and LDC instructions, or immediately after reset exception handling.
 3. Trap instruction exception handling is always accepted, in the program execution state.

(2) Reset Exception Handling

After the $\overline{\text{RES}}$ pin has gone low and the reset state has been entered, when $\overline{\text{RES}}$ goes high again, reset exception handling starts. When reset exception handling starts the CPU fetches a start address (vector) from the exception vector table and starts program execution from that address. All interrupts, including NMI, are disabled during reset exception handling and after it ends.

(3) Traces

Traces are enabled only in interrupt control mode 2. Trace mode is entered when the T bit of EXR is set to 1. When trace mode is established, trace exception handling starts at the end of each instruction.

At the end of a trace exception-handling sequence, the T bit of EXR is cleared to 0 and trace mode is cleared. Interrupt masks are not affected.

The T bit saved on the stack retains its value of 1, and when the RTE instruction is executed to return from the trace exception-handling routine, trace mode is entered again. Trace exception-handling is not executed at the end of the RTE instruction.

Trace mode is not entered in interrupt control mode 0, regardless of the state of the T bit.

(4) Interrupt Exception Handling and Trap Instruction Exception Handling

When interrupt or trap-instruction exception handling begins, the CPU references the stack pointer (ER7) and pushes the program counter and other control registers onto the stack. Next, the CPU alters the settings of the interrupt mask bits in the control registers. Then the CPU fetches a start address (vector) from the exception vector table and program execution starts from that start address.

Figure 2.13 shows the stack after exception handling ends.

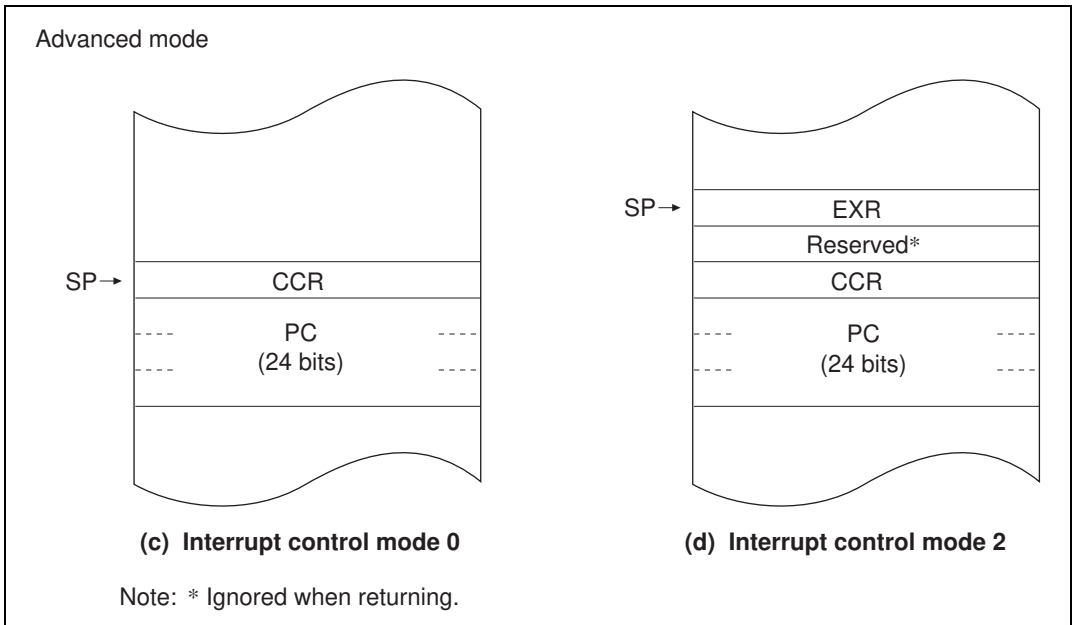

Figure 2.13 Stack Structure after Exception Handling (Examples)

2.8.4 Program Execution State

In this state the CPU executes program instructions in sequence.

2.8.5 Bus-Released State

This is a state in which the bus has been released in response to a bus request from a bus master other than the CPU. While the bus is released, the CPU halts.

There is one other bus master in addition to the CPU: the data transfer controller (DTC).

For further details, refer to section 6, Bus Controller.

2.8.6 Power-Down State

The power-down state includes both modes in which the CPU stops operating and modes in which the CPU does not stop. There are three modes in which the CPU stops operating: sleep mode, software standby mode, and hardware standby mode. There are also two other power-down modes: medium-speed mode, and module stop mode. In medium-speed mode the CPU and other

bus masters operate on a medium-speed clock. Module stop mode permits halting of the operation of individual modules, other than the CPU. For details, refer to section 19, Power-Down Modes.

(1) Sleep Mode: A transition to sleep mode is made if the SLEEP instruction is executed while the software standby bit (SSBY) in the standby control register (SBYCR) is cleared to 0. In sleep mode, CPU operations stop immediately after execution of the SLEEP instruction. The contents of CPU registers are retained.

(2) Software Standby Mode: A transition to software standby mode is made if the SLEEP instruction is executed while the SSBY bit in SBYCR is set to 1. In software standby mode, the CPU and clock halt and all MCU operations stop. As long as a specified voltage is supplied, the contents of CPU registers and on-chip RAM are retained. The I/O ports also remain in their existing states.

(3) Hardware Standby Mode: A transition to hardware standby mode is made when the $\overline{\text{STBY}}$ pin goes low. In hardware standby mode, the CPU and clock halt and all MCU operations stop. The on-chip supporting modules are reset, but as long as a specified voltage is supplied, on-chip RAM contents are retained.

2.9 Basic Timing

2.9.1 Overview

The CPU is driven by a system clock, denoted by the symbol ϕ . The period from one rising edge of ϕ to the next is referred to as a "state." The memory cycle or bus cycle consists of one, two, or three states. Different methods are used to access on-chip memory, on-chip supporting modules, and the external address space.

2.9.2 On-Chip Memory (ROM, RAM)

On-chip memory is accessed in one state. The data bus is 16 bits wide, permitting both byte and word transfer instruction. Figure 2.14 shows the on-chip memory access cycle. Figure 2.15 shows the pin states.

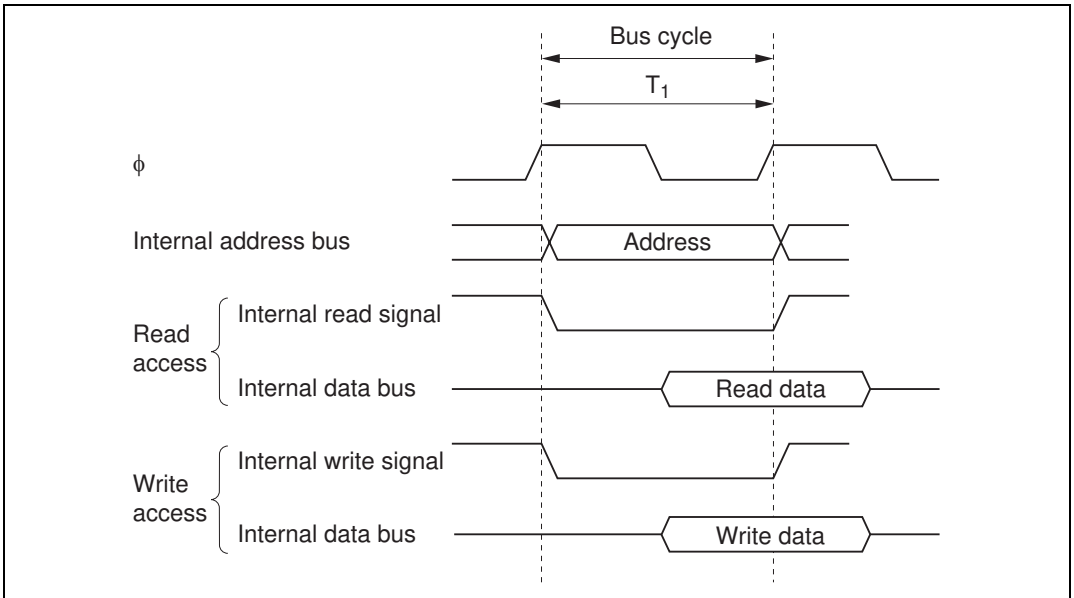

Figure 2.14 On-Chip Memory Access Cycle

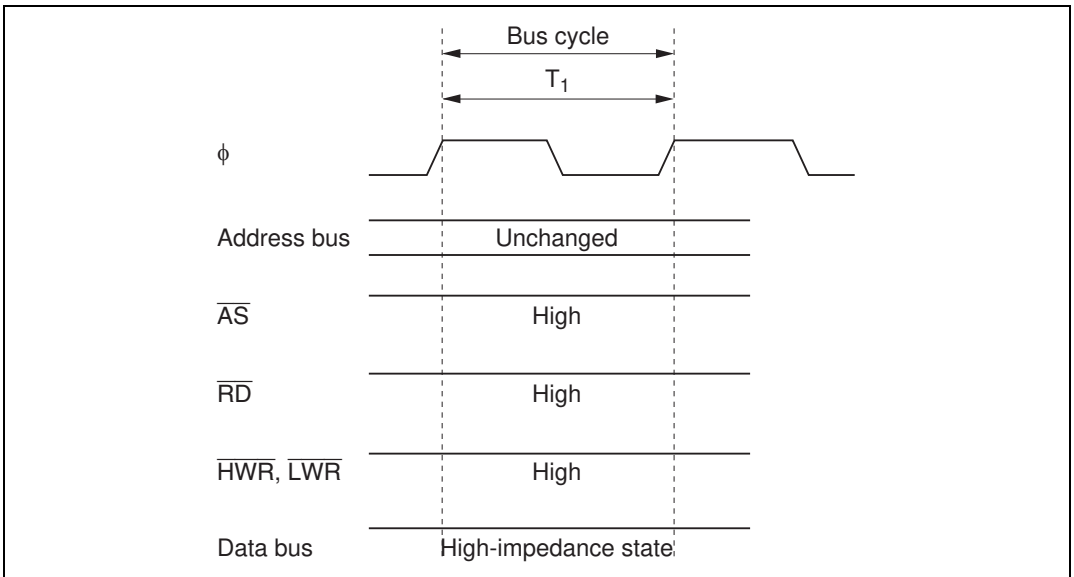

Figure 2.15 Pin States during On-Chip Memory Access

2.9.3 On-Chip Supporting Module Access Timing

The on-chip supporting modules are accessed in two states. The data bus is either 8 bits or 16 bits wide, depending on the particular internal I/O register being accessed. Figure 2.16 shows the access timing for the on-chip supporting modules. Figure 2.17 shows the pin states.

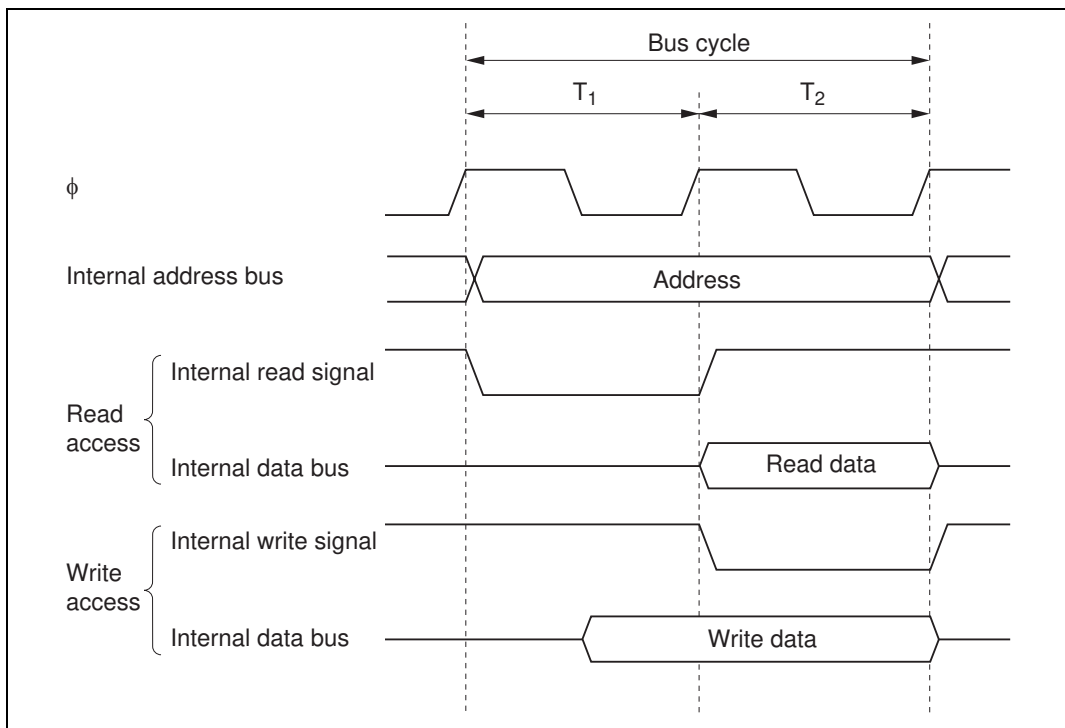

Figure 2.16 On-Chip Supporting Module Access Cycle

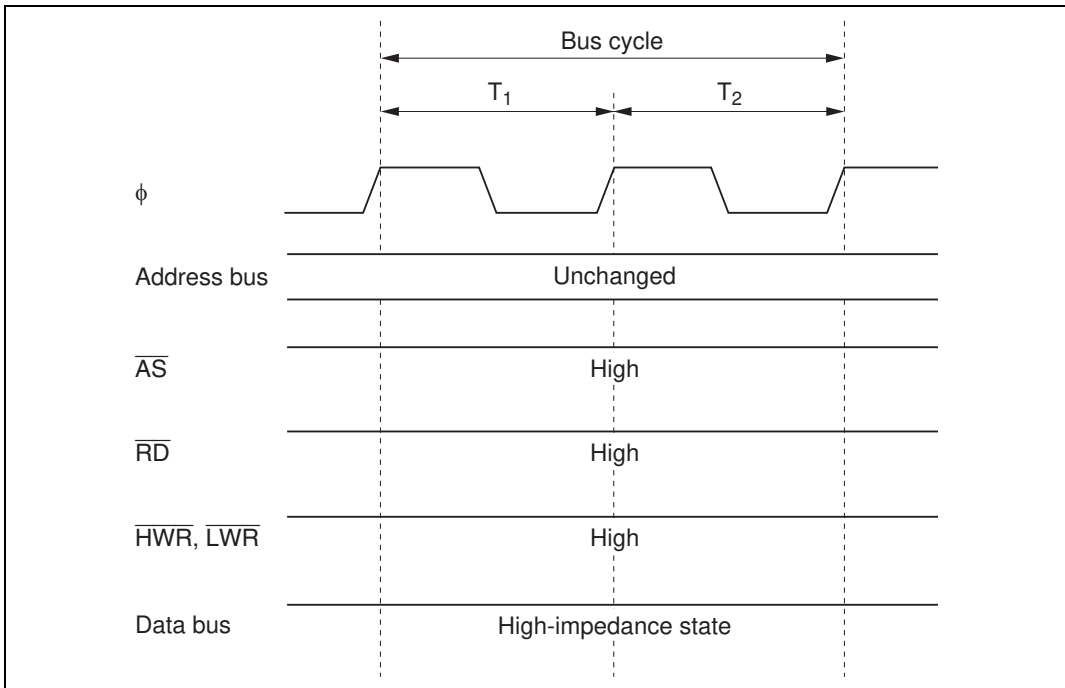

Figure 2.17 Pin States during On-Chip Supporting Module Access

2.9.4 External Address Space Access Timing

The external address space is accessed with an 8-bit or 16-bit data bus width in a two-state or three-state bus cycle. In three-state access, wait states can be inserted. For further details, refer to section 6, Bus Controller.

2.10 Usage Note

2.10.1 TAS Instruction

Only register ER0, ER1, ER4, or ER5 should be used when using the TAS instruction. The TAS instruction is not generated by the Renesas H8S and H8/300 Series C/C++ compilers. If the TAS instruction is used as a user-defined intrinsic function, ensure that only register ER0, ER1, ER4, or ER5 is used.

Section 3 MCU Operating Modes

3.1 Overview

3.1.1 Operating Mode Selection (H8S/2318 F-ZTAT, H8S/2317 F-ZTAT, H8S/2315 F-ZTAT, and H8S/2314 F-ZTAT)

The H8S/2318 F-ZTAT, H8S/2317 F-ZTAT, H8S/2315 F-ZTAT, and H8S/2314 F-ZTAT have eight operating modes (modes 4 to 7, 10, 11, 14 and 15). These modes are determined by the mode pin (MD2 to MD0) and flash write enable pin (FWE) settings. The CPU operating mode and initial bus width can be selected as shown in table 3.1.

Table 3.1 lists the MCU operating modes.

Table 3.1 MCU Operating Mode Selection (H8S/2318 F-ZTAT, H8S/2317 F-ZTAT, H8S/2315 F-ZTAT, and H8S/2314 F-ZTAT)

MCU Operating Mode	FWE	MD2	MD1	MD0	CPU Operating Mode	Description	On-Chip ROM	External Data Bus	
								Initial Value	Max. Value
1*	0	0	0	1	—	—	—	—	—
2*			1	0					
3*				1					
4		1	0	0	Advanced	Expanded mode with on-chip ROM disabled	Disabled	16 bits	16 bits
5				1				8 bits	16 bits
6			1	0		Expanded mode with on-chip ROM enabled	Enabled	8 bits	16 bits
7				1		Single-chip mode		—	—
8*	1	0	0	0	—	—	—	—	—
9*				1					
10			1	0	Advanced	Boot mode	Enabled	8 bits	16 bits
11				1				—	—
12*		1	0	0	—	—	—	—	—
13*				1					
14			1	0	Advanced	User program mode	Enabled	8 bits	16 bits
15				1				—	—

Note: * Cannot be used in this LSI.

The CPU's architecture allows for 4 Gbytes of address space, but the H8S/2318 F-ZTAT, H8S/2317 F-ZTAT, H8S/2315 F-ZTAT, and H8S/2314 F-ZTAT actually access a maximum of 16 Mbytes.

Modes 4 to 6 are externally expanded modes that allow access to external memory and peripheral devices.

The external expansion modes allow switching between 8-bit and 16-bit bus modes. After program execution starts, an 8-bit or 16-bit address space can be set for each area, depending on the bus controller setting. If 16-bit access is selected for any one area, 16-bit bus mode is set; if 8-bit access is selected for all areas, 8-bit bus mode is set. Note that the functions of each pin depend on the operating mode.

Modes 10, 11, 14, and 15 are boot modes and user program modes in which the flash memory can be programmed and erased. For details, see section 17, ROM.

The H8S/2318 F-ZTAT, H8S/2317 F-ZTAT, H8S/2315 F-ZTAT, and H8S/2314 F-ZTAT can only be used in modes 4 to 7, 10, 11, 14, and 15. This means that the flash write enable pin and mode pins must be set to select one of these modes.

Do not change the inputs at the mode pins during operation.

3.1.2 Operating Mode Selection (Mask ROM, ROMless, H8S/2319 F-ZTAT, and H8S/2319C F-ZTAT)

The ROMless and mask ROM versions have four operating modes (modes 4 to 7). The H8S/2319 F-ZTAT has six operating modes (modes 2 to 7). The H8S/2319C F-ZTAT has seven operating mode (modes 1 to 7). The operating mode is determined by the mode pins (MD2 to MD0). The CPU operating mode, enabling or disabling of on-chip ROM, and the initial bus width setting can be selected as shown in table 3.2.

Table 3.2 lists the MCU operating modes.

Table 3.2 MCU Operating Mode Selection (Mask ROM, ROMless versions, H8S/2319 F-ZTAT, and H8S/2319C F-ZTAT)

MCU Operating Mode	MD2	MD1	MD0	CPU Operating Mode	Description	On-Chip ROM	External Data Bus	
							Initial Value	Max. Value
1* ¹	0	0	1	—	—	—	—	—
2* ²		1	0					
3* ²			1					
4* ³	1	0	0	Advanced	Expanded mode with on-chip ROM disabled	Disabled	16 bits	16 bits
5* ³			1				8 bits	16 bits
6		1	0		Expanded mode with on-chip ROM enabled	Enabled	8 bits	16 bits
7			1		Single-chip mode		—	—

- Notes: 1. User boot mode in the H8S/2319C F-ZTAT. For user boot mode in the H8S/2319C F-ZTAT, see table 17.52.
2. Boot mode in the H8S/2319 F-ZTAT and H8S/2319C F-ZTAT.
For boot mode in the H8S/2319 F-ZTAT, see table 17.30. Also see table 17.30, for information on user program mode.
For boot mode in the H8S/2319C F-ZTAT, see table 17.52. Also see table 17.52, for information on user program mode.
3. Only modes 4 and 5 are provided in the ROMless versions.

The CPU's architecture allows for 4 Gbytes of address space, but the Mask ROM, ROMless version, H8S/2319 F-ZTAT, and H8S/2319C F-ZTAT actually access a maximum of 16 Mbytes.

Modes 4 to 6 are externally expanded modes that allow access to external memory and peripheral devices.

The external expansion modes allow switching between 8-bit and 16-bit bus modes. After program execution starts, an 8-bit or 16-bit address space can be set for each area, depending on the bus controller setting. If 16-bit access is selected for any one area, 16-bit bus mode is set; if 8-bit access is selected for all areas, 8-bit bus mode is set. Note that the functions of each pin depend on the operating mode.

The ROMless and mask ROM versions can only be used in modes 4 to 7. This means that the mode pins must be set to select one of these modes. However, note that only mode 4 or 5 can be set for the ROMless versions. The H8S/2319 F-ZTAT can only be used in modes 2 to 7. This means that the mode pins must be set to select one of these modes. The H8S/2319C F-ZTAT can

only be used in modes 1 to 7. This means that the mode pins must be set to select one of these modes.

Do not change the inputs at the mode pins during operation.

3.1.3 Register Configuration

The H8S/2319 Group has a mode control register (MDCR) that indicates the inputs at the mode pins (MD2 to MD0), and a system control register (SYSCR) and system control register 2 (SYSCR2)*² that control the operation of the chip. Table 3.3 summarizes these registers.

Table 3.3 Registers

Name	Abbreviation	R/W	Initial Value	Address* ¹
Mode control register	MDCR	R	Undefined	H'FF3B
System control register	SYSCR	R/W	H'01	H'FF39
System control register 2* ²	SYSCR2	R/W	H'00	H'FF42

Notes: 1. Lower 16 bits of the address.

2. The SYSCR2 register can only be used in the F-ZTAT versions. In the mask ROM and ROMless versions this register will return an undefined value if read, and cannot be modified.

3.2 Register Descriptions

3.2.1 Mode Control Register (MDCR)

Bit	:	7	6	5	4	3	2	1	0
		—	—	—	—	—	MDS2	MDS1	MDS0
Initial value	:	1	0	0	0	0	—*	—*	—*
R/W	:	—	—	—	—	—	R	R	R

Note: * Determined by pins MD2 to MD0.

MDCR is an 8-bit read-only register that indicates the current operating mode of the H8S/2319 Group chip.

Bit 7—Reserved: This bit is always read as 1, and cannot be modified.

Bits 6 to 3—Reserved: These bits are always read as 0, and cannot be modified.

Bits 2 to 0—Mode Select 2 to 0 (MDS2 to MDS0): These bits indicate the input levels at pins MD2 to MD0 (the current operating mode). Bits MDS2 to MDS0 correspond to pins MD2 to MD0. MDS2 to MDS0 are read-only bits, and cannot be written to. The mode pin (MD2 to MD0) input levels are latched into these bits when MDCR is read. These latches are canceled by a reset.

3.2.2 System Control Register (SYSCR)

Bit	:	7	6	5	4	3	2	1	0
		—	—	INTM1	INTM0	NMIEG	LWROD	—	RAME
Initial value :		0	0	0	0	0	0	0	1
R/W	:	R/W	—	R/W	R/W	R/W	R/W	R/W	R/W

Bit 7—Reserved: Only 0 should be written to this bit.

Bit 6—Reserved: This bit is always read as 0, and cannot be modified.

Bits 5 and 4—Interrupt Control Mode 1 and 0 (INTM1, INTM0): These bits select the control mode of the interrupt controller. For details of the interrupt control modes, see section 5.4.1, Interrupt Control Modes and Interrupt Operation.

Bit 5 INTM1	Bit 4 INTM0	Interrupt Control Mode	Description
0	0	0	Control of interrupts by I bit (Initial value)
	1	—	Setting prohibited
1	0	2	Control of interrupts by I2 to I0 bits and IPR
	1	—	Setting prohibited

Bit 3—NMI Edge Select (NMIEG): Selects the valid edge of the NMI interrupt input.

Bit 3 NMIEG	Description
0	An interrupt is requested at the falling edge of NMI input (Initial value)
1	An interrupt is requested at the rising edge of NMI input

Bit 2—LWR Output Disable (LWROD): Enables or disables $\overline{\text{LWR}}$ output.

Bit 2

LWROD	Description	
0	PF3 is designated as $\overline{\text{LWR}}$ output pin	(Initial value)
1	PF3 is designated as I/O port, and does not function as $\overline{\text{LWR}}$ output pin	

Bit 1—Reserved: Only 0 should be written to this bit.

Bit 0—RAM Enable (RAME): Enables or disables the on-chip RAM. The RAME bit is initialized when the reset state is released. It is not initialized in software standby mode.

Bit 0

RAME	Description	
0	On-chip RAM is disabled	
1	On-chip RAM is enabled	(Initial value)

3.2.3 System Control Register 2 (SYSCR2) (F-ZTAT Versions Only)

Bit	7	6	5	4	3	2	1	0
	—	—	—	—	FLSHE	—	—	—
Initial value :	0	0	0	0	0	0	0	0
R/W :	—	—	—	—	R/W	—	—	— (R/W)*

Note: * R/W in the H8S/2319 F-ZTAT.

SYSCR2 is an 8-bit readable/writable register that performs on-chip flash memory control.

SYSCR2 is initialized to H'00 by a reset, and in hardware standby mode.

Bits 7 to 4—Reserved: These bits are always read as 0, and cannot be modified.

Bit 3—Flash Memory Control Register Enable (FLSHE): Controls CPU access to the flash memory control registers (FLMCR1, FLMCR2, EBR1, and EBR2 in the case of the H8S/2319 F-ZTAT, H8S/2318 F-ZTAT, H8S/2317 F-ZTAT, H8S/2315 F-ZTAT, and H8S/2314 F-ZTAT; FCCS, FPCS, FECS, FKEY, FMATS, FTDAR, FVARC, FVADRR, FVADRE, FVADRH, and FVADRL in the case of the H8S/2319C F-ZTAT). For details, see section 17, ROM.

Bit 3

FLSHE	Description
0	H8S/2319 F-ZTAT, H8S/2318 F-ZTAT, H8S/2317 F-ZTAT, H8S/2315 F-ZTAT, and H8S/2314 F-ZTAT <ul style="list-style-type: none"> Flash control registers are not selected for addresses H'FFFFC8 to H'FFFFCB (Initial value) H8S/2319C F-ZTAT <ul style="list-style-type: none"> Flash control registers are not selected for addresses H'FFFFC4 to H'FFFFCF
1	H8S/2319 F-ZTAT, H8S/2318 F-ZTAT, H8S/2317 F-ZTAT, H8S/2315 F-ZTAT, and H8S/2314 F-ZTAT <ul style="list-style-type: none"> Flash control registers are selected for addresses H'FFFFC8 to H'FFFFCB H8S/2319C F-ZTAT <ul style="list-style-type: none"> Flash control registers are selected for addresses H'FFFFC4 to H'FFFFCF

Bits 2 and 1—Reserved: These bits are always read as 0, and cannot be modified.

Bit 0—Reserved: In the H8S/2318 F-ZTAT, H8S/2317 F-ZTAT, H8S/2315 F-ZTAT, and H8S/2314 F-ZTAT, this bit is always read as 0 and cannot be modified.

In the H8S/2319 F-ZTAT or H8S/2319C F-ZTAT, this bit is reserved and should only be written with 0.

3.3 Operating Mode Descriptions

3.3.1 Mode 1 (H8S/2319C F-ZTAT Only)

This is a flash memory boot mode. See section 17, ROM, for details.

Except for the fact that flash memory programming and erasing can be performed, operation in this mode is the same as in advanced single-chip mode.

3.3.2 Mode 2 (H8S/2319 F-ZTAT and H8S/2319C F-ZTAT Only)

This is a flash memory boot mode. See section 17, ROM, for details.

Except for the fact that flash memory programming and erasing can be performed, operation in this mode is the same as in advanced expanded mode with on-chip ROM enabled.

3.3.3 Mode 3 (H8S/2319 F-ZTAT and H8S/2319C F-ZTAT Only)

This is a flash memory boot mode. See section 17, ROM, for details.

Except for the fact that flash memory programming and erasing can be performed, operation in this mode is the same as in advanced single chip mode.

3.3.4 Mode 4 (Expanded Mode with On-Chip ROM Disabled)

The CPU can access a 16-Mbyte address space in advanced mode. The on-chip ROM is disabled.

Pins P13 to P10, ports A, B, and C function as an address bus, ports D and E functions as a data bus, and part of port F carries bus control signals.

Pins P13 to P10 function as input ports immediately after a reset. These pins can be set to output addresses by setting the corresponding data direction register (DDR) bits and A23E to A20E in PFCR1 to 1.

The initial bus mode after a reset is 16 bits, with 16-bit access to all areas. However, note that if 8-bit access is designated by the bus controller for all areas, the bus mode switches to 8 bits.

3.3.5 Mode 5 (Expanded Mode with On-Chip ROM Disabled)

The CPU can access a 16-Mbyte address space in advanced mode. The on-chip ROM is disabled.

Pins P13 to P10, ports A, B, and C function as an address bus, port D functions as a data bus, and part of port F carries bus control signals.

Pins P13 to P10 function as input ports immediately after a reset. These pins can be set to output addresses by setting the corresponding data direction register (DDR) bits and A23E to A20E in PFCR1 to 1.

The initial bus mode after a reset is 8 bits, with 8-bit access to all areas. However, note that if at least one area is designated for 16-bit access by the bus controller, the bus mode switches to 16 bits and port E becomes a data bus.

3.3.6 Mode 6 (Expanded Mode with On-Chip ROM Enabled)

The CPU can access a 16-Mbyte address space in advanced mode. The on-chip ROM is enabled.

Pins P13 to P10, ports A, B, and C function as input ports immediately after a reset. These pins can be set to output addresses by setting the corresponding data direction register (DDR) bits and A23E to A20E in PFCR1 to 1. Port D functions as a data bus, and part of port F carries bus control signals.

The initial bus mode after a reset is 8 bits, with 8-bit access to all areas. However, note that if at least one area is designated for 16-bit access by the bus controller, the bus mode switches to 16 bits and port E becomes a data bus.

3.3.7 Mode 7 (Single-Chip Mode)

The CPU can access a 16-Mbyte address space in advanced mode. The on-chip ROM is enabled, but external addresses cannot be accessed.

All I/O ports are available for use as input/output ports.

3.3.8 Modes 8 and 9

Modes 8 and 9 are not supported in the H8S/2319 Group, and must not be set.

3.3.9 Mode 10 (H8S/2318 F-ZTAT, H8S/2317 F-ZTAT, H8S/2315 F-ZTAT, and H8S/2314 F-ZTAT Only)

This is a flash memory boot mode. For details, see section 17, ROM.

Except for the fact that flash memory programming and erasing can be performed, operation in this mode is the same as in advanced expanded mode with on-chip ROM enabled.

3.3.10 Mode 11 (H8S/2318 F-ZTAT, H8S/2317 F-ZTAT, H8S/2315 F-ZTAT, and H8S/2314 F-ZTAT Only)

This is a flash memory boot mode. For details, see section 17, ROM.

Except for the fact that flash memory programming and erasing can be performed, operation in this mode is the same as in advanced single-chip mode.

3.3.11 Modes 12 and 13

Modes 12 and 13 are not supported in the H8S/2319 Group, and must not be set.

3.3.12 Mode 14 (H8S/2318 F-ZTAT, H8S/2317 F-ZTAT, H8S/2315 F-ZTAT, and H8S/2314 F-ZTAT Only)

This is a flash memory user program mode. For details, see section 17, ROM.

Except for the fact that flash memory programming and erasing can be performed, operation in this mode is the same as in advanced expanded mode with on-chip ROM enabled.

3.3.13 Mode 15 (H8S/2318 F-ZTAT, H8S/2317 F-ZTAT, H8S/2315 F-ZTAT, and H8S/2314 F-ZTAT Only)

This is a flash memory user program mode. For details, see section 17, ROM.

Except for the fact that flash memory programming and erasing can be performed, operation in this mode is the same as in advanced single-chip mode.

3.4 Pin Functions in Each Operating Mode

The pin functions of ports 1 and A to F vary depending on the operating mode. Table 3.4 shows their functions in each operating mode.

Table 3.4 Pin Functions in Each Mode

Port		Mode 4	Mode 5	Mode 2 ^{*4}	Mode 1 ^{*5}
				Mode 6 ^{*2}	Mode 3 ^{*4}
				Mode 10 ^{*3}	Mode 7 ^{*2}
				Mode 14 ^{*3}	Mode 11 ^{*3}
					Mode 15 ^{*3}
Port 1	P13 to P10	P ^{*1} /T/A	P ^{*1} /T/A	P ^{*1} /T/A	P ^{*1} /T
Port A	PA3 to PA0	A	A	P ^{*1} /A	P
Port B		A	A	P ^{*1} /A	P
Port C		A	A	P ^{*1} /A	P
Port D		D	D	D	P
Port E		P/D ^{*1}	P ^{*1} /D	P ^{*1} /D	P
Port F	PF7	P/C ^{*1}	P/C ^{*1}	P/C ^{*1}	P ^{*1} /C
	PF6, PF3	P/C ^{*1}	P/C ^{*1}	P/C ^{*1}	P
	PF5, PF4	C	C	C	
	PF2 to PF0	P ^{*1} /C	P ^{*1} /C	P ^{*1} /C	

Legend:

P: I/O port

T: Timer I/O

A: Address bus output

D: Data bus I/O

C: Control signals, clock I/O

Notes: 1. After reset

2. Not used on ROMless versions.

3. Applies to H8S/2318 F-ZTAT, H8S/2317 F-ZTAT, H8S/2315 F-ZTAT, and H8S/2314 F-ZTAT only.

4. Applies to H8S/2319 F-ZTAT and H8S/2319C F-ZTAT only.

5. Applies to H8S/2319C F-ZTAT only.

3.5 Memory Map in Each Operating Mode

Figures 3.1 to 3.9 show memory maps for each of the operating modes.

The address space is 16 Mbytes.

The address space is divided into eight areas.

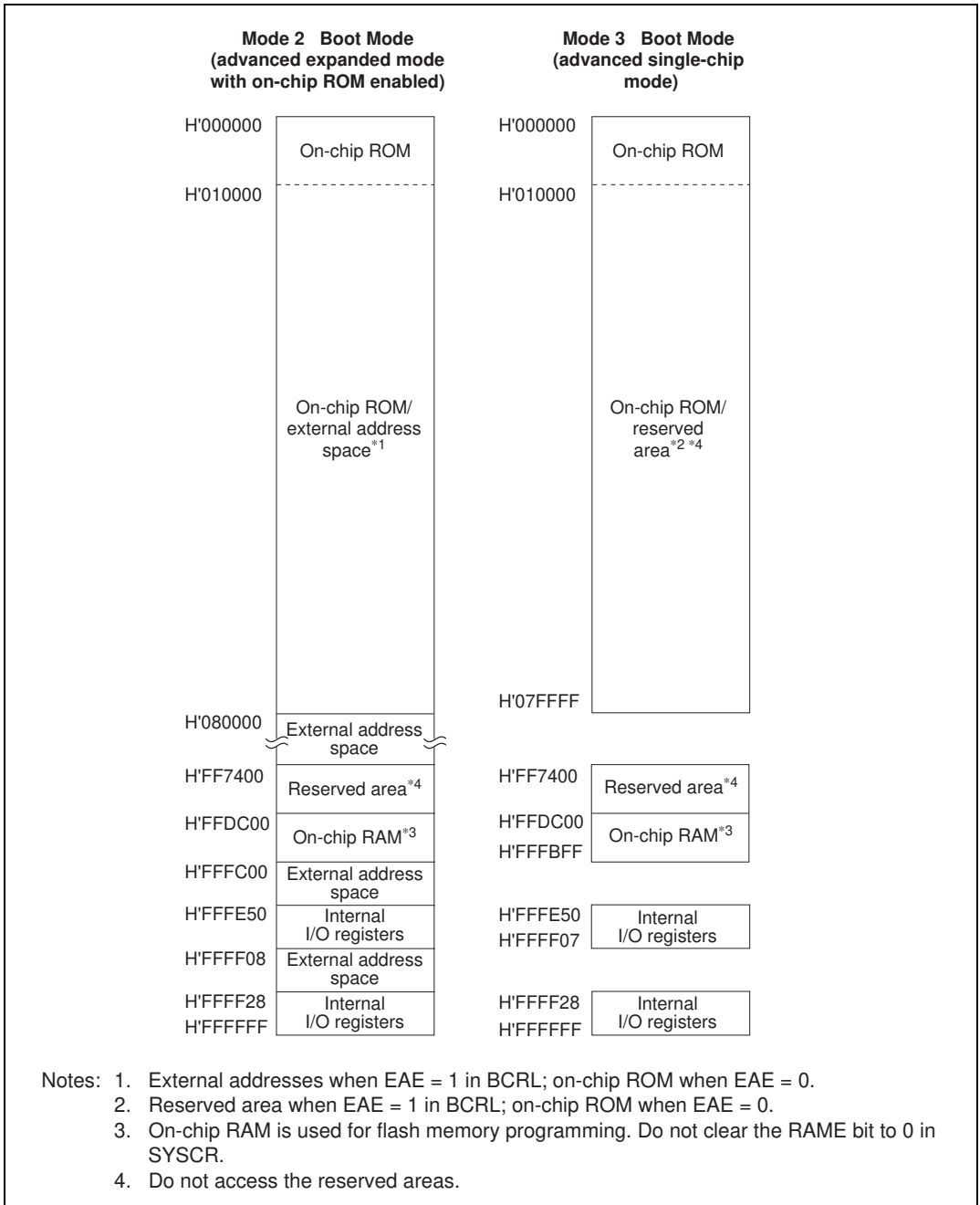

**Figure 3.1 (a) H8S/2319 Memory Map in Each Operating Mode
(F-ZTAT Version Only)**

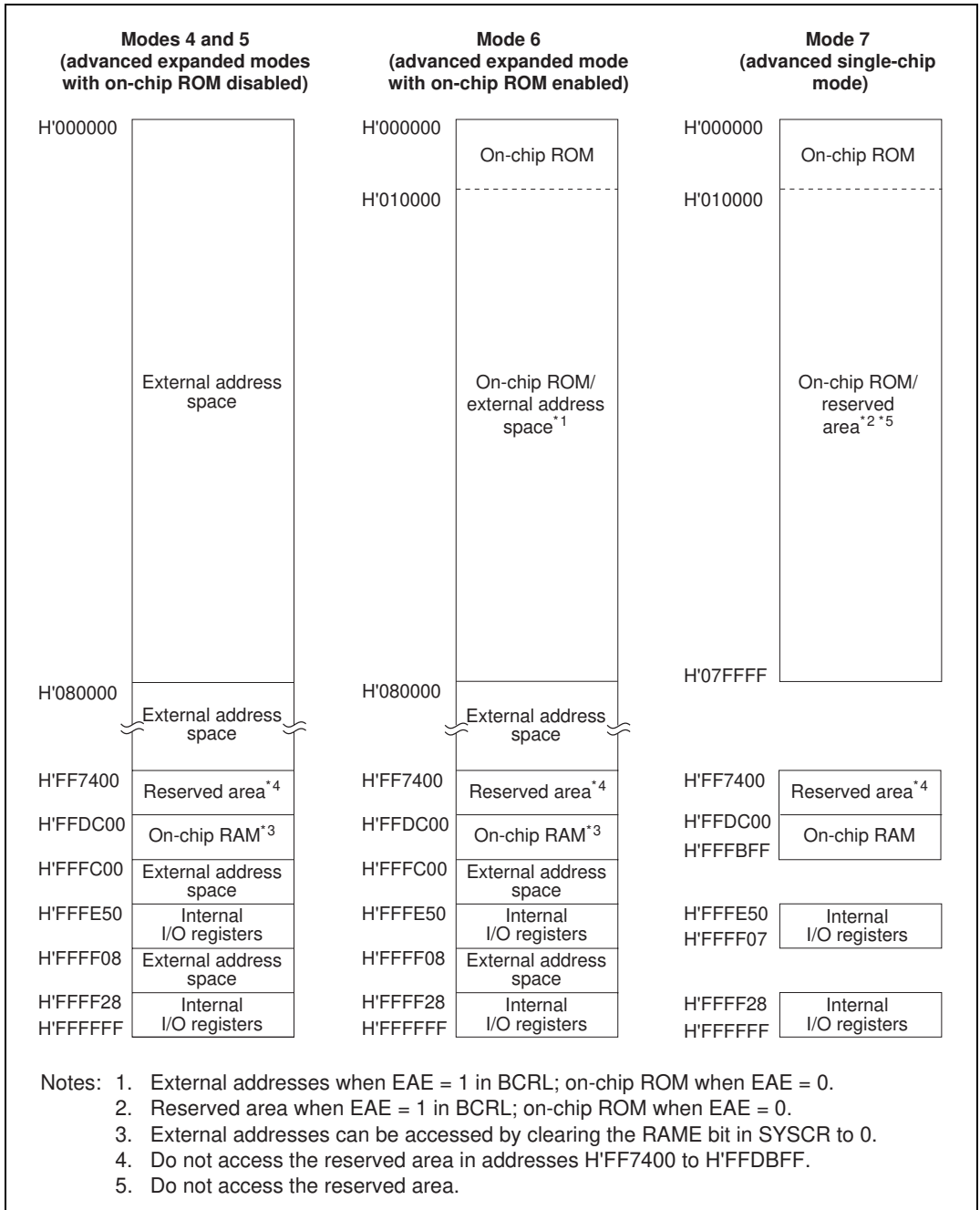

Figure 3.1 (b) H8S/2319 Memory Map in Each Operating Mode

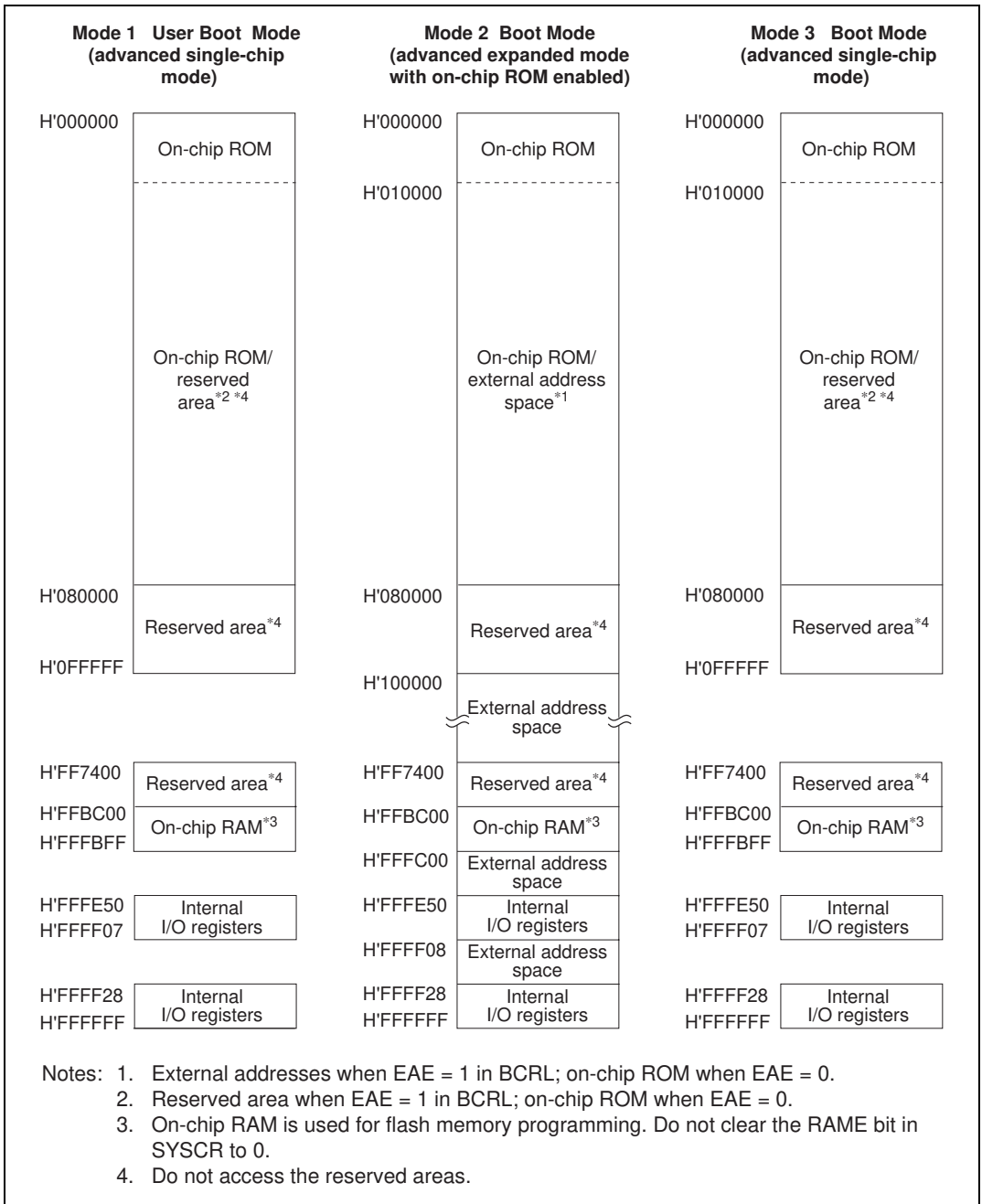

Figure 3.2 (a) H8S/2319C F-ZTAT Memory Map in Each Operating Mode

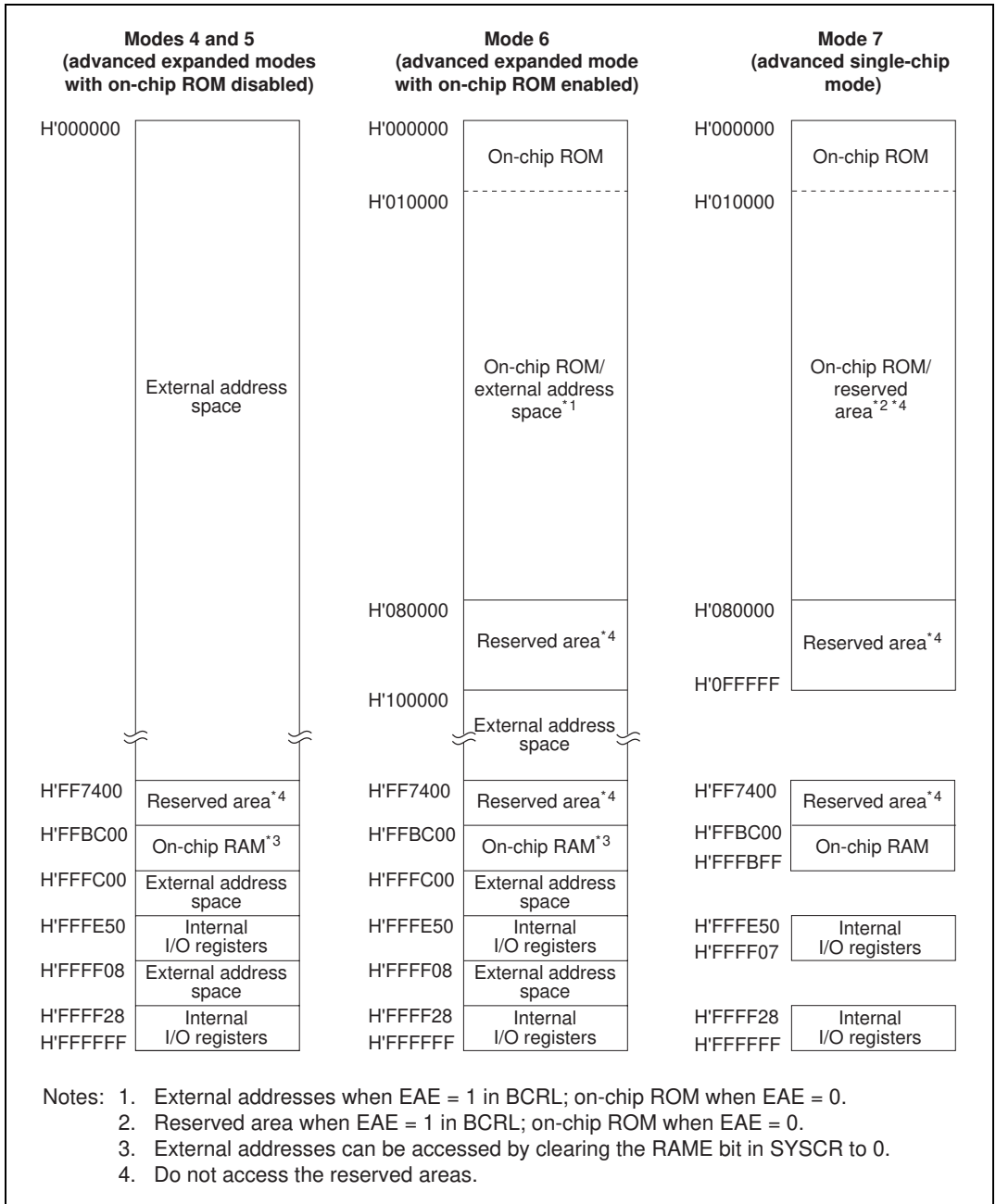

Figure 3.2 (b) H8S/2319C F-ZTAT Memory Map in Each Operating Mode

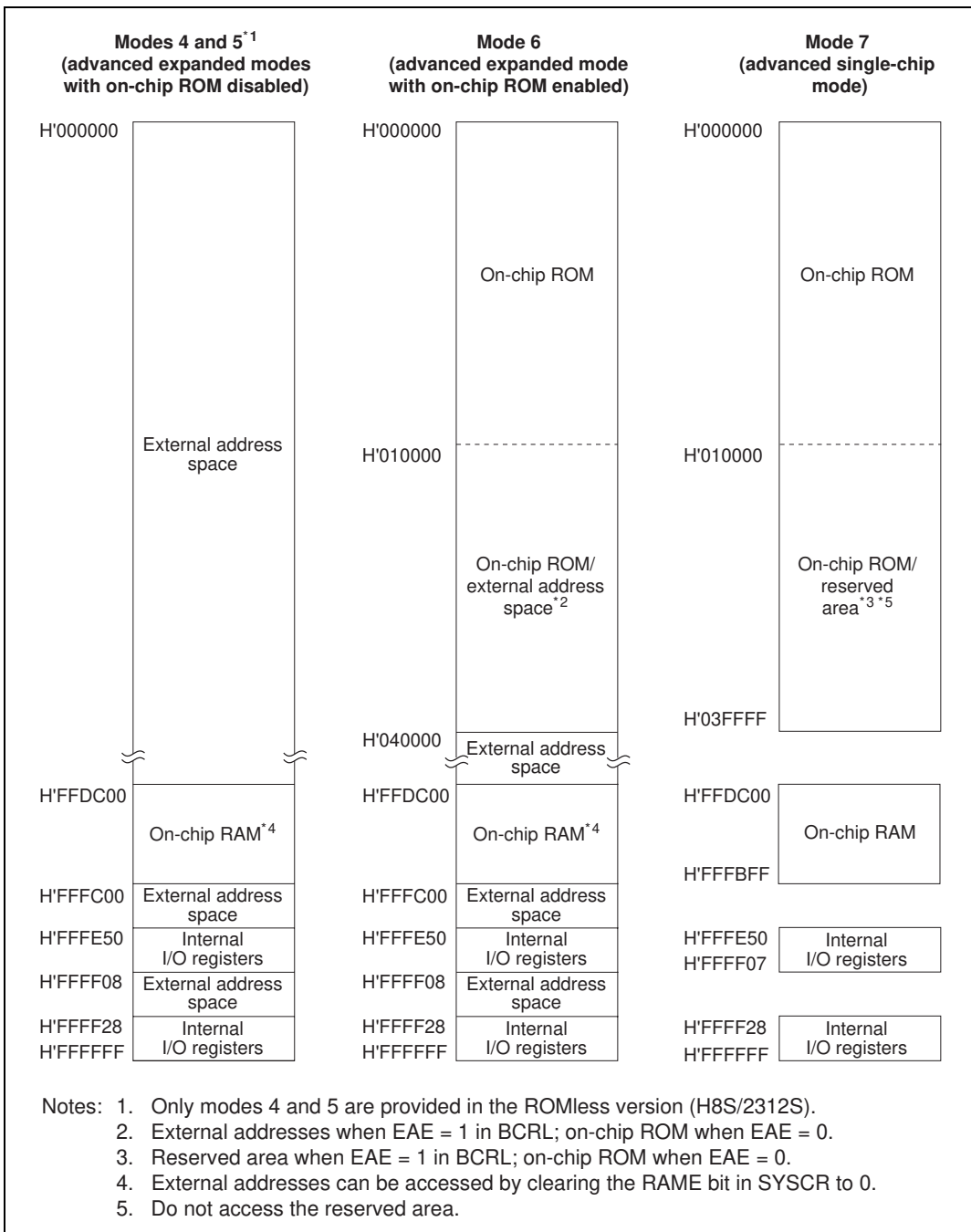
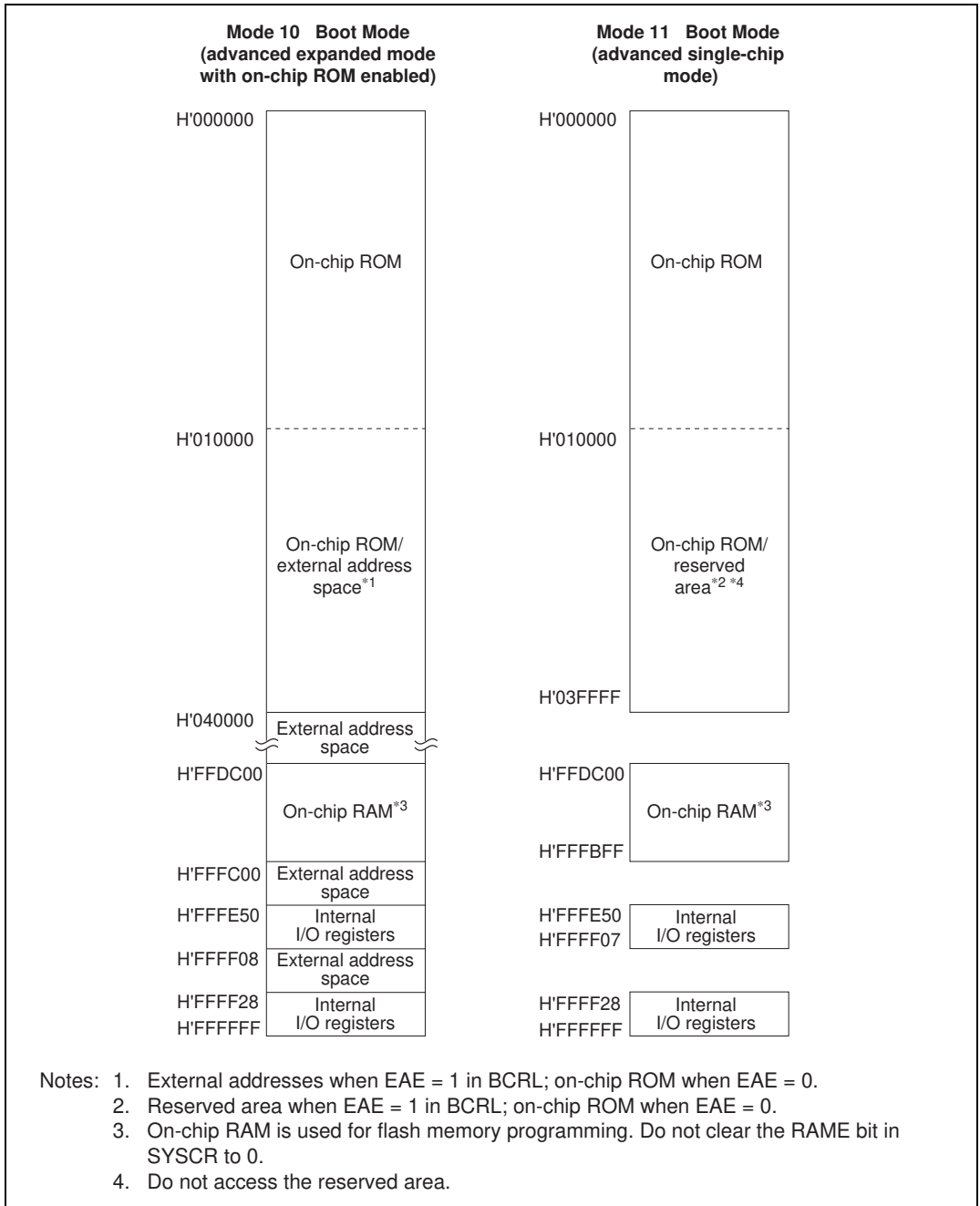
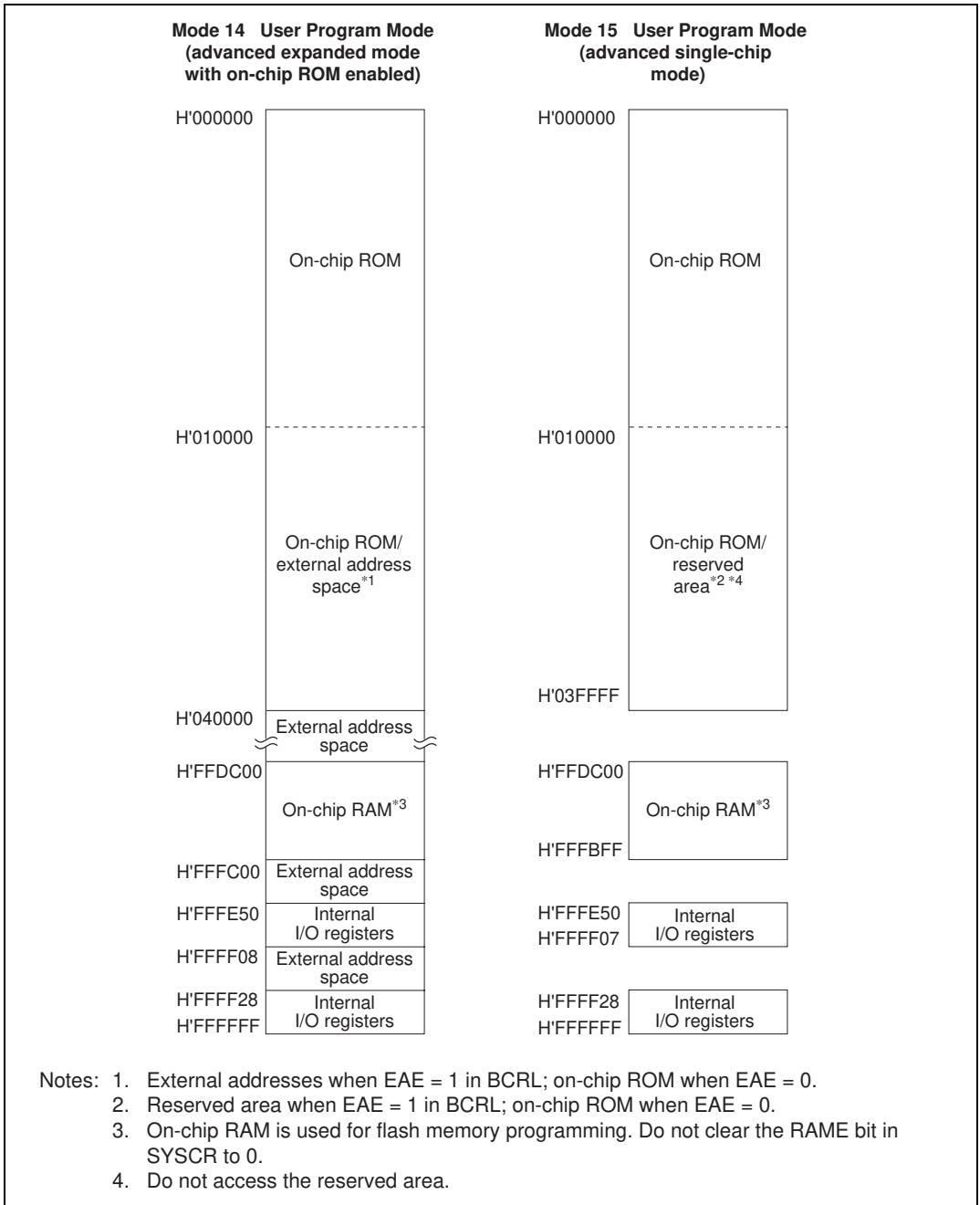

Figure 3.3 (a) H8S/2318 and H8S/2312S Memory Map in Each Operating Mode



**Figure 3.3 (b) H8S/2318 Memory Map in Each Operating Mode
(F-ZTAT Version Only)**



**Figure 3.3 (c) H8S/2318 Memory Map in Each Operating Mode
(F-ZTAT Version Only)**

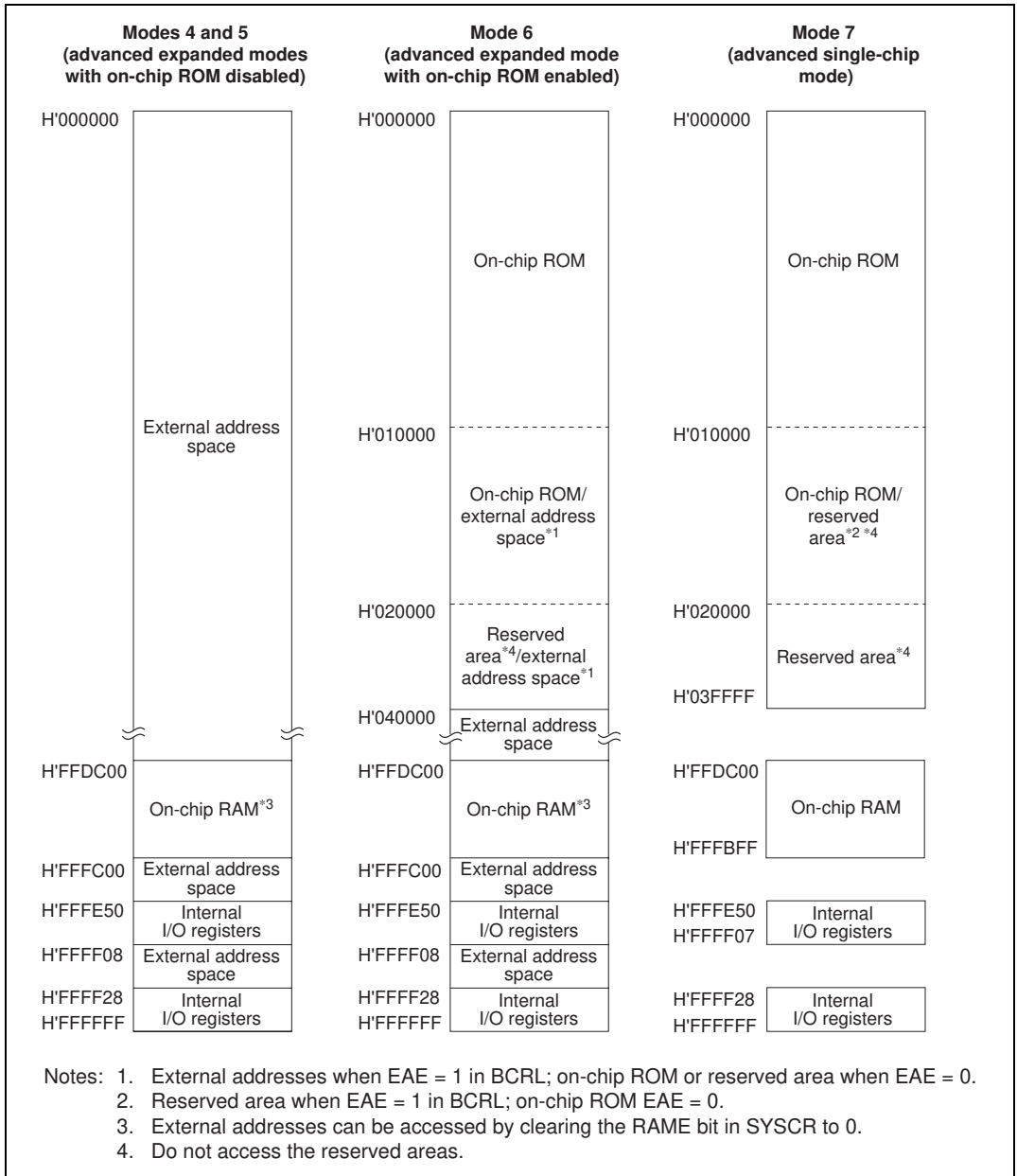
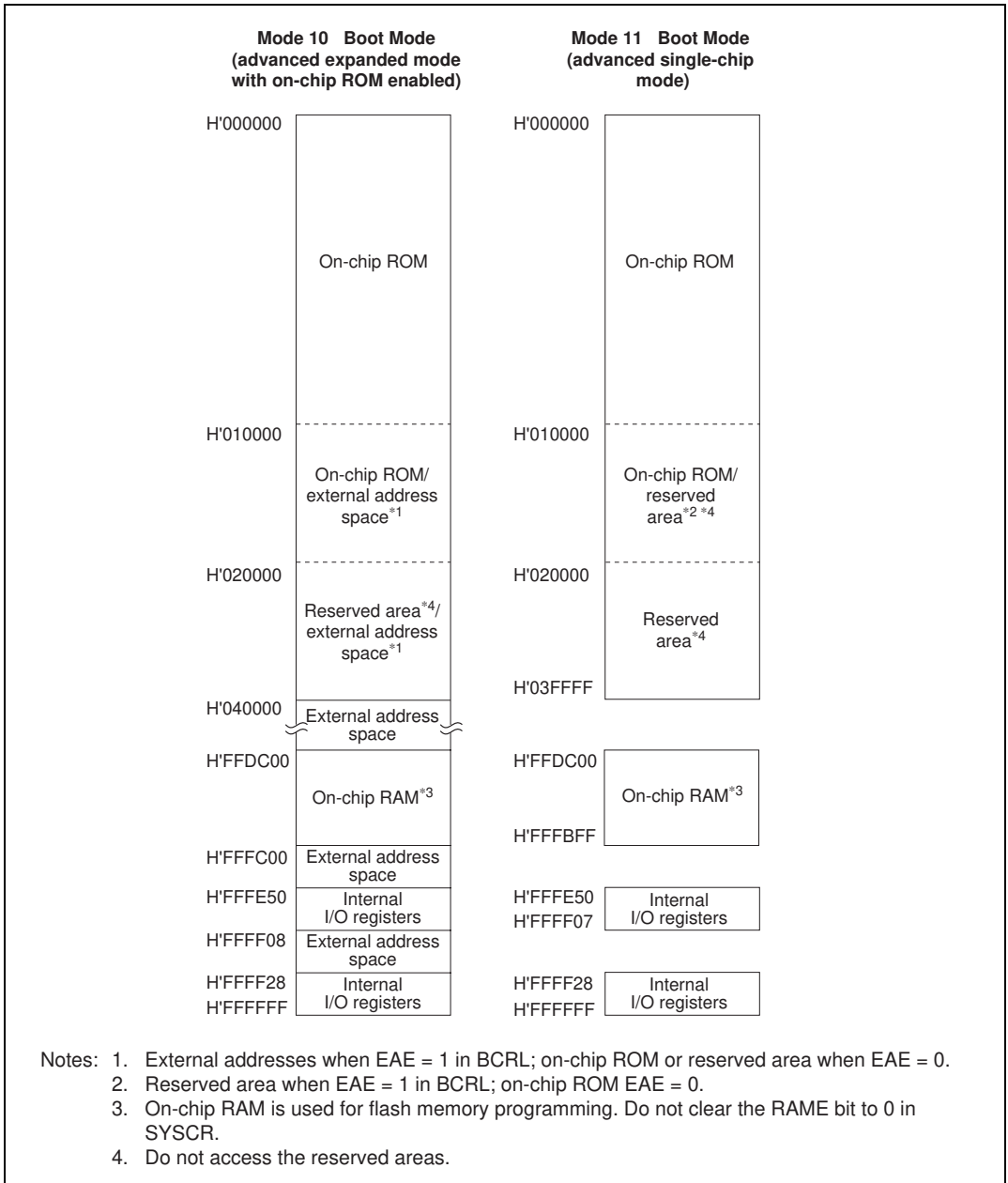
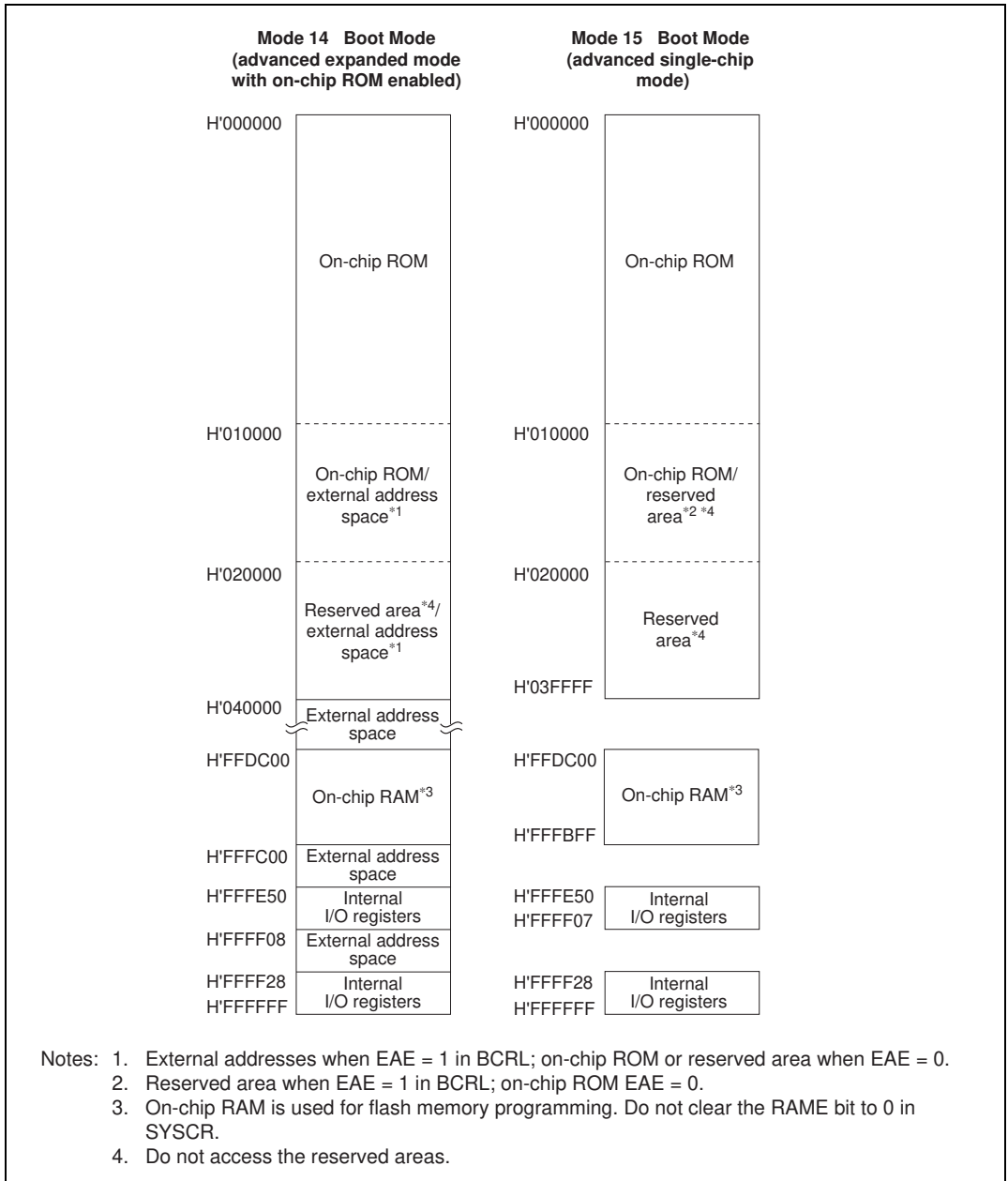

Figure 3.4 (a) H8S/2317(S) Memory Map in Each Operating Mode



**Figure 3.4 (b) H8S/2317 Memory Map in Each Operating Mode
(F-ZTAT Version Only)**



**Figure 3.4 (c) H8S/2317 Memory Map in Each Operating Mode
(F-ZTAT Version Only)**

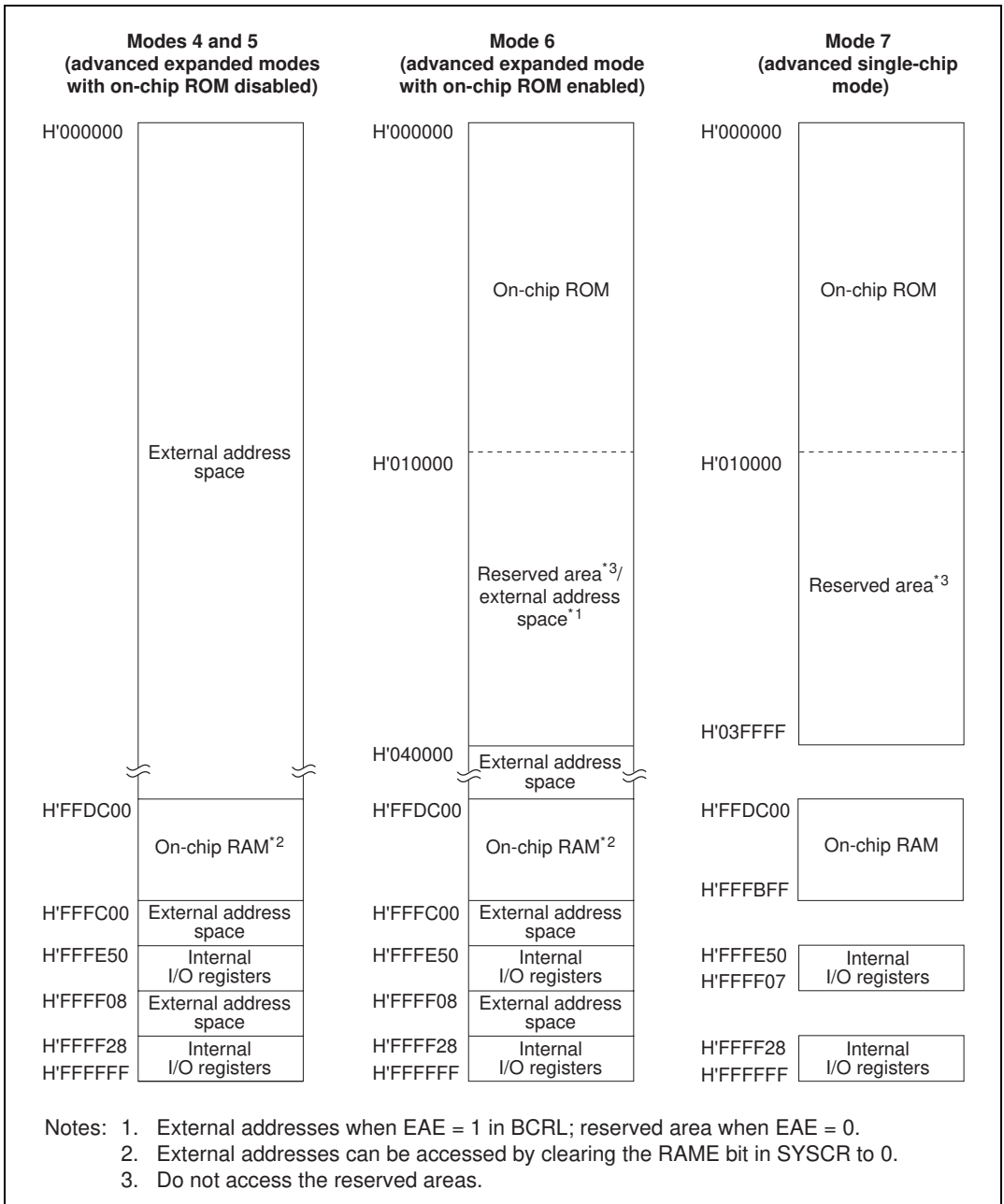

Figure 3.5 H8S/2316S Memory Map in Each Operating Mode

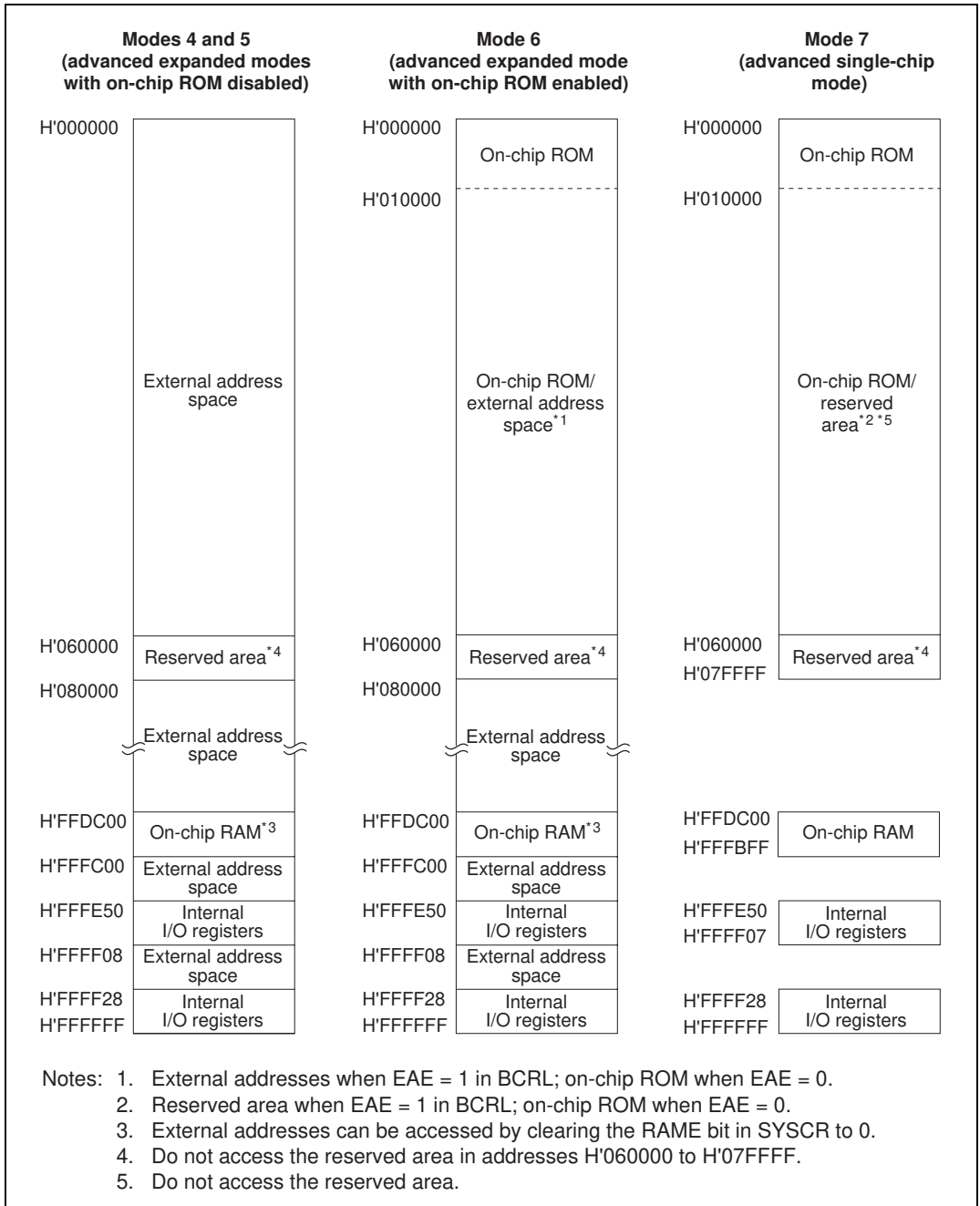

Figure 3.6 (a) H8S/2315 Memory Map in Each Operating Mode

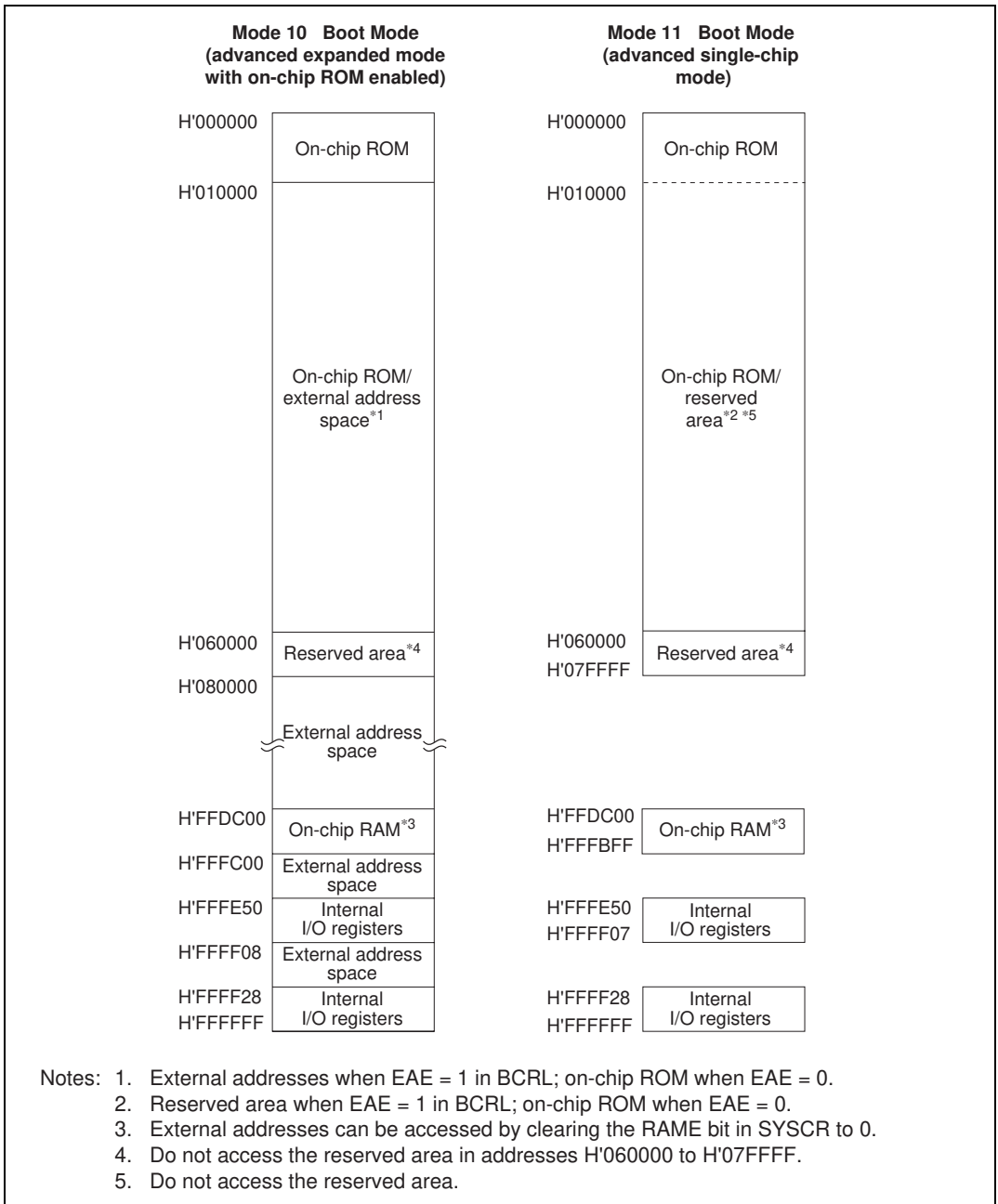

Figure 3.6 (b) H8S/2315 Memory Map in Each Operating Mode (F-ZTAT Version Only)

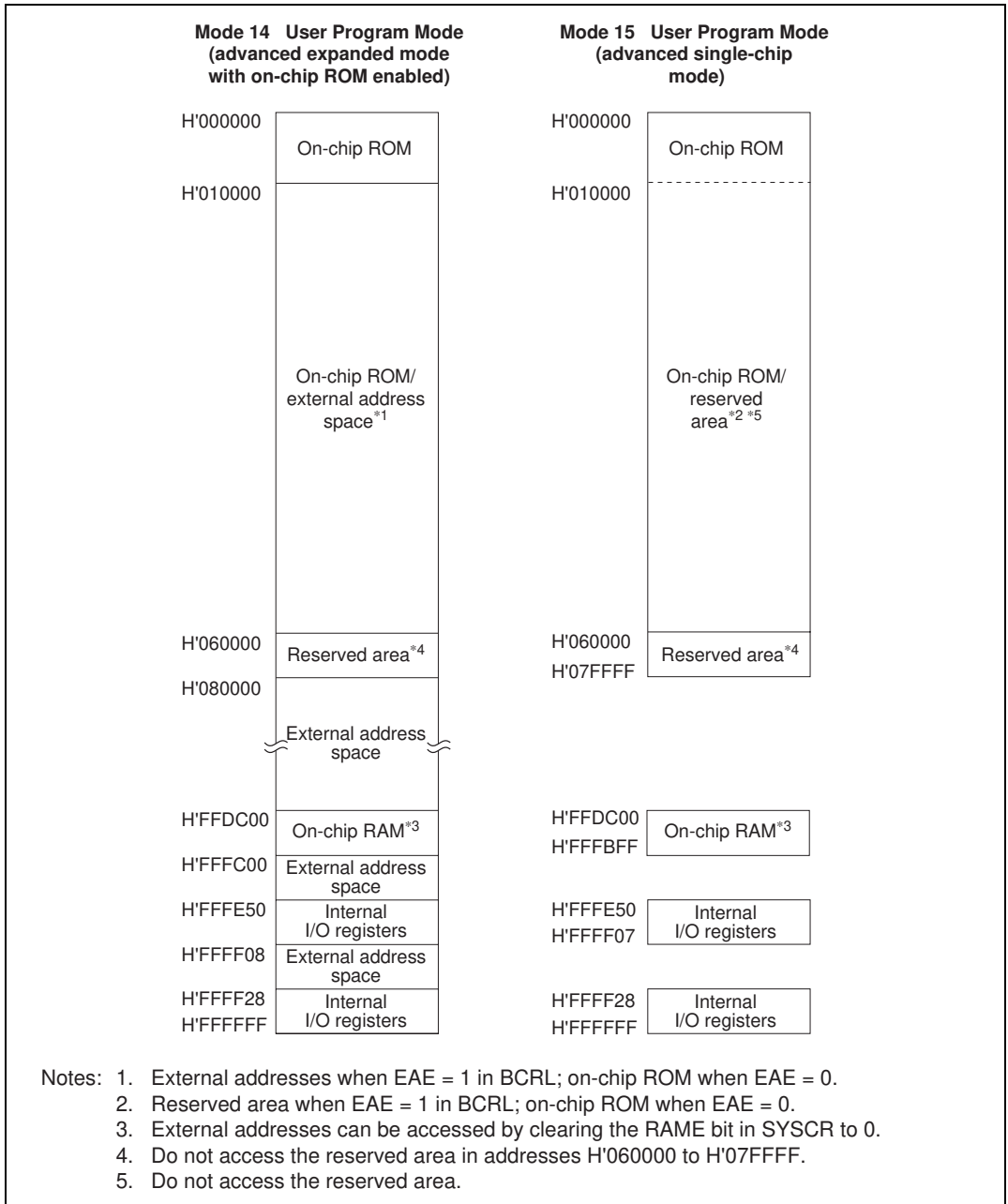

Figure 3.6 (c) H8S/2315 Memory Map in Each Operating Mode (F-ZTAT Version Only)

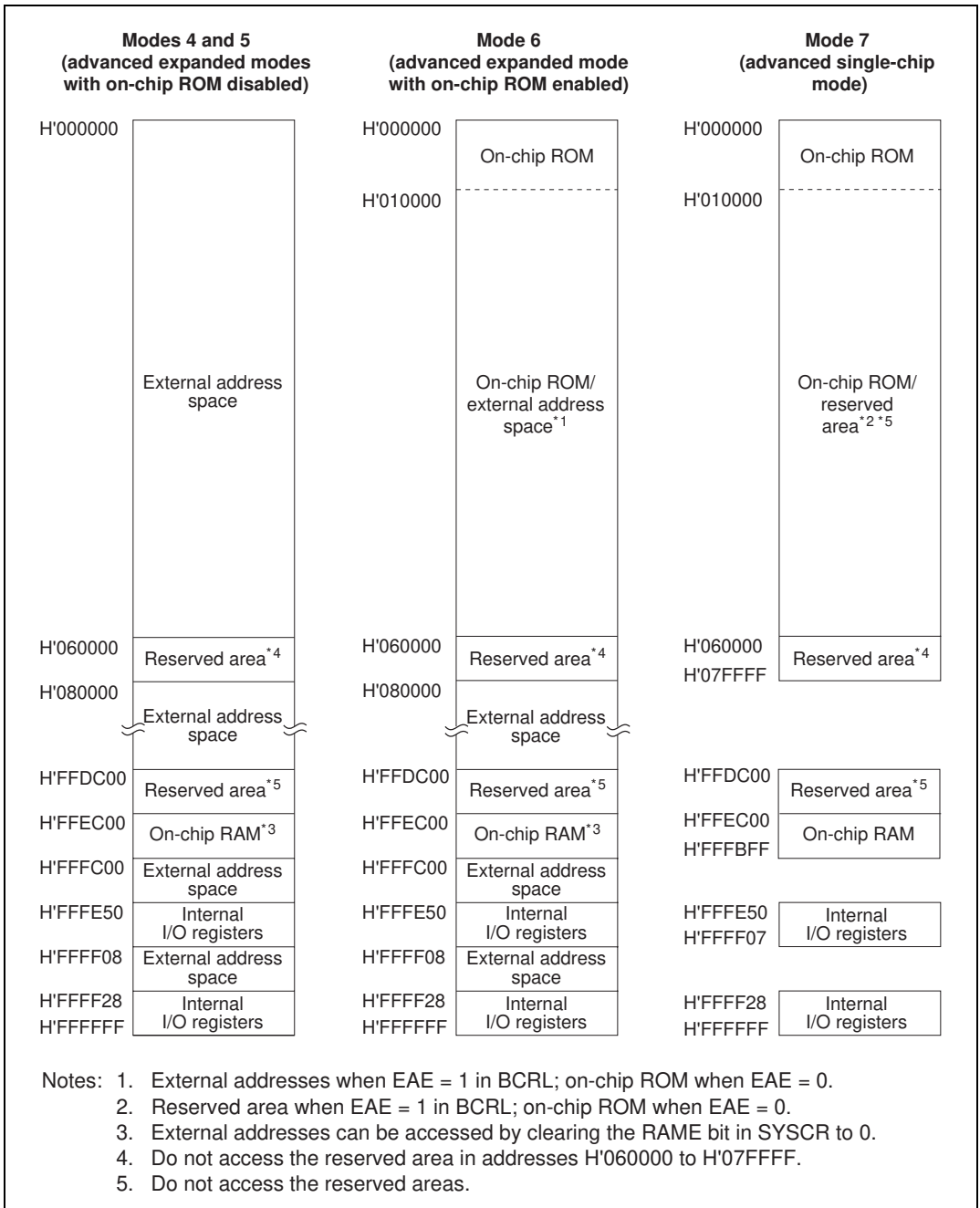

Figure 3.7 (a) H8S/2314 Memory Map in Each Operating Mode

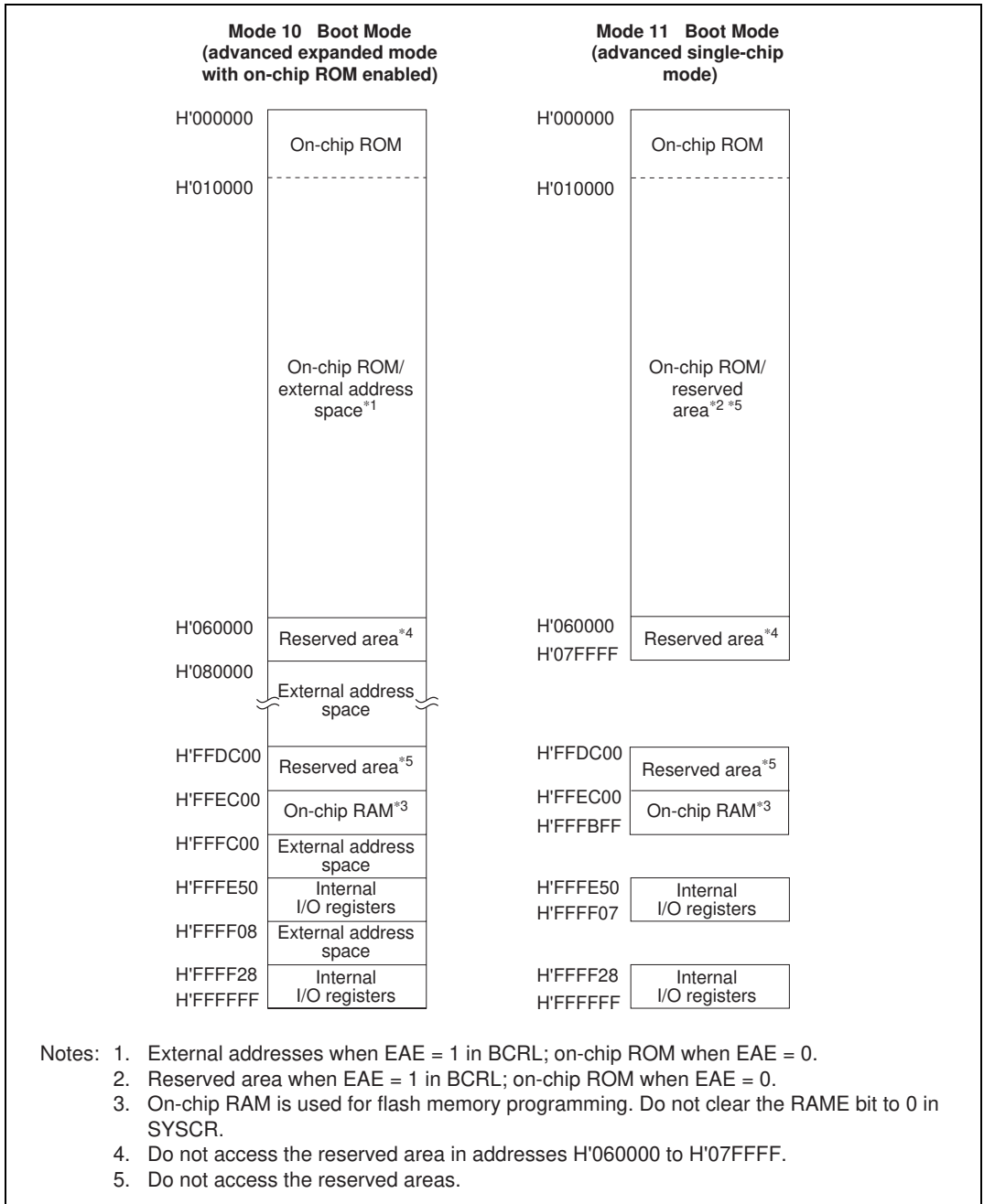

Figure 3.7 (b) H8S/2314 Memory Map in Each Operating Mode (F-ZTAT Version Only)

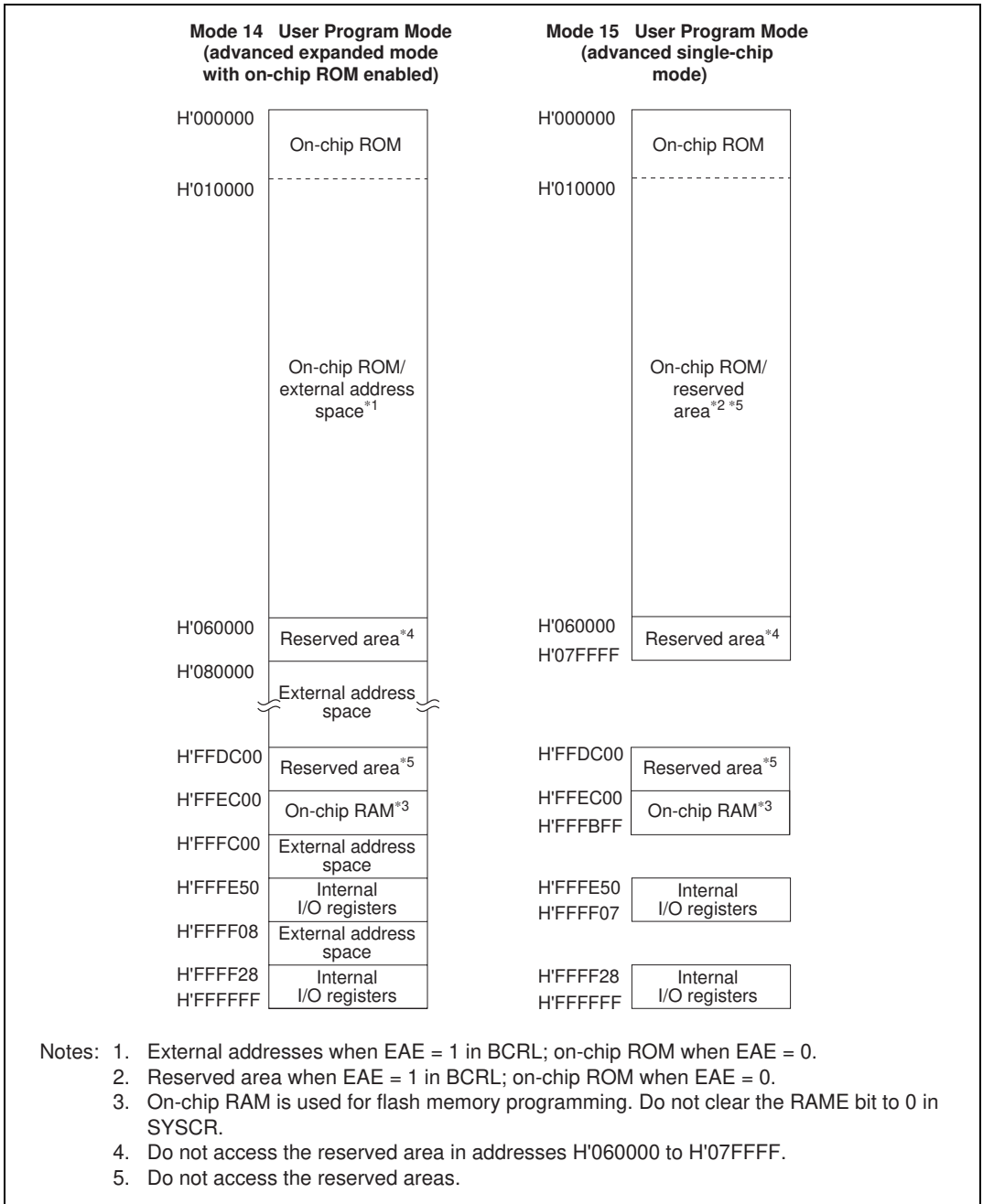

Figure 3.7 (c) H8S/2314 Memory Map in Each Operating Mode (F-ZTAT Version Only)

Section 4 Exception Handling

4.1 Overview

4.1.1 Exception Handling Types and Priority

As table 4.1 indicates, exception handling may be caused by a reset, trap instruction, or interrupt. Exception handling is prioritized as shown in table 4.1. If two or more exceptions occur simultaneously, they are accepted and processed in order of priority. Trap instruction exceptions are accepted at all times in the program execution state.

Exception handling sources, the stack structure, and the operation of the CPU vary depending on the interrupt control mode set by the INTM0 and INTM1 bits of SYSCR.

Table 4.1 Exception Types and Priority

Priority	Exception Type	Start of Exception Handling
High ↑	Reset	Starts immediately after a low-to-high transition at the \overline{RES} pin, or when the watchdog timer overflows.
	Trace ^{*1}	Starts when execution of the current instruction or exception handling ends, if the trace (T) bit is set to 1
	Interrupt	Starts when execution of the current instruction or exception handling ends, if an interrupt request has been issued ^{*2}
Low	Trap instruction (TRAPA) ^{*3}	Started by execution of a trap instruction (TRAPA)

- Notes: 1. Traces are enabled only in interrupt control mode 2. Trace exception handling is not executed after execution of an RTE instruction.
2. Interrupt detection is not performed on completion of ANDC, ORC, XORC, or LDC instruction execution, or on completion of reset exception handling.
3. Trap instruction exception handling requests are accepted at all times in the program execution state.

4.1.2 Exception Handling Operation

Exceptions originate from various sources. Trap instructions and interrupts are handled as follows:

1. The program counter (PC), condition code register (CCR), and extend register (EXR) are pushed onto the stack.
2. The interrupt mask bits are updated. The T bit is cleared to 0.
3. A vector address corresponding to the exception source is generated, and program execution starts from that address.

For a reset exception, steps 2 and 3 above are carried out.

4.1.3 Exception Vector Table

The exception sources are classified as shown in figure 4.1. Different vector addresses are assigned to different exception sources.

Table 4.2 lists the exception sources and their vector addresses.

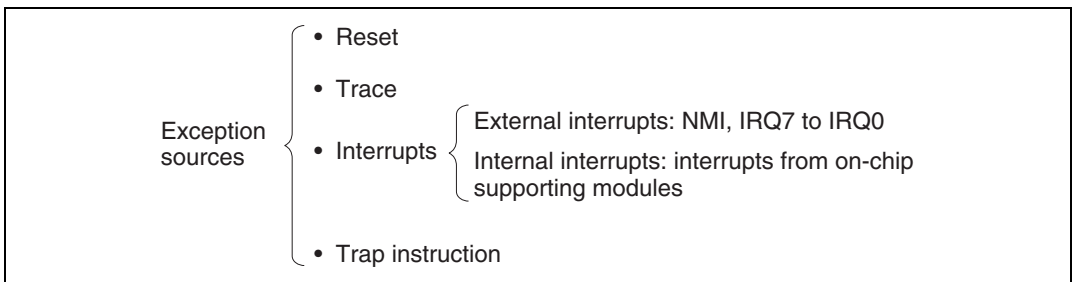

Figure 4.1 Exception Sources

In modes 6 and 7, the on-chip ROM available for use after a power-on reset is the 64-kbyte area comprising addresses H'000000 to H'00FFFF. Care is required when setting vector addresses. In this case, clearing the EAE bit in BCRL enables the 256-kbyte (128 kbytes/384 kbytes/512 kbytes) area* comprising addresses H'000000 to H'03FFFF (to H'01FFFF/H'05FFFF/H'07FFFF) to be used.

Note: * The different have different amounts of on-chip ROM. For details, see section 6.2.5, Bus Control Register L (BCRL).

Table 4.2 Exception Vector Table

Exception Source	Vector Number	Vector Address*1	
		Advanced Mode	
Reset	0	H'0000 to H'0003	
Reserved	1	H'0004 to H'0007	
Reserved for system use	2	H'0008 to H'000B	
	3	H'000C to H'000F	
	4	H'0010 to H'0013	
Trace	5	H'0014 to H'0017	
Reserved for system use	6	H'0018 to H'001B	
External interrupt NMI	7	H'001C to H'001F	
Trap instruction (4 sources)	8	H'0020 to H'0023	
	9	H'0024 to H'0027	
	10	H'0028 to H'002B	
	11	H'002C to H'002F	
Reserved for system use	12	H'0030 to H'0033	
	13	H'0034 to H'0037	
	14	H'0038 to H'003B	
	15	H'003C to H'003F	
External interrupt	IRQ0	16	H'0040 to H'0043
	IRQ1	17	H'0044 to H'0047
	IRQ2	18	H'0048 to H'004B
	IRQ3	19	H'004C to H'004F
	IRQ4	20	H'0050 to H'0053
	IRQ5	21	H'0054 to H'0057
	IRQ6	22	H'0058 to H'005B
	IRQ7	23	H'005C to H'005F
Internal interrupt*2	24	H'0060 to H'0063	
	91	H'016C to H'016F	

Notes: 1. Lower 16 bits of the address.

2. For details of internal interrupt vectors, see section 5.3.3, Interrupt Exception Vector Table.

4.2 Reset

4.2.1 Overview

A reset has the highest exception priority.

When the $\overline{\text{RES}}$ pin goes low, all processing halts and the chip enters the reset state. A reset initializes the internal state of the CPU and the registers of on-chip supporting modules. Immediately after a reset, interrupt control mode 0 is set.

Reset exception handling begins when the $\overline{\text{RES}}$ pin changes from low to high.

A reset can also be caused by watchdog timer overflow. For details see section 11, Watchdog Timer.

4.2.2 Reset Sequence

The chip enters the reset state when the $\overline{\text{RES}}$ pin goes low.

To ensure that the chip is reset, hold the $\overline{\text{RES}}$ pin low for at least 20 ms at power-up. To reset the chip during operation, hold the $\overline{\text{RES}}$ pin low for at least 20 states.

When the $\overline{\text{RES}}$ pin goes high after being held low for the necessary time, the chip starts reset exception handling as follows:

1. The internal state of the CPU and the registers of the on-chip supporting modules are initialized, the T bit is cleared to 0 in EXR, and the I bit is set to 1 in EXR and CCR.
2. The reset exception vector address is read and transferred to the PC, and program execution starts from the address indicated by the PC.

Figure 4.2 shows an example of the reset sequence.

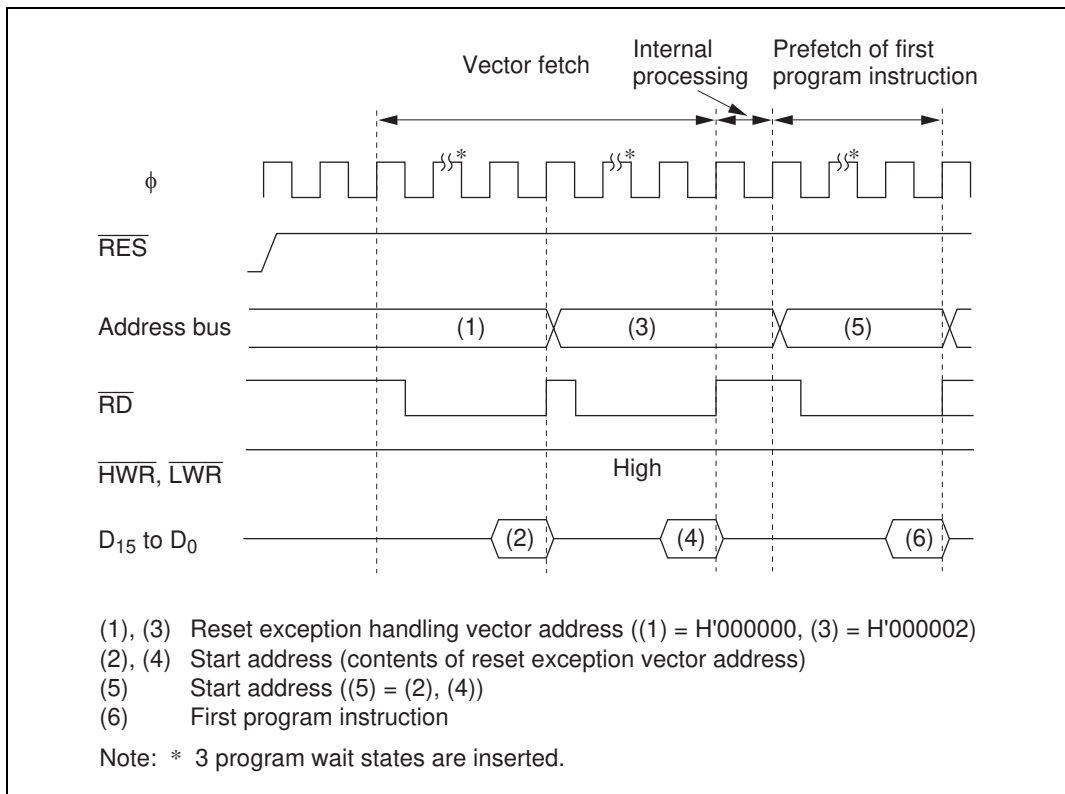

Figure 4.2 Reset Sequence (Mode 4)

4.2.3 Interrupts after Reset

If an interrupt is accepted after a reset but before the stack pointer (SP) is initialized, the PC and CCR will not be saved correctly, leading to a program crash. To prevent this, all interrupt requests, including NMI, are disabled immediately after a reset. Since the first instruction of a program is always executed immediately after the reset state ends, make sure that this instruction initializes the stack pointer (example: `MOV.L #xx:32, SP`).

4.2.4 State of On-Chip Supporting Modules after Reset Release

After reset release, MSTPCR is initialized to H'3FFF and all modules except the DTC enter module stop mode. Consequently, on-chip supporting module registers cannot be read or written to. Register reading and writing is enabled when module stop mode is exited.

4.3 Traces

Traces are enabled in interrupt control mode 2. Trace mode is not activated in interrupt control mode 0, irrespective of the state of the T bit. For details of interrupt control modes, see section 5, Interrupt Controller.

If the T bit in EXR is set to 1, trace mode is activated. In trace mode, a trace exception occurs on completion of each instruction.

Trace mode is canceled by clearing the T bit in EXR to 0. It is not affected by interrupt masking.

Table 4.3 shows the state of CCR and EXR after execution of trace exception handling.

Interrupts are accepted even within the trace exception handling routine.

The T bit saved on the stack retains its value of 1, and when control is returned from the trace exception handling routine by the RTE instruction, trace mode resumes.

Trace exception handling is not carried out after execution of the RTE instruction.

Table 4.3 Status of CCR and EXR after Trace Exception Handling

Interrupt Control Mode	CCR		EXR	
	I	UI	I2 to I0	T
0	Trace exception handling cannot be used.			
2	1	—	—	0

Legend:

1: Set to 1

0: Cleared to 0

—: Retains value prior to execution.

4.4 Interrupts

Interrupt exception handling can be requested by nine external sources (NMI, IRQ7 to IRQ0) and 43 internal sources in the on-chip supporting modules. Figure 4.3 classifies the interrupt sources and the number of interrupts of each type.

The on-chip supporting modules that can request interrupts include the watchdog timer (WDT), 16-bit timer-pulse unit (TPU), 8-bit timer, serial communication interface (SCI), data transfer controller (DTC), and A/D converter. Each interrupt source has a separate vector address.

NMI is the highest-priority interrupt. Interrupts are controlled by the interrupt controller. The interrupt controller has two interrupt control modes and can assign interrupts other than NMI to eight priority/mask levels to enable multiplexed interrupt control.

For details of interrupts, see section 5, Interrupt Controller.

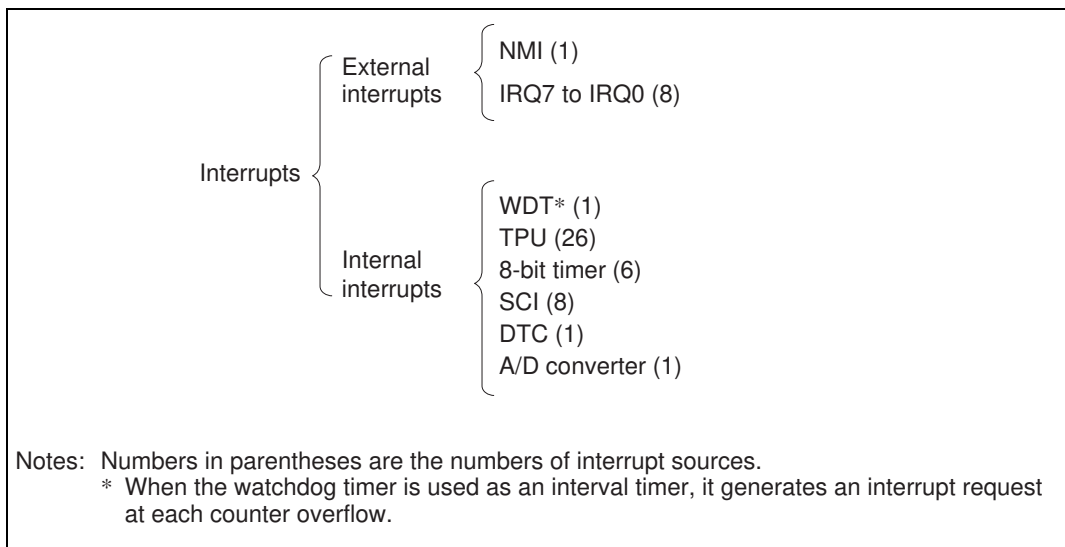

Figure 4.3 Interrupt Sources and Number of Interrupts

4.5 Trap Instruction

Trap instruction exception handling starts when a TRAPA instruction is executed. Trap instruction exception handling can be executed at all times in the program execution state.

The TRAPA instruction fetches a start address from a vector table entry corresponding to a vector number from 0 to 3, as specified in the instruction code.

Table 4.4 shows the status of CCR and EXR after execution of trap instruction exception handling.

Table 4.4 Status of CCR and EXR after Trap Instruction Exception Handling

Interrupt Control Mode	CCR		EXR	
	I	UI	I2 to I0	T
0	1	—	—	—
2	1	—	—	0

Legend:

1: Set to 1

0: Cleared to 0

—: Retains value prior to execution.

4.6 Stack Status after Exception Handling

Figure 4.4 shows the stack after completion of trap instruction exception handling and interrupt exception handling.

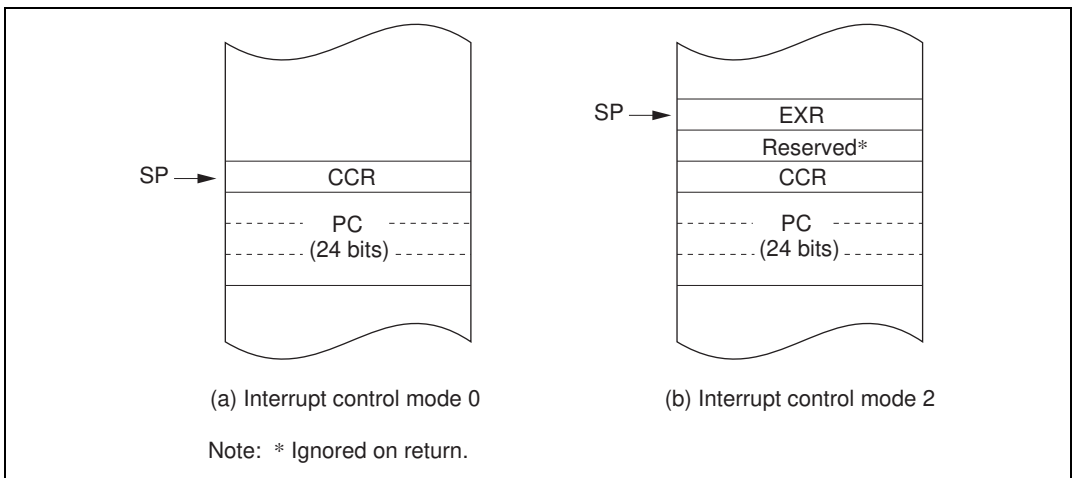

Figure 4.4 Stack Status after Exception Handling (Advanced Modes)

4.7 Notes on Use of the Stack

When accessing word data or longword data, the chip assumes that the lowest address bit is 0. The stack should always be accessed by word transfer instruction or longword transfer instruction, and the value of the stack pointer (SP, ER7) should always be kept even. Use the following instructions to save registers:

```
PUSH.W   Rn      (or MOV.W Rn, @-SP)
PUSH.L   ERn     (or MOV.L ERn, @-SP)
```

Use the following instructions to restore registers:

```
POP.W    Rn      (or MOV.W @SP+, Rn)
POP.L    ERn     (or MOV.L @SP+, ERn)
```

Setting SP to an odd value may lead to a malfunction. Figure 4.5 shows an example of what happens when the SP value is odd.

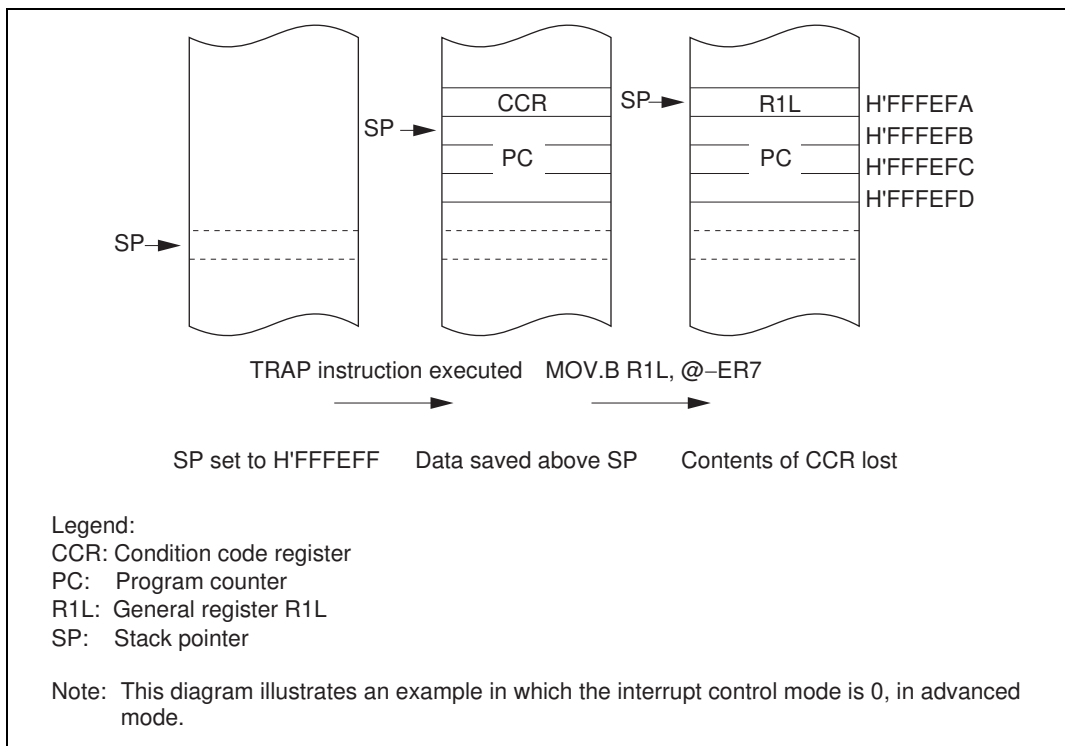

Figure 4.5 Operation when SP Value is Odd

Section 5 Interrupt Controller

5.1 Overview

5.1.1 Features

The chip controls interrupts by means of an interrupt controller. The interrupt controller has the following features. The available interrupt sources are external interrupts (NMI, IRQ7 to IRQ0) and internal interrupts (43 sources).

- Two interrupt control modes
 - Either of two interrupt control modes can be set by means of the INTM1 and INTM0 bits in the system control register (SYSCR)
- Priorities settable with IPRs
 - Interrupt priority registers (IPRs) are provided for setting interrupt priorities. Eight priority levels can be set for each module for all interrupts except NMI
 - NMI is assigned the highest priority level of 8, and can be accepted at all times
- Independent vector addresses
 - All interrupt sources are assigned independent vector addresses, making it unnecessary for the source to be identified in the interrupt handling routine
- Nine external interrupt pins
 - NMI is the highest-priority interrupt, and is accepted at all times. Rising edge or falling edge can be selected for NMI
 - Falling edge, rising edge, or both edge detection, or level sensing, can be selected for IRQ7 to IRQ0
- DTC control
 - DTC activation is controlled by means of interrupts

5.1.2 Block Diagram

A block diagram of the interrupt controller is shown in figure 5.1.

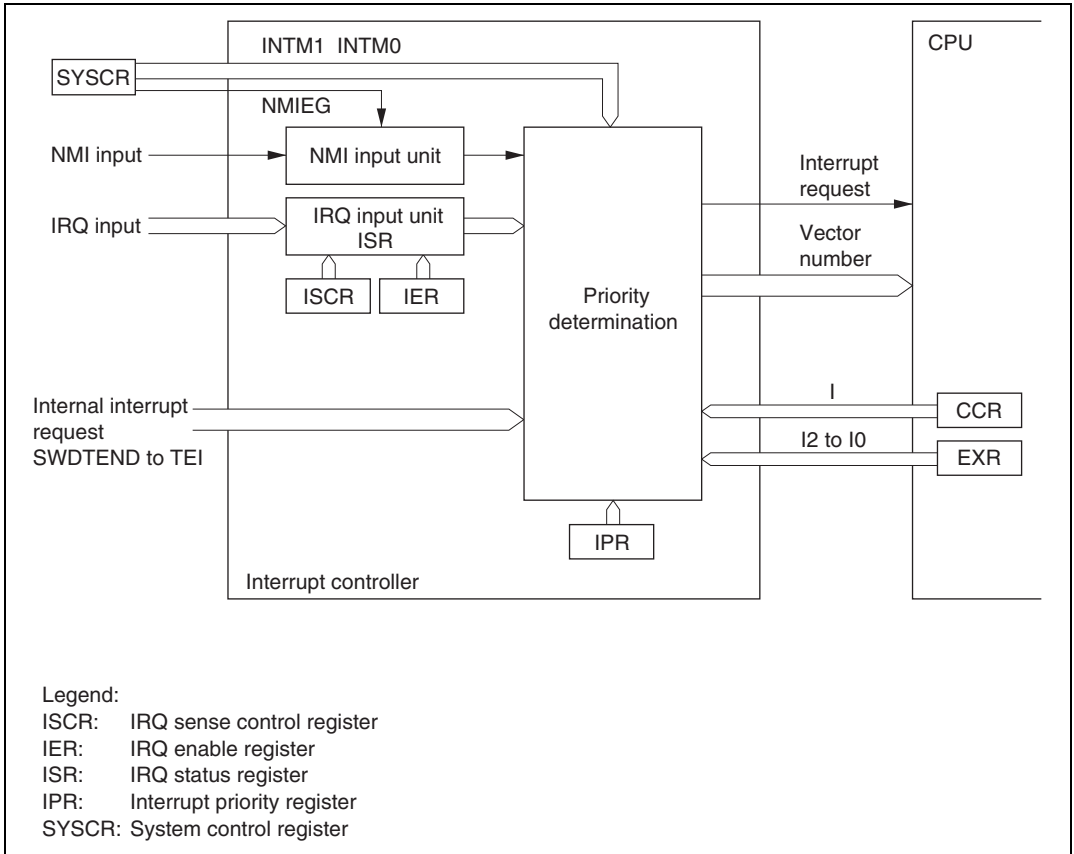

Figure 5.1 Block Diagram of Interrupt Controller

5.1.3 Pin Configuration

Table 5.1 summarizes the pins of the interrupt controller.

Table 5.1 Interrupt Controller Pins

Name	Symbol	I/O	Function
Nonmaskable interrupt	NMI	Input	Nonmaskable external interrupt; rising or falling edge can be selected
External interrupt requests 7 to 0	$\overline{\text{IRQ7}}$ to $\overline{\text{IRQ0}}$	Input	Maskable external interrupts; rising, falling, or both edges, or level sensing, can be selected

5.1.4 Register Configuration

Table 5.2 summarizes the registers of the interrupt controller.

Table 5.2 Interrupt Controller Registers

Name	Abbreviation	R/W	Initial Value	Address ^{*1}
System control register	SYSCR	R/W	H'01	H'FF39
IRQ sense control register H	ISCRH	R/W	H'00	H'FF2C
IRQ sense control register L	ISCLR	R/W	H'00	H'FF2D
IRQ enable register	IER	R/W	H'00	H'FF2E
IRQ status register	ISR	R/(W) ^{*2}	H'00	H'FF2F
Interrupt priority register A	IPRA	R/W	H'77	H'FEC4
Interrupt priority register B	IPRB	R/W	H'77	H'FEC5
Interrupt priority register C	IPRC	R/W	H'77	H'FEC6
Interrupt priority register D	IPRD	R/W	H'77	H'FEC7
Interrupt priority register E	IPRE	R/W	H'77	H'FEC8
Interrupt priority register F	IPRF	R/W	H'77	H'FEC9
Interrupt priority register G	IPRG	R/W	H'77	H'FECA
Interrupt priority register H	IPRH	R/W	H'77	H'FECB
Interrupt priority register I	IPRI	R/W	H'77	H'FECC
Interrupt priority register J	IPRJ	R/W	H'77	H'FECD
Interrupt priority register K	IPRK	R/W	H'77	H'FECE

Notes: 1. Lower 16 bits of the address.

2. Can only be written with 0 for flag clearing.

5.2 Register Descriptions

5.2.1 System Control Register (SYSCR)

Bit	:	7	6	5	4	3	2	1	0
		—	—	INTM1	INTM0	NMIEG	LWROD	—	RAME
Initial value :		0	0	0	0	0	0	0	1
R/W	:	R/W	—	R/W	R/W	R/W	R/W	R/W	R/W

SYSCR is an 8-bit readable/writable register that selects the interrupt control mode, and the detected edge for NMI.

Only bits 5 to 3 are described here; for details of the other bits, see section 3, MCU Operating Modes.

SYSCR is initialized to H'01 by a reset and in hardware standby mode. It is not initialized in software standby mode.

Bits 5 and 4—Interrupt Control Mode 1 and 0 (INTM1, INTM0): These bits select one of two interrupt control modes for the interrupt controller.

Bit 5 INTM1	Bit 4 INTM0	Interrupt Control Mode	Description
0	0	0	Interrupts are controlled by I bit (Initial value)
	1	—	Setting prohibited
1	0	2	Interrupts are controlled by bits I2 to I0, and IPR
	1	—	Setting prohibited

Bit 3—NMI Edge Select (NMIEG): Selects the input edge for the NMI pin.

Bit 3 NMIEG	Description
0	Interrupt request generated at falling edge of NMI input (Initial value)
1	Interrupt request generated at rising edge of NMI input

5.2.2 Interrupt Priority Registers A to K (IPRA to IPRK)

Bit	:	7	6	5	4	3	2	1	0
		—	IPR6	IPR5	IPR4	—	IPR2	IPR1	IPR0
Initial value	:	0	1	1	1	0	1	1	1
R/W	:	—	R/W	R/W	R/W	—	R/W	R/W	R/W

The IPR registers are eleven 8-bit readable/writable registers that set priorities (levels 7 to 0) for interrupts other than NMI.

The correspondence between IPR settings and interrupt sources is shown in table 5.3.

The IPR registers set a priority (levels 7 to 0) for each interrupt source other than NMI.

The IPR registers are initialized to H'77 by a reset and in hardware standby mode.

Bits 7 and 3—Reserved: Read-only bits, always read as 0.

Table 5.3 Correspondence between Interrupt Sources and IPR Settings

Register	Bits	
	6 to 4	2 to 0
IPRA	IRQ0	IRQ1
IPRB	IRQ2	IRQ4
	IRQ3	IRQ5
IPRC	IRQ6	DTC
	IRQ7	
IPRD	Watchdog timer	—*
IPRE	—*	A/D converter
IPRF	TPU channel 0	TPU channel 1
IPRG	TPU channel 2	TPU channel 3
IPRH	TPU channel 4	TPU channel 5
IPRI	8-bit timer channel 0	8-bit timer channel 1
IPRJ	—*	SCI channel 0
IPRK	SCI channel 1	—*

Note: * Reserved bits.

As shown in table 5.3, multiple interrupts are assigned to one IPR. Setting a value in the range from H'0 to H'7 in the 3-bit groups of bits 6 to 4 and 2 to 0 sets the priority of the corresponding interrupt. The lowest priority level, level 0, is assigned by setting H'0, and the highest priority level, level 7, by setting H'7.

When interrupt requests are generated, the highest-priority interrupt according to the priority levels set in the IPR registers is selected. This interrupt level is then compared with the interrupt mask level set by the interrupt mask bits (I2 to I0) in the extend register (EXR) in the CPU, and if the priority level of the interrupt is higher than the set mask level, an interrupt request is issued to the CPU.

5.2.3 IRQ Enable Register (IER)

Bit	:	7	6	5	4	3	2	1	0
		IRQ7E	IRQ6E	IRQ5E	IRQ4E	IRQ3E	IRQ2E	IRQ1E	IRQ0E
Initial value	:	0	0	0	0	0	0	0	0
R/W	:	R/W	R/W	R/W	R/W	R/W	R/W	R/W	R/W

IER is an 8-bit readable/writable register that controls enabling and disabling of interrupt requests IRQ7 to IRQ0.

IER is initialized to H'00 by a reset and in hardware standby mode.

Bits 7 to 0—IRQ7 to IRQ0 Enable (IRQ7E to IRQ0E): These bits select whether IRQ7 to IRQ0 are enabled or disabled.

Bit n	Description	
0	IRQn interrupts disabled	(Initial value)
1	IRQn interrupts enabled	

(n = 7 to 0)

5.2.4 IRQ Sense Control Registers H and L (ISCRH, ISCLR)

ISCRH

Bit	:	15	14	13	12	11	10	9	8
		IRQ7SCB	IRQ7SCA	IRQ6SCB	IRQ6SCA	IRQ5SCB	IRQ5SCA	IRQ4SCB	IRQ4SCA
Initial value	:	0	0	0	0	0	0	0	0
R/W	:	R/W	R/W	R/W	R/W	R/W	R/W	R/W	R/W

ISCLR

Bit	:	7	6	5	4	3	2	1	0
		IRQ3SCB	IRQ3SCA	IRQ2SCB	IRQ2SCA	IRQ1SCB	IRQ1SCA	IRQ0SCB	IRQ0SCA
Initial value	:	0	0	0	0	0	0	0	0
R/W	:	R/W	R/W	R/W	R/W	R/W	R/W	R/W	R/W

ISCR (composed of ISCRH and ISCLR) is a 16-bit readable/writable register that selects rising edge, falling edge, or both edge detection, or level sensing, for the input at pins $\overline{\text{IRQ}}7$ to $\overline{\text{IRQ}}0$.

ISCR is initialized to H'0000 by a reset and in hardware standby mode.

Bits 15 to 0—IRQ7 Sense Control A and B (IRQ7SCA, IRQ7SCB) to IRQ0 Sense Control A and B (IRQ0SCA, IRQ0SCB)

Bits 15 to 0

IRQ7SCB to IRQ0SCB	IRQ7SCA to IRQ0SCA	Description
0	0	Interrupt request generated at $\overline{\text{IRQ}}7$ to $\overline{\text{IRQ}}0$ input low level (Initial value)
	1	Interrupt request generated at falling edge of $\overline{\text{IRQ}}7$ to $\overline{\text{IRQ}}0$ input
1	0	Interrupt request generated at rising edge of $\overline{\text{IRQ}}7$ to $\overline{\text{IRQ}}0$ input
	1	Interrupt request generated at both falling and rising edges of IRQ7 to IRQ0 input

5.2.5 IRQ Status Register (ISR)

Bit	:	7	6	5	4	3	2	1	0
		IRQ7F	IRQ6F	IRQ5F	IRQ4F	IRQ3F	IRQ2F	IRQ1F	IRQ0F
Initial value :		0	0	0	0	0	0	0	0
R/W	:	R/(W)*	R/(W)*	R/(W)*	R/(W)*	R/(W)*	R/(W)*	R/(W)*	R/(W)*

Note: * Only 0 can be written, to clear the flag.

ISR is an 8-bit readable/writable register that indicates the status of IRQ7 to IRQ0 interrupt requests.

ISR is initialized to H'00 by a reset and in hardware standby mode.

Bits 7 to 0—IRQ7 to IRQ0 flags (IRQ7F to IRQ0F): These bits indicate the status of IRQ7 to IRQ0 interrupt requests.

Bit n	IRQnF	Description
-------	-------	-------------

0		[Clearing conditions] (Initial value)
		<ul style="list-style-type: none"> • Cleared by reading IRQnF flag when IRQnF = 1, then writing 0 to IRQnF flag • When interrupt exception handling is executed when low-level detection is set (IRQnSCB = IRQnSCA = 0) and $\overline{\text{IRQn}}$ input is high • When IRQn interrupt exception handling is executed when falling, rising, or both-edge detection is set (IRQnSCB = 1 or IRQnSCA = 1) • When the DTC is activated by an IRQn interrupt, and the DISEL bit in MRB of the DTC is cleared to 0
1		[Setting conditions]
		<ul style="list-style-type: none"> • When $\overline{\text{IRQn}}$ input goes low when low-level detection is set (IRQnSCB = IRQnSCA = 0) • When a falling edge occurs in $\overline{\text{IRQn}}$ input when falling edge detection is set (IRQnSCB = 0, IRQnSCA = 1) • When a rising edge occurs in $\overline{\text{IRQn}}$ input when rising edge detection is set (IRQnSCB = 1, IRQnSCA = 0) • When a falling or rising edge occurs in $\overline{\text{IRQn}}$ input when both-edge detection is set (IRQnSCB = IRQnSCA = 1)
		(n = 7 to 0)

5.3 Interrupt Sources

Interrupt sources comprise external interrupts (NMI and IRQ7 to IRQ0) and internal interrupts (43 sources).

5.3.1 External Interrupts

There are nine external interrupts: NMI and IRQ7 to IRQ0. NMI and IRQ7 to IRQ0 can be used to restore the chip from software standby mode. (IRQ7 to IRQ3 can be designated for use as software standby mode clearing sources by setting the IRQ37S bit in SBYCR to 1.)

NMI Interrupt: NMI is the highest-priority interrupt, and is always accepted by the CPU regardless of the status of the CPU interrupt mask bits. The NMIEG bit in SYSCR can be used to select whether an interrupt is requested at a rising edge or a falling edge on the NMI pin.

The vector number for NMI interrupt exception handling is 7.

IRQ7 to IRQ0 Interrupts: Interrupts IRQ7 to IRQ0 are requested by an input signal at pins $\overline{\text{IRQ7}}$ to $\overline{\text{IRQ0}}$. Interrupts IRQ7 to IRQ0 have the following features:

- Using ISCR, it is possible to select whether an interrupt is generated by a low level, falling edge, rising edge, or both edges, at pins $\overline{\text{IRQ7}}$ to $\overline{\text{IRQ0}}$.
- Enabling or disabling of interrupt requests IRQ7 to IRQ0 can be selected with IER.
- The interrupt priority level can be set with IPR.
- The status of interrupt requests IRQ7 to IRQ0 is indicated in ISR. ISR flags can be cleared to 0 by software.

A block diagram of interrupts IRQ7 to IRQ0 is shown in figure 5.2.

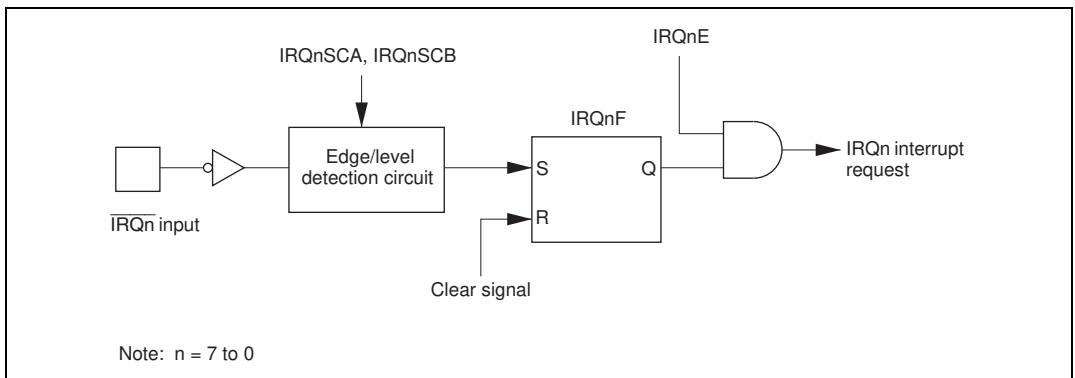

Figure 5.2 Block Diagram of Interrupts IRQ7 to IRQ0

Figure 5.3 shows the timing of setting IRQnF.

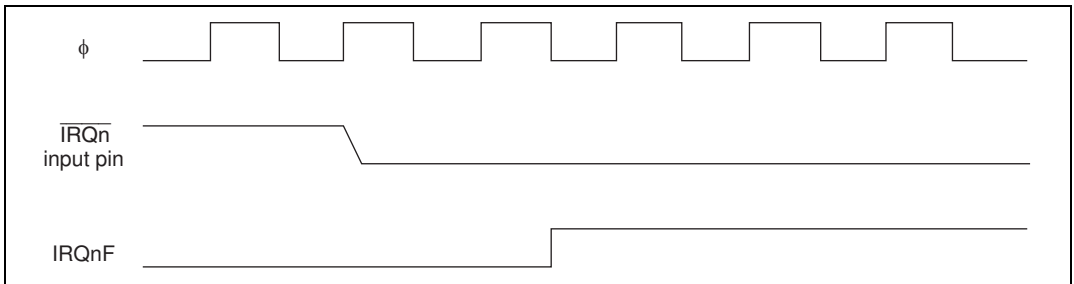

Figure 5.3 Timing of Setting IRQnF

The vector numbers for IRQ7 to IRQ0 interrupt exception handling are 23 to 16.

Detection of IRQ7 to IRQ0 interrupts does not depend on whether the relevant pin has been set for input or output. Therefore, when a pin is used as an external interrupt input pin, do not clear the corresponding DDR bit to 0 and use the pin as an I/O pin for another function.

5.3.2 Internal Interrupts

There are 43 sources for internal interrupts from on-chip supporting modules.

- For each on-chip supporting module there are flags that indicate the interrupt request status, and enable bits that select enabling or disabling of these interrupts. If both of these are set to 1 for a particular interrupt source, an interrupt request is issued to the interrupt controller.
- The interrupt priority level can be set by means of IPR.
- The DTC can be activated by a TPU, SCI, or other interrupt request. When the DTC is activated by an interrupt, the interrupt control mode and interrupt mask bits have no effect.

5.3.3 Interrupt Exception Vector Table

Table 5.4 shows interrupt exception handling sources, vector addresses, and interrupt priorities. For default priorities, the lower the vector number, the higher the priority. The DTC can also be activated by some interrupt sources.

Priorities among modules can be set by means of IPR. The situation when two or more modules are set to the same priority, and priorities within a module, are fixed as shown in table 5.4.

Table 5.4 Interrupt Sources, Vector Addresses, and Interrupt Priorities

Interrupt Source	Origin of Interrupt Source	Vector Number	Vector Address*	IPR	Priority	DTC Activation
Power-on reset		0	H'0000	—	↑ High	—
Reserved		1	H'0004			
Reserved for system use		2	H'0008			
		3	H'000C			
		4	H'0010			
Trace		5	H'0014			
Reserved for system use		6	H'0018			
NMI	External pin	7	H'001C			
Trap instruction (4 sources)		8	H'0020			
		9	H'0024			
		10	H'0028			
		11	H'002C			
Reserved for system use		12	H'0030			
		13	H'0034			
		14	H'0038			
		15	H'003C			
IRQ0	External pin	16	H'0040	IPRA6 to IPRA4		○
IRQ1		17	H'0044	IPRA2 to IPRA0		○
IRQ2		18	H'0048	IPRB6 to IPRB4		○
IRQ3		19	H'004C			○
IRQ4		20	H'0050	IPRB2 to IPRB0		○
IRQ5		21	H'0054			○
IRQ6		22	H'0058	IPRC6 to IPRC4		○
IRQ7		23	H'005C		Low	○

Interrupt Source	Origin of Interrupt Source	Vector Number	Vector Address*	IPR	Priority	DTC Activation	
SWDTEND (software-activated data transfer end)	DTC	24	H'0060	IPRC2 to IPRC0	↑ High	○	
WOVI (interval timer)	Watchdog timer	25	H'0064	IPRD6 to IPRD4		—	
Reserved	—	26	H'0068	IPRD2 to IPRD0		—	
Reserved	—	27	H'006C	IPRE6 to IPRE4		—	
ADI (A/D conversion end)	A/D	28	H'0070	IPRE2 to IPRE0		○	
Reserved	—	29	H'0074			—	
		30	H'0078				
		31	H'007C				
TGI0A (TGR0A input capture/compare match)	TPU channel 0	32	H'0080	IPRF6 to IPRF4		○	
TGI0B (TGR0B input capture/compare match)		33	H'0084			○	
TGI0C (TGR0C input capture/compare match)		34	H'0088			○	
TGI0D (TGR0D input capture/compare match)		35	H'008C			○	
TCI0V (overflow 0)		36	H'0090			—	
Reserved		—	37	H'0094			—
			38	H'0098			
	39		H'009C				
						Low	

Interrupt Source	Origin of Interrupt Source	Vector Number	Vector Address*	IPR	Priority	DTC Activation
TGI1A (TGR1A input capture/compare match)	TPU channel 1	40	H'00A0	IPRF2 to IPRF0	↑ High	○
TGI1B (TGR1B input capture/compare match)		41	H'00A4			○
TCI1V (overflow 1)		42	H'00A8			—
TCI1U (underflow 1)	43	H'00AC	—			
TGI2A (TGR2A input capture/compare match)	TPU channel 2	44	H'00B0	IPRG6 to IPRG4		↑ Low
TGI2B (TGR2B input capture/compare match)		45	H'00B4		○	
TCI2V (overflow 2)		46	H'00B8		—	
TCI2U (underflow 2)	47	H'00BC	—			
TGI3A (TGR3A input capture/compare match)	TPU channel 3	48	H'00C0	IPRG2 to IPRG0	↑ Low	
TGI3B (TGR3B input capture/compare match)		49	H'00C4			○
TGI3C (TGR3C input capture/compare match)		50	H'00C8			○
TGI3D (TGR3D input capture/compare match)		51	H'00CC			○
TCI3V (overflow 3)		52	H'00D0			—
Reserved	—	53	H'00D4		↑ Low	—
		54	H'00D8			—
		55	H'00DC			—

Interrupt Source	Origin of Interrupt Source	Vector Number	Vector Address*	IPR	Priority	DTC Activation
TGI4A (TGR4A input capture/compare match)	TPU channel 4	56	H'00E0	IPRH6 to IPRH4	High ↑	○
TGI4B (TGR4B input capture/compare match)		57	H'00E4			○
TCI4V (overflow 4)		58	H'00E8			—
TCI4U (underflow 4)		59	H'00EC			—
TGI5A (TGR5A input capture/compare match)	TPU channel 5	60	H'00F0	IPRH2 to IPRH0		○
TGI5B (TGR5B input capture/compare match)		61	H'00F4			○
TCI5V (overflow 5)		62	H'00F8			—
TCI5U (underflow 5)		63	H'00FC		—	
CMIA0 (compare match A)	8-bit timer channel 0	64	H'0100	IPRI6 to IPRI4	○	
CMIB0 (compare match B)		65	H'0104		○	
OVI0 (overflow 0)	—	66	H'0108	—	—	
Reserved	—	67	H'010C	—	—	
CMIA1 (compare match A)	8-bit timer channel 1	68	H'0110	IPRI2 to IPRI0	○	
CMIB1 (compare match B)		69	H'0114		○	
OVI1 (overflow 1)	—	70	H'0118	—	—	
Reserved	—	71	H'011C	—	Low	

Interrupt Source	Origin of Interrupt Source	Vector Number	Vector Address*	IPR	Priority	DTC Activation
Reserved	—	72	H'0120	IPRJ6 to IPRJ4	High	—
		73	H'0124			
		74	H'0128			
		75	H'012C			
		76	H'0130			
		77	H'0134			
		78	H'0138			
		79	H'013C			
		ERI0 (receive error 0)	SCI channel 0			
RX10 (receive-data-full 0)		81	H'0144			○
TX10 (transmit-data-empty 0)		82	H'0148			○
TEI0 (transmit end 0)		83	H'014C			—
ERI1 (receive error 1)	SCI channel 1	84	H'0150	IPRK6 to IPRK4		—
RX11 (receive-data-full 1)		85	H'0154			○
TX11 (transmit-data-empty 1)		86	H'0158			○
TEI1 (transmit end 1)		87	H'015C			—
Reserved	—	88	H'0160	IPRK2 to IPRK0	Low	—
		89	H'0164			
		90	H'0168			
		91	H'016C			

Note: * Lower 16 bits of the start address.

5.4 Interrupt Operation

5.4.1 Interrupt Control Modes and Interrupt Operation

Interrupt operations in the chip differ depending on the interrupt control mode.

NMI interrupts are accepted at all times except in the reset state and the hardware standby state. In the case of IRQ interrupts and on-chip supporting module interrupts, an enable bit is provided for each interrupt. Clearing an enable bit to 0 disables the corresponding interrupt request. Interrupt sources for which the enable bits are set to 1 are controlled by the interrupt controller.

Table 5.5 shows the interrupt control modes.

The interrupt controller performs interrupt control according to the interrupt control mode set by the INTM1 and INTM0 bits in SYSCR, the priorities set in IPR, and the masking state indicated by the I bit in the CPU's CCR, and bits I2 to I0 in EXR.

Table 5.5 Interrupt Control Modes

Interrupt Control Mode	SYSCR		Priority Setting Registers	Interrupt Mask Bits	Description
	INTM1	INTM0			
0	0	0	—	I	Interrupt mask control is performed by the I bit.
—	—	1	—	—	Setting prohibited
2	1	0	IPR	I2 to I0	8-level interrupt mask control is performed by bits I2 to I0. 8 priority levels can be set with IPR.
—	—	1	—	—	Setting prohibited

Figure 5.4 shows a block diagram of the priority decision circuit.

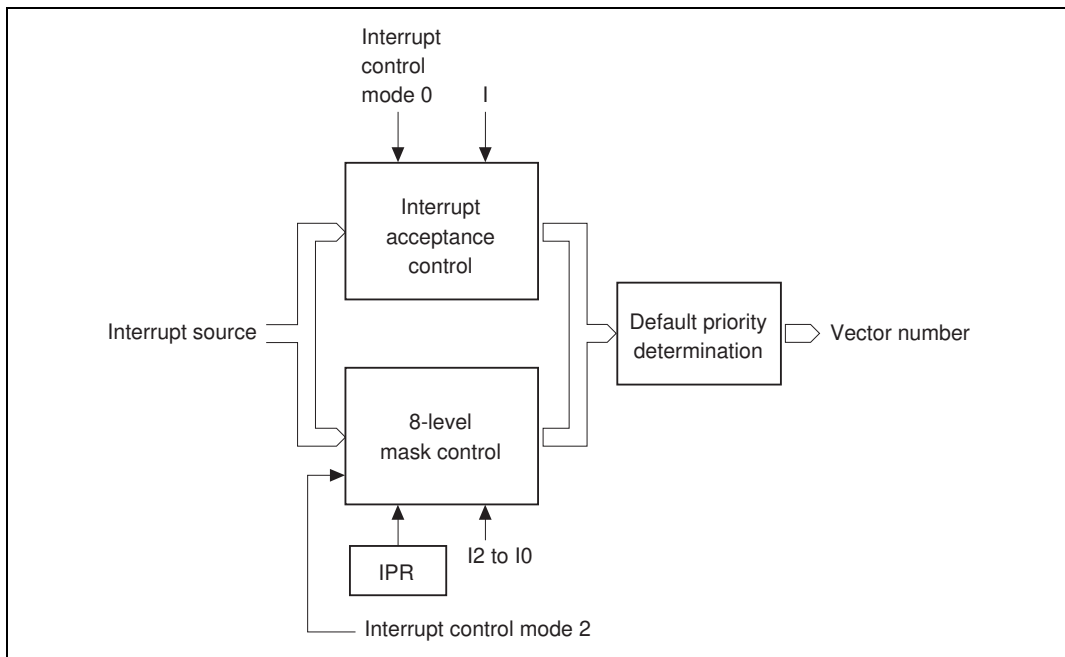

Figure 5.4 Block Diagram of Interrupt Control Operation

Interrupt Acceptance Control: In interrupt control mode 0, interrupt acceptance is controlled by the I bit in CCR.

Table 5.6 shows the interrupts selected in each interrupt control mode.

Table 5.6 Interrupts Selected in Each Interrupt Control Mode (1)

Interrupt Control Mode	Interrupt Mask Bits	
	I	Selected Interrupts
0	0	All interrupts
	1	NMI interrupts
2	*	All interrupts

* : Don't care

8-Level Control: In interrupt control mode 2, 8-level mask level determination is performed for the selected interrupts in interrupt acceptance control according to the interrupt priority level (IPR).

The interrupt source selected is the interrupt with the highest priority level, and whose priority level set in IPR is higher than the mask level.

Table 5.7 Interrupts Selected in Each Interrupt Control Mode (2)

Interrupt Control Mode	Selected Interrupts
0	All interrupts
2	Highest-priority-level (IPR) interrupt whose priority level is greater than the mask level (IPR > I2 to I0)

Default Priority Determination: When an interrupt is selected by 8-level control, its priority is determined and a vector number is generated.

If the same value is set for IPR, acceptance of multiple interrupts is enabled, and so only the interrupt source with the highest priority according to the preset default priorities is selected and has a vector number generated.

Interrupt sources with a lower priority than the accepted interrupt source are held pending.

Table 5.8 shows operations and control signal functions in each interrupt control mode.

Table 5.8 Operations and Control Signal Functions in Each Interrupt Control Mode

Interrupt Control Mode	Setting		Interrupt Acceptance Control		8-Level Control		Default Priority Determination	T (Trace)	
	INTM1	INTM0	I	I2 to I0	IPR				
0	0	0	○	IM	X	—	—*2	○	—
2	1	0	X	—*1	○	IM	PR	○	T

Legend:

○ : Interrupt operation control performed

X : No operation (All interrupts enabled)

IM : Used as interrupt mask bit

PR : Sets priority

— : Not used

Notes: 1. Set to 1 when interrupt is accepted.

2. Keep the initial setting.

5.4.2 Interrupt Control Mode 0

Enabling and disabling of IRQ interrupts and on-chip supporting module interrupts can be set by means of the I bit in the CPU's CCR. Interrupts are enabled when the I bit is cleared to 0, and disabled when set to 1.

Figure 5.5 shows a flowchart of the interrupt acceptance operation in this case.

- [1] If an interrupt source occurs when the corresponding interrupt enable bit is set to 1, an interrupt request is sent to the interrupt controller.
- [2] The I bit is then referenced. If the I bit is cleared to 0, the interrupt request is accepted. If the I bit is set to 1, only an NMI interrupt is accepted, and other interrupt requests are held pending.
- [3] Interrupt requests are sent to the interrupt controller, the highest-ranked interrupt according to the priority system is accepted, and other interrupt requests are held pending.
- [4] When an interrupt request is accepted, interrupt exception handling starts after execution of the current instruction has been completed.
- [5] The PC and CCR are saved to the stack area by interrupt exception handling. The PC saved on the stack shows the address of the first instruction to be executed after returning from the interrupt handling routine.
- [6] Next, the I bit in CCR is set to 1. This masks all interrupts except NMI.
- [7] A vector address is generated for the accepted interrupt, and execution of the interrupt handling routine starts at the address indicated by the contents of that vector address.

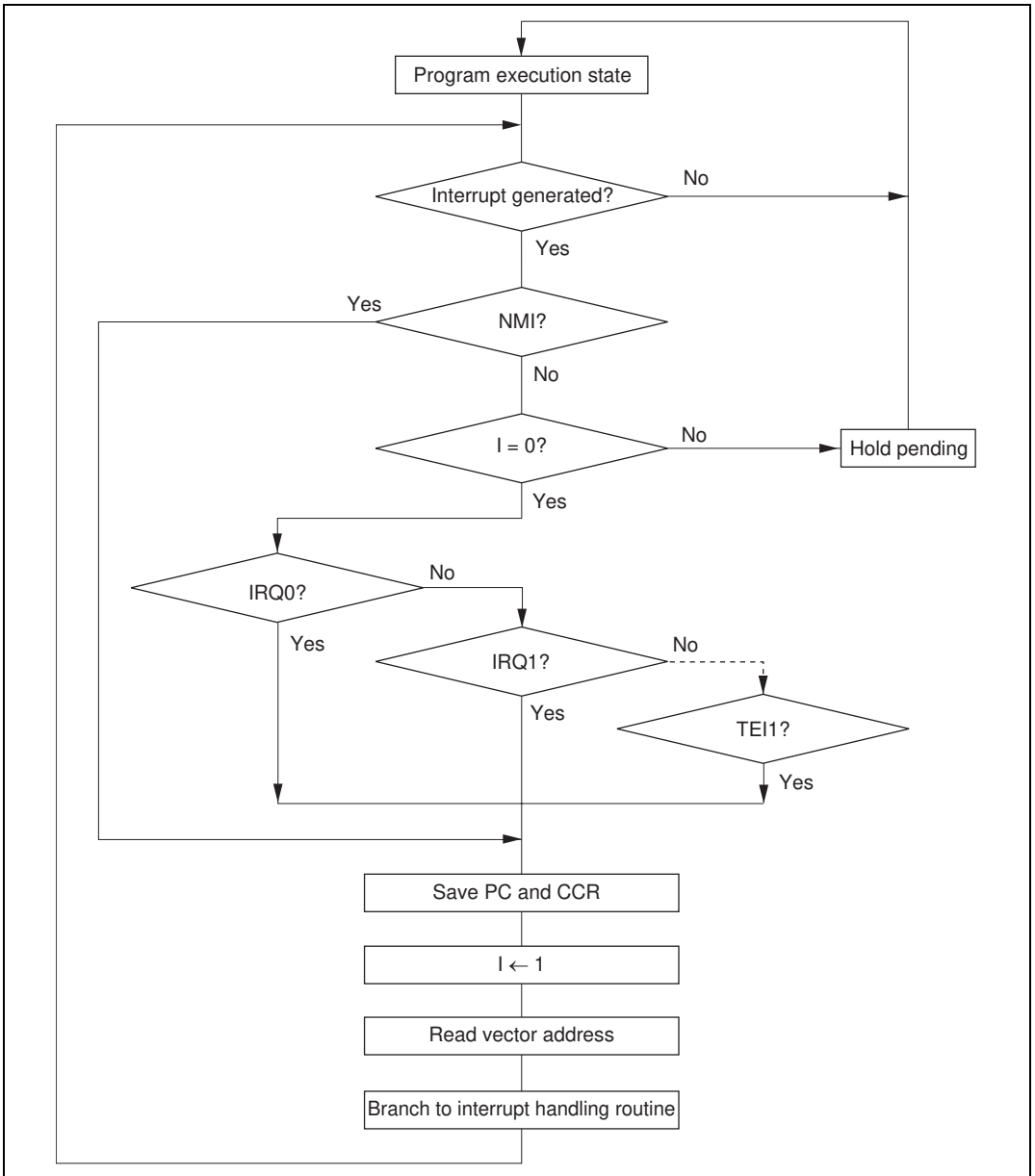

Figure 5.5 Flowchart of Procedure Up to Interrupt Acceptance in Interrupt Control Mode 0

5.4.3 Interrupt Control Mode 2

Eight-level masking is implemented for IRQ interrupts and on-chip supporting module interrupts by comparing the interrupt mask level set by bits I2 to I0 of EXR in the CPU with IPR.

Figure 5.6 shows a flowchart of the interrupt acceptance operation in this case.

- [1] If an interrupt source occurs when the corresponding interrupt enable bit is set to 1, an interrupt request is sent to the interrupt controller.
- [2] When interrupt requests are sent to the interrupt controller, the interrupt with the highest priority according to the interrupt priority levels set in IPR is selected, and lower-priority interrupt requests are held pending. If a number of interrupt requests with the same priority are generated at the same time, the interrupt request with the highest priority according to the priority system shown in table 5.4 is selected.
- [3] Next, the priority of the selected interrupt request is compared with the interrupt mask level set in EXR. An interrupt request with a priority no higher than the mask level set at that time is held pending, and only an interrupt request with a priority higher than the interrupt mask level is accepted.
- [4] When an interrupt request is accepted, interrupt exception handling starts after execution of the current instruction has been completed.
- [5] The PC, CCR, and EXR are saved to the stack area by interrupt exception handling. The PC saved on the stack shows the address of the first instruction to be executed after returning from the interrupt handling routine.
- [6] The T bit in EXR is cleared to 0. The interrupt mask level is rewritten with the priority level of the accepted interrupt.
If the accepted interrupt is NMI, the interrupt mask level is set to H'7.
- [7] A vector address is generated for the accepted interrupt, and execution of the interrupt handling routine starts at the address indicated by the contents of that vector address.

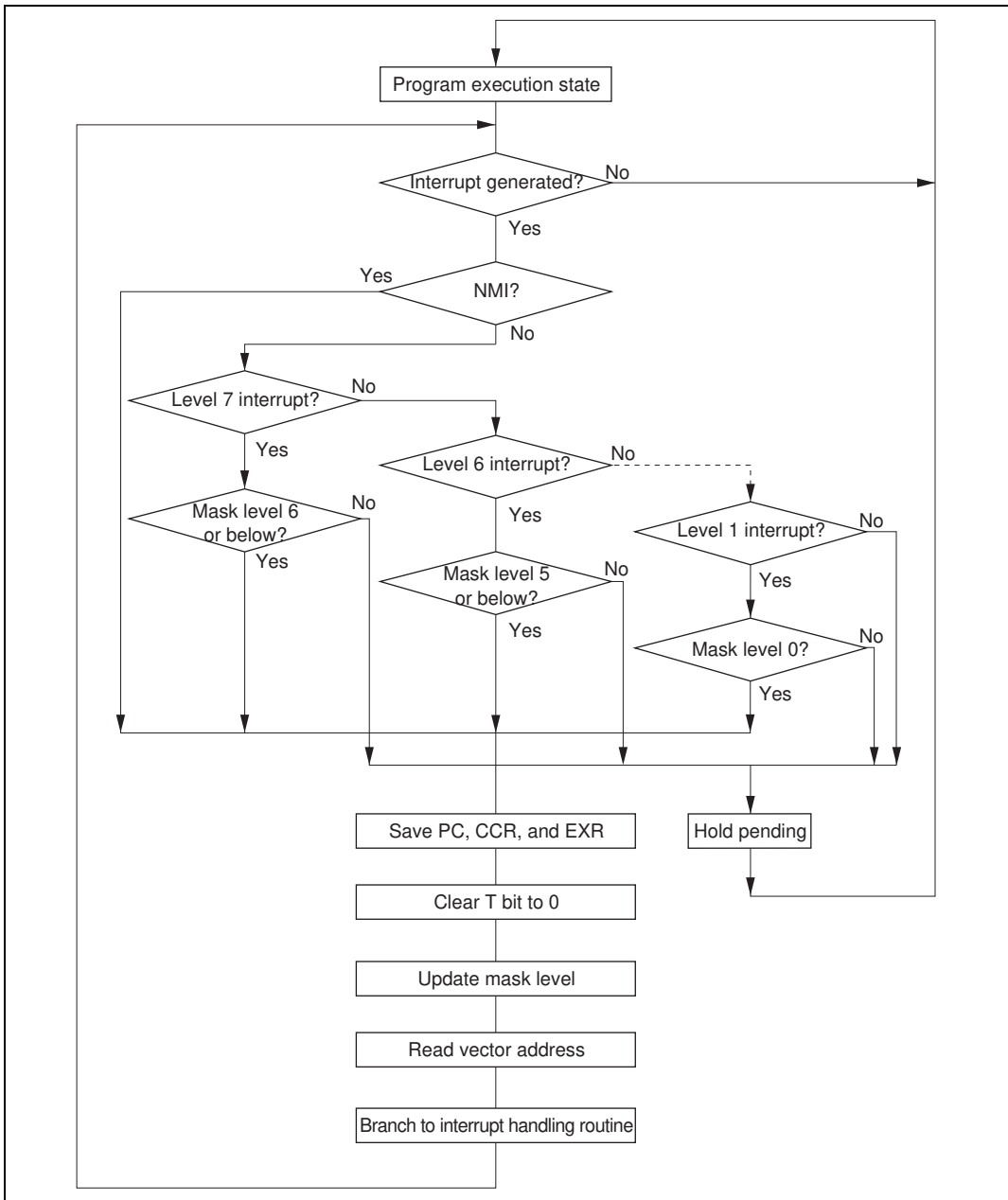

Figure 5.6 Flowchart of Procedure Up to Interrupt Acceptance in Interrupt Control Mode 2

5.4.4 Interrupt Exception Handling Sequence

Figure 5.7 shows the interrupt exception handling sequence. The example shown is for the case where interrupt control mode 0 is set in advanced mode, and the program area and stack area are in on-chip memory.

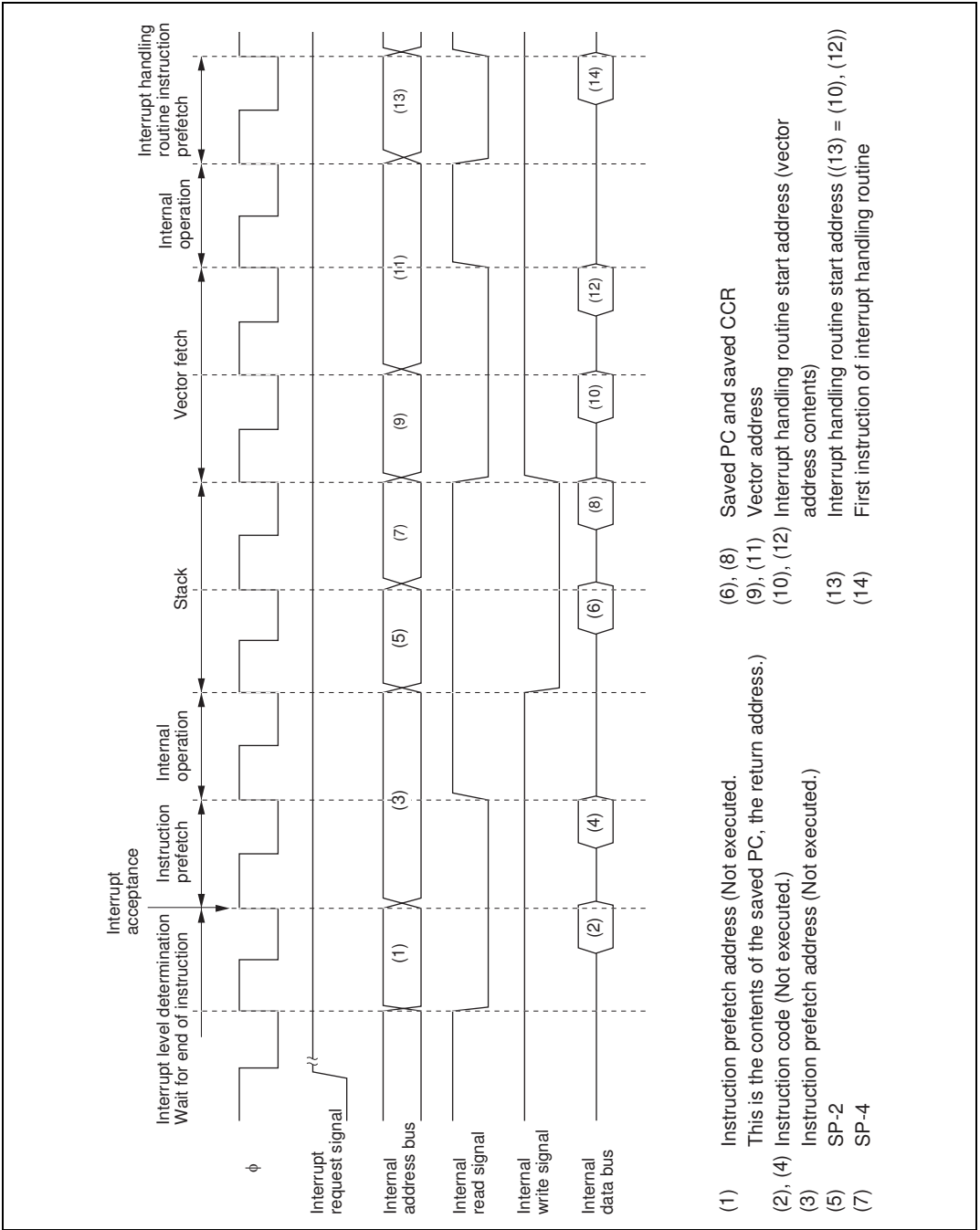

Figure 5.7 Interrupt Exception Handling

5.4.5 Interrupt Response Times

The chip is capable of fast word transfer instruction to on-chip memory, and the program area is provided in on-chip ROM and the stack area in on-chip RAM, enabling high-speed processing.

Table 5.9 shows interrupt response times—the interval between generation of an interrupt request and execution of the first instruction in the interrupt handling routine. The execution status symbols used in table 5.9 are explained in table 5.10.

Table 5.9 Interrupt Response Times

No.	Item	Advanced Mode	
		INTM1 = 0	INTM1 = 1
1	Interrupt priority determination* ¹	3	3
2	Number of wait states until executing instruction ends* ²	1 to (19+2·S _I)	1 to (19+2·S _I)
3	PC, CCR, EXR stack save	2·S _K	3·S _K
4	Vector fetch	2·S _I	2·S _I
5	Instruction fetch* ³	2·S _I	2·S _I
6	Internal processing* ⁴	2	2
Total (using on-chip memory)		12 to 32	13 to 33

Notes: 1. Two states in case of internal interrupt.

2. Refers to MULXS and DIVXS instructions.

3. Prefetch after interrupt acceptance and interrupt handling routine prefetch.

4. Internal processing after interrupt acceptance and internal processing after vector fetch.

Table 5.10 Number of States in Interrupt Handling Routine Execution

Symbol		Internal Memory	Object of Access			
			External Device			
			8-Bit Bus		16-Bit Bus	
		2-State Access	3-State Access	2-State Access	3-State Access	
Instruction fetch	S _I	1	4	6+2m	2	3+m
Branch address read	S _J					
Stack manipulation	S _K					

Legend:

m: Number of wait states in an external device access.

5.5 Usage Notes

5.5.1 Contention between Interrupt Generation and Disabling

When an interrupt enable bit is cleared to 0 to disable interrupts, the disabling becomes effective after execution of the instruction.

In other words, when an interrupt enable bit is cleared to 0 by an instruction such as BCLR or MOV, if an interrupt is generated during execution of the instruction, the interrupt concerned will still be enabled on completion of the instruction, and so interrupt exception handling for that interrupt will be executed on completion of the instruction. However, if there is an interrupt request of higher priority than that interrupt, interrupt exception handling will be executed for the higher-priority interrupt, and the lower-priority interrupt will be ignored.

The same also applies when an interrupt source flag is cleared.

Figure 5.8 shows an example in which the TGIEA bit in the TPU's TIER0 register is cleared to 0.

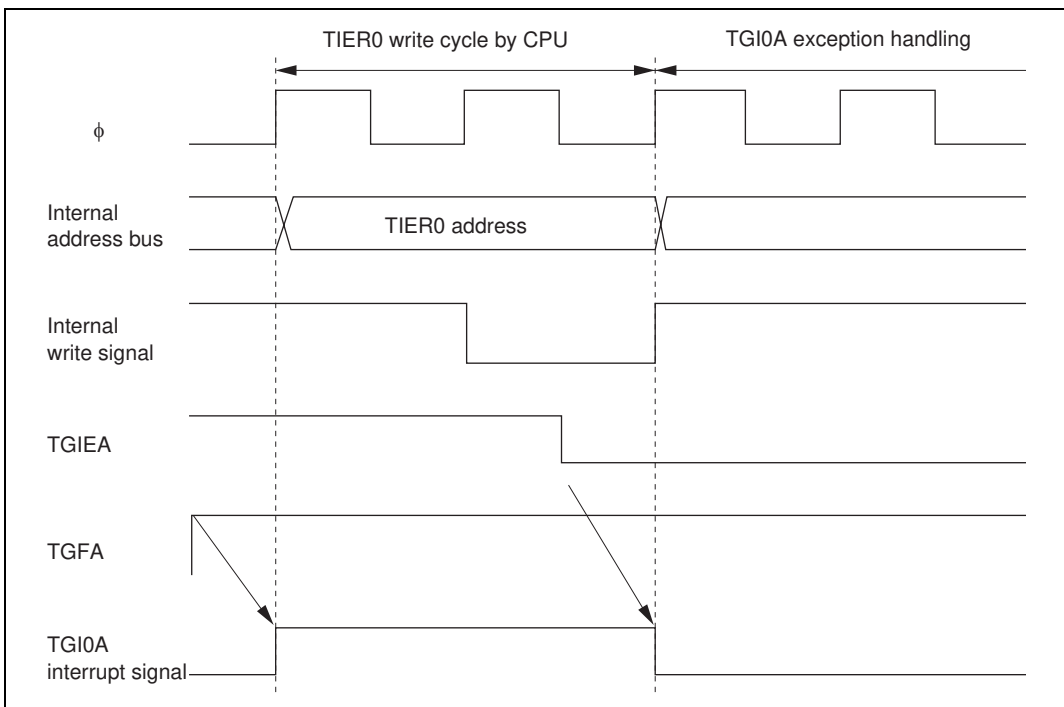

Figure 5.8 Contention between Interrupt Generation and Disabling

The above contention will not occur if an enable bit or interrupt source flag is cleared to 0 while the interrupt is masked.

5.5.2 Instructions that Disable Interrupts

Instructions that disable interrupts are LDC, ANDC, ORC, and XORC. After any of these instructions is executed, all interrupts including NMI are disabled and the next instruction is always executed. When the I bit is set by one of these instructions, the new value becomes valid two states after execution of the instruction ends.

5.5.3 Times when Interrupts are Disabled

There are times when interrupt acceptance is disabled by the interrupt controller.

The interrupt controller disables interrupt acceptance for a 3-state period after the CPU has updated the mask level with an LDC, ANDC, ORC, or XORC instruction.

5.5.4 Interrupts during Execution of EEPMOV Instruction

Interrupt operation differs between the EEPMOV.B instruction and the EEPMOV.W instruction.

With the EEPMOV.B instruction, an interrupt request (including NMI) issued during the transfer is not accepted until the move is completed.

With the EEPMOV.W instruction, if an interrupt request is issued during the transfer, interrupt exception handling starts at a break in the transfer cycle. The PC value saved on the stack in this case is the address of the next instruction.

Therefore, if an interrupt is generated during execution of an EEPMOV.W instruction, the following coding should be used.

```
L1:  EEPMOV.W
      MOV.W   R4, R4
      BNE    L1
```

5.6 DTC Activation by Interrupt

5.6.1 Overview

The DTC can be activated by an interrupt. In this case, the following options are available.

1. Interrupt request to CPU
2. Activation request to DTC
3. Selection of a number of the above

For details of interrupt requests that can be used with to activate the DTC, see section 7, Data Transfer Controller.

5.6.2 Block Diagram

Figure 5.9 shows a block diagram of the DTC and interrupt controller.

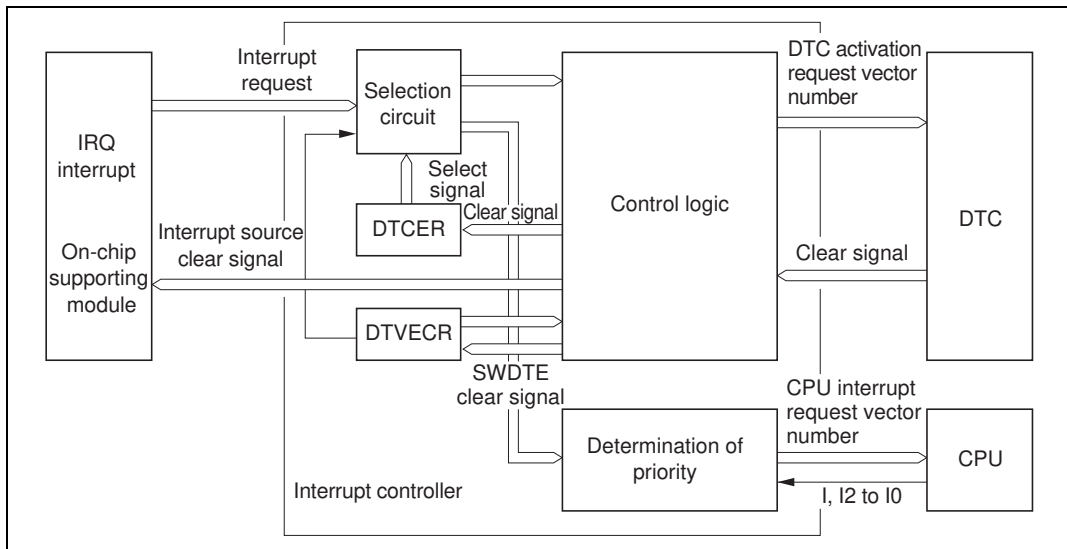

Figure 5.9 Interrupt Control for DTC

5.6.3 Operation

The interrupt controller has three main functions in DTC control.

Selection of Interrupt Source: For interrupt sources, it is possible to select DTC activation request or CPU interrupt request with the DTCE bit of DTCERA to DTCERE in the DTC.

After a DTC data transfer, the DTCE bit can be cleared to 0 and an interrupt request sent to the CPU in accordance with the specification of the DISEL bit of MRB in the DTC.

When the DTC has performed the specified number of data transfers and the transfer counter value is zero, the DTCE bit is cleared to 0 and an interrupt request is sent to the CPU after the DTC data transfer.

Determination of Priority: The DTC activation source is selected in accordance with the default priority order, and is not affected by mask or priority levels. See section 7.3.3, DTC Vector Table, for the respective priorities.

Operation Order: If the same interrupt is selected as a DTC activation source and a CPU interrupt source, the DTC data transfer is performed first, followed by CPU interrupt exception handling.

Table 5.11 summarizes interrupt source selection and interrupt source clearance control according to the settings of the DTCE bit of DTCERA to DTCERE, and the DISEL bit of MRB in the DTC.

Table 5.11 Interrupt Source Selection and Clearing Control

Settings		Interrupt Source Selection/Clearing Control	
DTC		DTC	CPU
DTCE	DISEL		
0	×	X	◎
1	0	◎	X
	1	○	◎

Legend:

- ◎ : The relevant interrupt is used. Interrupt source clearing is performed.
(The CPU should clear the source flag in the interrupt handling routine.)
- : The relevant interrupt is used. The interrupt source is not cleared.
- X : The relevant interrupt cannot be used.
- × : Don't care

Usage Note: SCI and A/D converter interrupt sources are cleared when the DTC reads or writes to the prescribed register, and are not dependent upon the DTA bit or DIESEL bit.

Section 6 Bus Controller

6.1 Overview

The chip has a built-in bus controller (BSC) that manages the external address space divided into eight areas. The bus specifications, such as bus width and number of access states, can be set independently for each area, enabling multiple memories to be connected easily.

The bus controller also has a bus arbitration function, and controls the operation of the internal bus masters: the CPU and data transfer controller (DTC).

6.1.1 Features

The features of the bus controller are listed below.

- Manages external address space in area units
 - In advanced mode, manages the external space as 8 areas of 2 Mbytes
 - Bus specifications can be set independently for each area
 - Burst ROM interfaces can be set
- Basic bus interface
 - Chip select ($\overline{CS0}$ to $\overline{CS7}$) can be output for areas 0 to 7
 - 8-bit access or 16-bit access can be selected for each area
 - 2-state access or 3-state access can be selected for each area
 - Program wait states can be inserted for each area
- Burst ROM interface
 - Burst ROM interface can be set for area 0
 - Choice of 1- or 2-state burst access
- Idle cycle insertion
 - An idle cycle can be inserted in case of an external read cycle between different areas
 - An idle cycle can be inserted when an external read cycle is immediately followed by an external write cycle
- Bus arbitration function
 - Includes a bus arbiter that arbitrates bus mastership among the CPU and DTC
- Other features
 - External bus release function

6.1.2 Block Diagram

Figure 6.1 shows a block diagram of the bus controller.

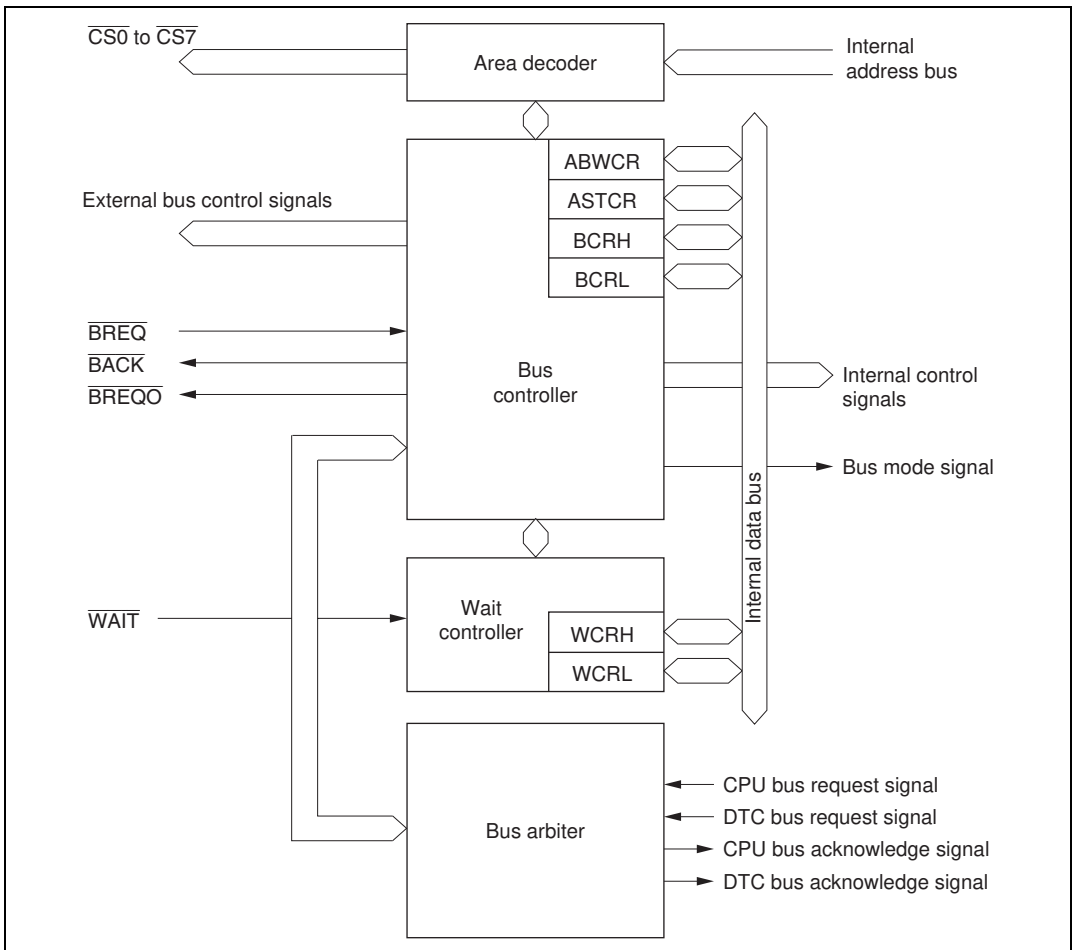

Figure 6.1 Block Diagram of Bus Controller

6.1.3 Pin Configuration

Table 6.1 summarizes the pins of the bus controller.

Table 6.1 Bus Controller Pins

Name	Symbol	I/O	Function
Address strobe	\overline{AS}	Output	Strobe signal indicating that address output on address bus is enabled.
Read	\overline{RD}	Output	Strobe signal indicating that external space is being read.
High write	\overline{HWR}	Output	Strobe signal indicating that external space is to be written, and upper half (D_{15} to D_8) of data bus is enabled.
Low write	\overline{LWR}	Output	Strobe signal indicating that external space is to be written, and lower half (D_7 to D_0) of data bus is enabled.
Chip select 0	$\overline{CS0}$	Output	Strobe signal indicating that area 0 is selected.
Chip select 1	$\overline{CS1}$	Output	Strobe signal indicating that area 1 is selected.
Chip select 2	$\overline{CS2}$	Output	Strobe signal indicating that area 2 is selected.
Chip select 3	$\overline{CS3}$	Output	Strobe signal indicating that area 3 is selected.
Chip select 4	$\overline{CS4}$	Output	Strobe signal indicating that area 4 is selected.
Chip select 5	$\overline{CS5}$	Output	Strobe signal indicating that area 5 is selected.
Chip select 6	$\overline{CS6}$	Output	Strobe signal indicating that area 6 is selected.
Chip select 7	$\overline{CS7}$	Output	Strobe signal indicating that area 7 is selected.
Wait	\overline{WAIT}	Input	Wait request signal when accessing external 3-state access space.
Bus request	\overline{BREQ}	Input	Request signal that releases bus to external device.
Bus request acknowledge	\overline{BACK}	Output	Acknowledge signal indicating that bus has been released.
Bus request output	\overline{BREQO}	Output	External bus request signal used when internal bus master accesses external space when external bus is released.

6.1.4 Register Configuration

Table 6.2 summarizes the registers of the bus controller.

Table 6.2 Bus Controller Registers

Name	Abbreviation	R/W	Initial Value	
			Reset	Address ^{*1}
Bus width control register	ABWCR	R/W	H'FF/H'00 ^{*2}	H'FED0
Access state control register	ASTCR	R/W	H'FF	H'FED1
Wait control register H	WCRH	R/W	H'FF	H'FED2
Wait control register L	WCRL	R/W	H'FF	H'FED3
Bus control register H	BCRH	R/W	H'D0	H'FED4
Bus control register L	BCRL	R/W	H'3C	H'FED5

Notes: 1. Lower 16 bits of the address.

2. Determined by the MCU operating mode.

6.2 Register Descriptions

6.2.1 Bus Width Control Register (ABWCR)

Bit	:	7	6	5	4	3	2	1	0
		ABW7	ABW6	ABW5	ABW4	ABW3	ABW2	ABW1	ABW0
Modes 5 to 7									
Initial value :		1	1	1	1	1	1	1	1
R/W	:	R/W	R/W	R/W	R/W	R/W	R/W	R/W	R/W
Mode 4									
Initial value :		0	0	0	0	0	0	0	0
R/W	:	R/W	R/W	R/W	R/W	R/W	R/W	R/W	R/W

ABWCR is an 8-bit readable/writable register that designates each area for either 8-bit access or 16-bit access.

ABWCR sets the data bus width for the external memory space. The bus width for on-chip memory and internal I/O registers is fixed regardless of the settings in ABWCR.

After a reset and in hardware standby mode, ABWCR is initialized to H'FF in modes 5 to 7,* and to H'00 in mode 4. It is not initialized in software standby mode.

Note: *Modes 6 and 7 are not provided in the ROMless version.

Bits 7 to 0—Area 7 to 0 Bus Width Control (ABW7 to ABW0): These bits select whether the corresponding area is to be designated for 8-bit access or 16-bit access.

Bit n ABWn	Description
0	Area n is designated for 16-bit access
1	Area n is designated for 8-bit access

(n = 7 to 0)

6.2.2 Access State Control Register (ASTCR)

Bit	:	7	6	5	4	3	2	1	0
		AST7	AST6	AST5	AST4	AST3	AST2	AST1	AST0
Initial value :		1	1	1	1	1	1	1	1
R/W	:	R/W	R/W	R/W	R/W	R/W	R/W	R/W	R/W

ASTCR is an 8-bit readable/writable register that designates each area as either a 2-state access space or a 3-state access space.

ASTCR sets the number of access states for the external memory space. The number of access states for on-chip memory and internal I/O registers is fixed regardless of the settings in ASTCR.

ASTCR is initialized to H'FF by a reset and in hardware standby mode. It is not initialized in software standby mode.

Bits 7 to 0—Area 7 to 0 Access State Control (AST7 to AST0): These bits select whether the corresponding area is to be designated as a 2-state access space or a 3-state access space.

Wait state insertion is enabled or disabled at the same time.

Bit n ASTn	Description	
0	Area n is designated for 2-state access Wait state insertion in area n external space is disabled	
1	Area n is designated for 3-state access Wait state insertion in area n external space is enabled	(Initial value)

(n = 7 to 0)

6.2.3 Wait Control Registers H and L (WCRH, WCRL)

WCRH and WCRL are 8-bit readable/writable registers that select the number of program wait states for each area.

Program waits are not inserted in the case of on-chip memory or internal I/O registers.

WCRH and WCRL are initialized to H'FF by a reset and in hardware standby mode. They are not initialized in software standby mode.

WCRH

Bit	:	7	6	5	4	3	2	1	0								
		<table border="1"> <tr> <td>W71</td> <td>W70</td> <td>W61</td> <td>W60</td> <td>W51</td> <td>W50</td> <td>W41</td> <td>W40</td> </tr> </table>								W71	W70	W61	W60	W51	W50	W41	W40
W71	W70	W61	W60	W51	W50	W41	W40										
Initial value :		1	1	1	1	1	1	1	1								
R/W	:	R/W	R/W	R/W	R/W	R/W	R/W	R/W	R/W								

Bits 7 and 6—Area 7 Wait Control 1 and 0 (W71, W70): These bits select the number of program wait states when area 7 in external space is accessed while the AST7 bit in ASTCR is set to 1.

Bit 7 W71	Bit 6 W70	Description
0	0	Program wait not inserted when external space area 7 is accessed
	1	1 program wait state inserted when external space area 7 is accessed
1	0	2 program wait states inserted when external space area 7 is accessed
	1	3 program wait states inserted when external space area 7 is accessed (Initial value)

Bits 5 and 4—Area 6 Wait Control 1 and 0 (W61, W60): These bits select the number of program wait states when area 6 in external space is accessed while the AST6 bit in ASTCR is set to 1.

Bit 5 W61	Bit 4 W60	Description
0	0	Program wait not inserted when external space area 6 is accessed
	1	1 program wait state inserted when external space area 6 is accessed
1	0	2 program wait states inserted when external space area 6 is accessed
	1	3 program wait states inserted when external space area 6 is accessed (Initial value)

Bits 3 and 2—Area 5 Wait Control 1 and 0 (W51, W50): These bits select the number of program wait states when area 5 in external space is accessed while the AST5 bit in ASTCR is set to 1.

Bit 3 W51	Bit 2 W50	Description
0	0	Program wait not inserted when external space area 5 is accessed
	1	1 program wait state inserted when external space area 5 is accessed
1	0	2 program wait states inserted when external space area 5 is accessed
	1	3 program wait states inserted when external space area 5 is accessed (Initial value)

Bits 1 and 0—Area 4 Wait Control 1 and 0 (W41, W40): These bits select the number of program wait states when area 4 in external space is accessed while the AST4 bit in ASTCR is set to 1.

Bit 1 W41	Bit 0 W40	Description
0	0	Program wait not inserted when external space area 4 is accessed
	1	1 program wait state inserted when external space area 4 is accessed
1	0	2 program wait states inserted when external space area 4 is accessed
	1	3 program wait states inserted when external space area 4 is accessed (Initial value)

WCRL

Bit	:	7	6	5	4	3	2	1	0								
		W31		W30		W21		W20		W11		W10		W01		W00	
Initial value :		1	1	1	1	1	1	1	1	1	1	1	1	1	1	1	1
R/W	:	R/W	R/W	R/W	R/W	R/W	R/W	R/W	R/W	R/W	R/W	R/W	R/W	R/W	R/W	R/W	R/W

Bits 7 and 6—Area 3 Wait Control 1 and 0 (W31, W30): These bits select the number of program wait states when area 3 in external space is accessed while the AST3 bit in ASTCR is set to 1.

Bit 7 W31	Bit 6 W30	Description
0	0	Program wait not inserted when external space area 3 is accessed
	1	1 program wait state inserted when external space area 3 is accessed
1	0	2 program wait states inserted when external space area 3 is accessed
	1	3 program wait states inserted when external space area 3 is accessed (Initial value)

Bits 5 and 4—Area 2 Wait Control 1 and 0 (W21, W20): These bits select the number of program wait states when area 2 in external space is accessed while the AST2 bit in ASTCR is set to 1.

Bit 5 W21	Bit 4 W20	Description
0	0	Program wait not inserted when external space area 2 is accessed
	1	1 program wait state inserted when external space area 2 is accessed
1	0	2 program wait states inserted when external space area 2 is accessed
	1	3 program wait states inserted when external space area 2 is accessed (Initial value)

Bits 3 and 2—Area 1 Wait Control 1 and 0 (W11, W10): These bits select the number of program wait states when area 1 in external space is accessed while the AST1 bit in ASTCR is set to 1.

Bit 3 W11	Bit 2 W10	Description
0	0	Program wait not inserted when external space area 1 is accessed
	1	1 program wait state inserted when external space area 1 is accessed
1	0	2 program wait states inserted when external space area 1 is accessed
	1	3 program wait states inserted when external space area 1 is accessed (Initial value)

Bits 1 and 0—Area 0 Wait Control 1 and 0 (W01, W00): These bits select the number of program wait states when area 0 in external space is accessed while the AST0 bit in ASTCR is set to 1.

Bit 1 W01	Bit 0 W00	Description
0	0	Program wait not inserted when external space area 0 is accessed
	1	1 program wait state inserted when external space area 0 is accessed
1	0	2 program wait states inserted when external space area 0 is accessed
	1	3 program wait states inserted when external space area 0 is accessed (Initial value)

6.2.4 Bus Control Register H (BCRH)

Bit	:	7	6	5	4	3	2	1	0
		ICIS1	ICIS0	BRSTRM	BRSTS1	BRSTS0	—	—	—
Initial value	:	1	1	0	1	0	0	0	0
R/W	:	R/W	R/W	R/W	R/W	R/W	R/W	R/W	R/W

BCRH is an 8-bit readable/writable register that selects enabling or disabling of idle cycle insertion, and the memory interface for area 0.

BCRH is initialized to H'D0 by a reset and in hardware standby mode. It is not initialized in software standby mode.

Bit 7—Idle Cycle Insert 1 (ICIS1): Selects whether or not one idle cycle state is to be inserted between bus cycles when successive external read cycles are performed in different areas.

Bit 7

ICIS1	Description
0	Idle cycle not inserted in case of successive external read cycles in different areas
1	Idle cycle inserted in case of successive external read cycles in different areas (Initial value)

Bit 6—Idle Cycle Insert 0 (ICIS0): Selects whether or not one idle cycle state is to be inserted between bus cycles when successive external read and external write cycles are performed .

Bit 6

ICIS0	Description
0	Idle cycle not inserted in case of successive external read and external write cycles
1	Idle cycle inserted in case of successive external read and external write cycles (Initial value)

Bit 5—Burst ROM Enable (BRSTRM): Selects whether area 0 is used as a burst ROM interface area.

Bit 5

BRSTRM	Description
0	Area 0 is basic bus interface area (Initial value)
1	Area 0 is burst ROM interface area

Bit 4—Burst Cycle Select 1 (BRSTS1): Selects the number of burst cycles for the burst ROM interface.

Bit 4

BRSTS1	Description
0	Burst cycle comprises 1 state
1	Burst cycle comprises 2 states (Initial value)

Bit 3—Burst Cycle Select 0 (BRSTS0): Selects the number of words that can be accessed in a burst ROM interface burst access.

Bit 3**BRSTS0 Description**

0	Max. 4 words in burst access	(Initial value)
1	Max. 8 words in burst access	

Bits 2 to 0—Reserved: Only 0 should be written to these bits.

6.2.5 Bus Control Register L (BCRL)

Bit	:	7	6	5	4	3	2	1	0
		BRLE	BREQOE	EAE	—	—	—	—	WAITE
Initial value :		0	0	1	1	1	1	0	0
R/W :		R/W	R/W	R/W	R/W	R/W	R/W	R/W	R/W

BCRL is an 8-bit readable/writable register that performs selection of the external bus-released state protocol, selection of the area division unit, and enabling or disabling of $\overline{\text{WAIT}}$ pin input.

BCRL is initialized to H'3C by a reset and in hardware standby mode. It is not initialized in software standby mode.

Bit 7—Bus Release Enable (BRLE): Enables or disables external bus release.

Bit 7**BRLE Description**

0	External bus release is disabled. $\overline{\text{BREQ}}$, $\overline{\text{BACK}}$, and $\overline{\text{BREQO}}$ pins can be used as I/O ports	(Initial value)
1	External bus release is enabled	

Bit 6—BREQO Pin Enable (BREQOE): Outputs a signal that requests the external bus master to drop the bus request signal ($\overline{\text{BREQ}}$) in the external bus release state, when an internal bus master performs an external space access.

Bit 6

BREQOE	Description
0	$\overline{\text{BREQO}}$ output disabled. $\overline{\text{BREQO}}$ pin can be used as I/O port (Initial value)
1	$\overline{\text{BREQO}}$ output enabled

Bit 5—External Address Enable (EAE): Selects whether addresses H'010000 to H'03FFFF*² are to be internal addresses or external addresses.

Bit 5 EAE	Description		
	H8S/2319, H8S/2319C, H8S/2318, H8S/2315, H8S/2314	H8S/2317(S)* ³	H8S/2316S
0	On-chip ROM	Addresses H'010000 to H'01FFFF are on-chip ROM and addresses H'020000 to H'03FFFF are reserved area* ¹	Reserved area* ¹
1	Addresses H'010000 to H'03FFFF* ² are external addresses in external expanded mode or reserved area* ¹ in single-chip mode (Initial value)		

Notes: 1. Do not access a reserved area.

2. H'010000 to H'03FFFF in the H8S/2318.

H'010000 to H'05FFFF in the H8S/2315 and H8S/2314.

H'010000 to H'07FFFF in the H8S/2319 and H8S/2319C.

3. H8S/2317S in mask ROM version.

Bits 4 to 2—Reserved: Only 1 should be written to these bits.

Bit 1—Reserved: Only 0 should be written to this bit.

Bit 0—WAIT Pin Enable (WAITE): Selects enabling or disabling of wait input by the $\overline{\text{WAIT}}$ pin.

Bit 0

WAITE	Description
0	Wait input by $\overline{\text{WAIT}}$ pin disabled. $\overline{\text{WAIT}}$ pin can be used as I/O port (Initial value)
1	Wait input by $\overline{\text{WAIT}}$ pin enabled

6.3 Overview of Bus Control

6.3.1 Area Partitioning

In advanced mode, the bus controller partitions the 16-Mbyte address space into eight areas, 0 to 7, in 2-Mbyte units, and performs bus control for external space in area units. Figure 6.2 shows an outline of the area partitioning.

Chip select signals ($\overline{CS0}$ to $\overline{CS7}$) can be output for each area.

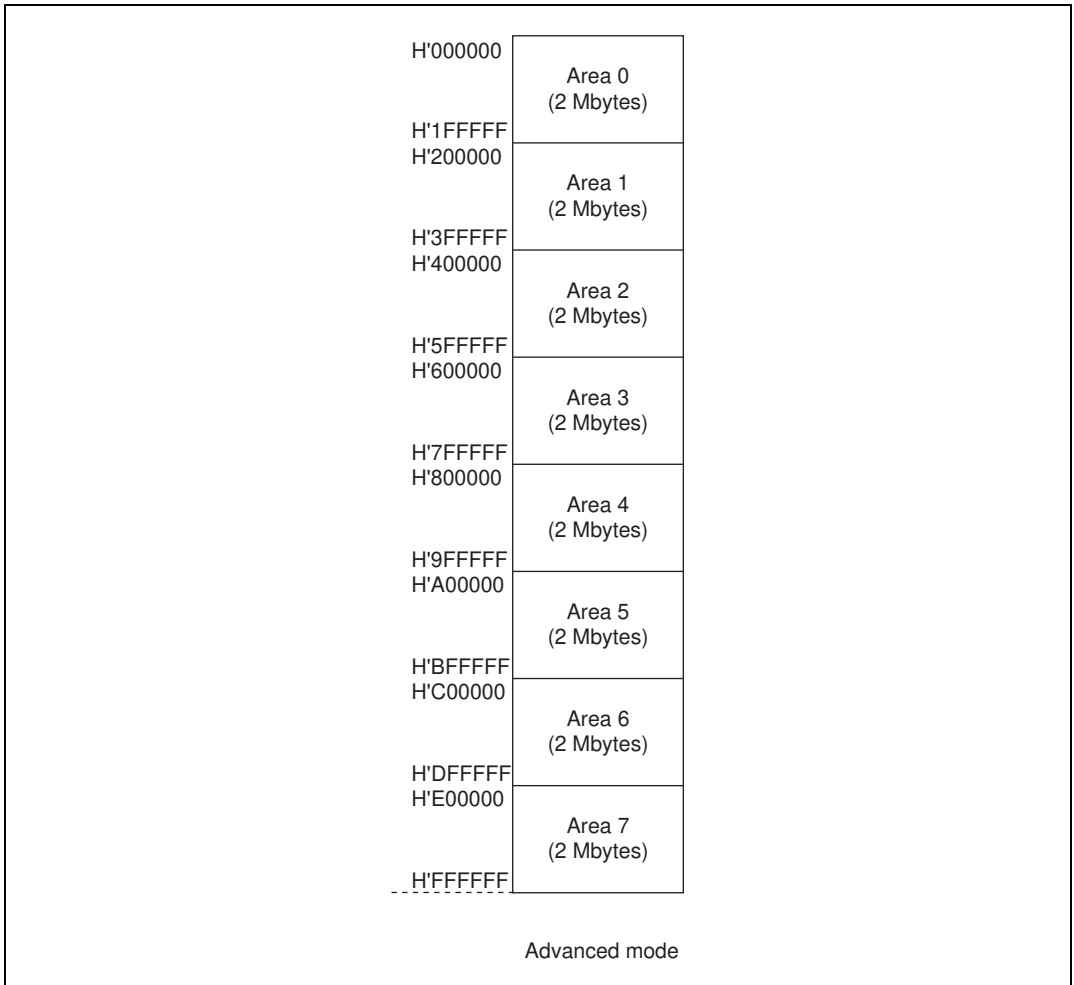

Figure 6.2 Overview of Area Partitioning

6.3.2 Bus Specifications

The external space bus specifications consist of three elements: bus width, number of access states, and number of program wait states.

The bus width and number of access states for on-chip memory and internal I/O registers are fixed, and are not affected by the bus controller.

Bus Width: A bus width of 8 or 16 bits can be selected with ABWCR. An area for which an 8-bit bus is selected functions as an 8-bit access space, and an area for which a 16-bit bus is selected functions as a 16-bit access space.

If all areas are designated for 8-bit access, 8-bit bus mode is set; if any area is designated for 16-bit access, 16-bit bus mode is set. When the burst ROM interface is designated, 16-bit bus mode is always set.

Number of Access States: Two or three access states can be selected with ASTCR. An area for which 2-state access is selected functions as a 2-state access space, and an area for which 3-state access is selected functions as a 3-state access space.

With the burst ROM interface, the number of access states may be determined without regard to ASTCR.

When 2-state access space is designated, wait insertion is disabled.

Number of Program Wait States: When 3-state access space is designated by ASTCR, the number of program wait states to be inserted automatically is selected with WCRH and WCRL. From 0 to 3 program wait states can be selected.

Table 6.3 shows the bus specifications for each basic bus interface area.

Table 6.3 Bus Specifications for Each Area (Basic Bus Interface)

ABWCR ABWn	ASTCR ASTn	WCRH, WCRL		Bus Specifications (Basic Bus Interface)		
		Wn1	Wn0	Bus Width	Access States	Program Wait States
0	0	—	—	16	2	0
		0	0			
	1	1	1		3	0
		0	2			
		1	3			
1	0	—	—	8	2	0
		0	0			
	1	1	1		3	0
		0	1			
		1	2			
		1	3			

6.3.3 Memory Interfaces

The chip's memory interfaces comprise a basic bus interface that allows direct connection of ROM, SRAM, and so on; and a burst ROM interface that allows direct connection of burst ROM. The interface can be selected independently for each area.

An area for which the basic bus interface is designated functions as normal space, and an area for which the burst ROM interface is designated functions as burst ROM space.

6.3.4 Advanced Mode

The initial state of each area is basic bus interface, 3-state access space. The initial bus width is selected according to the operating mode. The bus specifications described here cover basic items only, and the sections on each memory interface (sections 6.4, Basic Bus Interface, 6.5, Burst ROM Interface) should be referred to for further details.

Area 0: Area 0 includes on-chip ROM*, and in ROM-disabled expansion mode, all of area 0 is external space. In the ROM-enabled expansion mode, the space excluding on-chip ROM* is external space.

Note: * Applies to mask ROM versions only.

When area 0 external space is accessed, the $\overline{CS0}$ signal can be output.

Either basic bus interface or burst ROM interface can be selected for area 0.

Areas 1 to 6: In external expansion mode, all of area 1 to 6 is external space.

When area 1 to 6 external space is accessed, the $\overline{CS1}$ to $\overline{CS6}$ pin signals respectively can be output.

Only the basic bus interface can be used for areas 1 to 6.

Area 7: Area 7 includes the on-chip RAM and internal I/O registers. In external expansion mode, the space excluding the on-chip RAM and internal I/O registers is external space. The on-chip RAM is enabled when the RAME bit in the system control register (SYSCR) is set to 1; when the RAME bit is cleared to 0, the on-chip RAM is disabled and the corresponding space becomes external space.

When area 7 external space is accessed, the $\overline{CS7}$ signal can be output.

Only the basic bus interface can be used for the area 7.

6.3.5 Chip Select Signals

The chip can output chip select signals ($\overline{CS0}$ to $\overline{CS7}$) to areas 0 to 7, the signal being driven low when the corresponding external space area is accessed.

Figure 6.3 shows an example of \overline{CSn} ($n = 0$ to 7) output timing.

Enabling or disabling of the \overline{CSn} signal is performed by setting the data direction register (DDR), CS167 Enable (CS167E), CS25 Enable, CSS17, CSS36, PF1CS5S, PF0CS4S for the port corresponding to the particular \overline{CSn} pin.

In ROM-disabled expansion mode, the $\overline{CS0}$ pin is placed in the output state after a power-on reset. Pins $\overline{CS1}$ to $\overline{CS7}$ are placed in the input state after a power-on reset, and so the corresponding control registers should be set when outputting signals $\overline{CS1}$ to $\overline{CS7}$.

In the ROM-enabled expansion mode, pins $\overline{CS0}$ to $\overline{CS7}$ are all placed in the input state after a power-on reset, and so the corresponding control registers should be set when outputting signals $\overline{CS0}$ to $\overline{CS7}$.

For details, see section 8, I/O Ports.

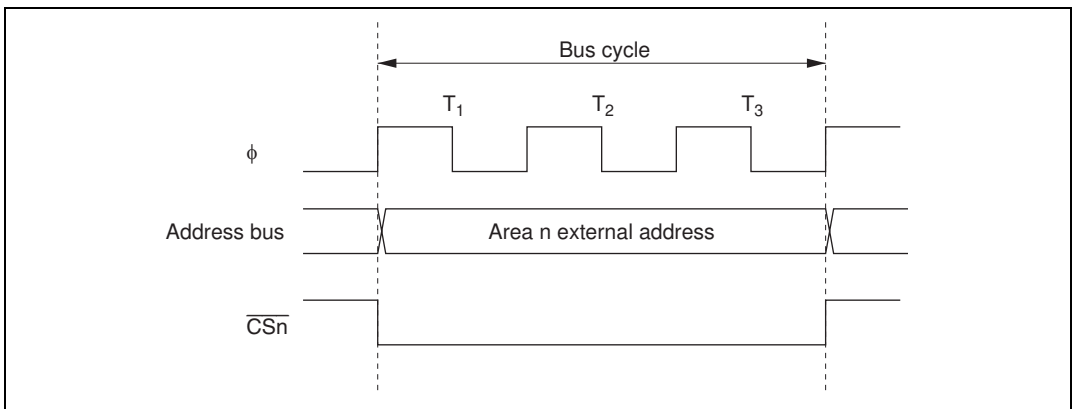

Figure 6.3 \overline{CSn} Signal Output Timing ($n = 0$ to 7)

6.4 Basic Bus Interface

6.4.1 Overview

The basic bus interface enables direct connection of ROM, SRAM, and so on.

The bus specifications can be selected with ABWCR, ASTCR, WCRH, and WCRL (see table 6.3).

6.4.2 Data Size and Data Alignment

Data sizes for the CPU and other internal bus masters are byte, word, and longword. The bus controller has a data alignment function, and when accessing external space, controls whether the upper data bus (D_{15} to D_8) or lower data bus (D_7 to D_0) is used according to the bus specifications for the area being accessed (8-bit access space or 16-bit access space) and the data size.

8-Bit Access Space: Figure 6.4 illustrates data alignment control for the 8-bit access space. With the 8-bit access space, the upper data bus (D_{15} to D_8) is always used for accesses. The amount of data that can be accessed at one time is one byte: a word transfer instruction is performed as two byte accesses, and a longword transfer instruction, as four byte accesses.

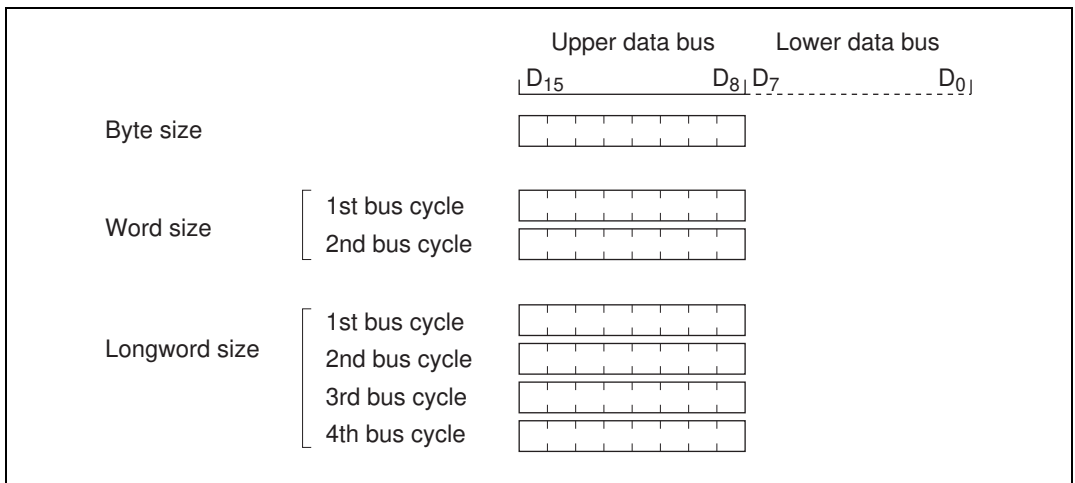

Figure 6.4 Access Sizes and Data Alignment Control (8-Bit Access Space)

16-Bit Access Space: Figure 6.5 illustrates data alignment control for the 16-bit access space. With the 16-bit access space, the upper data bus (D_{15} to D_8) and lower data bus (D_7 to D_0) are used for accesses. The amount of data that can be accessed at one time is one byte or one word, and a longword transfer instruction is executed as two word transfer instructions.

In byte access, whether the upper or lower data bus is used is determined by whether the address is even or odd. The upper data bus is used for an even address, and the lower data bus for an odd address.

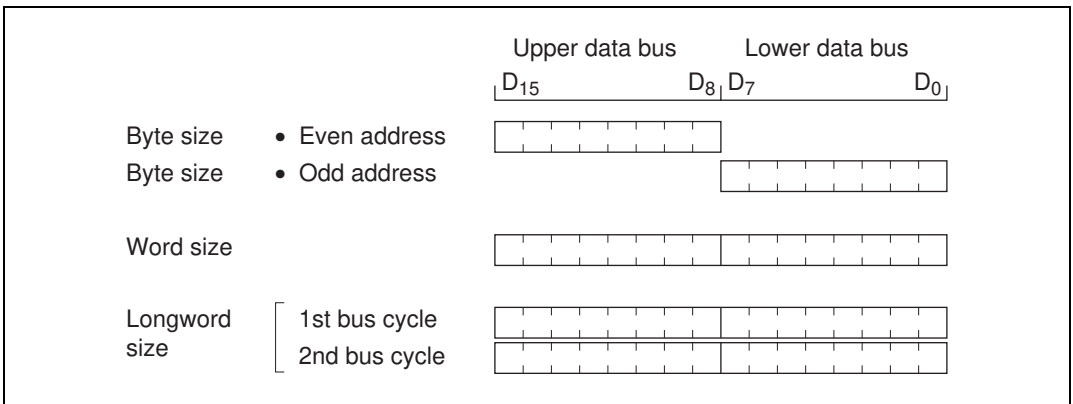

Figure 6.5 Access Sizes and Data Alignment Control (16-Bit Access Space)

6.4.3 Valid Strobes

Table 6.4 shows the data buses used and valid strobes for the access spaces.

In a read, the \overline{RD} signal is valid without discrimination between the upper and lower halves of the data bus.

In a write, the \overline{HWR} signal is valid for the upper half of the data bus, and the \overline{LWR} signal for the lower half.

Table 6.4 Data Buses Used and Valid Strobes

Area	Access Size	Read/Write	Address	Valid Strobe	Upper Data Bus (D ₁₅ to D ₈)	Lower Data Bus (D ₇ to D ₀)
8-bit access space	Byte	Read	—	\overline{RD}	Valid	Invalid
		Write	—	\overline{HWR}		Hi-Z
16-bit access space	Byte	Read	Even	\overline{RD}	Valid	Invalid
			Odd		Invalid	Valid
	Write	Even	\overline{HWR}	Valid	Hi-Z	
		Odd	\overline{LWR}	Hi-Z	Valid	
Word	Read	—	\overline{RD}	Valid	Valid	
		Write	—	$\overline{HWR}, \overline{LWR}$	Valid	Valid

Notes: Hi-Z: High impedance

Invalid: Input state; input value is ignored.

6.4.4 Basic Timing

8-Bit 2-State Access Space: Figure 6.6 shows the bus timing for an 8-bit 2-state access space. When an 8-bit access space is accessed, the upper half (D_{15} to D_8) of the data bus is used.

The \overline{LWR} pin is fixed high. Wait states cannot be inserted.

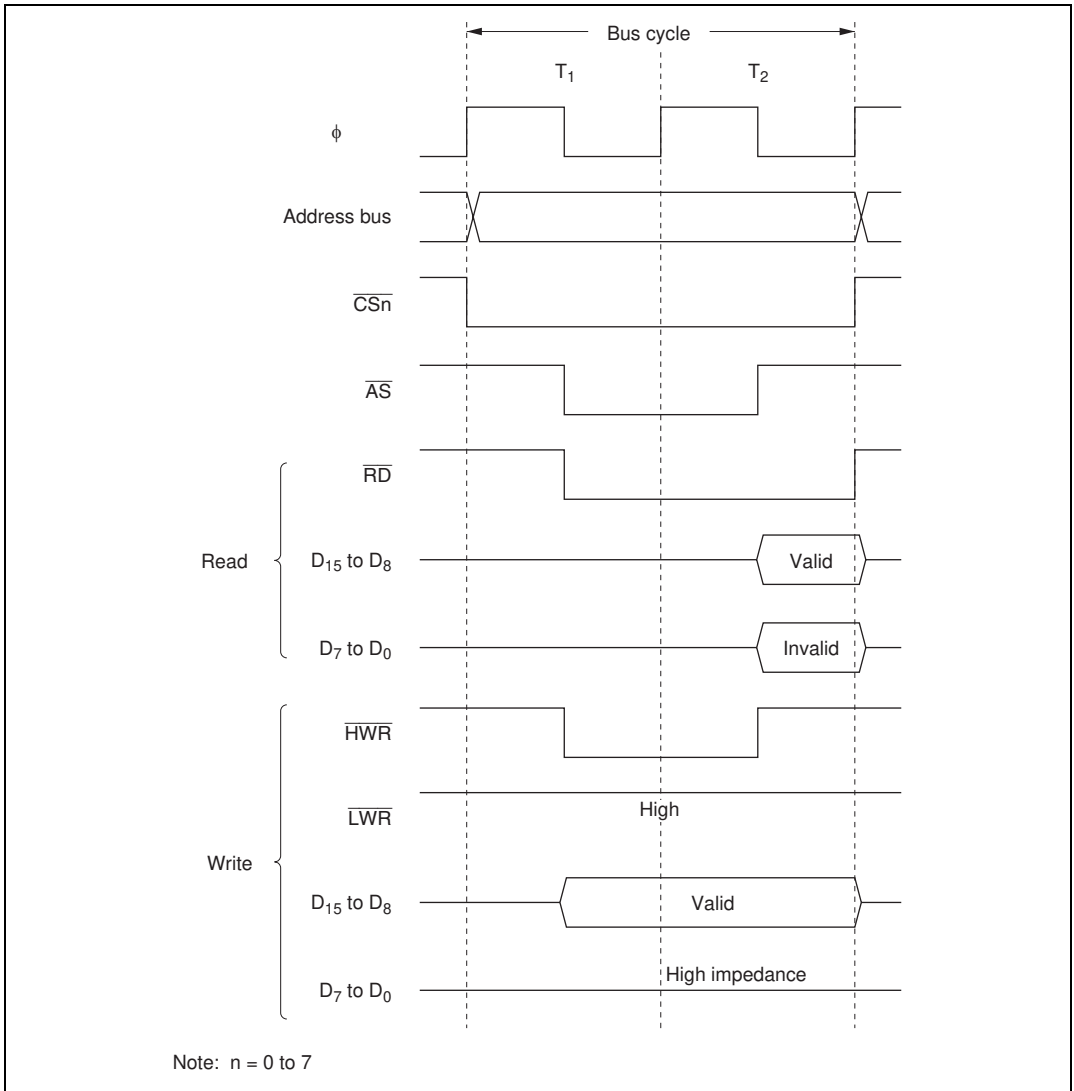

Figure 6.6 Bus Timing for 8-Bit 2-State Access Space

8-Bit 3-State Access Space: Figure 6.7 shows the bus timing for an 8-bit 3-state access space. When an 8-bit access space is accessed, the upper half (D_{15} to D_8) of the data bus is used.

The \overline{LWR} pin is fixed high. Wait states can be inserted.

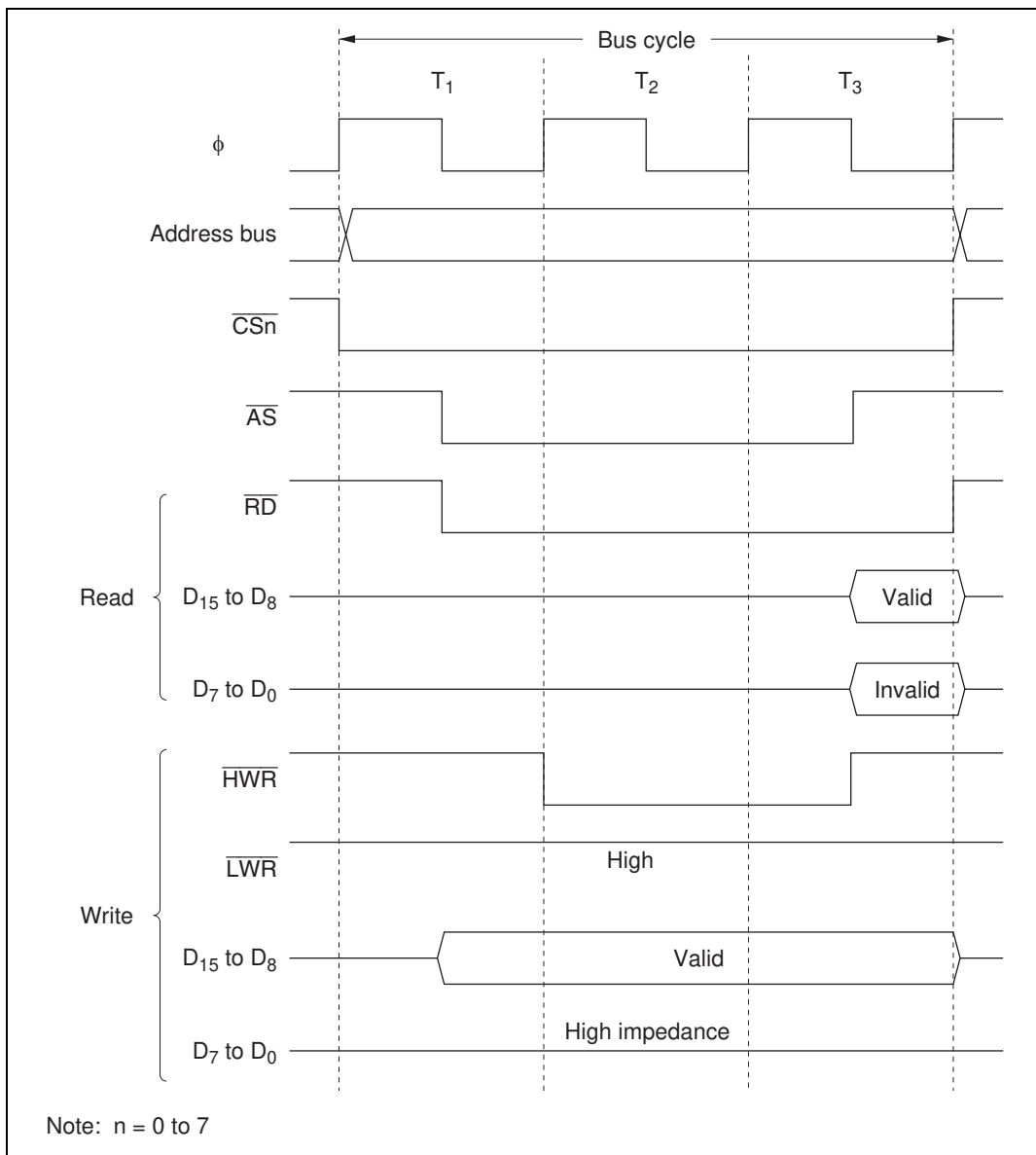

Figure 6.7 Bus Timing for 8-Bit 3-State Access Space

16-Bit 2-State Access Space: Figures 6.8 to 6.10 show bus timings for a 16-bit 2-state access space. When a 16-bit access space is accessed, the upper half (D_{15} to D_8) of the data bus is used for the even address, and the lower half (D_7 to D_0) for the odd address.

Wait states cannot be inserted.

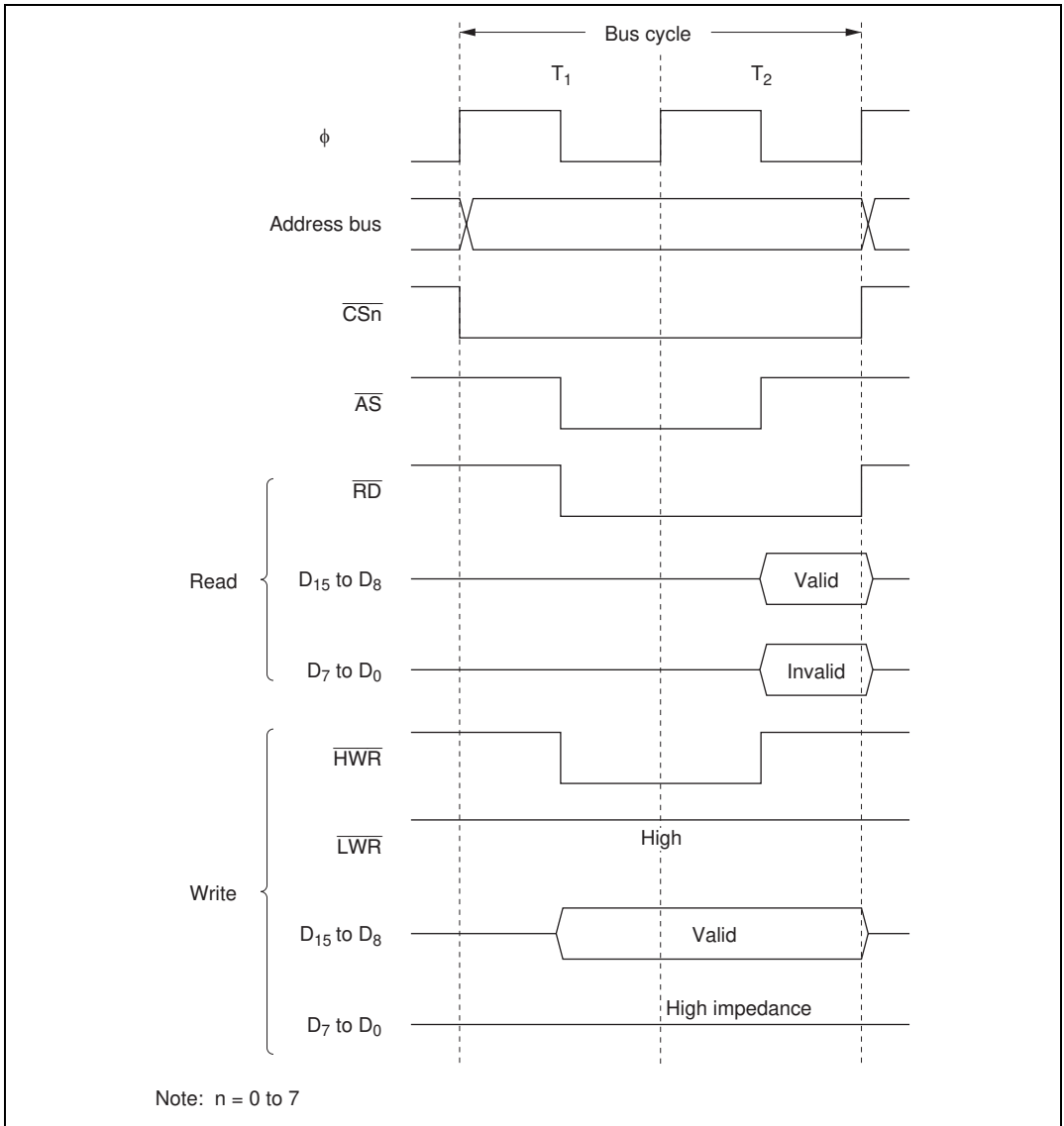

Figure 6.8 Bus Timing for 16-Bit 2-State Access Space (1) (Even Address Byte Access)

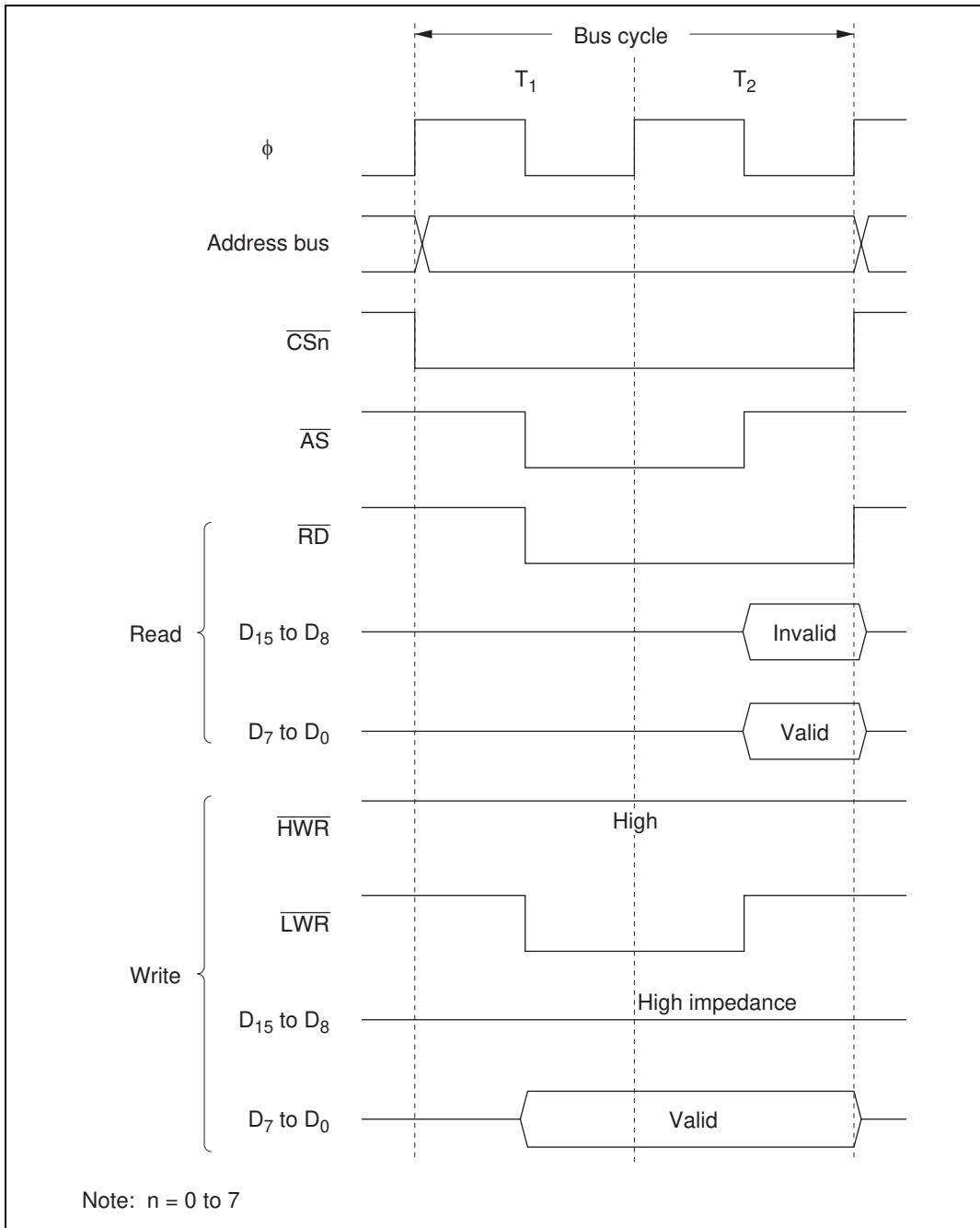

Figure 6.9 Bus Timing for 16-Bit 2-State Access Space (2) (Odd Address Byte Access)

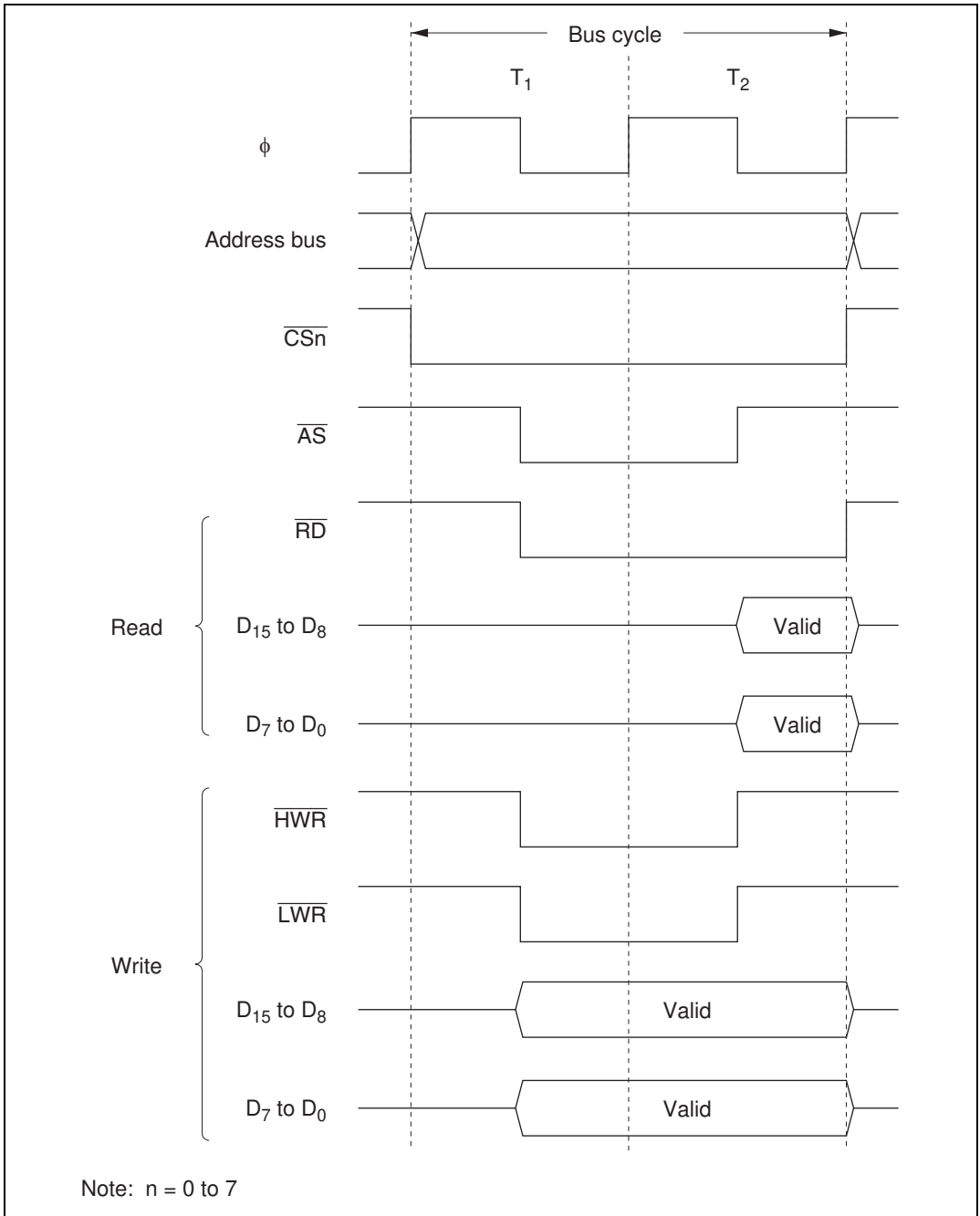

Figure 6.10 Bus Timing for 16-Bit 2-State Access Space (3) (Word Access)

16-Bit 3-State Access Space: Figures 6.11 to 6.13 show bus timings for a 16-bit 3-state access space. When a 16-bit access space is accessed, the upper half (D_{15} to D_8) of the data bus is used for the even address, and the lower half (D_7 to D_0) for the odd address.

Wait states can be inserted.

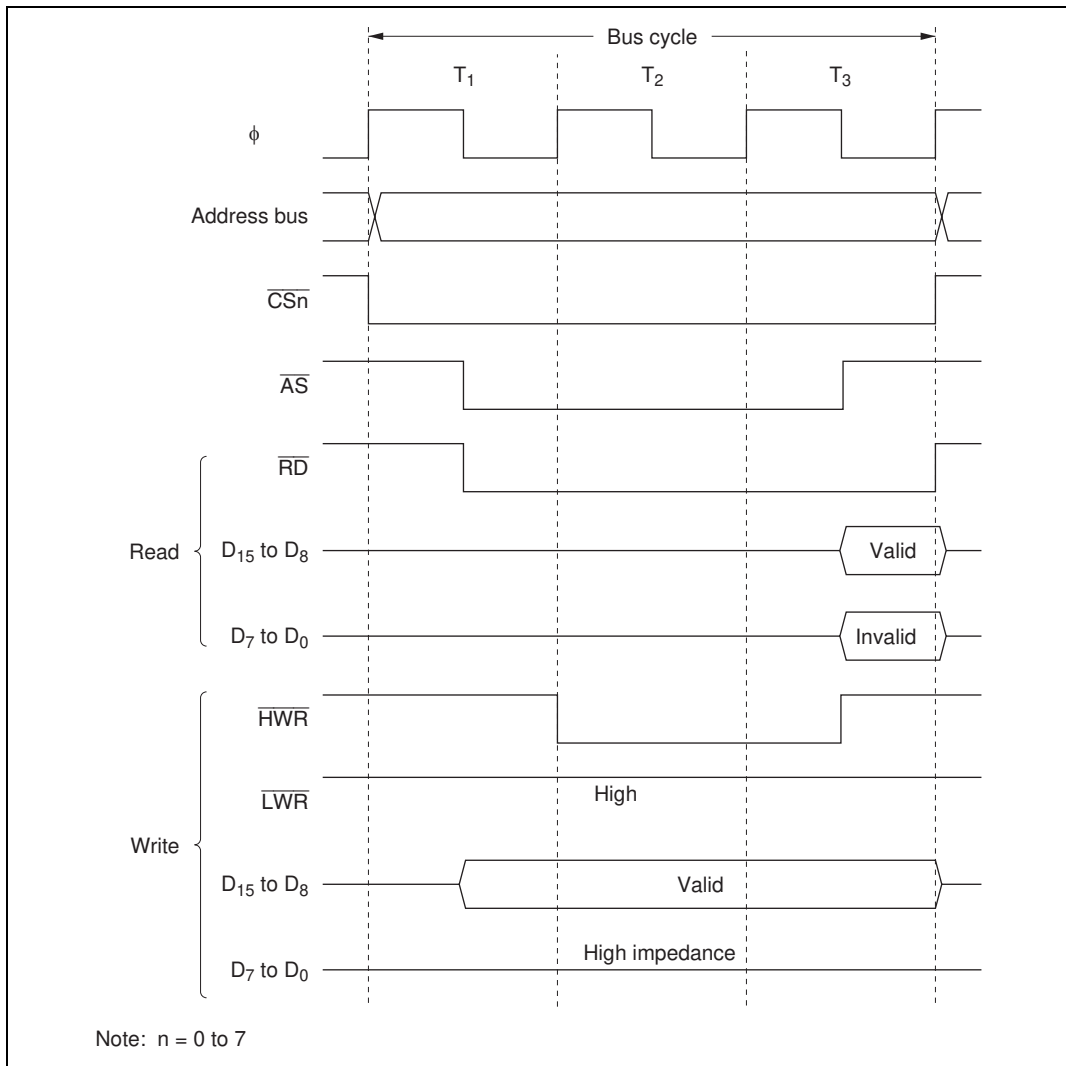

Figure 6.11 Bus Timing for 16-Bit 3-State Access Space (1) (Even Address Byte Access)

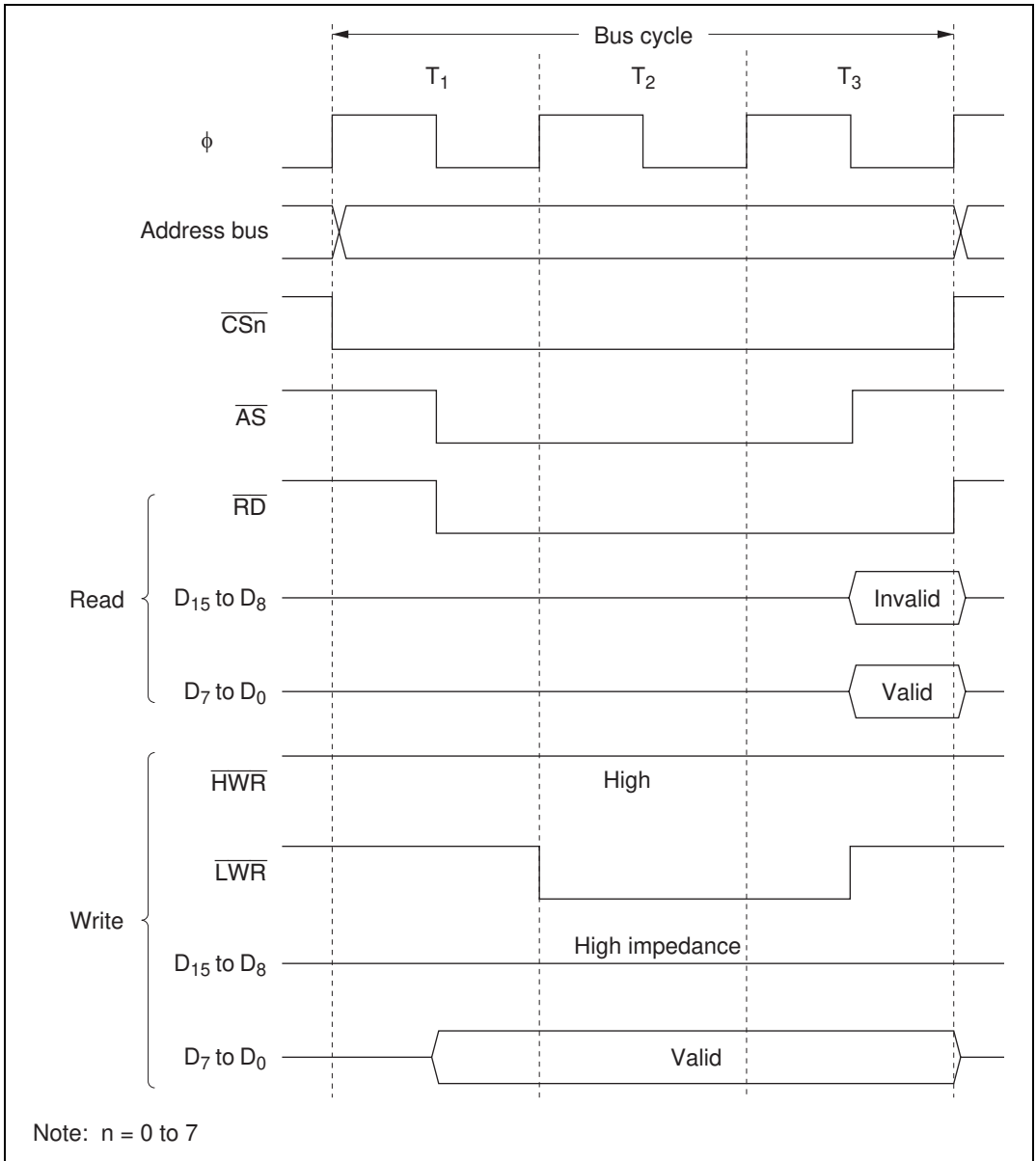

Figure 6.12 Bus Timing for 16-Bit 3-State Access Space (2) (Odd Address Byte Access)

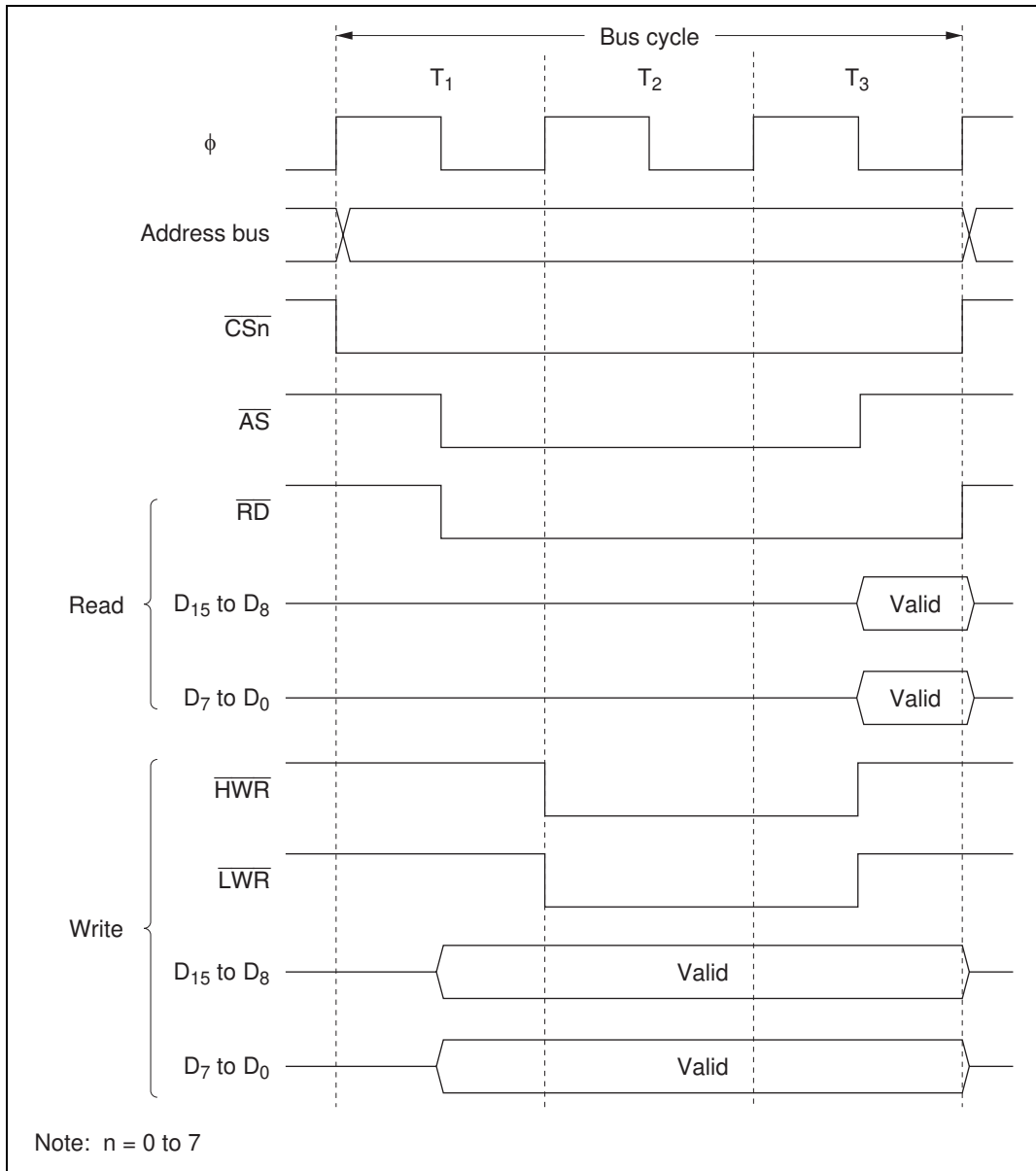

Figure 6.13 Bus Timing for 16-Bit 3-State Access Space (3) (Word Access)

6.4.5 Wait Control

When accessing external space, the H8S/2319 Group can extend the bus cycle by inserting one or more wait states (T_w). There are two ways of inserting wait states: program wait insertion and pin wait insertion using the $\overline{\text{WAIT}}$ pin.

Program Wait Insertion: From 0 to 3 wait states can be inserted automatically between the T_2 state and T_3 state on an individual area basis in 3-state access space, according to the settings of WCRH and WCRL.

Pin Wait Insertion: Setting the WAITE bit in BCRL to 1 enables wait insertion by means of the $\overline{\text{WAIT}}$ pin. When external space is accessed in this state, program wait insertion is first carried out according to the settings in WCRH and WCRL. Then, if the $\overline{\text{WAIT}}$ pin is low at the falling edge of ϕ in the last T_2 or T_w state, a T_w state is inserted. If the $\overline{\text{WAIT}}$ pin is held low, T_w states are inserted until it goes high.

This is useful when inserting four or more T_w states, or when changing the number of T_w states for different external devices.

The WAITE bit setting applies to all areas.

Figure 6.14 shows an example of wait state insertion timing.

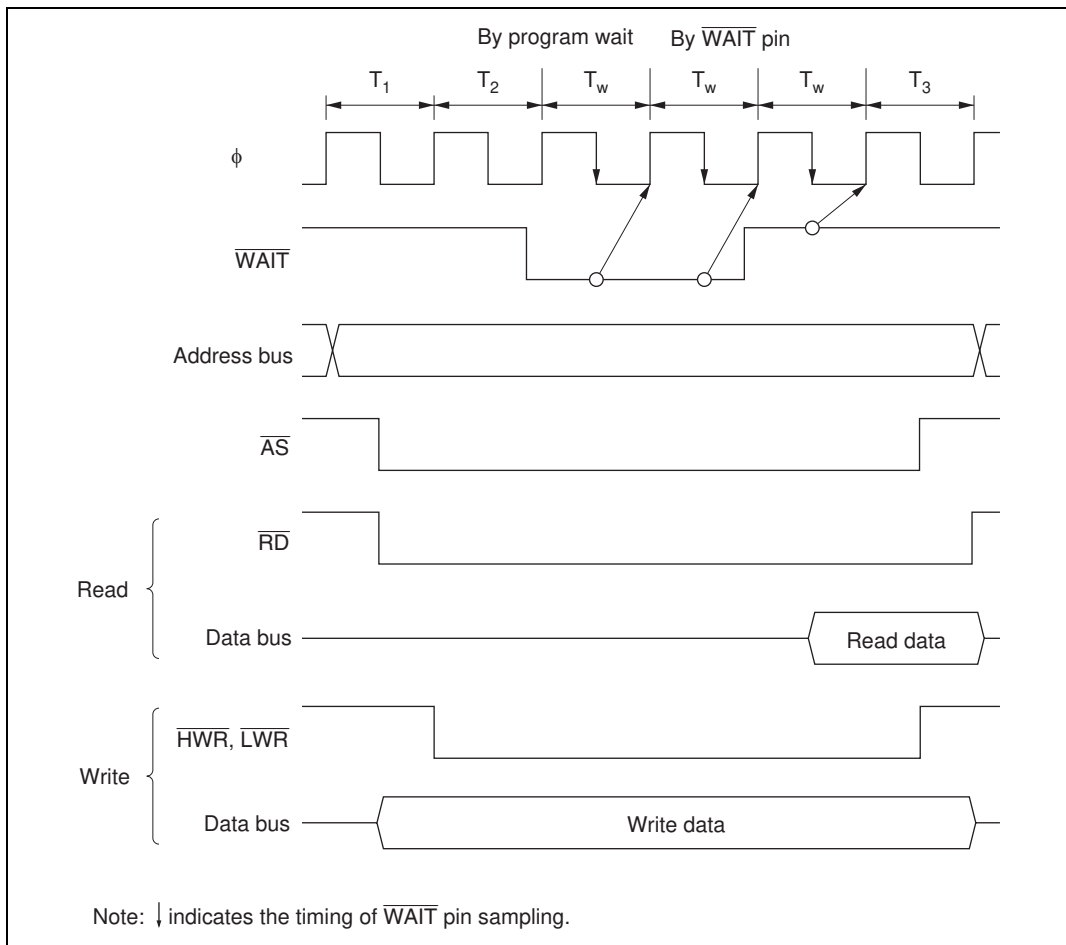

Figure 6.14 Example of Wait State Insertion Timing

The settings after a power-on reset are: 3-state access, 3 program wait state insertion, and \overline{WAIT} input disabled.

6.5 Burst ROM Interface

6.5.1 Overview

With the chip, external space area 0 can be designated as burst ROM space, and burst ROM interfacing can be performed. The burst ROM space interface enables 16-bit configuration ROM with burst access capability to be accessed at high speed.

Area 0 can be designated as burst ROM space by means of the BRSTRM bit in BCRH. Consecutive burst accesses of a maximum of 4 words or 8 words can be performed for CPU instruction fetches only. One or two states can be selected for burst access.

6.5.2 Basic Timing

The number of states in the initial cycle (full access) of the burst ROM interface is in accordance with the setting of the AST0 bit in ASTCR. Also, when the AST0 bit is set to 1, wait state insertion is possible. One or two states can be selected for the burst cycle, according to the setting of the BRSTS1 bit in BCRH. Wait states cannot be inserted. When area 0 is designated as burst ROM space, it becomes 16-bit access space regardless of the setting of the ABW0 bit in ABWCR.

When the BRSTS0 bit in BCRH is cleared to 0, burst access of up to 4 words is performed; when the BRSTS0 bit is set to 1, burst access of up to 8 words is performed.

The basic access timing for burst ROM space is shown in figures 6.15 (a) and (b). The timing shown in figure 6.15 (a) is for the case where the AST0 and BRSTS1 bits are both set to 1, and that in figure 6.15 (b) is for the case where both these bits are cleared to 0.

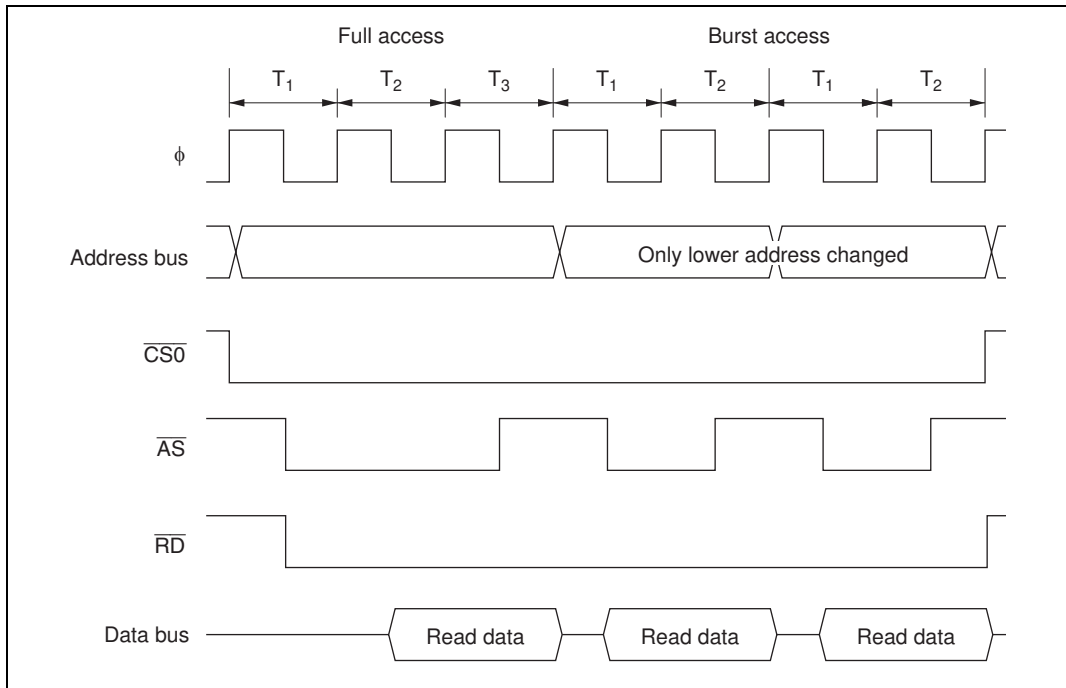

Figure 6.15 (a) Example of Burst ROM Access Timing (When $AST0 = BRSTS1 = 1$)

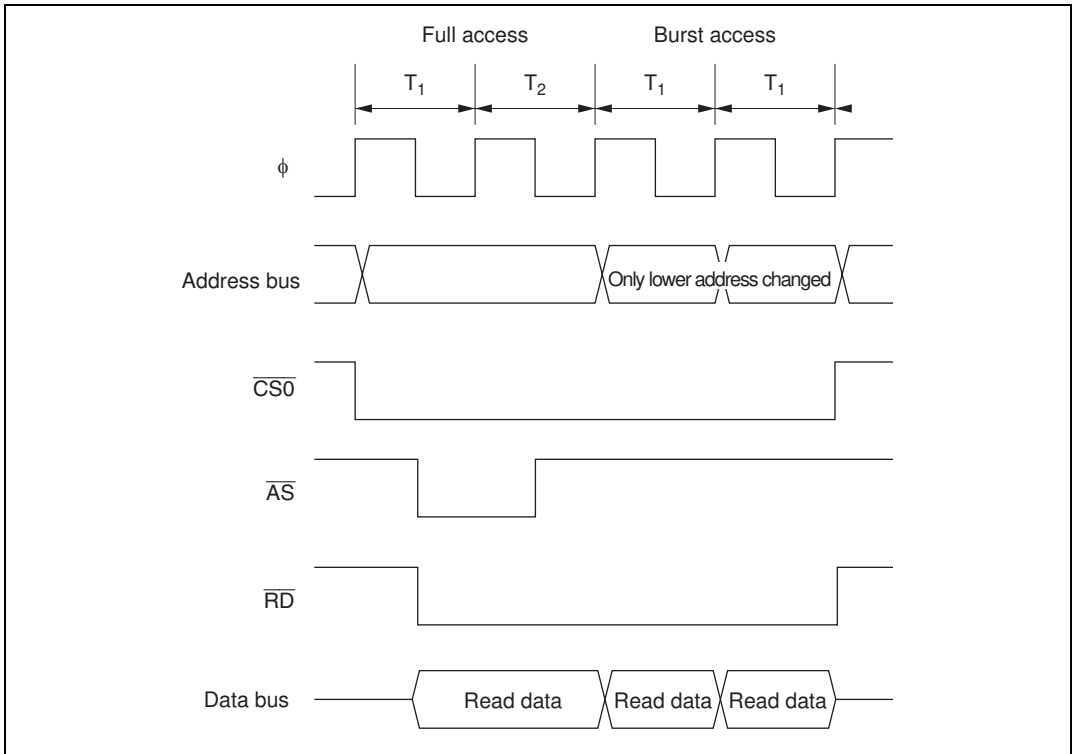

Figure 6.15 (b) Example of Burst ROM Access Timing (When $AST0 = BRSTS1 = 0$)

6.5.3 Wait Control

As with the basic bus interface, either program wait insertion or pin wait insertion using the \overline{WAIT} pin can be used in the initial cycle (full access) of the burst ROM interface. See section 6.4.5, Wait Control.

Wait states cannot be inserted in a burst cycle.

6.6 Idle Cycle

6.6.1 Operation

When the chip accesses external space, it can insert a 1-state idle cycle (T_1) between bus cycles in the following two cases: (1) when read accesses in different areas occur consecutively, and (2) when a write cycle occurs immediately after a read cycle. By inserting an idle cycle it is possible, for example, to avoid data collisions between ROM, with a long output floating time, and high-speed memory, I/O interfaces, and so on.

Consecutive Reads in Different Areas: If consecutive reads in different areas occur while the ICIS1 bit in BCRH is set to 1, an idle cycle is inserted at the start of the second read cycle. This is enabled in advanced mode.

Figure 6.16 shows an example of the operation in this case. In this example, bus cycle A is a read cycle from ROM with a long output floating time, and bus cycle B is a read cycle from SRAM, each being located in a different area. In (a), an idle cycle is not inserted, and a collision occurs in cycle B between the read data from ROM and that from SRAM. In (b), an idle cycle is inserted, and a data collision is prevented.

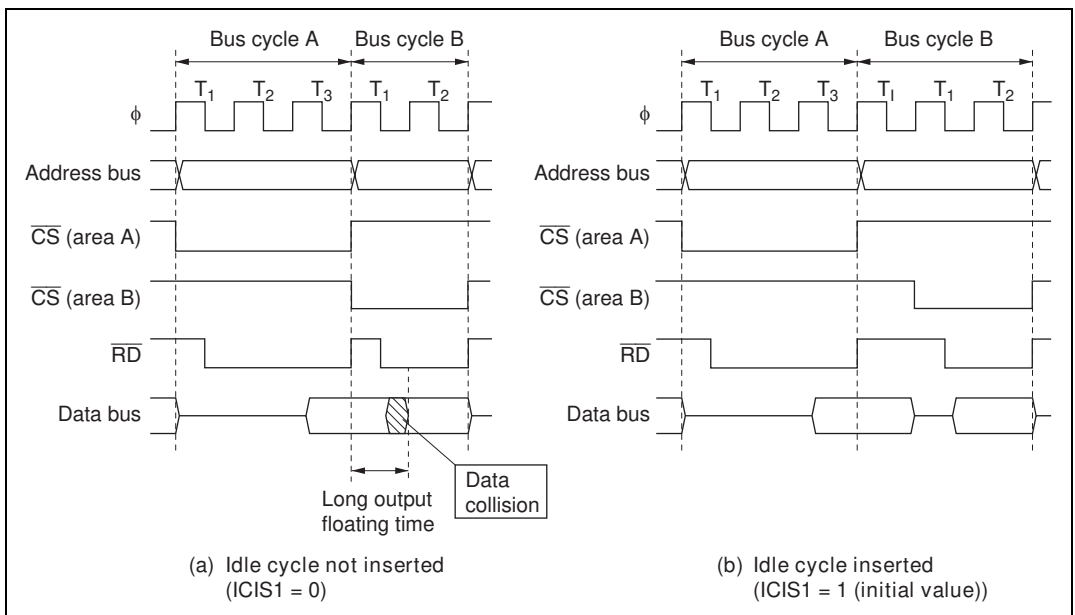

Figure 6.16 Example of Idle Cycle Operation (1)

Write after Read: If an external write occurs after an external read while the ICIS0 bit in BCRH is set to 1, an idle cycle is inserted at the start of the write cycle.

Figure 6.17 shows an example of the operation in this case. In this example, bus cycle A is a read cycle from ROM with a long output floating time, and bus cycle B is a CPU write cycle. In (a), an idle cycle is not inserted, and a collision occurs in cycle B between the read data from ROM and the CPU write data. In (b), an idle cycle is inserted, and a data collision is prevented.

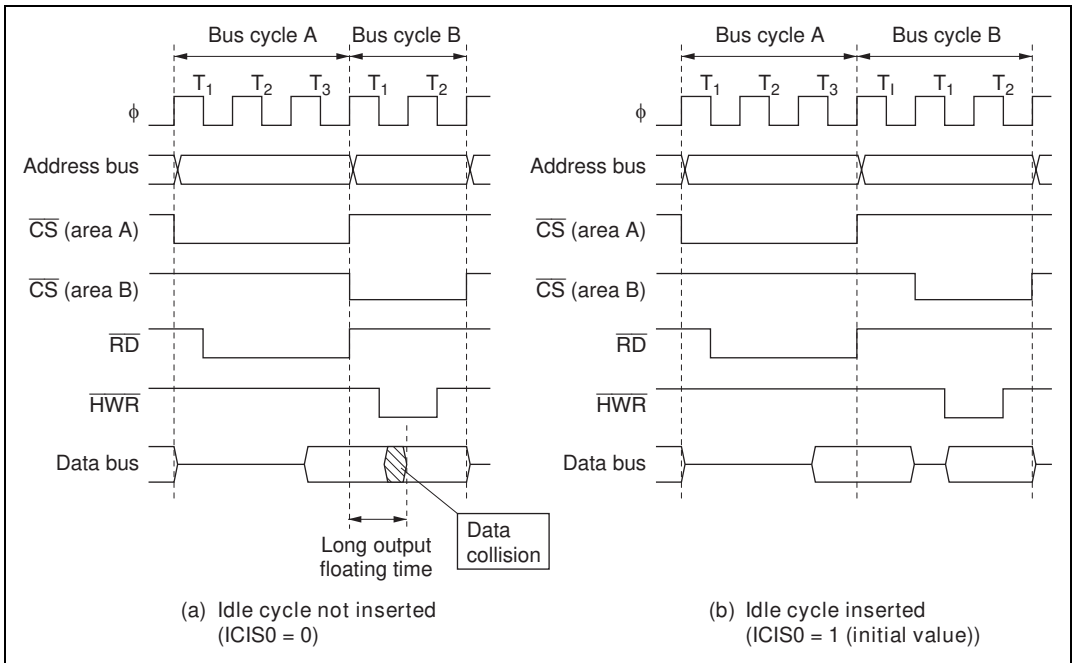

Figure 6.17 Example of Idle Cycle Operation (2)

Relationship between Chip Select (\overline{CS}) Signal and Read (\overline{RD}) Signal: Depending on the system's load conditions, the \overline{RD} signal may lag behind the \overline{CS} signal. An example is shown in figure 6.18.

In this case, with the setting for no idle cycle insertion (a), there may be a period of overlap between the bus cycle A \overline{RD} signal and the bus cycle B \overline{CS} signal.

Setting idle cycle insertion, as in (b), however, will prevent any overlap between the \overline{RD} and \overline{CS} signals.

In the initial state after reset release, idle cycle insertion (b) is set.

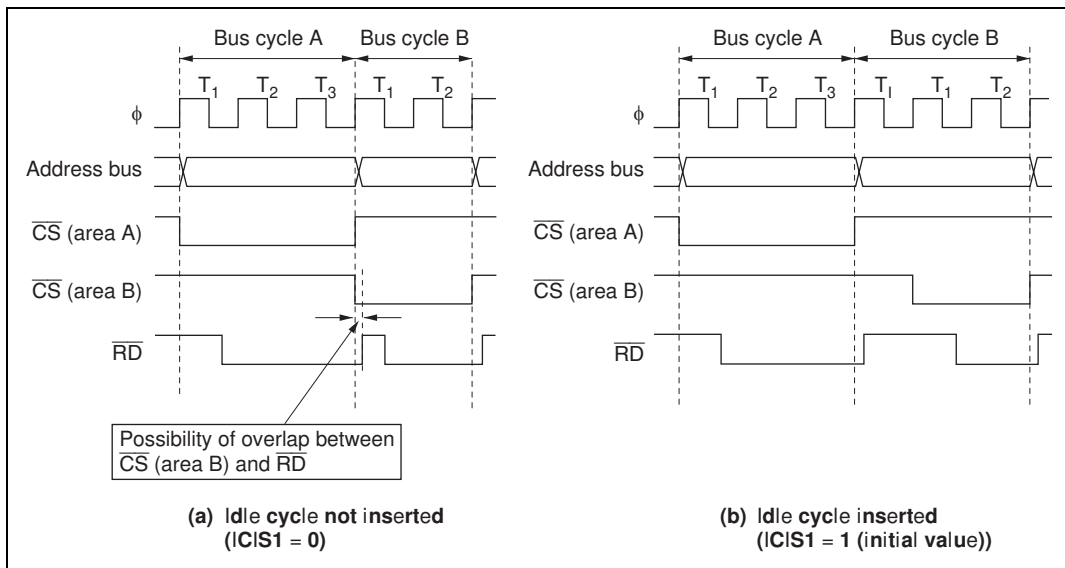

Figure 6.18 Relationship between Chip Select (\overline{CS}) and Read (\overline{RD})

6.6.2 Pin States in Idle Cycle

Table 6.5 shows the pin states in an idle cycle.

Table 6.5 Pin States in Idle Cycle

Pins	Pin State
A ₂₃ to A ₀	Contents of next bus cycle
D ₁₅ to D ₀	High impedance
$\overline{\text{CSn}}^*$	High
$\overline{\text{AS}}$	High
$\overline{\text{RD}}$	High
$\overline{\text{HWR}}$	High
$\overline{\text{LWR}}$	High

Note: * n = 0 to 7

6.7 Bus Release

6.7.1 Overview

The chip can release the external bus in response to a bus request from an external device. In the external bus released state, the internal bus master continues to operate as long as there is no external access.

If an internal bus master wants to make an external access in the external bus released state, it can issue a bus request off-chip.

6.7.2 Operation

In external expansion mode, the bus can be released to an external device by setting the BRLE bit in BCRL to 1. Driving the $\overline{\text{BREQ}}$ pin low issues an external bus request to the chip. When the $\overline{\text{BREQ}}$ pin is sampled, at the prescribed timing the $\overline{\text{BACK}}$ pin is driven low, and the address bus, data bus, and bus control signals are placed in the high-impedance state, establishing the external bus released state.

In the external bus released state, an internal bus master can perform accesses using the internal bus. When an internal bus master wants to make an external access, it temporarily defers activation of the bus cycle, and waits for the bus request from the external bus master to be dropped.

If the BREQOE bit in BCRL is set to 1, when an internal bus master wants to make an external access in the external bus released state, the $\overline{\text{BREQO}}$ pin is driven low and a request can be made off-chip to drop the bus request.

When the $\overline{\text{BREQ}}$ pin is driven high, the $\overline{\text{BACK}}$ pin is driven high at the prescribed timing and the external bus released state is terminated.

If an external bus release request and external access occur simultaneously, the order of priority is as follows:

(High) External bus release > Internal bus master external access (Low)

6.7.3 Pin States in External Bus Released State

Table 6.6 shows the pin states in the external bus released state.

Table 6.6 Pin States in Bus Released State

Pins	Pin State
A ₂₃ to A ₀	High impedance
D ₁₅ to D ₀	High impedance
$\overline{\text{CSn}}^*$	High impedance
$\overline{\text{AS}}$	High impedance
$\overline{\text{RD}}$	High impedance
$\overline{\text{HWR}}$	High impedance
$\overline{\text{LWR}}$	High impedance

Note: * n = 0 to 7

6.7.4 Transition Timing

Figure 6.19 shows the timing for transition to the bus released state.

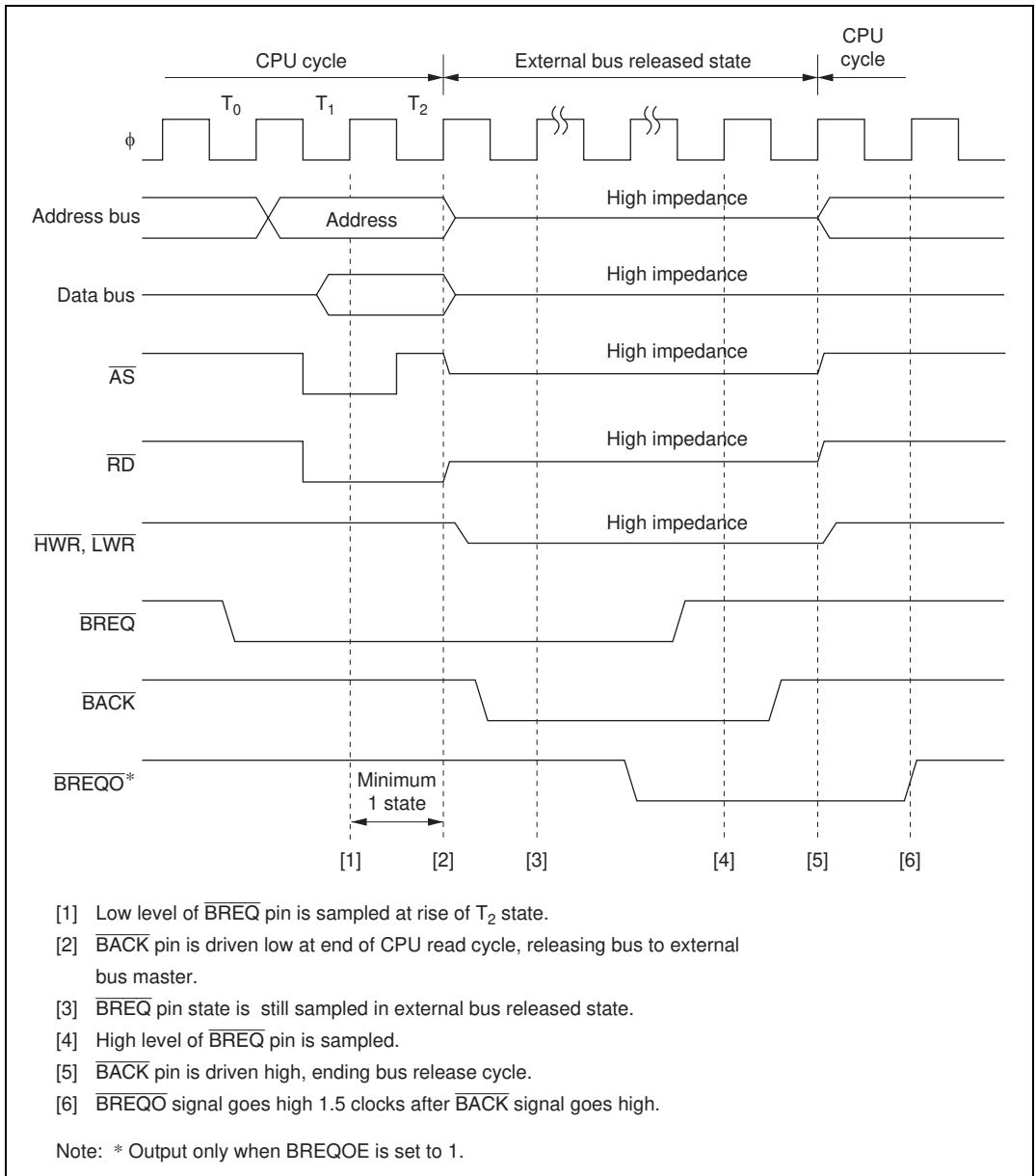

Figure 6.19 Bus Released State Transition Timing

6.7.5 Usage Note

Do not set MSTPCR to H'FFFF or H'EFFF, since the external bus release function will halt if a transition is made to sleep mode when either of these settings has been made.

6.8 Bus Arbitration

6.8.1 Overview

The chip has a bus arbiter that arbitrates bus master operations.

There are two bus masters, the CPU and DTC, which perform read/write operations when they have possession of the bus. Each bus master requests the bus by means of a bus request signal. The bus arbiter determines priorities at the prescribed timing, and permits use of the bus by means of a bus request acknowledge signal. The selected bus master then takes possession of the bus and begins its operation.

6.8.2 Operation

The bus arbiter detects the bus masters' bus request signals, and if the bus is requested, sends a bus request acknowledge signal to the bus master making the request. If there are bus requests from more than one bus master, the bus request acknowledge signal is sent to the one with the highest priority. When a bus master receives the bus request acknowledge signal, it takes possession of the bus until that signal is canceled.

The order of priority of the bus masters is as follows:

(High) DTC > CPU (Low)

An internal bus access by an internal bus master and external bus release, can be executed in parallel.

In the event of simultaneous external bus release request and internal bus master external access request generation, the order of priority is as follows:

(High) External bus release > Internal bus master external access (Low)

6.8.3 Bus Transfer Timing

Even if a bus request is received from a bus master with a higher priority than that of the bus master that has acquired the bus and is currently operating, the bus is not necessarily transferred immediately. There are specific times at which each bus master can relinquish the bus.

CPU: The CPU is the lowest-priority bus master, and if a bus request is received from the DTC, the bus arbiter transfers the bus to the bus master that issued the request. The timing for transfer of the bus is as follows:

- The bus is transferred at a break between bus cycles. However, if a bus cycle is executed in discrete operations, as in the case of a longword-size access, the bus is not transferred between the operations. See appendix A.5, Bus States during Instruction Execution, for timings at which the bus is not transferred.
- If the CPU is in sleep mode, it transfers the bus immediately.

DTC: The DTC sends the bus arbiter a request for the bus when an activation request is generated.

The DTC can release the bus after a vector read, a register information read (3 states), a single data transfer, or a register information write (3 states). It does not release the bus during a register information read (3 states), a single data transfer, or a register information write (3 states).

6.8.4 External Bus Release Usage Note

External bus release can be performed on completion of an external bus cycle. The \overline{RD} signal remains low until the end of the external bus cycle. Therefore, when external bus release is performed, the \overline{RD} signal may change from the low level to the high-impedance state.

6.9 Resets and the Bus Controller

In a reset, the chip, including the bus controller, enters the reset state at that point, and any executing bus cycle is discontinued.

Section 7 Data Transfer Controller

7.1 Overview

The chip includes a data transfer controller (DTC). The DTC can be activated for data transfer by an interrupt or software.

7.1.1 Features

The features of the DTC are:

- Transfer possible over any number of channels
 - Transfer information is stored in memory
 - One activation source can trigger a number of data transfers (chain transfer)
 - Chain transfer execution can be set after data transfer (when counter = 0)
- Selection of transfer modes
 - Normal, repeat, and block transfer modes available
 - Incrementing, decrementing, and fixing of source and destination addresses can be selected
- Direct specification of 16-Mbyte address space possible
 - 24-bit transfer source and destination addresses can be specified
- Transfer can be set in byte or word units
- A CPU interrupt can be requested for the interrupt that activated the DTC
 - An interrupt request can be issued to the CPU after one data transfer ends
 - An interrupt request can be issued to the CPU after all the specified data transfers have ended
- Activation by software is possible
- Module stop mode can be set
 - The initial setting enables DTC registers to be accessed. DTC operation is halted by setting module stop mode

7.1.2 Block Diagram

Figure 7.1 shows a block diagram of the DTC.

The DTC's register information is stored in the on-chip RAM*. A 32-bit bus connects the DTC to the on-chip RAM (1 kbyte), enabling 32-bit, 1-state reading and writing of DTC register information.

Note: * When the DTC is used, the RAME bit in SYSCR must be set to 1.

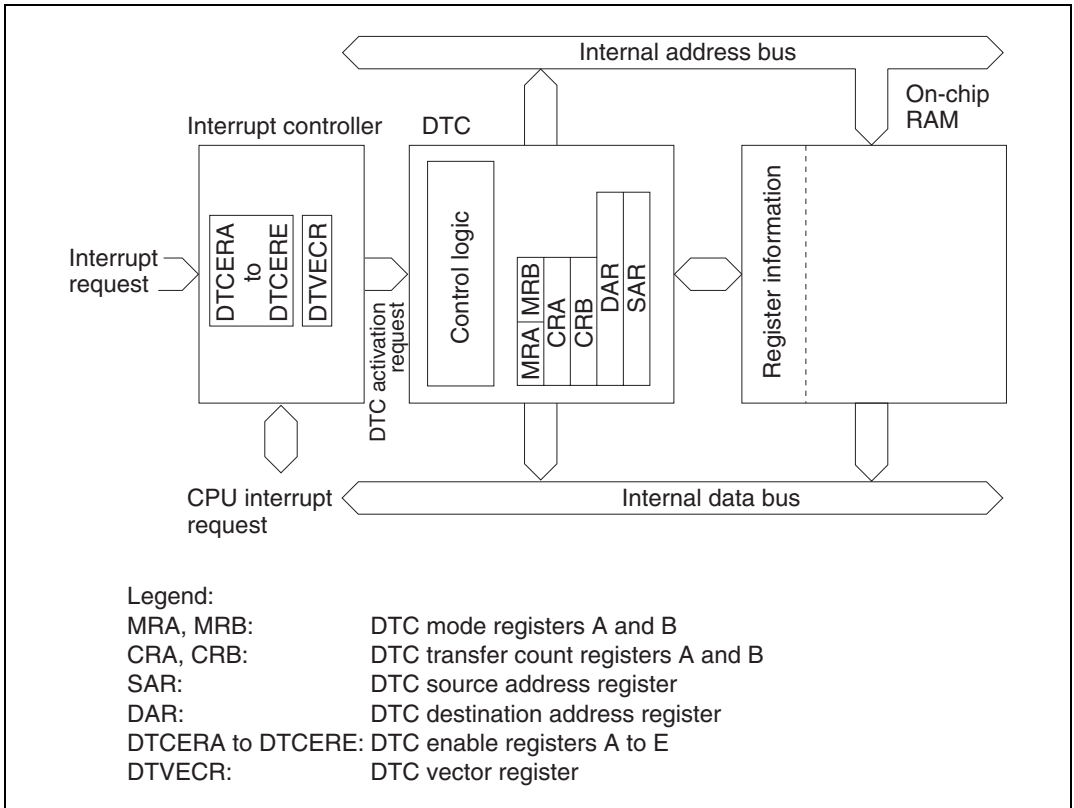

Figure 7.1 Block Diagram of DTC

7.1.3 Register Configuration

Table 7.1 summarizes the DTC registers.

Table 7.1 DTC Registers

Name	Abbreviation	R/W	Initial Value	Address*1
DTC mode register A	MRA	—*2	Undefined	—*3
DTC mode register B	MRB	—*2	Undefined	—*3
DTC source address register	SAR	—*2	Undefined	—*3
DTC destination address register	DAR	—*2	Undefined	—*3
DTC transfer count register A	CRA	—*2	Undefined	—*3
DTC transfer count register B	CRB	—*2	Undefined	—*3
DTC enable registers	DT CER	R/W	H'00	H'FF30 to H'FF34
DTC vector register	DTVECR	R/W	H'00	H'FF37
Module stop control register	MSTPCR	R/W	H'3FFF	H'FF3C

- Notes:
1. Lower 16 bits of the address.
 2. Registers within the DTC cannot be read or written to directly.
 3. Register information is located in on-chip RAM addresses H'F800 to H'FBFF. It cannot be located in external space. When the DTC is used, do not clear the RAME bit in SYSCR to 0.

7.2 Register Descriptions

7.2.1 DTC Mode Register A (MRA)

Bit	:	7	6	5	4	3	2	1	0
		SM1	SM0	DM1	DM0	MD1	MD0	DTS	Sz
Initial value :		Unde- fined	Unde- fined	Unde- fined	Unde- fined	Unde- fined	Unde- fined	Unde- fined	Unde- fined
R/W	:	—	—	—	—	—	—	—	—

MRA is an 8-bit register that controls the DTC operating mode.

Bits 7 and 6—Source Address Mode 1 and 0 (SM1, SM0): These bits specify whether SAR is to be incremented, decremented, or left fixed after a data transfer.

Bit 7 SM1	Bit 6 SM0	Description
0	—	SAR is fixed
1	0	SAR is incremented after a transfer (by +1 when Sz = 0; by +2 when Sz = 1)
	1	SAR is decremented after a transfer (by -1 when Sz = 0; by -2 when Sz = 1)

Bits 5 and 4—Destination Address Mode 1 and 0 (DM1, DM0): These bits specify whether DAR is to be incremented, decremented, or left fixed after a data transfer.

Bit 5 DM1	Bit 4 DM0	Description
0	—	DAR is fixed
1	0	DAR is incremented after a transfer (by +1 when Sz = 0; by +2 when Sz = 1)
	1	DAR is decremented after a transfer (by -1 when Sz = 0; by -2 when Sz = 1)

Bits 3 and 2—DTC Mode (MD1, MD0): These bits specify the DTC transfer mode.

Bit 3 MD1	Bit 2 MD0	Description
0	0	Normal mode
	1	Repeat mode
1	0	Block transfer mode
	1	—

Bit 1—DTC Transfer Mode Select (DTS): Specifies whether the source side or the destination side is set to be a repeat area or block area, in repeat mode or block transfer mode.

Bit 1 DTS	Description
0	Destination side is repeat area or block area
1	Source side is repeat area or block area

Bit 0—DTC Data Transfer Size (Sz): Specifies the size of data to be transferred.

Bit 0 Sz	Description
0	Byte-size transfer
1	Word-size transfer

7.2.2 DTC Mode Register B (MRB)

Bit	:	7	6	5	4	3	2	1	0
		CHNE	DISEL	CHNS	—	—	—	—	—
Initial value	:	Unde- fined	Unde- fined	Unde- fined	Unde- fined	Unde- fined	Unde- fined	Unde- fined	Unde- fined
R/W	:	—	—	—	—	—	—	—	—

MRB is an 8-bit register that controls the DTC operating mode.

Bit 7—DTC Chain Transfer Enable (CHNE): Specifies chain transfer. With chain transfer, a number of data transfers can be performed consecutively in response to a single transfer request.

In data transfer with CHNE set to 1, determination of the end of the specified number of transfers, clearing of the interrupt source flag, and clearing of DTCER are not performed.

When CHNE is set to 1, the chain transfer condition can be selected with the CHNS bit.

Bit 7

CHNE	Description
0	End of DTC data transfer (activation waiting state)
1	DTC chain transfer (new register information is read, then data is transferred)

Bit 6—DTC Interrupt Select (DISEL): Specifies whether interrupt requests to the CPU are disabled or enabled after a data transfer.

Bit 6

DISEL	Description
0	After a data transfer ends, the CPU interrupt is disabled unless the transfer counter is 0 (the DTC clears the interrupt source flag of the activating interrupt to 0)
1	After a data transfer ends, the CPU interrupt is enabled (the DTC does not clear the interrupt source flag of the activating interrupt to 0)

Bit 5—DTC Chain Transfer Select (CHNS): Specifies the chain transfer condition when CHNE is 1.

Bit 7 CHNE	Bit 5 CHNS	Description
0	–	No chain transfer (DTC data transfer end, activation waiting state entered)
1	0	DTC chain transfer
	1	Chain transfer only when transfer counter = 0

Bits 4 to 0—Reserved: These bits have no effect on DTC operation in the chip and should always be written with 0.

7.2.3 DTC Source Address Register (SAR)

Bit	:	23	22	21	20	19	---	---	---	4	3	2	1	0
Initial value	:	Unde- fined	Unde- fined	Unde- fined	Unde- fined	Unde- fined	---	---	---	Unde- fined	Unde- fined	Unde- fined	Unde- fined	Unde- fined
R/W	:	—	—	—	—	—	---	---	---	—	—	—	—	—

SAR is a 24-bit register that designates the source address of data to be transferred by the DTC. For word-size transfer, specify an even source address.

7.2.4 DTC Destination Address Register (DAR)

Bit	:	23	22	21	20	19	---	---	---	4	3	2	1	0
Initial value	:	Unde- fined	Unde- fined	Unde- fined	Unde- fined	Unde- fined	---	---	---	Unde- fined	Unde- fined	Unde- fined	Unde- fined	Unde- fined
R/W	:	—	—	—	—	—	---	---	---	—	—	—	—	—

DAR is a 24-bit register that designates the destination address of data to be transferred by the DTC. For word-size transfer, specify an even destination address.

7.2.5 DTC Transfer Count Register A (CRA)

Bit	:	15	14	13	12	11	10	9	8	7	6	5	4	3	2	1	0
Initial value	:	Unde- fined	Unde- fined	Unde- fined	Unde- fined	Unde- fined	Unde- fined	Unde- fined	Unde- fined	Unde- fined	Unde- fined	Unde- fined	Unde- fined	Unde- fined	Unde- fined	Unde- fined	Unde- fined
R/W	:	—	—	—	—	—	—	—	—	—	—	—	—	—	—	—	—
		← CRAH →								← CRAL →							

CRA is a 16-bit register that designates the number of times data is to be transferred by the DTC.

In normal mode, the entire CRA register functions as a 16-bit transfer counter (1 to 65,536). It is decremented by 1 every time data is transferred, and transfer ends when the count reaches H'0000.

In repeat mode or block transfer mode, the CRA register is divided into two parts: the upper 8 bits (CRAH) and the lower 8 bits (CRAL). CRAH holds the number of transfers while CRAL functions as an 8-bit transfer counter (1 to 256). CRAL is decremented by 1 every time data is

transferred, and the contents of CRAH are sent when the count reaches H'00. This operation is repeated.

7.2.6 DTC Transfer Count Register B (CRB)

Bit	:	15	14	13	12	11	10	9	8	7	6	5	4	3	2	1	0
Initial value	:	Unde- fined	Unde- fined	Unde- fined	Unde- fined	Unde- fined	Unde- fined	Unde- fined	Unde- fined	Unde- fined	Unde- fined	Unde- fined	Unde- fined	Unde- fined	Unde- fined	Unde- fined	Unde- fined
R/W	:	—	—	—	—	—	—	—	—	—	—	—	—	—	—	—	—

CRB is a 16-bit register that designates the number of times data is to be transferred by the DTC in block transfer mode. It functions as a 16-bit transfer counter (1 to 65,536) that is decremented by 1 every time data is transferred, and transfer ends when the count reaches H'0000.

7.2.7 DTC Enable Registers (DTCER)

Bit	:	7	6	5	4	3	2	1	0
		DTCE7	DTCE6	DTCE5	DTCE4	DTCE3	DTCE2	DTCE1	DTCE0
Initial value	:	0	0	0	0	0	0	0	0
R/W	:	R/W	R/W	R/W	R/W	R/W	R/W	R/W	R/W

The DTC enable registers comprise six 8-bit readable/writable registers, DTCERA to DTCERF, with bits corresponding to the interrupt sources that can activate the DTC. These bits enable or disable DTC service for the corresponding interrupt sources.

The DTC enable registers are initialized to H'00 by a reset and in hardware standby mode.

Bit n—DTC Activation Enable (DTCE_n)

Bit n DTCE _n	Description
0	DTC activation by this interrupt is disabled (Initial value) [Clearing conditions] <ul style="list-style-type: none"> • When the DISEL bit is 1 and the data transfer has ended • When the specified number of transfers have ended
1	DTC activation by this interrupt is enabled [Holding condition] When the DISEL bit is 0 and the specified number of transfers have not ended

(n = 7 to 0)

A DTCE bit can be set for each interrupt source that can activate the DTC. The correspondence between interrupt sources and DTCE bits is shown in table 7.5, together with the vector numbers generated by the interrupt controller.

For DTCE bit setting, read/write operations must be performed using bit-manipulation instructions such as BSET and BCLR. For the initial setting only, however, when multiple activation sources are set at one time, it is possible to disable interrupts and write after executing a dummy read on the relevant register.

7.2.8 DTC Vector Register (DTVECR)

Bit	:	7	6	5	4	3	2	1	0
		SWDTE	DTVEC6	DTVEC5	DTVEC4	DTVEC3	DTVEC2	DTVEC1	DTVEC0
Initial value	:	0	0	0	0	0	0	0	0
R/W	:	R/(W)	R/(W)*	R/(W)*	R/(W)*	R/(W)*	R/(W)*	R/(W)*	R/(W)*

Note: * Bits DTVEC6 to DTVEC0 can be written to when SWDTE = 0.

DTVECR is an 8-bit readable/writable register that enables or disables DTC activation by software, and sets a vector number for the software activation interrupt.

DTVECR is initialized to H'00 by a reset and in hardware standby mode.

Bit 7—DTC Software Activation Enable (SWDTE): Enables or disables DTC activation by software.

Bit 7

SWDTE	Description
0	DTC software activation is disabled (Initial value) [Clearing conditions] <ul style="list-style-type: none"> When the DISEL bit is 0 and the specified number of transfers have not ended When 0 is written after a software activation data-transfer-complete interrupt is issued to the CPU
1	DTC software activation is enabled [Holding conditions] <ul style="list-style-type: none"> When the DISEL bit is 1 and data transfer has ended When the specified number of transfers have ended During data transfer due to software activation

Bits 6 to 0—DTC Software Activation Vectors 6 to 0 (DTVEC6 to DTVEC0): These bits specify a vector number for DTC software activation.

The vector address is expressed as $H'0400 + ((\text{vector number}) \ll 1)$. $\ll 1$ indicates a one-bit left-shift. For example, when $DTVEC6$ to $DTVEC0 = H'10$, the vector address is $H'0420$.

7.2.9 Module Stop Control Register (MSTPCR)

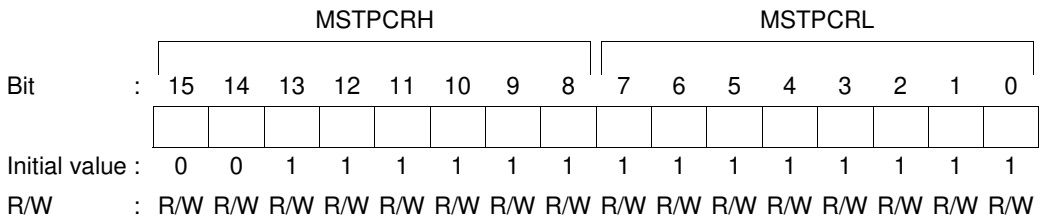

MSTPCR is a 16-bit readable/writable register that performs module stop mode control.

When the MSTP14 bit in MSTPCR is set to 1, DTC operation stops at the end of the bus cycle and a transition is made to module stop mode. However, 1 cannot be written in the MSTP14 bit while the DTC is operating. For details, see section 19.5, Module Stop Mode.

MSTPCR is initialized to $H'3FFF$ by a reset and in hardware standby mode. It is not initialized in software standby mode.

Bit 14—Module Stop (MSTP14): Specifies the DTC module stop mode.

Bit 14

MSTP14	Description	
0	DTC module stop mode cleared	(Initial value)
1	DTC module stop mode set	

7.3 Operation

7.3.1 Overview

When activated, the DTC reads register information that is already stored in memory and transfers data on the basis of that register information. After the data transfer, it writes updated register information back to memory. Pre-storage of register information in memory makes it possible to transfer data over any required number of channels. Setting the CHNE bit to 1 makes it possible to perform a number of transfers with a single activation. A setting can also be made to have chain transfer performed only when the transfer counter value is 0. This enables DTC re-setting to be performed by the DTC itself.

Figure 7.2 shows a flowchart of DTC operation, and table 7.2 summarizes the chain transfer conditions (combinations for performing the second and third transfers are omitted).

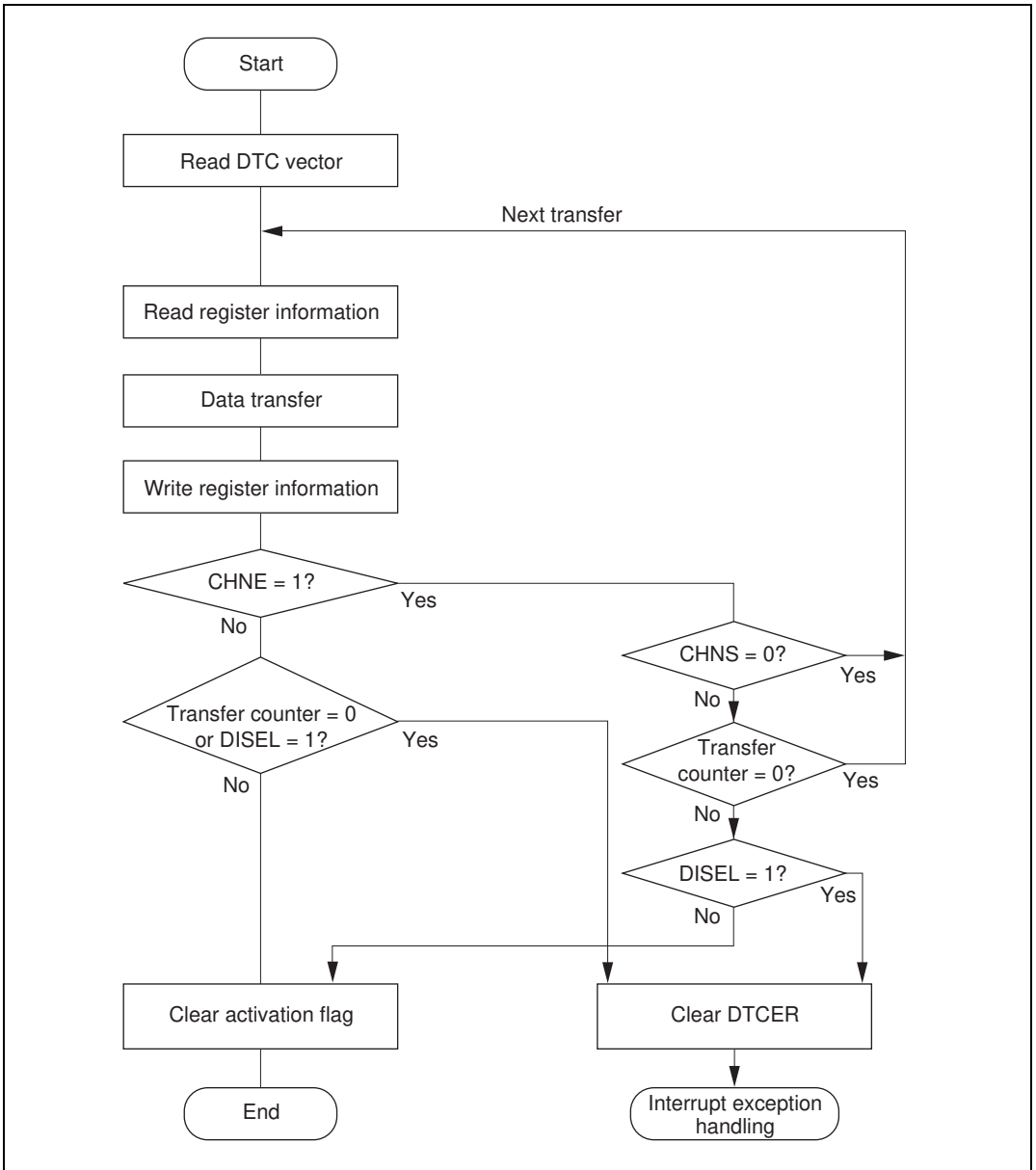

Figure 7.2 Flowchart of DTC Operation

Table 7.2 Chain Transfer Conditions

1st Transfer				2nd Transfer				DTC Transfer
CHNE	CHNS	DISEL	CR	CHNE	CHNS	DISEL	CR	
0	—	0	Not 0	—	—	—	—	Ends at 1st transfer
0	—	0	0	—	—	—	—	Ends at 1st transfer
0	—	1	—	—	—	—	—	Interrupt request to CPU
1	0	—	—	0	—	0	Not 0	Ends at 2nd transfer
				0	—	0	0	Ends at 2nd transfer
				0	—	1	—	Interrupt request to CPU
1	1	0	Not 0	—	—	—	—	Ends at 1st transfer
1	1	—	0	0	—	0	Not 0	Ends at 2nd transfer
				0	—	0	0	Ends at 2nd transfer
				0	—	1	—	Interrupt request to CPU
1	1	1	Not 0	—	—	—	—	Ends at 1st transfer
				—	—	—	—	Interrupt request to CPU

The DTC transfer mode can be normal mode, repeat mode, or block transfer mode.

The 24-bit SAR designates the DTC transfer source address and the 24-bit DAR designates the transfer destination address. After each transfer, SAR and DAR are independently incremented, decremented, or left fixed.

Table 7.3 outlines the functions of the DTC.

Table 7.3 DTC Functions

Transfer Mode	Activation Source	Address Registers	
		Transfer Source	Transfer Destination
<ul style="list-style-type: none"> • Normal mode <ul style="list-style-type: none"> — One transfer request transfers one byte or one word — Memory addresses are incremented or decremented by 1 or 2 — Up to 65,536 transfers possible • Repeat mode <ul style="list-style-type: none"> — One transfer request transfers one byte or one word — Memory addresses are incremented or decremented by 1 or 2 — After the specified number of transfers (1 to 256), the initial state resumes and operation continues • Block transfer mode <ul style="list-style-type: none"> — One transfer request transfers a block of the specified size — Block size is from 1 to 256 bytes or words — Up to 65,536 transfers possible — A block area can be designated at either the source or destination 	<ul style="list-style-type: none"> • IRQ • TPU TGI • 8-bit timer CMI • SCI TXI or RXI • A/D converter ADI • Software 	24 bits	24 bits

7.3.2 Activation Sources

The DTC operates when activated by an interrupt or by a write to DTVECR by software. An interrupt request can be directed to the CPU or DTC, as designated by the corresponding DTCER bit. An interrupt becomes a DTC activation source when the corresponding bit is set to 1, and a CPU interrupt source when the bit is cleared to 0.

At the end of a data transfer (or the last consecutive transfer in the case of chain transfer), the activation source or corresponding DTCER bit is cleared. Table 7.4 shows activation source and DTCER clearance. The activation source flag, in the case of RXI0, for example, is the RDRF flag of SCIO.

Table 7.4 Activation Source and DTCER Clearance

Activation Source	When the DIESEL Bit Is 0 and the Specified Number of Transfers Have Not Ended	When the DIESEL Bit Is 1, or when the Specified Number of Transfers Have Ended
Software activation	The SWDTE bit is cleared to 0	<ul style="list-style-type: none"> • The SWDTE bit remains set to 1 • An interrupt is issued to the CPU
Interrupt activation	<ul style="list-style-type: none"> • The corresponding DTCER bit remains set to 1 • The activation source flag is cleared to 0 	<ul style="list-style-type: none"> • The corresponding DTCER bit is cleared to 0 • The activation source flag remains set to 1 • A request is issued to the CPU for the activation source interrupt

Figure 7.3 shows a block diagram of activation source control. For details see section 5, Interrupt Controller.

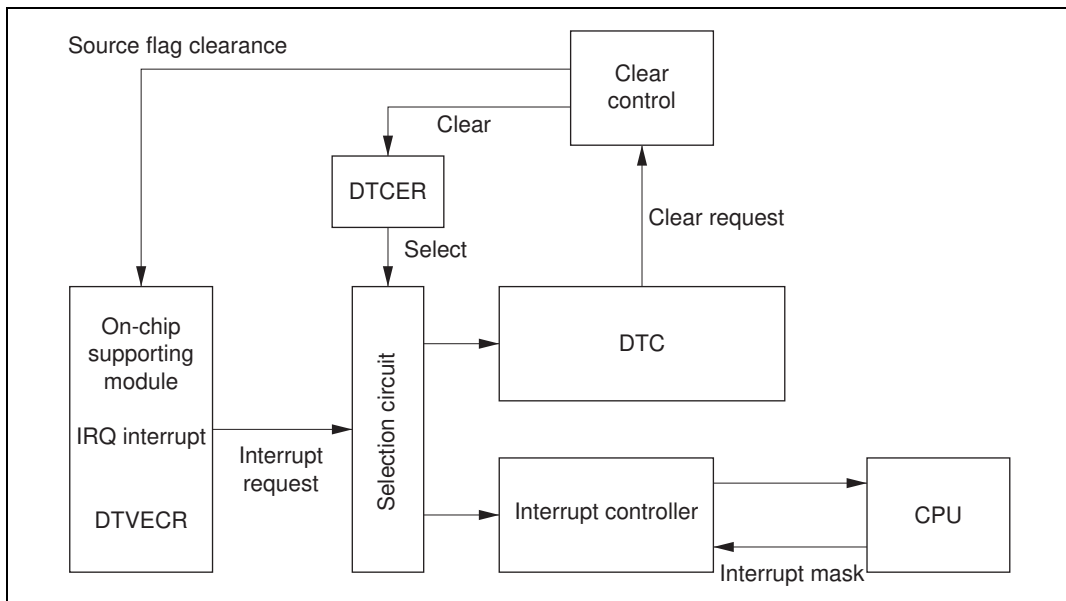

Figure 7.3 Block Diagram of DTC Activation Source Control

When an interrupt has been designated a DTC activation source, existing CPU mask level and interrupt controller priorities have no effect. If there is more than one activation source at the same time, the DTC operates in accordance with the default priorities.

7.3.3 DTC Vector Table

Figure 7.4 shows the correspondence between DTC vector addresses and register information.

Table 7.5 shows the correspondence between activation, vector addresses, and DTGER bits. When the DTC is activated by software, the vector address is obtained from: $H'0400 + (DTVECR[6:0] \ll 1)$ (where $\ll 1$ indicates a 1-bit left shift). For example, if DTVECR is H'10, the vector address is H'0420.

The DTC reads the start address of the register information from the vector address set for each activation source, and then reads the register information from that start address. The register information can be placed at predetermined addresses in the on-chip RAM. The start address of the register information should be an integral multiple of four.

The configuration of the vector address is a 2-byte unit. These two bytes specify the lower bits of the address in the on-chip RAM.

Interrupt Source	Origin of Interrupt Source	Vector Number	Vector Address	DTCE*	Priority
TGI3A (GR3A compare match/ input capture)	TPU channel 3	48	H'0460	DTCEC5	High ↑ Low
TGI3B (GR3B compare match/ input capture)		49	H'0462	DTCEC4	
TGI3C (GR3C compare match/ input capture)		50	H'0464	DTCEC3	
TGI3D (GR3D compare match/ input capture)		51	H'0466	DTCEC2	
TGI4A (GR4A compare match/ input capture)	TPU channel 4	56	H'0470	DTCEC1	
TGI4B (GR4B compare match/ input capture)		57	H'0472	DTCEC0	
TGI5A (GR5A compare match/ input capture)	TPU channel 5	60	H'0478	DTCED5	
TGI5B (GR5B compare match/ input capture)		61	H'047A	DTCED4	
CMIA0	8-bit timer channel 0	64	H'0480	DTCED3	
CMIB0		65	H'0482	DTCED2	
CMIA1	8-bit timer channel 1	68	H'0488	DTCED1	
CMIB1		69	H'048A	DTCED0	
RX10 (receive-data-full 0)	SCI channel 0	81	H'04A2	DTCEE3	
TX10 (transmit-data-empty 0)		82	H'04A4	DTCEE2	
RX11 (receive-data-full 1)	SCI channel 1	85	H'04AA	DTCEE1	
TX11 (transmit-data-empty 1)		86	H'04AC	DTCEE0	

Note: *DTCE bits with no corresponding interrupt are reserved, and should be written with 0.

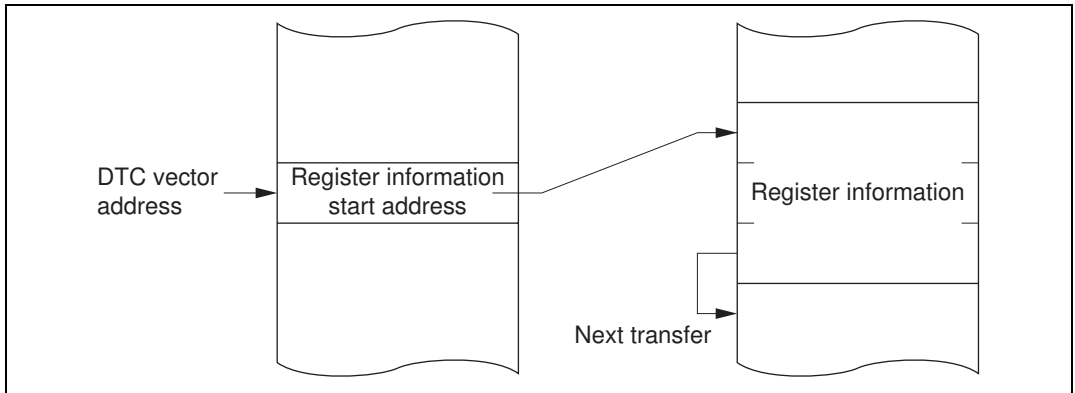

Figure 7.4 Correspondence between DTC Vector Address and Register Information

7.3.4 Location of Register Information in Address Space

Figure 7.5 shows how the register information should be located in the address space.

Locate the MRA, SAR, MRB, DAR, CRA, and CRB registers, in that order, from the start address of the register information (contents of the vector address). In the case of chain transfer, register information should be located in consecutive areas.

Locate the register information in the on-chip RAM (addresses: H'FFF800 to H'FFFBFF).

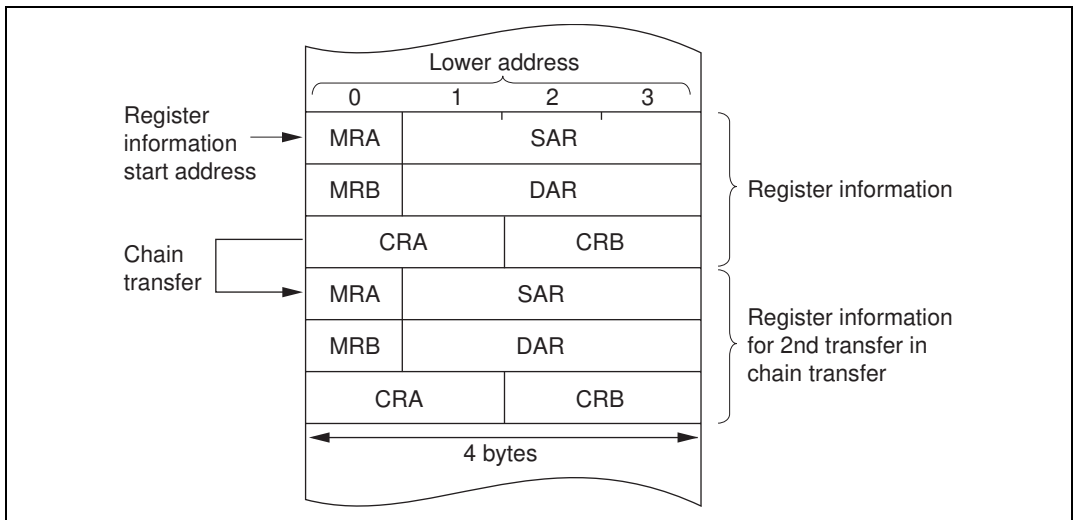

Figure 7.5 Location of DTC Register Information in Address Space

7.3.5 Normal Mode

In normal mode, one operation transfers one byte or one word of data.

From 1 to 65,536 transfers can be specified. Once the specified number of transfers have ended, a CPU interrupt can be requested.

Table 7.6 lists the register information in normal mode and figure 7.6 shows the memory map in normal mode.

Table 7.6 Register Information in Normal Mode

Name	Abbreviation	Function
DTC source address register	SAR	Designates source address
DTC destination address register	DAR	Designates destination address
DTC transfer count register A	CRA	Designates transfer count
DTC transfer count register B	CRB	Not used

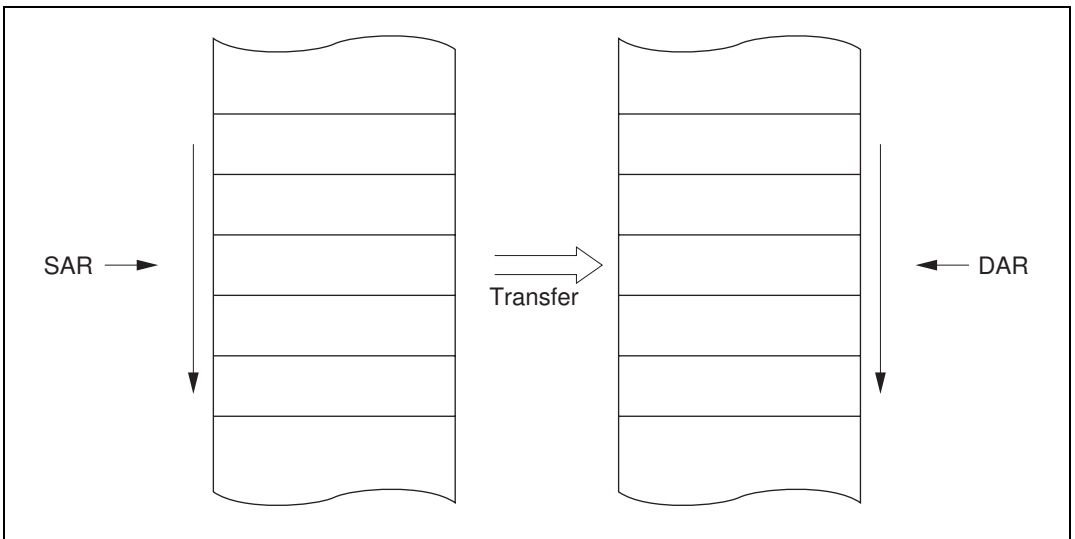

Figure 7.6 Memory Map in Normal Mode

7.3.6 Repeat Mode

In repeat mode, one operation transfers one byte or one word of data.

From 1 to 256 transfers can be specified. Once the specified number of transfers have ended, the initial state of the transfer counter and the address register specified as the repeat area is restored, and transfer is repeated. In repeat mode the transfer counter value does not reach H'00, and therefore CPU interrupts cannot be requested when DISEL = 0.

Table 7.7 lists the register information in repeat mode and figure 7.7 shows the memory map in repeat mode.

Table 7.7 Register Information in Repeat Mode

Name	Abbreviation	Function
DTC source address register	SAR	Designates source address
DTC destination address register	DAR	Designates destination address
DTC transfer count register AH	CRAH	Holds number of transfers
DTC transfer count register AL	CRAL	Transfer counter
DTC transfer count register B	CRB	Not used

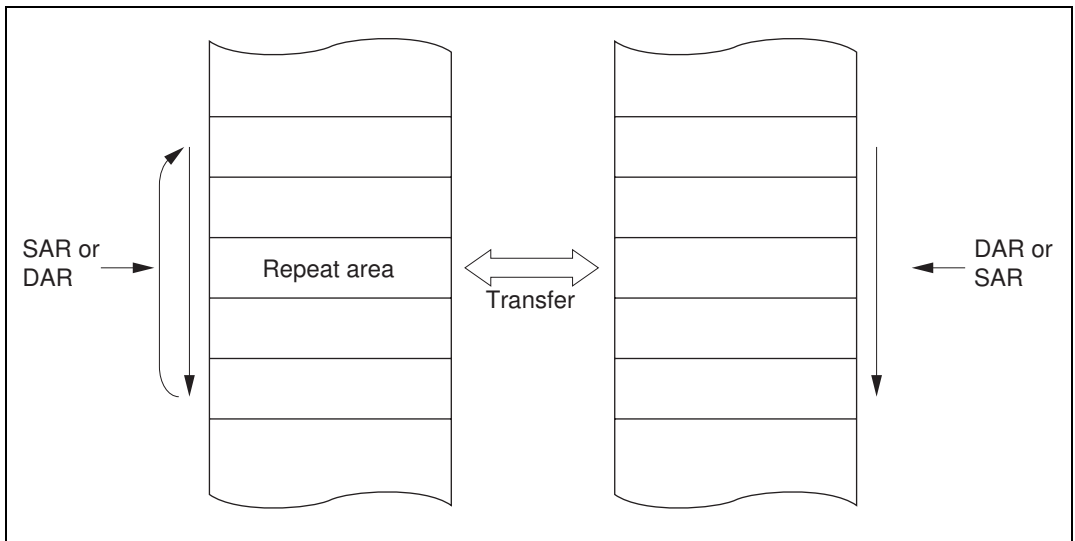

Figure 7.7 Memory Map in Repeat Mode

7.3.7 Block Transfer Mode

In block transfer mode, one operation transfers one block of data. Either the transfer source or the transfer destination is designated as a block area.

The block size is 1 to 256. When the transfer of one block ends, the initial state of the block size counter and the address register specified as the block area is restored. The other address register is then incremented, decremented, or left fixed.

From 1 to 65,536 transfers can be specified. Once the specified number of transfers have ended, a CPU interrupt is requested.

Table 7.8 lists the register information in block transfer mode and figure 7.8 shows the memory map in block transfer mode.

Table 7.8 Register Information in Block Transfer Mode

Name	Abbreviation	Function
DTC source address register	SAR	Designates transfer source address
DTC destination address register	DAR	Designates destination address
DTC transfer count register AH	CRAH	Holds block size
DTC transfer count register AL	CRAL	Block size counter
DTC transfer count register B	CRB	Transfer counter

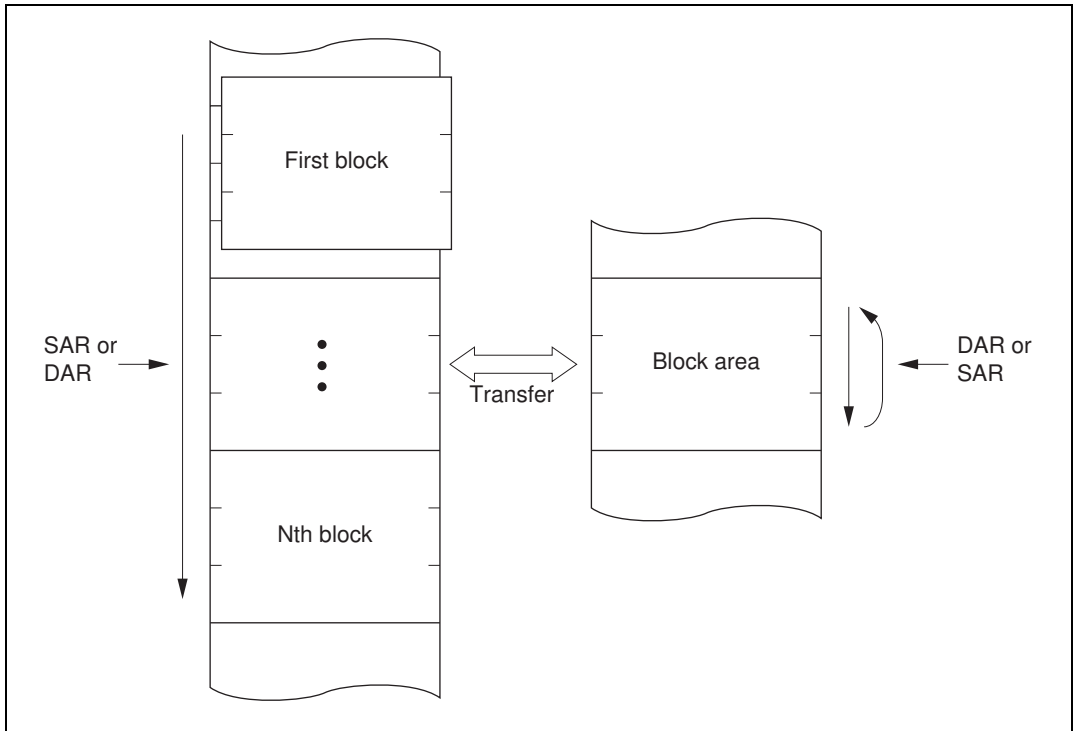

Figure 7.8 Memory Map in Block Transfer Mode

7.3.8 Chain Transfer

Setting the CHNE bit to 1 enables a number of data transfers to be performed consecutively in response to a single transfer request. It is also possible, by setting both the CHNE bit and CHNS bit to 1, to specify execution of chain transfer only when the transfer counter value is 0. SAR, DAR, CRA, CRB, MRA, and MRB, which define data transfers, can be set independently.

Figure 7.9 shows the memory map for chain transfer.

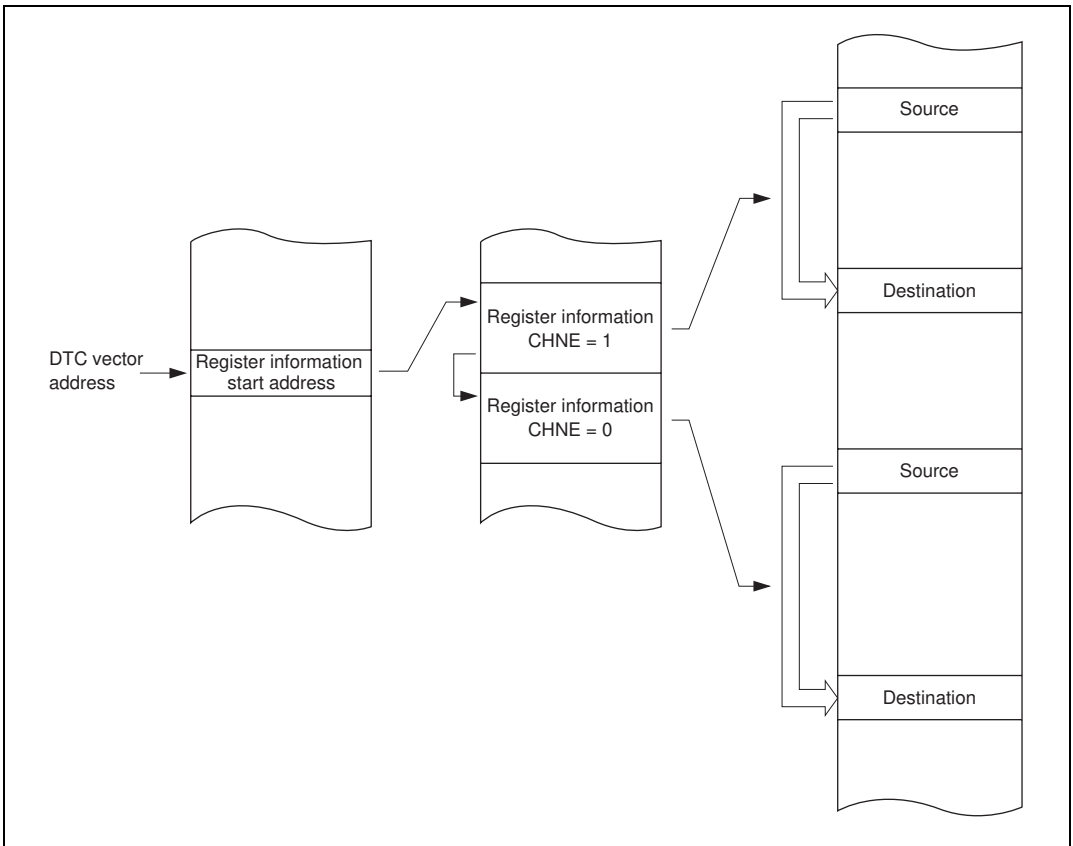

Figure 7.9 Chain Transfer Memory Map

In the case of transfer with CHNE set to 1, an interrupt request to the CPU is not generated at the end of the specified number of transfers or by setting of the DISEL bit to 1, and the interrupt source flag for the activation source is not affected.

7.3.9 Operation Timing

Figures 7.10 to 7.12 show examples of DTC operation timing.

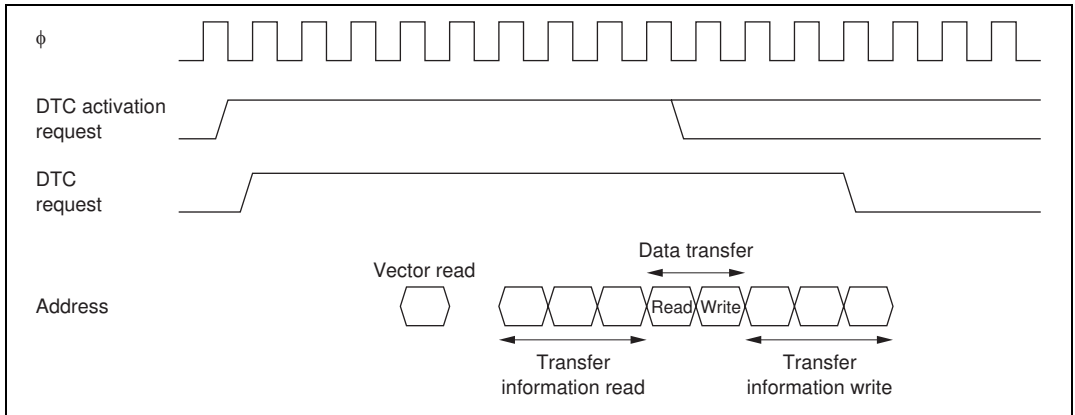

Figure 7.10 DTC Operation Timing (Example in Normal Mode or Repeat Mode)

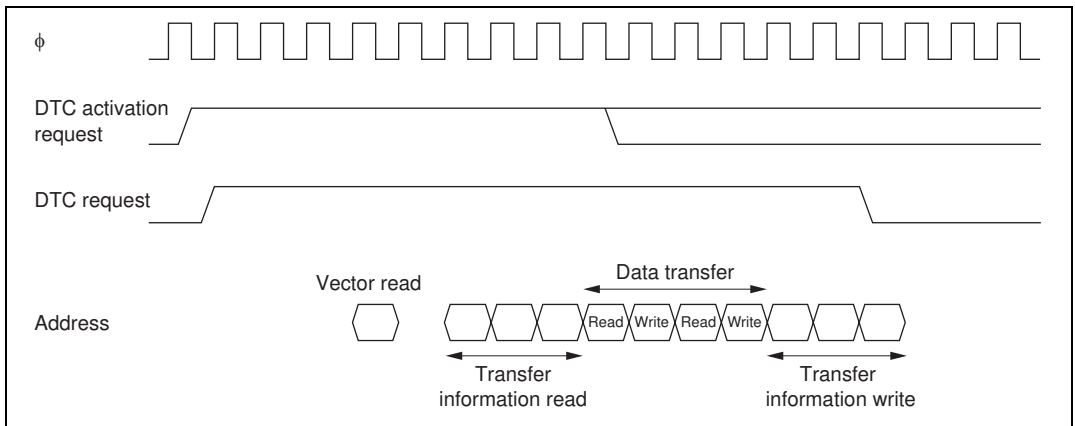

Figure 7.11 DTC Operation Timing (Example of Block Transfer Mode, with Block Size of 2)

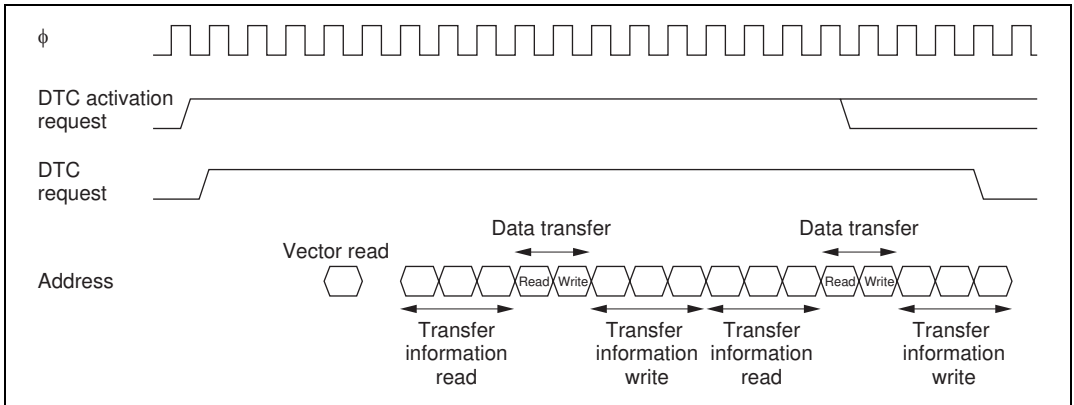

Figure 7.12 DTC Operation Timing (Example of Chain Transfer)

7.3.10 Number of DTC Execution States

Table 7.9 lists execution phases for a single DTC data transfer, and table 7.10 shows the number of states required for each execution phase.

Table 7.9 DTC Execution Phases

Mode	Register Information				
	Vector Read I	Read/Write J	Data Read K	Data Write L	Internal Operations M
Normal	1	6	1	1	3
Repeat	1	6	1	1	3
Block transfer	1	6	N	N	3

N: Block size (initial setting of CRAH and CRAL)

Table 7.10 Number of States Required for Each Execution Phase

Access To:		On-Chip RAM	On-Chip ROM	Internal I/O Registers		External Devices				
Bus width		32	16	8	16	8	8	16	16	
Access states		1	1	2	2	2	3	2	3	
Execution phase	Vector read	S _I	—	1	—	—	4	6+2m	2	3+m
	Register information read/write	S _J	1	—	—	—	—	—	—	—
	Byte data read	S _K	1	1	2	2	2	3+m	2	3+m
	Word data read	S _K	1	1	4	2	4	6+2m	2	3+m
	Byte data write	S _L	1	1	2	2	2	3+m	2	3+m
	Word data write	S _L	1	1	4	2	4	6+2m	2	3+m
	Internal operation	S _M	1	1	1	1	1	1	1	1

The number of execution states is calculated from the formula below. Note that Σ means the sum of all transfers activated by one activation event (the number in which the CHNE bit is set to 1, plus 1).

$$\text{Number of execution states} = I \cdot S_I + \Sigma (J \cdot S_J + K \cdot S_K + L \cdot S_L) + M \cdot S_M$$

For example, when the DTC vector address table is located in on-chip ROM, normal mode is set, and data is transferred from the on-chip ROM to an internal I/O register, the time required for the DTC operation is 13 states. The time from activation to the end of the data write is 10 states.

7.3.11 Procedures for Using DTC

Activation by Interrupt: The procedure for using the DTC with interrupt activation is as follows:

- [1] Set the MRA, MRB, SAR, DAR, CRA, and CRB register information in the on-chip RAM.
- [2] Set the start address of the register information in the DTC vector address.
- [3] Set the corresponding bit in DTCER to 1.
- [4] Set the enable bits for the interrupt sources to be used as the activation sources to 1. The DTC is activated when an interrupt used as an activation source is generated.
- [5] After the end of one data transfer, or after the specified number of data transfers have ended, the DTCE bit is cleared to 0 and a CPU interrupt is requested. If the DTC is to continue transferring data, set the DTCE bit to 1.

Activation by Software: The procedure for using the DTC with software activation is as follows:

- [1] Set the MRA, MRB, SAR, DAR, CRA, and CRB register information in the on-chip RAM.
- [2] Set the start address of the register information in the DTC vector address.
- [3] Check that the SWDTE bit is 0.
- [4] Write 1 to the SWDTE bit and the vector number to DTVECR.
- [5] Check the vector number written to DTVECR.
- [6] After the end of one data transfer, if the DISEL bit is 0 and a CPU interrupt is not requested, the SWDTE bit is cleared to 0. If the DTC is to continue transferring data, set the SWDTE bit to 1. When the DISEL bit is 1, or after the specified number of data transfers have ended, the SWDTE bit is held at 1 and a CPU interrupt is requested.

7.3.12 Examples of Use of the DTC

Normal Mode: An example is shown in which the DTC is used to receive 128 bytes of data via the SCI.

- [1] Set MRA to fixed source address ($SM1 = SM0 = 0$), incrementing destination address ($DM1 = 1$, $DM0 = 0$), normal mode ($MD1 = MD0 = 0$), and byte size ($Sz = 0$). The DTS bit can have any value. Set MRB for one data transfer by one interrupt ($CHNE = 0$, $DISEL = 0$). Set the SCI RDR address in SAR, the start address of the RAM area where the data will be received in DAR, and 128 (H'0080) in CRA. CRB can be set to any value.
- [2] Set the start address of the register information at the DTC vector address.
- [3] Set the corresponding bit in DT CER to 1.
- [4] Set the SCI to the appropriate receive mode. Set the RIE bit in SCR to 1 to enable the reception data full (RXI) interrupt. Since the generation of a receive error during the SCI receive operation will disable subsequent reception, the CPU should be enabled to accept receive error interrupts.
- [5] Each time reception of one byte of data ends on the SCI, the RDRF flag in SSR is set to 1, an RXI interrupt is generated, and the DTC is activated. The receive data is transferred from RDR to RAM by the DTC. DAR is incremented and CRA is decremented. The RDRF flag is automatically cleared to 0.
- [6] When CRA becomes 0 after the 128 data transfers have ended, the RDRF flag is held at 1, the DTCE bit is cleared to 0, and an RXI interrupt request is sent to the CPU. The interrupt handling routine should perform wrap-up processing.

Chain Transfer when Counter = 0: By executing a second data transfer, and performing re-setting of the first data transfer, only when the counter value is 0, it is possible to perform 256 or more repeat transfers.

An example is shown in which a 128-kbyte input buffer is configured. The input buffer is assumed to have been set to start at lower address H'0000. Figure 7.13 shows the memory map.

- [1] For the first transfer, set the normal mode for input data. Set fixed transfer source address (G/A, etc.), CRA = H'0000 (64k times), and CHNE = 1, CHNS = 1, and DISEL = 0.
- [2] Prepare the upper 8-bit addresses of the start addresses for each of the 64k transfer start addresses for the first data transfer in a separate area (in ROM, etc.). For example, if the input buffer comprises H'200000 to H'21FFFF, prepare H'21 and H'20.
- [3] For the second transfer, set repeat mode (with the source side as the repeat area) for re-setting the transfer destination address for the first data transfer. Use the upper 8 bits of DAR in the first register information area as the transfer destination. Set CHNE = DISEL = 0. If the above input buffer is specified as H'200000 to H'21FFFF, set the transfer counter to 2.
- [4] Execute the first data transfer 64k times by means of interrupts. When the transfer counter for the first data transfer reaches 0, the second data transfer is started. Set the upper 8 bits of the transfer source address for the first data transfer to H'21. The lower 16 bits of the transfer destination address of the first data transfer and the transfer counter are H'0000.
- [5] Next, execute the first data transfer the 64k times specified for the first data transfer by means of interrupts. When the transfer counter for the first data transfer reaches 0, the second data transfer is started. Set the upper 8 bits of the transfer source address for the first data transfer to H'20. The lower 16 bits of the transfer destination address of the first data transfer and the transfer counter are H'0000.
- [6] Steps [4] and [5] are repeated endlessly. As repeat mode is specified for the second data transfer, an interrupt request is not sent to the CPU.

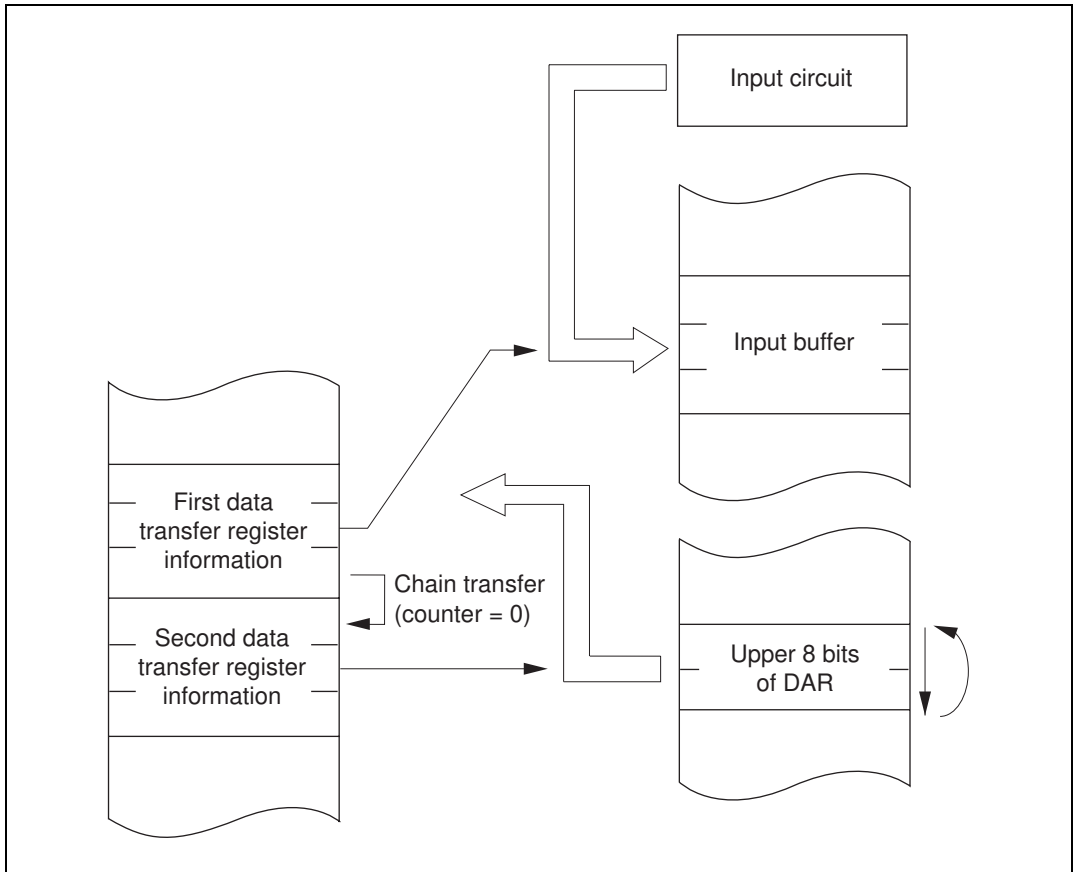

Figure 7.13 Chain Transfer when Counter = 0

Software Activation: An example is shown in which the DTC is used to transfer a block of 128 bytes of data by means of software activation. The transfer source address is H'1000 and the destination address is H'2000. The vector number is H'60, so the vector address is H'04C0.

- [1] Set MRA to incrementing source address (SM1 = 1, SM0 = 0), incrementing destination address (DM1 = 1, DM0 = 0), block transfer mode (MD1 = 1, MD0 = 0), and byte size (Sz = 0). The DTS bit can have any value. Set MRB for one block transfer by one interrupt (CHNE = 0). Set the transfer source address (H'1000) in SAR, the destination address (H'2000) in DAR, and 128 (H'8080) in CRA. Set 1 (H'0001) in CRB.
- [2] Set the start address of the register information at the DTC vector address (H'04C0).
- [3] Check that the SWDTE bit in DTVECR is 0. Check that there is currently no transfer activated by software.
- [4] Write 1 to the SWDTE bit and the vector number (H'60) to DTVECR. The write data is H'E0.
- [5] Read DTVECR again and check that it is set to the vector number (H'60). If it is not, this indicates that the write failed. This is presumably because an interrupt occurred between steps 3 and 4 and led to a different software activation. To activate this transfer, go back to step 3.
- [6] If the write was successful, the DTC is activated and a block of 128 bytes of data is transferred.
- [7] After the transfer, an SWDTEND interrupt occurs. The interrupt handling routine should clear the SWDTE bit to 0 and perform other wrap-up processing.

7.4 Interrupts

An interrupt request is issued to the CPU when the DTC finishes the specified number of data transfers, or a data transfer for which the DISEL bit was set to 1. In the case of interrupt activation, the interrupt set as the activation source is generated. These interrupts to the CPU are subject to CPU mask level and interrupt controller priority level control.

In the case of activation by software, a software activated data transfer end interrupt (SWDTEND) is generated.

When the DISEL bit is 1 and one data transfer has ended, or the specified number of transfers have ended, after data transfer ends, the SWDTE bit is held at 1 and an SWDTEND interrupt is generated. The interrupt handling routine should clear the SWDTE bit to 0.

When the DTC is activated by software, an SWDTEND interrupt is not generated during a data transfer wait or during data transfer even if the SWDTE bit is set to 1.

7.5 Usage Notes

Module Stop: When the MSTP14 bit in MSTPCR is set to 1, the DTC clock stops, and the DTC enters the module stop state. However, 1 cannot be written to the MSTP14 bit while the DTC is operating.

On-Chip RAM: The MRA, MRB, SAR, DAR, CRA, and CRB registers are all located in on-chip RAM. When the DTC is used, the RAME bit in SYSCR must not be cleared to 0.

DTCE Bit Setting: For DTCE bit setting, read/write operations must be performed using bit-manipulation instructions such as BSET and BCLR. For the initial setting only, however, when multiple activation sources are set at one time, it is possible to disable interrupts and write after executing a dummy read on the relevant register.

Chain Transfer: When chain transfer is used, clearing of the activation source or DTCER is performed when the last of the chain of data transfers is executed. SCI and A/D converter interrupt/activation sources, on the other hand, are cleared when the DTC reads or writes to the prescribed register.

Therefore, when the DTC is activated by an interrupt or activation source, if a read/write of the relevant register is not included in the last chained data transfer, the interrupt or activation source will be retained.

Section 8 I/O Ports

8.1 Overview

The H8S/2319 Group has 10 I/O ports (ports 1 to 3, and A to G), and one input-only port (port 4).

Table 8.1 summarizes the port functions. The pins of each port also have other functions.

Each port includes a data direction register (DDR) that controls input/output (not provided for the input-only ports), a data register (DR) that stores output data, and a port register (PORT) used to read the pin states.

Ports A to E have a built-in MOS pull-up function, and in addition to DR and DDR, have a MOS input pull-up control register (PCR) to control the on/off state of MOS input pull-up.

Port 3 and port A include an open drain control register (ODR) that controls the on/off state of the output buffer PMOS.

Ports 1, A to F can drive a single TTL load and 50-pF capacitive load, and ports 2, 3, and G can drive a single TTL load and 30-pF capacitive load.

Ports 1, 2, and ports 34, 35 (only when used as IRQ inputs), ports F0 to F3 (only when used as IRQ inputs), ports G0 and G1 (only when used as IRQ inputs) are schmitt-triggered inputs.

Table 8.1 Port Functions

Port	Description	Pins	Mode 4	Mode 5	Mode 6*1	Mode 7*1
Port 1	<ul style="list-style-type: none"> 8-bit I/O port Schmitt-triggered input 	P17/TIOCB2/TCLKD P16/TIOCA2 P15/TIOCB1/TCLKC P14/TIOCA1 P13/TIOCD0/TCLKB/A23 P12/TIOCC0/TCLKA/A22 P11/TIOCB0/A21 P10/TIOCA0/A20	8-bit I/O port also functioning as TPU I/O pins (TCLKA, TCLKB, TCLKC, TCLKD, TIOCA0, TIOCB0, TIOCC0, TIOCD0, TIOCA1, TIOCB1, TIOCA2, TIOCB2)			
			When DDR = 0: input port also functioning as TPU I/O pins (TCLKA, TCLKB, TIOCA0, TIOCB0, TIOCC0, TIOCD0) When DDR = 1 and A23E to A20E = 1: Address output When DDR = 1 and A23E to A20E = 0: DR value output			
Port 2	<ul style="list-style-type: none"> 8-bit I/O port Schmitt-triggered input 	P27/TIOCB5/TMO1 P26/TIOCA5/TMO0 P25/TIOCB4/TMCI1 P24/TIOCA4/TMRI1 P23/TIOCD3/TMCI0 P22/TIOCC3/TMRI0 P21/TIOCB3 P20/TIOCA3	8-bit I/O port also functioning as TPU I/O pins (TIOCA3, TIOCB3, TIOCC3, TIOCD3, TIOCA4, TIOCB4, TIOCA5, TIOCB5), and 8-bit timer (channels 0 and 1) I/O pins (TMRI0, TMCI0, TMO0, TMRI1, TMCI1, TMO1)			
Port 3	<ul style="list-style-type: none"> 6-bit I/O port Open-drain output capability Schmitt-triggered input (IRQ5, IRQ4) 	P35/SCK1/IRQ5 P34/SCK0/IRQ4 P33/RxD1 P32/RxD0 P31/TxD1 P30/TxD0	6-bit I/O port also functioning as SCI (channels 0 and 1) I/O pins (TxD0, RxD0, SCK0, TxD1, RxD1, SCK1) and interrupt input pins (IRQ5, IRQ4)			

Port	Description	Pins	Mode 4	Mode 5	Mode 6*1	Mode 7*1
Port 4	• 8-bit input port	P47/AN7/DA1 P46/AN6/DA0 P45/AN5 P44/AN4 P43/AN3 P42/AN2 P41/AN1 P40/AN0	8-bit input port also functioning as A/D converter analog inputs (AN7 to AN0) and D/A converter analog outputs (DA1 and DA0)			
Port A	• 4-bit I/O port • Built-in MOS input pull-up • Open-drain output capability	PA3/A19 to PA0/A16	Address output		When DDR = 0 (after reset): input ports When DDR = 1: address output	I/O port
Port B	• 8-bit I/O port • Built-in MOS input pull-up	PB7/A15 to PB0/A8	Address output		When DDR = 0 (after reset): input port When DDR = 1: address output	I/O port
Port C	• 8-bit I/O port • Built-in MOS input pull-up	PC7/A7 to PC0/A0	Address output		When DDR = 0 (after reset): input port When DDR = 1: address output	I/O port
Port D	• 8-bit I/O port • Built-in MOS input pull-up	PD7/D15 to PD0/D8	Data bus input/output			I/O port

Port	Description	Pins	Mode 4	Mode 5	Mode 6*1	Mode 7*1
Port E	<ul style="list-style-type: none"> 8-bit I/O port Built-in MOS input pull-up 	PE7/D7 to PE0/D0	In 8-bit bus mode: I/O port In 16-bit bus mode: data bus input/output			I/O port
Port F	<ul style="list-style-type: none"> 8-bit I/O port Schmitt-triggered input (IRQ3 to IRQ0) 	PF7/ ϕ	When DDR = 0: input port When DDR = 1 (after reset): ϕ output			When DDR = 0 (after reset): input port When DDR = 1: ϕ output
		PF6/ \overline{AS}	When ASOD = 1: I/O port When ASOD = 0: \overline{AS} output			I/O port
		PF5/ \overline{RD} PF4/HWR	RD, HWR output			
		PF3/ \overline{LWR} /IRQ3	In 8-bit bus mode: When LWROD = 1, I/O port In 16-bit bus mode: \overline{LWR} output also functioning as interrupt input pin (IRQ3)			I/O port also functioning as interrupt input pins (IRQ3 to IRQ0)
		PF2/ \overline{WAIT} /IRQ2/ \overline{BREQO}	When WAITE = 0, BRLE = 0, BREQOE = 0 (after reset): I/O port also functioning as interrupt input pin (IRQ2)			
			When WAITE = 1: \overline{WAIT} input also functioning as interrupt input pin (IRQ2)			
When WAITE = 0, BRLE = 1, BREQOE = 1: \overline{BREQO} output also functioning as interrupt input pin (IRQ2)						
PF1/ \overline{BACK} /IRQ1/ $\overline{CS5}$ PF0/ \overline{BREQ} /IRQ0/ $\overline{CS4}$	When BRLE = 0 (after reset): I/O port also functioning as interrupt input pins ($\overline{IRQ1}$, $\overline{IRQ0}$) When CS25E = 1, PF1CS5S = 1, and DDR = 1: Also functions as $\overline{CS5}$ output When CS25E = 1, PF0CS4S = 1, and DDR = 1: Also functions as $\overline{CS4}$ output When BRLE = 1: \overline{BREQ} input, \overline{BACK} output also functioning as interrupt input pins (IRQ1, IRQ0)					

Port	Description	Pins	Mode 4	Mode 5	Mode 6*1	Mode 7*1
Port G	<ul style="list-style-type: none"> 5-bit I/O port Schmitt-triggered input (IRQ7, IRQ6) 	PG4/ $\overline{CS0}$	When DDR = 0*2: input port When DDR = 1*3: $\overline{CS0}$ output			I/O port also functions as interrupt input pins (IRQ7, IRQ6) and A/D converter input pin (ADTRG)
		PG3/ $\overline{CS1}/\overline{CS7}$	I/O port When DDR = 1, CS167E = 1, and CSS17 = 0: Also functions as $\overline{CS1}$ output When DDR = 1, CS167E = 1, and CSS17 = 1: Also functions as $\overline{CS7}$ output			
		PG2/ $\overline{CS2}$	I/O port When DDR = 1 and CS25E = 1: Also functions as $\overline{CS2}$ output			
		PG1/ $\overline{CS3}/\overline{IRQ7}/\overline{CS6}$	I/O port When DDR = 1, CS25E = 1, and CSS36 = 0: Also functions as $\overline{CS3}$ output When DDR = 1, CSS36 = 1, and CS167E = 1: Also functions as $\overline{CS6}$ output and interrupt input pin (IRQ7)			
		PG0/ $\overline{IRQ6}/\overline{ADTRG}$	I/O port also functioning as interrupt input pin ($\overline{IRQ6}$) and A/D converter input pin (ADTRG)			

- Notes:
1. Modes 6 and 7 are not available in the ROMless versions.
 2. After a reset in mode 6
 3. After a reset in mode 4 or 5

8.2 Port 1

8.2.1 Overview

Port 1 is an 8-bit I/O port. Port 1 pins also function as TPU I/O pins (TCLKA, TCLKB, TCLKC, TCLKD, TIOCA0, TIOCB0, TIOCC0, TIOCD0, TIOCA1, TIOCB1, TIOCA2, and TIOCB2) and an address bus output function. Port 1 pin functions change according to the operating mode. The address output or port output function is selected according to the settings of bits A23E to A20E in PFCR1. Port 1 pins have Schmitt-trigger inputs.

Figure 8.1 shows the port 1 pin configuration.

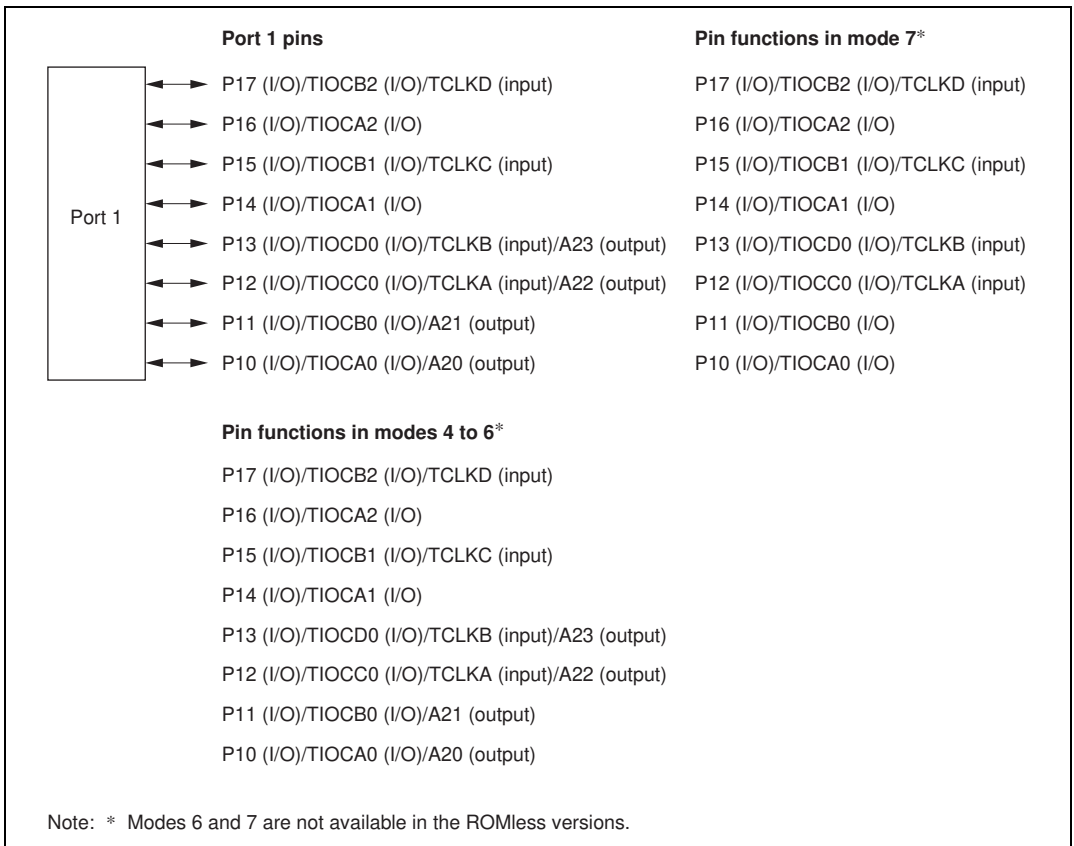

Figure 8.1 Port 1 Pin Functions

8.2.2 Register Configuration

Table 8.2 shows the port 1 register configuration.

Table 8.2 Port 1 Registers

Name	Abbreviation	R/W	Initial Value	Address*
Port 1 data direction register	P1DDR	W	H'00	H'FE80
Port 1 data register	P1DR	R/W	H'00	H'FF60
Port 1 register	PORT1	R	Undefined	H'FF50
Port function control register 1	PFCR1	R/W	H'0F	H'FF45

Note: * Lower 16 bits of the address.

Port 1 Data Direction Register (P1DDR)

Bit	:	7	6	5	4	3	2	1	0
		P17DDR	P16DDR	P15DDR	P14DDR	P13DDR	P12DDR	P11DDR	P10DDR
Initial value	:	0	0	0	0	0	0	0	0
R/W	:	W	W	W	W	W	W	W	W

P1DDR is an 8-bit write-only register, the individual bits of which specify input or output for the pins of port 1. P1DDR cannot be read; if it is, an undefined value will be read.

Setting a P1DDR bit to 1 makes the corresponding port 1 pins output pins, while clearing the bit to 0 makes the pins input pins.

P1DDR is initialized to H'00 by a reset, and in hardware standby mode. It retains its prior state in software standby mode.

Whether the address output pins maintain their output state or go to the high-impedance state in a transition to software standby mode is selected by the OPE bit in SBYCR.

Port 1 Data Register (P1DR)

Bit	:	7	6	5	4	3	2	1	0
		P17DR	P16DR	P15DR	P14DR	P13DR	P12DR	P11DR	P10DR
Initial value	:	0	0	0	0	0	0	0	0
R/W	:	R/W	R/W	R/W	R/W	R/W	R/W	R/W	R/W

P1DR is an 8-bit readable/writable register that stores output data for the port 1 pins (P17 to P10).

P1DR is initialized to H'00 by a reset, and in hardware standby mode. It retains its prior state in software standby mode.

Port 1 Register (PORT1)

Bit	:	7	6	5	4	3	2	1	0
		P17	P16	P15	P14	P13	P12	P11	P10
Initial value	:	—*	—*	—*	—*	—*	—*	—*	—*
R/W	:	R	R	R	R	R	R	R	R

Note: *Determined by state of pins P17 to P10.

PORT1 is an 8-bit read-only register that shows the pin states. It cannot be written to. Writing of output data for the port 1 pins (P17 to P10) must always be performed on P1DR.

If a port 1 read is performed while P1DDR bits are set to 1, the P1DR values are read. If a port 1 read is performed while P1DDR bits are cleared to 0, the pin states are read.

After a reset and in hardware standby mode, PORT1 contents are determined by the pin states, as P1DDR and P1DR are initialized. PORT1 retains its prior state in software standby mode.

Port Function Control Register 1 (PFCR1)

Bit	:	7	6	5	4	3	2	1	0
		CSS17	CSS36	PF1CS5S	PF0CS4S	A23E	A22E	A21E	A20E
Initial value	:	0	0	0	0	1	1	1	1
R/W	:	R/W	R/W	R/W	R/W	R/W	R/W	R/W	R/W

PFCR1 is an 8-bit readable/writable register that performs I/O port control. PFCR1 is initialized to H'0F by a reset, and in hardware standby mode.

Bit 7—CS17 Select (CSS17): Selects whether $\overline{CS1}$ or $\overline{CS7}$ is output from the PG3 pin. For details, see section 8.12, Port G.

Bit 6—CS36 Select (CSS36): Selects whether $\overline{CS3}$ or $\overline{CS6}$ is output from the PG1 pin. For details, see section 8.12, Port G.

Bit 5—Port F1 Chip Select 5 Select (PF1CS5S): Selects enabling or disabling of $\overline{CS5}$ output. For details, see section 8.11, Port F.

Bit 4—Port F0 Chip Select 4 Select (PF0CS4S): Selects enabling or disabling of $\overline{CS4}$ output. For details, see section 8.11, Port F.

Bit 3—Address 23 Enable (A23E): Enables or disables address output 23 (A23). This bit is valid in modes 4 to 6.

Bit 3

A23E	Description
0	P13DR is output when P13DDR = 1
1	A23 is output when P13DDR = 1 (Initial value)

Bit 2—Address 22 Enable (A22E): Enables or disables address output 22 (A22). This bit is valid in modes 4 to 6.

Bit 2

A22E	Description
0	P12DR is output when P12DDR = 1
1	A22 is output when P12DDR = 1 (Initial value)

Bit 1—Address 21 Enable (A21E): Enables or disables address output 21 (A21). This bit is valid in modes 4 to 6.

Bit 1

A21E	Description
0	P11DR is output when P11DDR = 1
1	A21 is output when P11DDR = 1 (Initial value)

Bit 0—Address 20 Enable (A20E): Enables or disables address output 20 (A20). This bit is valid in modes 4 to 6.

Bit 0

A20E	Description
0	P10DR is output when P10DDR = 1
1	A20 is output when P10DDR = 1 (Initial value)

8.2.3 Pin Functions

Port 1 pins also function as TPU I/O pins (TCLKA, TCLKB, TCLKC, TCLKD, TIOCA0, TIOCB0, TIOCC0, TIOCD0, TIOCA1, TIOCB1, TIOCA2, and TIOCB2) and address output pins (A23 to A20). Port 1 pin functions are shown in table 8.3.

Table 8.3 Port 1 Pin Functions

Pin	Selection Method and Pin Functions		
P17/TIOCB2/ TCLKD	The pin function is switched as shown below according to the combination of the TPU channel 2 setting by bits MD3 to MD0 in TMDR2, bits IOB3 to IOB0 in TIOR2, bits CCLR1 and CCLR0 in TCR2, bits TPSC2 to TPSC0 in TCR0 and TCR5, and bit P17DDR.		
TPU Channel 2 Setting	Table Below (1)	Table Below (2)	
P17DDR	—	0	1
Pin function	TIOCB2 output	P17 input	P17 output
		TIOCB2 input *1	
TCLKD input *2			

TPU Channel 2 Setting	(2)	(1)	(2)	(2)	(1)	(2)
MD3 to MD0	B'0000, B'01xx		B'0010	B'0011		
IOB3 to IOB0	B'0000 B'0100 B'1xxx	B'0001 to B'0011 B'0101 to B'0111	—	B'xx00	Other than B'xx00	
CCLR1, CCLR0	—	—	—	—	Other than B'10	B'10
Output function	—	Output compare output	—	—	PWM mode 2 output	—

x: Don't care

- Notes: 1. TIOCB2 input when MD3 to MD0 = B'0000 or B'01xx and IOB3 = 1.
 2. TCLKD input when the setting for either TCR0 or TCR5 is: TPSC2 to TPSC0 = B'111.
 TCLKD input when channels 2 and 4 are set to phase counting mode (MD3 to MD0 = B'01xx).

Pin Selection Method and Pin Functions

P16/TIOCA2 The pin function is switched as shown below according to the combination of the TPU channel 2 setting by bits MD3 to MD0 in TMDR2, bits IOA3 to IOA0 in TIOR2, bits CCLR1 and CCLR0 in TCR2, and bit P16DDR.

TPU Channel 2 Setting	Table Below (1)	Table Below (2)	
P16DDR	—	0	1
Pin function	TIOCA2 output	P16 input	P16 output
		TIOCA2 input ^{*1}	

TPU Channel 2 Setting	(2)	(1)	(2)	(1)	(1)	(2)
MD3 to MD0	B'0000, B'01xx		B'001x	B'0011	B'0011	
IOA3 to IOA0	B'0000 B'0100 B'1xxx	B'0001 to B'0011 B'0101 to B'0111	B'xx00	Other than B'xx00		
CCLR1, CCLR0	—	—	—	—	Other than B'01	B'01
Output function	—	Output compare output	—	PWM mode 1 output ^{*2}	PWM mode 2 output	—

x: Don't care

- Notes: 1. TIOCA2 input when MD3 to MD0 = B'0000 or B'01xx and IOA3 = 1.
2. TIOCB2 output is disabled.

Pin Selection Method and Pin Functions

P15/TIOCB1/
TCLKC

The pin function is switched as shown below according to the combination of the TPU channel 1 setting by bits MD3 to MD0 in TMDR1, bits IOB3 to IOB0 in TIOR1, bits CCLR1 and CCLR0 in TCR1, bits TPSC2 to TPSC0 in TCR0, TCR2, TCR4, and TCR5, and bit P15DDR.

TPU Channel 1 Setting	Table Below (1)	Table Below (2)	
P15DDR	—	0	1
Pin function	TIOCB1 output	P15 input	P15 output
		TIOCB1 input *1	
TCLKC input *2			

TPU Channel 1 Setting	(2)	(1)	(2)	(2)	(1)	(2)
MD3 to MD0	B'0000, B'01xx		B'0010	B'0011		
IOB3 to IOB0	B'0000 B'0100 B'1xxx	B'0001 to B'0011 B'0101 to B'0111	—	B'xx00	Other than B'xx00	
CCLR1, CCLR0	—	—	—	—	Other than B'10	B'10
Output function	—	Output compare output	—	—	PWM mode 2 output	—

x: Don't care

- Notes: 1. TIOCB1 input when MD3 to MD0 = B'0000 or B'01xx and IOB3 to IOB0 = B'10xx.
2. TCLKC input when the setting for either TCR0 or TCR2 is: TPSC2 to TPSC0 = B'110; or when the setting for either TCR4 or TCR5 is TPSC2 to TPSC0 = B'101.
TCLKC input when channels 2 and 4 are set to phase counting mode (MD3 to MD0 = B'01xx).

Pin Selection Method and Pin Functions

P14/TIOCA1 The pin function is switched as shown below according to the combination of the TPU channel 1 setting by bits MD3 to MD0 in TMDR1, bits IOA3 to IOA0 in TIOR1, bits CCLR1 and CCLR0 in TCR1, and bit P14DDR.

TPU Channel 1 Setting	Table Below (1)	Table Below (2)	
P14DDR	—	0	1
Pin function	TIOCA1 output	P14 input	P14 output
		TIOCA1 input ^{*1}	

TPU Channel 1 Setting	(2)	(1)	(2)	(1)	(1)	(2)
MD3 to MD0	B'0000, B'01xx		B'001x	B'0010	B'0011	
IOA3 to IOA0	B'0000 B'0100 B'1xxx	B'0001 to B'0011 B'0101 to B'0111	B'xx00	Other than B'xx00		
CCLR1, CCLR0	—	—	—	—	Other than B'01	B'01
Output function	—	Output compare output	—	PWM mode 1 output ^{*2}	PWM mode 2 output	—

×: Don't care

- Notes: 1. TIOCA1 input when MD3 to MD0 = B'0000 or B'01xx and IOA3 to IOA0 = B'10xx.
2. TIOCB1 output is disabled.

Pin Selection Method and Pin Functions

P13/TIOCD0/
TCLKB/A23

The pin function is switched as shown below according to the combination of the operating mode, TPU channel 0 setting (by bits MD3 to MD0 in TMDR0, bits IOD3 to IOD0 in TIOR0L, and bits CCLR2 to CCLR0 in TCR0), bits TPSC2 to TPSC0 in TCR0 to TCR2, bit A23E in PFCR1, and bit P13DDR.

Operating Mode	Mode 7*1			Modes 4 to 6*1					
	Table Below (1)		Table Below (2)	Table Below (1)			Table Below (2)		
P13DDR	—	0	1	0	1		0	1	
A23E	—	—	—	—	0	1	—	0	1
Pin function	TIOCD0 output	P13 input	P13 output	TIOCD0 output	TIOCD0 output	A23 output	P13 input	P13 output	A23 output
		TIOCD0 input*2					TIOCD0 input*2		
	TCLKB input*3								

TPU Channel 0 Setting	(2)	(1)	(2)	(2)	(1)	(2)
MD3 to MD0	B'0000		B'0010	B'0011		
IOD3 to IOD0	B'0000 B'0100 B'1xxx	B'0001 to B'0011 B'0101 to B'0111	—	B'xx00	Other than B'xx00	
CCLR2 to CCLR0	—	—	—	—	Other than B'110	B'110
Output function	—	Output compare output	—	—	PWM mode 2 output	—

x: Don't care

- Notes:
- Modes 6 and 7 are not available in the ROMless versions.
 - TIOCD0 input when MD3 to MD0 = B'0000 and IOD3 to IOD0 = B'10xx.
 - TCLKB input when the TCR0, TCR1, or TCR2 setting is: TPSC2 to TPSC0 = B'101.
TCLKB input when channels 1 and 5 are set to phase counting mode (MD3 to MD0 = B'01xx).

Pin Selection Method and Pin Functions

P12/TIOCC0/
TCLKA/A22

The pin function is switched as shown below according to the combination of the operating mode, TPU channel 0 setting (by bits MD3 to MD0 in TMDR0, bits IOC3 to IOC0 in TIOR0L, and bits CCLR2 to CCLR0 in TCR0), bits TPSC2 to TPSC0 in TCR0 to TCR5, bit A22E in PFCR1 and bit P12DDR.

Operating Mode	Mode 7*1			Modes 4 to 6*1					
	Table Below (1)		Table Below (2)	Table Below (1)			Table Below (2)		
P12DDR	—	0	1	0	1		0	1	
A22E	—	—	—	—	0	1	—	0	1
Pin function	TIOCC0 output	P12 input	P12 output	TIOCC0 output	TIOCC0 output	A22 output	P12 input	P12 output	A22 output
		TIOCC0 input*2					TIOCC0 input*2		
	TCLKA input*3								

TPU Channel 0 Setting	(2)	(1)	(2)	(1)	(1)	(2)
MD3 to MD0	B'0000		B'001×	B'0010	B'0011	
IOC3 to IOC0	B'0000 B'0100 B'1×××	B'0001 to B'0011 B'0101 to B'0111	B'××00	Other than B'××00		
CCLR2 to CCLR0	—	—	—	—	Other than B'101	B'101
Output function	—	Output compare output	—	PWM mode 1 output*4	PWM mode 2 output	—

×: Don't care

- Notes:
- Modes 6 and 7 are not available in the ROMless versions.
 - TIOCC0 input when MD3 to MD0 = B'0000 and IOC3 to IOC0 = B'10××.
 - TCLKA input when the TCR0 to TCR5 setting is: TPSC2 to TPSC0 = B'100.
TCLKA input when channel 1 and 5 are set to phase counting mode (MD3 to MD0 = B'01××).
 - TIOCC0 output is disabled.
When BFA = 1 or BFB = 1 in TMDR0, output is disabled and setting (2) applies.

Pin Selection Method and Pin Functions

P11/TIOCB0/
A21

The pin function is switched as shown below according to the combination of the operating mode, TPU channel 0 setting (by bits MD3 to MD0 in TMDR0, bits IOB3 to IOB0 in TIOR0H, and bits CCLR2 to CCLR0 in TCR0), bit A21E in PFCR1 and bit P11DDR.

Operating Mode	Mode 7* ¹			Modes 4 to 6* ¹					
	Table Below (1)	Table Below (2)		Table Below (1)			Table Below (2)		
P11DDR	—	0	1	0	1		0	1	
A21E	—	—	—	—	0	1	—	0	1
Pin function	TIOCB0 output	P11 input	P11 output	TIOCB0 output	TIOCB0 output	A21 output	P11 input	P11 output	A21 output
		TIOCB0 input* ²					TIOCB0 input* ²		

TPU Channel 0 Setting	(2)	(1)	(2)	(2)	(1)	(2)
MD3 to MD0	B'0000		B'0010	B'0011		
IOB3 to IOB0	B'0000 B'0100 B'1xxx	B'0001 to B'0011 B'0101 to B'0111	—	B'xx00	Other than B'xx00	
CCLR2 to CCLR0	—	—	—	—	Other than B'010	B'010
Output function	—	Output compare output	—	—	PWM mode 2 output	—

x: Don't care

Notes: 1. Modes 6 and 7 are not available in the ROMless versions.

2. TIOCB0 input when MD3 to MD0 = B'0000 and IOB3 to IOB0 = B'10xx.

Pin Selection Method and Pin FunctionsP10/TIOCA0/
A20

The pin function is switched as shown below according to the combination of the operating mode, TPU channel 0 setting (by bits MD3 to MD0 in TMDR0, bits IOA3 to IOA0 in TIOR0H, and bits CCLR2 to CCLR0 in TCR0), bit A20E in PFCR1 and bit P10DDR.

Operating Mode	Mode 7*1			Modes 4 to 6*1					
	Table Below (1)		Table Below (2)	Table Below (1)			Table Below (2)		
TPU Channel 0 Setting	—		0	0	1		0	1	
P10DDR	—		0	—	0	1	—	0	1
A20E	—		—	—	0	1	—	0	1
Pin function	TIOCA0 output	P10 input	P10 output	TIOCA0 output	TIOCA0 output	A20 output	P10 input	P10 output	A20 output
		TIOCA0 input*2						TIOCA0 input*2	

TPU Channel 0 Setting	(2)	(1)	(2)	(1)	(1)	(2)
MD3 to MD0	B'0000		B'001×	B'0010	B'0011	
IOA3 to IOA0	B'0000 B'0100 B'1×××	B'0001 to B'0011 B'0101 to B'0111	B'××00	Other than B'××00		
CCLR2 to CCLR0	—	—	—	—	Other than B'001	B'001
Output function	—	Output compare output	—	PWM mode 1 output*3	PWM mode 2 output	—

×: Don't care

- Notes:
- Modes 6 and 7 are not available in the ROMless versions.
 - TIOCA0 input when MD3 to MD0 = B'0000 and IOA3 to IOA0 = B'10××.
 - TIOCB0 output is disabled.

8.3 Port 2

8.3.1 Overview

Port 2 is an 8-bit I/O port. Port 2 pins also function as TPU I/O pins (TIOCA3, TIOCB3, TIOCC3, TIOCD3, TIOCA4, TIOCB4, TIOCA5, and TIOCB5), and 8-bit timer I/O pins (TMRI0, TMCI0, TMO0, TMRI1, TMCI1, and TMO1). Port 2 pin functions are the same in all operating modes. Port 2 uses Schmitt-triggered input.

Figure 8.2 shows the port 2 pin configuration.

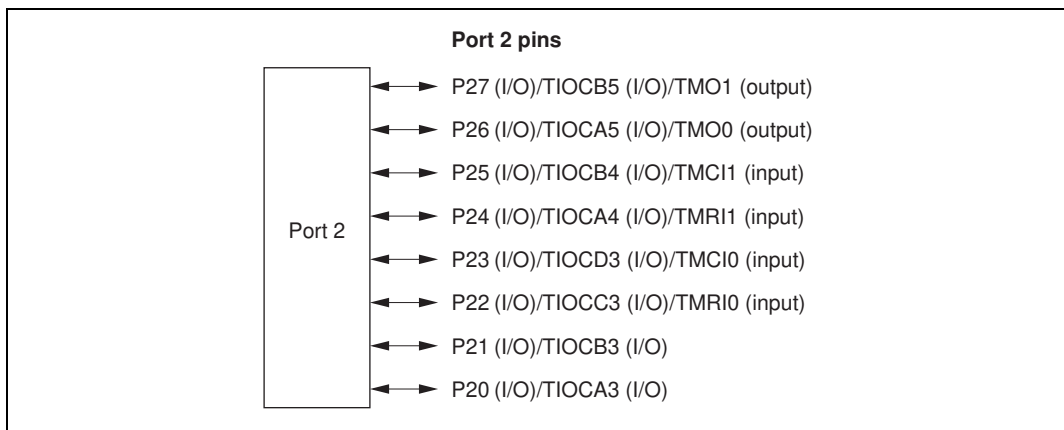

Figure 8.2 Port 2 Pin Functions

8.3.2 Register Configuration

Table 8.4 shows the port 2 register configuration.

Table 8.4 Port 2 Registers

Name	Abbreviation	R/W	Initial Value	Address*
Port 2 data direction register	P2DDR	W	H'00	H'FEB1
Port 2 data register	P2DR	R/W	H'00	H'FF61
Port 2 register	PORT2	R	Undefined	H'FF51

Note: * Lower 16 bits of the address.

Port 2 Data Direction Register (P2DDR)

Bit	:	7	6	5	4	3	2	1	0
		P27DDR	P26DDR	P25DDR	P24DDR	P23DDR	P22DDR	P21DDR	P20DDR
Initial value	:	0	0	0	0	0	0	0	0
R/W	:	W	W	W	W	W	W	W	W

P2DDR is an 8-bit write-only register, the individual bits of which specify input or output for the pins of port 2. P2DDR cannot be read; if it is, an undefined value will be read.

Setting P2DDR bits to 1 makes the corresponding port 2 pins output pins, while clearing the bits to 0 makes the pins input pins.

P2DDR is initialized to H'00 by a reset, and in hardware standby mode. It retains its prior state in software standby mode.

Port 2 Data Register (P2DR)

Bit	:	7	6	5	4	3	2	1	0
		P27DR	P26DR	P25DR	P24DR	P23DR	P22DR	P21DR	P20DR
Initial value	:	0	0	0	0	0	0	0	0
R/W	:	R/W	R/W	R/W	R/W	R/W	R/W	R/W	R/W

P2DR is an 8-bit readable/writable register that stores output data for the port 2 pins (P27 to P20).

P2DR is initialized to H'00 by a reset, and in hardware standby mode. It retains its prior state in software standby mode.

Port 2 Register (PORT2)

Bit	:	7	6	5	4	3	2	1	0								
		<table border="1"> <tr> <td>P27</td> <td>P26</td> <td>P25</td> <td>P24</td> <td>P23</td> <td>P22</td> <td>P21</td> <td>P20</td> </tr> </table>								P27	P26	P25	P24	P23	P22	P21	P20
P27	P26	P25	P24	P23	P22	P21	P20										
Initial value	:	—*	—*	—*	—*	—*	—*	—*	—*								
R/W	:	R	R	R	R	R	R	R	R								

Note: * Determined by state of pins P27 to P20.

PORT2 is an 8-bit read-only register that shows the pin states. It cannot be written to. Writing of output data for the port 2 pins (P27 to P20) must always be performed on P2DR.

If a port 2 read is performed while P2DDR bits are set to 1, the P2DR values are read. If a port 2 read is performed while P2DDR bits are cleared to 0, the pin states are read.

After a reset and in hardware standby mode, PORT2 contents are determined by the pin states, as P2DDR and P2DR are initialized. PORT2 retains its prior state in software standby mode.

8.3.3 Pin Functions

Port 2 pins also function as TPU I/O pins (TIOCA3, TIOCB3, TIOCC3, TIOCD3, TIOCA4, TIOCB4, TIOCA5, and TIOCB5), and 8-bit timer I/O pins (TMRI0, TMCI0, TMO0, TMRI1, TMCI1, and TMO1). Port 2 pin functions are shown in table 8.5.

Table 8.5 Port 2 Pin Functions

Pin	Selection Method and Pin Functions
-----	------------------------------------

P27/TIOCB5/ TMO1	The pin function is switched as shown below according to the combination of the TPU channel 5 setting by bits MD3 to MD0 in TMDR5, bits IOB3 to IOB0 in TIOR5, bits CCLR1 and CCLR0 in TCR5, bits OS3 to OS0 in TCSR1, and bit P27DDR.
---------------------	--

OS3 to OS0	All 0			Any 1
TPU Channel 5 Setting	Table Below (1)	Table Below (2)		—
P27DDR	—	0	1	—
Pin function	TIOCB5 output	P27 input	P27 output	TMO1 output
		TIOCB5 input *		

TPU Channel 5 Setting	(2)	(1)	(2)	(2)	(1)	(2)
MD3 to MD0	B'0000, B'01xx		B'0010	B'0011		
IOB3 to IOB0	B'0000 B'0100 B'1xxx	B'0001 to B'0011 B'0101 to B'0111	—	B'xx00	Other than B'xx00	
CCLR1, CCLR0	—	—	—	—	Other than B'10	B'10
Output function	—	Output compare output	—	—	PWM mode 2 output	—

×: Don't care

Note: * TIOCB5 input when MD3 to MD0 = B'0000 or B'01xx and IOB3 = 1.

Pin Selection Method and Pin Functions
**P26/TIOCA5/
TMO0**

The pin function is switched as shown below according to the combination of the TPU channel 5 setting by bits MD3 to MD0 in TMDR5, bits IOA3 to IOA0 in TIOR5, bits CCLR1 and CCLR0 in TCR5, bits OS3 to OS0 in TCSR0, and bit P26DDR.

OS3 to OS0	All 0			Any 1
TPU Channel 5 Setting	Table Below (1)	Table Below (2)		—
P26DDR	—	0	1	—
Pin function	TIOCA5 output	P26 input	P26 output	TMO0 output
		TIOCA5 input ^{*1}		

TPU Channel 5 Setting	(2)	(1)	(2)	(1)	(1)	(2)
MD3 to MD0	B'0000, B'01xx		B'001x	B'0010	B'0011	
IOA3 to IOA0	B'0000 B'0100 B'1xxx	B'0001 to B'0011 B'0101 to B'0111	B'xx00	Other than B'xx00		
CCLR1, CCLR0	—	—	—	—	Other than B'01	B'01
Output function	—	Output compare output	—	PWM mode 1 output ^{*2}	PWM mode 2 output	—

x: Don't care

- Notes: 1. TIOCA5 input when MD3 to MD0 = B'0000 or B'01xx and IOA3 = 1.
2. TIOCB5 output is disabled.

Pin Selection Method and Pin FunctionsP25/TIOCB4/
TMC11

This pin is used as the 8-bit timer external clock input pin when external clock is selected with bits CKS2 to CKS0 in TCR1.

The pin function is switched as shown below according to the combination of the TPU channel 4 setting by bits MD3 to MD0 in TMDR4 and bits IOB3 to IOB0 in TIOR4, bits CCLR1 and CCLR0 in TCR4, and bit P25DDR.

TPU Channel 4 Setting	Table Below (1)	Table Below (2)	
P25DDR	—	0	1
Pin function	TIOCB4 output	P25 input	P25 output
		TIOCB4 input *	
TMC11 input			

TPU Channel 4 Setting	(2)	(1)	(2)	(2)	(1)	(2)
MD3 to MD0	B'0000, B'01xx		B'0010	B'0011		
IOB3 to IOB0	B'0000 B'0100 B'1xxx	B'0001 to B'0011 B'0101 to B'0111	—	B'xx00	Other than B'xx00	
CCLR1, CCLR0	—	—	—	—	Other than B'10	B'10
Output function	—	Output compare output	—	—	PWM mode 2 output	—

x: Don't care

Note: *TIOCB4 input when MD3 to MD0 = B'0000 or B'10xx and IOB3 to IOB0 = B'10xx.

Pin Selection Method and Pin Functions

P24/TIOCA4/
TMRI1

This pin is used as the 8-bit timer counter reset pin when bits CCLR1 and CCLR0 in TCR1 are both set to 1.
The pin function is switched as shown below according to the combination of the TPU channel 4 setting by bits MD3 to MD0 in TMDR4, bits IOA3 to IOA0 in TIOR4, bits CCLR1 and CCLR0 in TCR4, and bit P24DDR.

TPU Channel 4 Setting	Table Below (1)	Table Below (2)	
P24DDR	—	0	1
Pin function	TIOCA4 output	P24 input	P24 output
		TIOCA4 input *1	
TMRI1 input			

TPU Channel 4 Setting	(2)	(1)	(2)	(1)	(1)	(2)
MD3 to MD0	B'0000, B'01xx		B'001x	B'0010	B'0011	
IOA3 to IOA0	B'0000 B'0100 B'1xxx	B'0001 to B'0011 B'0101 to B'0111	B'xx00	Other than B'xx00		
CCLR1, CCLR0	—	—	—	—	Other than B'01	B'01
Output function	—	Output compare output	—	PWM mode 1 output*2	PWM mode 2 output	—

x: Don't care

Notes: 1. TIOCA4 input when MD3 to MD0 = B'0000 or B'01xx and IOA3 to IOA0 = B'10xx.

2. TIOCB4 output is disabled.

Pin Selection Method and Pin Functions
**P23/TIOCD3/
TMC10**

This pin is used as the 8-bit timer external clock input pin when external clock is selected with bits CKS2 to CKS0 in TCR0.

The pin function is switched as shown below according to the combination of the TPU channel 3 setting by bits MD3 to MD0 in TMDR3, bits IOD3 to IOD0 in TIOR3L, bits CCLR2 to CCLR0 in TCR3, and bit P23DDR.

TPU Channel 3 Setting	Table Below (1)	Table Below (2)	
P23DDR	—	0	1
Pin function	TIOCD3 output	P23 input	P23 output
		TIOCD3 input *	
TMC10 input			

TPU Channel 3 Setting	(2)	(1)	(2)	(2)	(1)	(2)
MD3 to MD0	B'0000		B'0010	B'0011		
IOD3 to IOD0	B'0000 B'0100 B'1xxx	B'0001 to B'0011 B'0101 to B'0111	—	B'xx00	Other than B'xx00	
CCLR2 to CCLR0	—	—	—	—	Other than B'110	B'110
Output function	—	Output compare output	—	—	PWM mode 2 output	—

×: Don't care

Note: * TIOCD3 input when MD3 to MD0 = B'0000 and IOD3 to IOD0 = B'10xx.

Pin Selection Method and Pin Functions

P22/TIOCC3/
TMR10

This pin is used as the 8-bit timer counter reset pin when bits CCLR1 and CCLR0 in TCR0 are both set to 1.
The pin function is switched as shown below according to the combination of the TPU channel 3 setting by bits MD3 to MD0 in TMDR3, bits IOC3 to IOC0 in TIOR3L, bits CCLR2 to CCLR0 in TCR3, and bit P22DDR.

TPU Channel 3 Setting	Table Below (1)	Table Below (2)	
P22DDR	—	0	1
Pin function	TIOCC3 output	P22 input	P22 output
		TIOCC3 input *1	
TMR10 input			

TPU Channel 3 Setting	(2)	(1)	(2)	(1)	(1)	(2)
MD3 to MD0	B'0000		B'001×	B'0010	B'0011	
IOC3 to IOC0	B'0000 B'0100 B'1×××	B'0001 to B'0011 B'0101 to B'0111	B'××00	Other than B'××00		
CCLR2 to CCLR0	—	—	—	—	Other than B'101	B'101
Output function	—	Output compare output	—	PWM mode 1 output *2	PWM mode 2 output	—

×: Don't care

- Notes: 1. TIOCC3 input when MD3 to MD0 = B'0000 and IOC3 to IOC0 = B'10××.
2. TIOCD3 output is disabled.
When BFA = 1 or BFB = 1 in TMDR3, output is disabled and setting (2) applies.

Pin Selection Method and Pin Functions

P21/TIOCB3 The pin function is switched as shown below according to the combination of the TPU channel 3 setting by bits MD3 to MD0 in TMDR3, bits IOB3 to IOB0 in TIOR3H, bits CCLR2 to CCLR0 in TCR3, and bit P21DDR.

TPU Channel 3 Setting	Table Below (1)	Table Below (2)	
P21DDR	—	0	1
Pin function	TIOCB3 output	P21 input	P21 output
		TIOCB3 input *	

TPU Channel 3 Setting	(2)	(1)	(2)	(2)	(1)	(2)
MD3 to MD0	B'0000		B'0010	B'0011		
IOB3 to IOB0	B'0000 B'0100 B'1xxx	B'0001 to B'0011 B'0101 to B'0111	—	B'xx00	Other than B'xx00	
CCLR2 to CCLR0	—	—	—	—	Other than B'010	B'010
Output function	—	Output compare output	—	—	PWM mode 2 output	—

×: Don't care

Note: * TIOCB3 input when MD3 to MD0 = B'0000 and IOB3 to IOB0 = B'10xx.

Pin Selection Method and Pin Functions

P20/TIOCA3

The pin function is switched as shown below according to the combination of the TPU channel 3 setting by bits MD3 to MD0 in TMDR3, bits IOA3 to IOA0 in TIOR3H, bits CCLR2 to CCLR0 in TCR3, and bit P20DDR.

TPU Channel 3 Setting	Table Below (1)	Table Below (2)	
P20DDR	—	0	1
Pin function	TIOCA3 output	P20 input	P20 output
		TIOCA3 input ^{*1}	

TPU Channel 3 Setting	(2)	(1)	(2)	(1)	(1)	(2)
MD3 to MD0	B'0000		B'001×	B'0010	B'0011	
IOA3 to IOA0	B'0000 B'0100 B'1×××	B'0001 to B'0011 B'0101 to B'0111	B'××00	Other than B'××00		
CCLR2 to CCLR0	—	—	—	—	Other than B'001	B'001
Output function	—	Output compare output	—	PWM mode 1 output ^{*2}	PWM mode 2 output	—

×: Don't care

- Notes: 1. TIOCA3 input when MD3 to MD0 = B'0000 and IOA3 to IOA0 = B'10××.
2. TIOCB3 output is disabled.
-

8.4 Port 3

8.4.1 Overview

Port 3 is a 6-bit I/O port. Port 3 pins also function as SCI I/O pins (TxD0, RxD0, SCK0, TxD1, RxD1, and SCK1) and interrupt input pins ($\overline{\text{IRQ4}}$, $\overline{\text{IRQ5}}$). Port 3 pin functions are the same in all operating modes. The interrupt input pins ($\overline{\text{IRQ4}}$, $\overline{\text{IRQ5}}$) are Schmitt-triggered inputs.

Figure 8.3 shows the port 3 pin configuration.

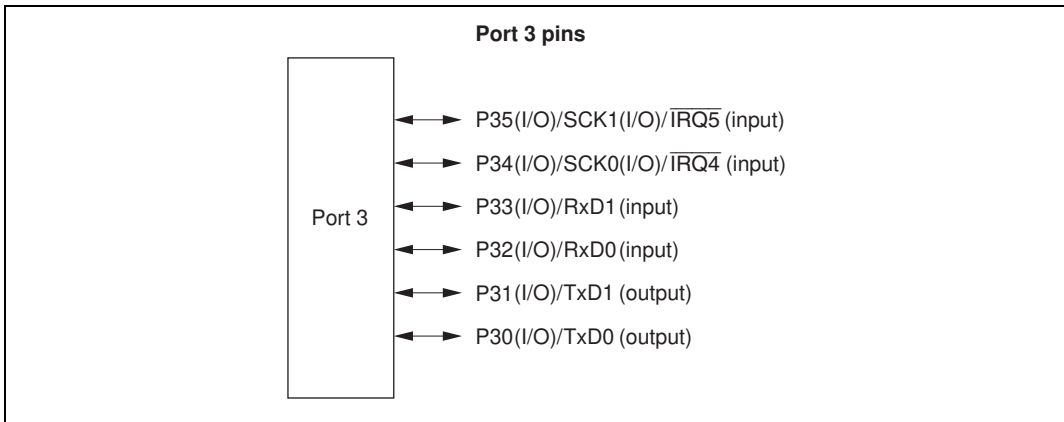

Figure 8.3 Port 3 Pin Functions

8.4.2 Register Configuration

Table 8.6 shows the port 3 register configuration.

Table 8.6 Port 3 Registers

Name	Abbreviation	R/W	Initial Value ^{*1}	Address ^{*2}
Port 3 data direction register	P3DDR	W	H'00	H'FEB2
Port 3 data register	P3DR	R/W	H'00	H'FF62
Port 3 register	PORT3	R	Undefined	H'FF52
Port 3 open drain control register	P3ODR	R/W	H'00	H'FF76

Notes: 1. Value of bits 5 to 0.

2. Lower 16 bits of the address.

Port 3 Data Direction Register (P3DDR)

Bit	:	7	6	5	4	3	2	1	0
		—	—	P35DDR	P34DDR	P33DDR	P32DDR	P31DDR	P30DDR
Initial value	:	Undefined	Undefined	0	0	0	0	0	0
R/W	:	—	—	W	W	W	W	W	W

P3DDR is an 8-bit write-only register, the individual bits of which specify input or output for the pins of port 3. Bits 7 and 6 are reserved. P3DDR cannot be read; if it is, an undefined value will be read.

Setting P3DDR bits to 1 makes the corresponding port 3 pins output pins, while clearing the bits to 0 makes the pins input pins.

P3DDR is initialized to H'00 (bits 5 to 0) by a reset, and in hardware standby mode. It retains its prior state in software standby mode. As the SCI is initialized, the pin states are determined by the P3DDR and P3DR specifications.

Port 3 Data Register (P3DR)

Bit	:	7	6	5	4	3	2	1	0
		—	—	P35DR	P34DR	P33DR	P32DR	P31DR	P30DR
Initial value	:	Undefined	Undefined	0	0	0	0	0	0
R/W	:	—	—	R/W	R/W	R/W	R/W	R/W	R/W

P3DR is an 8-bit readable/writable register that stores output data for the port 3 pins (P35 to P30).

Bits 7 and 6 are reserved; they return an undetermined value if read, and cannot be modified.

P3DR is initialized to H'00 (bits 5 to 0) by a on reset, and in hardware standby mode. It retains its prior state in software standby mode.

Port 3 Register (PORT3)

Bit	:	7	6	5	4	3	2	1	0
		—	—	P35	P34	P33	P32	P31	P30
Initial value	:	Undefined	Undefined	—*	—*	—*	—*	—*	—*
R/W	:	—	—	R	R	R	R	R	R

Note: * Determined by state of pins P35 to P30.

PORT3 is an 8-bit read-only register that shows the pin states, and cannot be modified. Writing of output data for the port 3 pins (P35 to P30) must always be performed on P3DR.

Bits 7 and 6 are reserved; they return an undetermined value if read, and cannot be modified.

If a port 3 read is performed while P3DDR bits are set to 1, the P3DR values are read. If a port 3 read is performed while P3DDR bits are cleared to 0, the pin states are read.

After a reset and in hardware standby mode, PORT3 contents are determined by the pin states, as P3DDR and P3DR are initialized. PORT3 retains its prior state in software standby mode.

Port 3 Open Drain Control Register (P3ODR)

Bit	:	7	6	5	4	3	2	1	0
		—	—	P35ODR	P34ODR	P33ODR	P32ODR	P31ODR	P30ODR
Initial value	:	Undefined	Undefined	0	0	0	0	0	0
R/W	:	—	—	R/W	R/W	R/W	R/W	R/W	R/W

P3ODR is an 8-bit readable/writable register that controls the PMOS on/off status for each port 3 pin (P35 to P30).

Bits 7 and 6 are reserved; they return an undetermined value if read, and cannot be modified.

Setting P3ODR bits to 1 makes the corresponding port 3 pins NMOS open-drain output pins, while clearing the bits to 0 makes the pins CMOS output pins.

P3ODR is initialized to H'00 (bits 5 to 0) by a reset, and in hardware standby mode. It retains its prior state in software standby mode.

8.4.3 Pin Functions

Port 3 pins also function as SCI I/O pins (TxD0, RxD0, SCK0, TxD1, RxD1, and SCK1) and interrupt input pins ($\overline{\text{IRQ4}}$, $\overline{\text{IRQ5}}$). Port 3 pin functions are shown in table 8.7.

Table 8.7 Port 3 Pin Functions

Pin	Selection Method and Pin Functions				
P35/SCK1/ $\overline{\text{IRQ5}}$	The pin function is switched as shown below according to the combination of bit C/ $\overline{\text{A}}$ in the SCI1 SMR, bits CKE0 and CKE1 in SCR, and bit P35DDR.				
CKE1	0				1
C/ $\overline{\text{A}}$	0			1	—
CKE0	0		1	—	—
P35DDR	0	1	—	—	—
Pin function	P35 input pin	P35 output pin ^{*1}	SCK1 output pin ^{*1}	SCK1 output pin ^{*1}	SCK1 input pin
	$\overline{\text{IRQ5}}$ interrupt input pin ^{*2}				

- Notes: 1. When P35ODR = 1, the pin becomes an NMOS open-drain output.
 2. When this pin is used as an external interrupt input, it should not be used as an input/output pin with other functions.

P34/SCK0/ $\overline{\text{IRQ4}}$	The pin function is switched as shown below according to the combination of bit C/ $\overline{\text{A}}$ in the SCI0 SMR, bits CKE0 and CKE1 in SCR, and bit P34DDR.				
CKE1	0				1
C/ $\overline{\text{A}}$	0			1	—
CKE0	0		1	—	—
P34DDR	0	1	—	—	—
Pin function	P34 input pin	P34 output pin ^{*1}	SCK0 output pin ^{*1}	SCK0 output pin ^{*1}	SCK0 input pin
	$\overline{\text{IRQ4}}$ interrupt input pin ^{*2}				

- Notes: 1. When P34ODR = 1, the pin becomes an NMOS open-drain output.
 2. When this pin is used as an external interrupt input, it should not be used as an input/output pin with other functions.

Pin Selection Method and Pin Functions

P33/RxD1 The pin function is switched as shown below according to the combination of bit RE in the SCI1 SCR, and bit P33DDR.

RE	0		1
P33DDR	0	1	—
Pin function	P33 input pin	P33 output pin*	RxD1 input pin

Note: * When P33ODR = 1, the pin becomes an NMOS open-drain output.

P32/RxD0 The pin function is switched as shown below according to the combination of bit RE in the SCI0 SCR, and bit P32DDR.

RE	0		1
P32DDR	0	1	—
Pin function	P32 input pin	P32 output pin*	RxD0 input pin

Note: * When P32ODR = 1, the pin becomes an NMOS open-drain output.

P31/TxD1 The pin function is switched as shown below according to the combination of bit TE in the SCI1 SCR, and bit P31DDR.

TE	0		1
P31DDR	0	1	—
Pin function	P31 input pin	P31 output pin*	TxD1 output pin

Note: * When P31ODR = 1, the pin becomes an NMOS open-drain output.

P30/TxD0 The pin function is switched as shown below according to the combination of bit TE in the SCI0 SCR, and bit P30DDR.

TE	0		1
P30DDR	0	1	—
Pin function	P30 input pin	P30 output pin*	TxD0 output pin

Note: * When P30ODR = 1, the pin becomes an NMOS open-drain output.

8.5 Port 4

8.5.1 Overview

Port 4 is an 8-bit input-only port. Port 4 pins also function as A/D converter analog input pins (AN0 to AN7) and D/A converter analog output pins (DA0 and DA1). Port 4 pin functions are the same in all operating modes. Figure 8.4 shows the port 4 pin configuration.

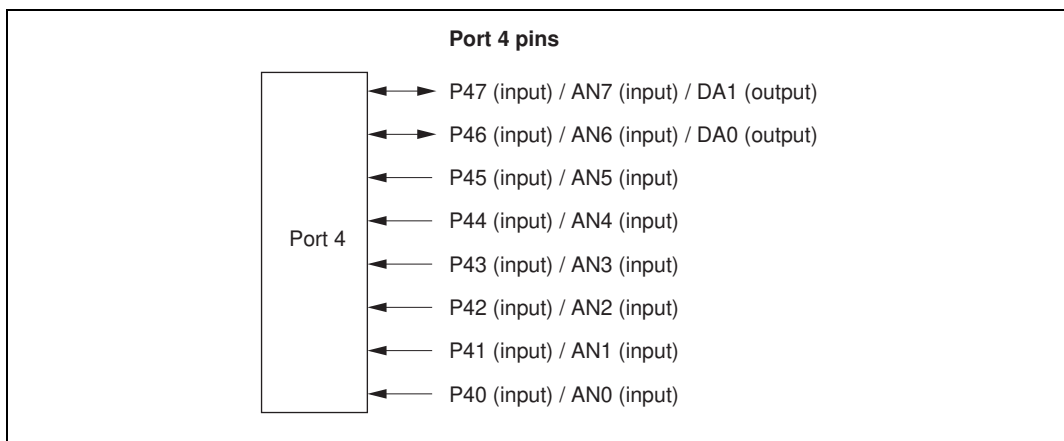

Figure 8.4 Port 4 Pin Functions

8.5.2 Register Configuration

Table 8.8 shows the port 4 register configuration. Port 4 is an input-only port, and does not have a data direction register or data register.

Table 8.8 Port 4 Register

Name	Abbreviation	R/W	Initial Value	Address*
Port 4 register	PORT4	R	Undefined	H'FF53

Note: * Lower 16 bits of the address.

Port 4 Register (PORT4): The pin states are always read when a port 4 read is performed.

Bit	:	7	6	5	4	3	2	1	0
		P47	P46	P45	P44	P43	P42	P41	P40
Initial value :		—*	—*	—*	—*	—*	—*	—*	—*
R/W	:	R	R	R	R	R	R	R	R

Note: * Determined by state of pins P47 to P40.

8.5.3 Pin Functions

Port 4 pins also function as A/D converter analog input pins (AN0 to AN7) and D/A converter analog output pins (DA0 and DA1).

8.6 Port A

8.6.1 Overview

Port A is a 4-bit I/O port. Port A pins also function as address bus outputs. The pin functions change according to the operating mode.

Port A has a built-in MOS input pull-up function that can be controlled by software.

Figure 8.5 shows the port A pin configuration.

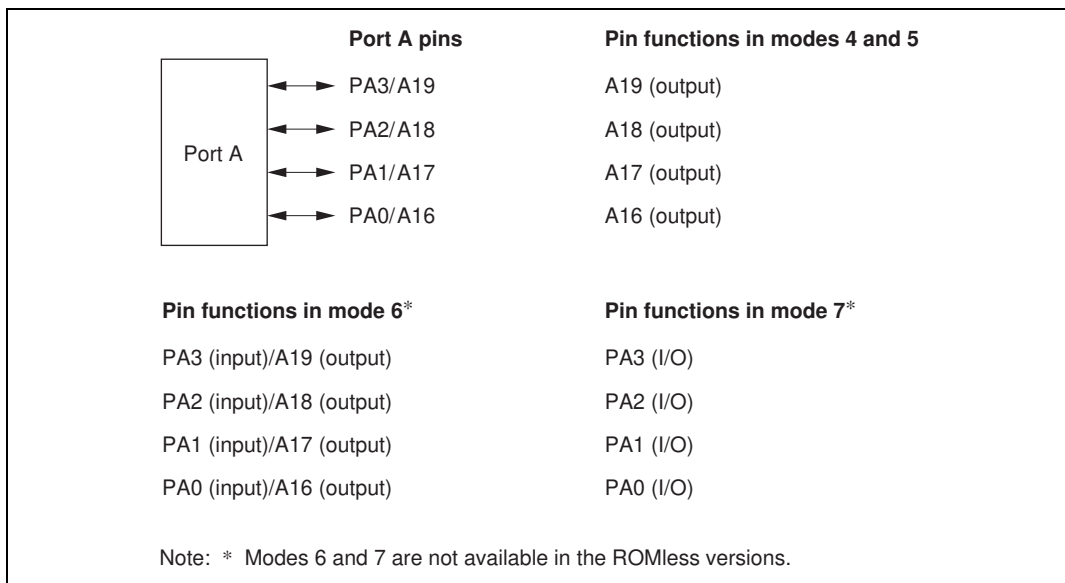

Figure 8.5 Port A Pin Functions

8.6.2 Register Configuration

Table 8.9 shows the port A register configuration.

Table 8.9 Port A Registers

Name	Abbreviation	R/W	Initial Value ^{*1}	Address ^{*2}
Port A data direction register	PADDR	W	H'0	H'FEB9
Port A data register	PADR	R/W	H'0	H'FF69
Port A register	PORTA	R	Undefined	H'FF59
Port A MOS pull-up control register	PAPCR	R/W	H'0	H'FF70
Port A open-drain control register	PAODR	R/W	H'0	H'FF77

Notes: 1. Value of bits 3 to 0.

2. Lower 16 bits of the address.

Port A Data Direction Register (PADDR)

Bit	:	7	6	5	4	3	2	1	0
		—	—	—	—	PA3DDR	PA2DDR	PA1DDR	PA0DDR
Initial value	:	Undefined	Undefined	Undefined	Undefined	0	0	0	0
R/W	:	—	—	—	—	W	W	W	W

PADDR is an 8-bit write-only register, the individual bits of which specify input or output for the pins of port A. PADDR cannot be read; if it is, an undefined value will be read. Bits 7 to 4 are reserved.

PADDR is initialized to H'0 (bits 3 to 0) by a reset and in hardware standby mode. It retains its prior state in software standby mode. The OPE bit in SBYCR is used to select whether the address output pins retain their output state or become high-impedance when a transition is made to software standby mode.

- Modes 4 and 5

The corresponding port A pins are address outputs irrespective of the value of bits PA3DDR to PA0DDR.

- Mode 6*

Setting PADDR bits to 1 makes the corresponding port A pins address outputs, while clearing the bits to 0 makes the pins input ports.

- Mode 7*

Setting PADDR bits to 1 makes the corresponding port A pins output ports, while clearing the bits to 0 makes the pins input ports.

Note: * Modes 6 and 7 are not available in the ROMless versions.

Port A Data Register (PADR)

Bit	:	7	6	5	4	3	2	1	0
		—	—	—	—	PA3DR	PA2DR	PA1DR	PA0DR
Initial value	:	Undefined	Undefined	Undefined	Undefined	0	0	0	0
R/W	:	—	—	—	—	R/W	R/W	R/W	R/W

PADR is an 8-bit readable/writable register that stores output data for the port A pins (PA3 to PA0).

Bits 7 to 4 are reserved; they return an undetermined value if read, and cannot be modified.

PADR is initialized to H'0 (bits 3 to 0) by a reset, and in hardware standby mode. It retains its prior state in software standby mode.

Port A Register (PORTA)

Bit	:	7	6	5	4	3	2	1	0
		—	—	—	—	PA3	PA2	PA1	PA0
Initial value	:	Undefined	Undefined	Undefined	Undefined	—*	—*	—*	—*
R/W	:	—	—	—	—	R	R	R	R

Note: * Determined by state of pins PA3 to PA0.

PORTA is an 8-bit read-only register that shows the pin states. It cannot be written to. Writing of output data for the port A pins (PA3 to PA0) must always be performed on PADR.

Bits 7 to 4 are reserved; they return an undetermined value if read, and cannot be modified.

If a port A read is performed while PADDR bits are set to 1, the PADR values are read. If a port A read is performed while PADDR bits are cleared to 0, the pin states are read.

After a reset and in hardware standby mode, PORTA contents are determined by the pin states, as PADDR and PADR are initialized. PORTA retains its prior state in software standby mode.

Port A MOS Pull-Up Control Register (PAPCR)

Bit	:	7	6	5	4	3	2	1	0
		—	—	—	—	PA3PCR	PA2PCR	PA1PCR	PA0PCR
Initial value	:	Undefined	Undefined	Undefined	Undefined	0	0	0	0
R/W	:	—	—	—	—	R/W	R/W	R/W	R/W

PAPCR is an 8-bit readable/writable register that controls the MOS input pull-up function incorporated into port A on an individual bit basis.

Bits 7 to 4 are reserved; they return an undetermined value if read, and cannot be modified.

Bits 3 to 0 are valid in modes 6 and 7*, and all the bits are invalid in modes 4 and 5. When PADDR bits are cleared to 0 (input port setting), setting the corresponding PAPCR bits to 1 turns on the MOS input pull-up for the corresponding pins.

PAPCR is initialized to H'0 (bits 3 to 0) by a reset, and in hardware standby mode. It retains its prior state in software standby mode.

Note: * Modes 6 and 7 are not available in the ROMless versions.

Port A Open Drain Control Register (PAODR)

Bit	:	7	6	5	4	3	2	1	0
		—	—	—	—	PA3ODR	PA2ODR	PA1ODR	PA0ODR
Initial value	:	Undefined	Undefined	Undefined	Undefined	0	0	0	0
R/W	:	—	—	—	—	R/W	R/W	R/W	R/W

PAODR is an 8-bit readable/writable register that controls whether PMOS is on or off for each port A pin (PA3 to PA0).

Bits 7 to 4 are reserved; they return an undetermined value if read, and cannot be modified.

All bits are valid in mode 7.*

Setting PAODR bits to 1 makes the corresponding port A pins NMOS open-drain outputs, while clearing the bits to 0 makes the pins CMOS outputs.

PAODR is initialized to H'0 (bits 3 to 0) by a reset, and in hardware standby mode. It retains its prior state in software standby mode.

Note: * Modes 6 and 7 are not available in the ROMless versions.

8.6.3 Pin Functions

Modes 4 and 5: In modes 4 and 5, the lower 4 bits of port A are designated as address outputs automatically.

Port A pin functions in modes 4 and 5 are shown in figure 8.6.

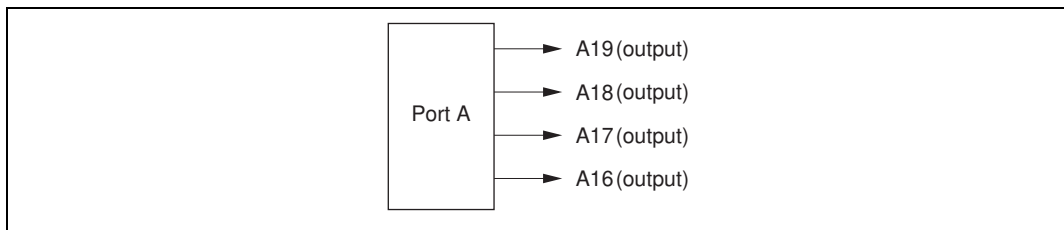

Figure 8.6 Port A Pin Functions (Modes 4 and 5)

Mode 6*: In mode 6*, port A pins function as address outputs or input ports. Input or output can be specified on an individual bit basis. Setting PADDR bits to 1 makes the corresponding port A pins address outputs, while clearing the bits to 0 makes the pins input ports.

Port A pin functions in mode 6 are shown in figure 8.7.

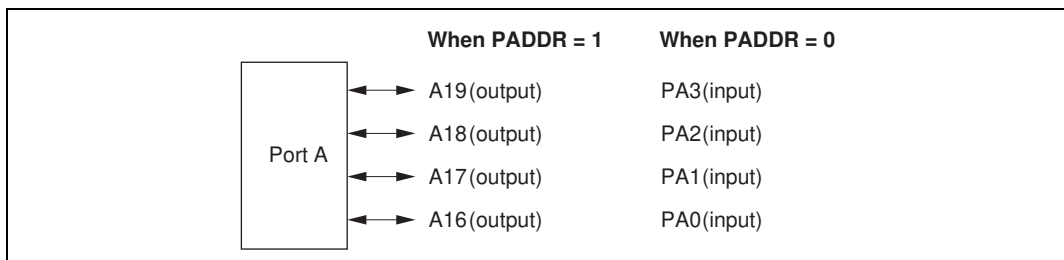

Figure 8.7 Port A Pin Functions (Mode 6)

Mode 7*: In mode 7*, port A pins function as I/O ports. Input or output can be specified for each pin on an individual bit basis. Setting PADDR bits to 1 makes the corresponding port A pins output ports, while clearing the bits to 0 makes the pins input ports.

Port A pin functions in mode 7 are shown in figure 8.8.

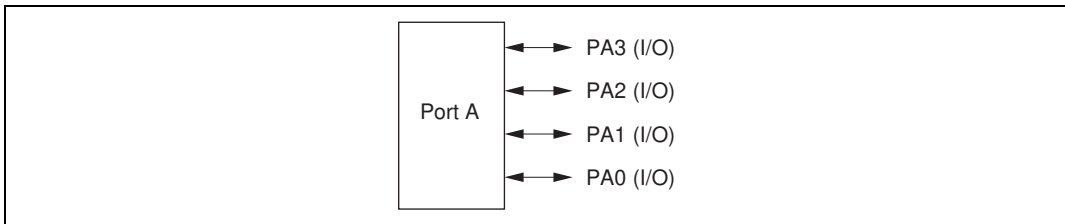

Figure 8.8 Port A Pin Functions (Mode 7)

Note: * Modes 6 and 7 are not available in the ROMless versions.

8.6.4 MOS Input Pull-Up Function

Port A has a built-in MOS input pull-up function that can be controlled by software. This MOS input pull-up function can be used in modes 6 and 7*, and cannot be used in modes 4 and 5. MOS input pull-up can be specified as on or off on an individual bit basis.

When PADDR bits are cleared to 0, setting the corresponding PAPCR bits to 1 turns on the MOS input pull-up for that pins.

The MOS input pull-up function is in the off state after a reset, and in hardware standby mode. The prior state is retained in software standby mode.

Table 8.10 summarizes the MOS input pull-up states.

Table 8.10 MOS Input Pull-Up States (Port A)

Modes	Reset	Hardware Standby Mode	Software Standby Mode	In Other Operations
6, 7*	PA3 to PA0 OFF	OFF	ON/OFF	ON/OFF
4, 5	PA3 to PA0		OFF	OFF

Legend:

OFF: MOS input pull-up is always off.

ON/OFF: On when PADDR = 0 and PAPCR = 1; otherwise off.

Note: * Modes 6 and 7 are not available in the ROMless versions.

8.7 Port B

8.7.1 Overview

Port B is an 8-bit I/O port. Port B has an address bus output function, and the pin functions change according to the operating mode.

Port B has a built-in MOS input pull-up function that can be controlled by software.

Figure 8.9 shows the port B pin configuration.

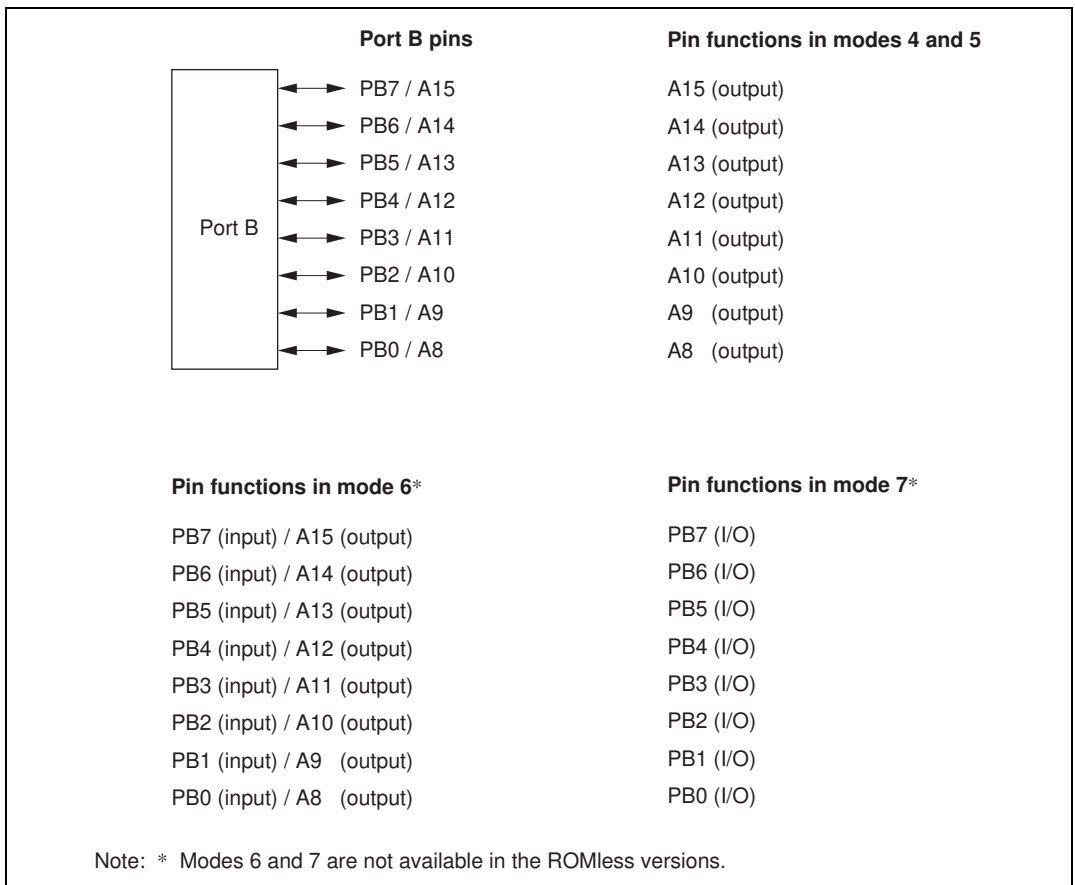

Figure 8.9 Port B Pin Functions

8.7.2 Register Configuration

Table 8.11 shows the port B register configuration.

Table 8.11 Port B Registers

Name	Abbreviation	R/W	Initial Value	Address*
Port B data direction register	PBDDR	W	H'00	H'FEBA
Port B data register	PBDR	R/W	H'00	H'FF6A
Port B register	PORTB	R	Undefined	H'FF5A
Port B MOS pull-up control register	PBPCR	R/W	H'00	H'FF71

Note: * Lower 16 bits of the address.

Port B Data Direction Register (PBDDR)

Bit	:	7	6	5	4	3	2	1	0
		PB7DDR	PB6DDR	PB5DDR	PB4DDR	PB3DDR	PB2DDR	PB1DDR	PB0DDR
Initial value :		0	0	0	0	0	0	0	0
R/W	:	W	W	W	W	W	W	W	W

PBDDR is an 8-bit write-only register, the individual bits of which specify input or output for the pins of port B. PBDDR cannot be read; if it is, an undefined value will be read.

PBDDR is initialized to H'00 by a reset, and in hardware standby mode. It retains its prior state in software standby mode. The OPE bit in SBYCR is used to select whether the address output pins retain their output state or become high-impedance when a transition is made to software standby mode.

- Modes 4 and 5
The corresponding port B pins are address outputs irrespective of the value of the PBDDR bits.
- Mode 6*
Setting PBDDR bits to 1 makes the corresponding port B pins address outputs, while clearing the bits to 0 makes the pins input ports.
- Mode 7*
Setting PBDDR bits to 1 makes the corresponding port B pins outputs, while clearing the bits to 0 makes the pins input ports.

Note: * Modes 6 and 7 are not available in the ROMless versions.

Port B Data Register (PBDR)

Bit	:	7	6	5	4	3	2	1	0								
		<table border="1"> <tr> <td>PB7DR</td> <td>PB6DR</td> <td>PB5DR</td> <td>PB4DR</td> <td>PB3DR</td> <td>PB2DR</td> <td>PB1DR</td> <td>PB0DR</td> </tr> </table>								PB7DR	PB6DR	PB5DR	PB4DR	PB3DR	PB2DR	PB1DR	PB0DR
PB7DR	PB6DR	PB5DR	PB4DR	PB3DR	PB2DR	PB1DR	PB0DR										
Initial value	:	0	0	0	0	0	0	0	0								
R/W	:	R/W	R/W	R/W	R/W	R/W	R/W	R/W	R/W								

PBDR is an 8-bit readable/writable register that stores output data for the port B pins (PB7 to PB0). PBDR is initialized to H'00 by a reset, and in hardware standby mode. It retains its prior state in software standby mode.

Port B Register (PORTB)

Bit	:	7	6	5	4	3	2	1	0								
		<table border="1"> <tr> <td>PB7</td> <td>PB6</td> <td>PB5</td> <td>PB4</td> <td>PB3</td> <td>PB2</td> <td>PB1</td> <td>PB0</td> </tr> </table>								PB7	PB6	PB5	PB4	PB3	PB2	PB1	PB0
PB7	PB6	PB5	PB4	PB3	PB2	PB1	PB0										
Initial value	:	—*	—*	—*	—*	—*	—*	—*	—*								
R/W	:	R	R	R	R	R	R	R	R								

Note: * Determined by state of pins PB7 to PB0.

PORTB is an 8-bit read-only register that shows the pin states. It cannot be written to. Writing of output data for the port B pins (PB7 to PB0) must always be performed on PBDR.

If a port B read is performed while PBDDR bits are set to 1, the PBDR values are read. If a port B read is performed while PBDDR bits are cleared to 0, the pin states are read.

After a reset and in hardware standby mode, PORTB contents are determined by the pin states, as PBDDR and PBDR are initialized. PORTB retains its prior state in software standby mode.

Port B MOS Pull-Up Control Register (PBPCR)

Bit	:	7	6	5	4	3	2	1	0
		PB7PCR	PB6PCR	PB5PCR	PB4PCR	PB3PCR	PB2PCR	PB1PCR	PB0PCR
Initial value	:	0	0	0	0	0	0	0	0
R/W	:	R/W	R/W	R/W	R/W	R/W	R/W	R/W	R/W

PBPCR is an 8-bit readable/writable register that controls the MOS input pull-up function incorporated into port B on an individual bit basis.

When PBDDR bits are cleared to 0 (input port setting) in mode 6 or 7, setting the corresponding PBPCR bits to 1 turns on the MOS input pull-up for the corresponding pins.

PBPCR is initialized to H'00 by a reset, and in hardware standby mode. It retains its prior state in software standby mode.

8.7.3 Pin Functions

Modes 4 and 5: In modes 4 and 5, port B pins are automatically designated as address outputs.

Port B pin functions in modes 4 and 5 are shown in figure 8.10.

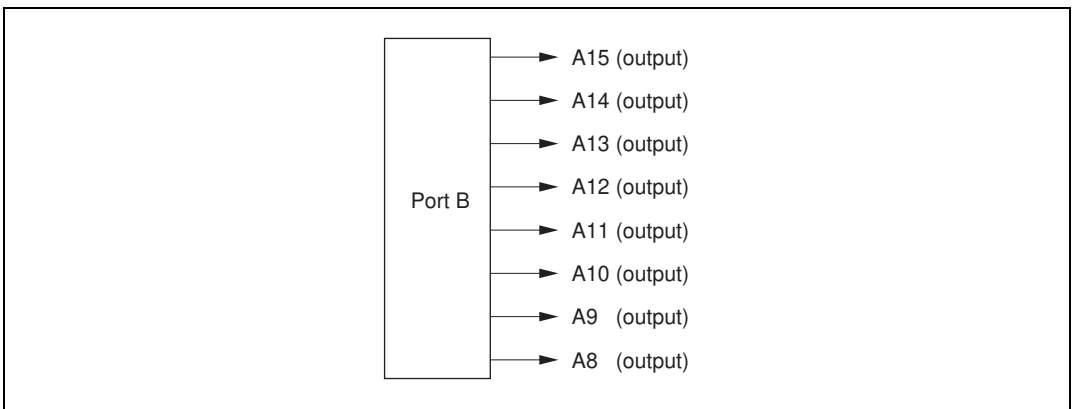

Figure 8.10 Port B Pin Functions (Modes 4 and 5)

Mode 6*: In mode 6, port B pins function as address outputs or input ports. Input or output can be specified on an individual bit basis. Setting PBDDR bits to 1 makes the corresponding port B pins address outputs, while clearing the bits to 0 makes the pins input ports.

Port B pin functions in mode 6 are shown in figure 8.11

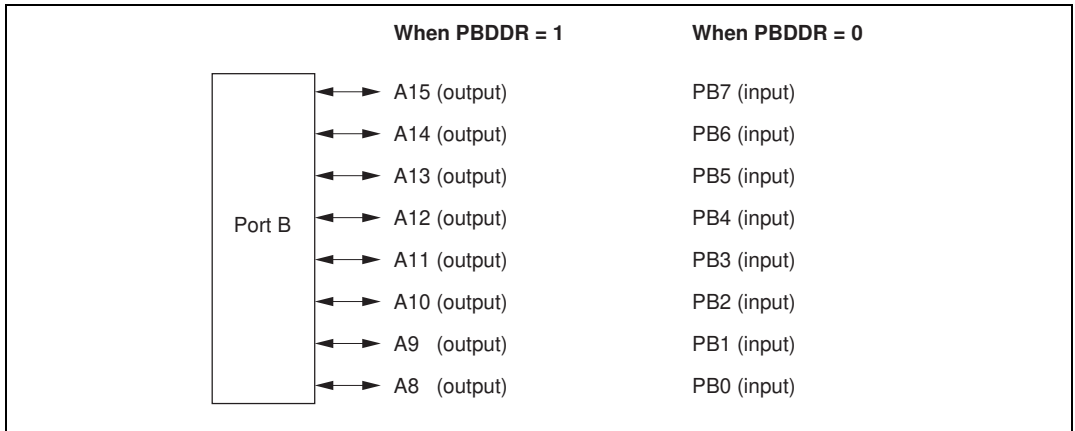

Figure 8.11 Port B Pin Functions (Mode 6)

Mode 7*: In mode 7, port B pins function as I/O ports. Input or output can be specified for each pin on an individual bit basis. Setting PBDDR bits to 1 makes the corresponding port B pins output ports, while clearing the bits to 0 makes the pins input ports.

Port B pin functions in mode 7 are shown in figure 8.12.

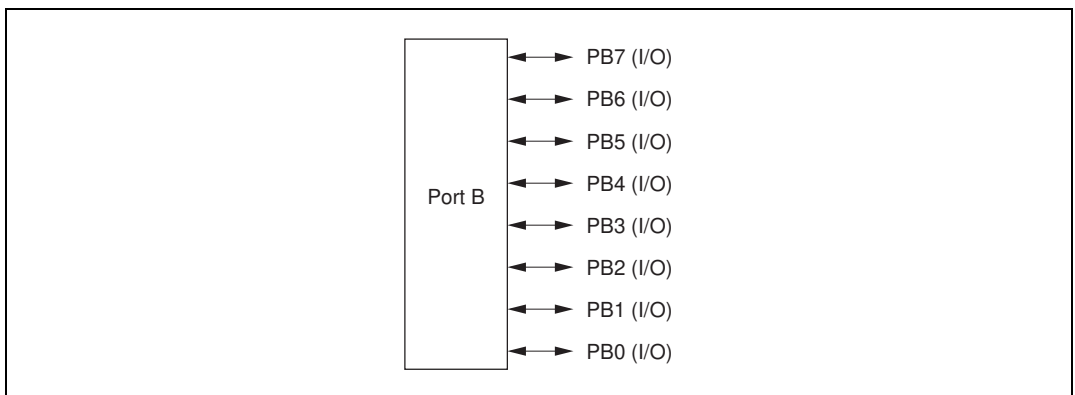

Figure 8.12 Port B Pin Functions (Mode 7)

Note: * Modes 6 and 7 are not available in the ROMless versions.

8.7.4 MOS Input Pull-Up Function

Port B has a built-in MOS input pull-up function that can be controlled by software. This MOS input pull-up function can be used in modes 6 and 7, and can be specified as on or off on an individual bit basis.

When PBDDR bits are cleared to 0 in mode 6 or 7, setting the corresponding PBPCR bits to 1 turns on the MOS input pull-up for that pins.

The MOS input pull-up function is in the off state after a reset, and in hardware standby mode. The prior state is retained in software standby mode.

Table 8.12 summarizes the MOS input pull-up states.

Table 8.12 MOS Input Pull-Up States (Port B)

Modes	Reset	Hardware Standby Mode	Software Standby Mode	In Other Operations
4, 5	OFF	OFF	OFF	OFF
6, 7			ON/OFF	ON/OFF

Legend:

OFF: MOS input pull-up is always off.

ON/OFF: On when PBDDR = 0 and PBPCR = 1; otherwise off.

8.8 Port C

8.8.1 Overview

Port C is an 8-bit I/O port. Port C has an address bus output function, and the pin functions change according to the operating mode.

Port C has a built-in MOS input pull-up function that can be controlled by software.

Figure 8.13 shows the port C pin configuration.

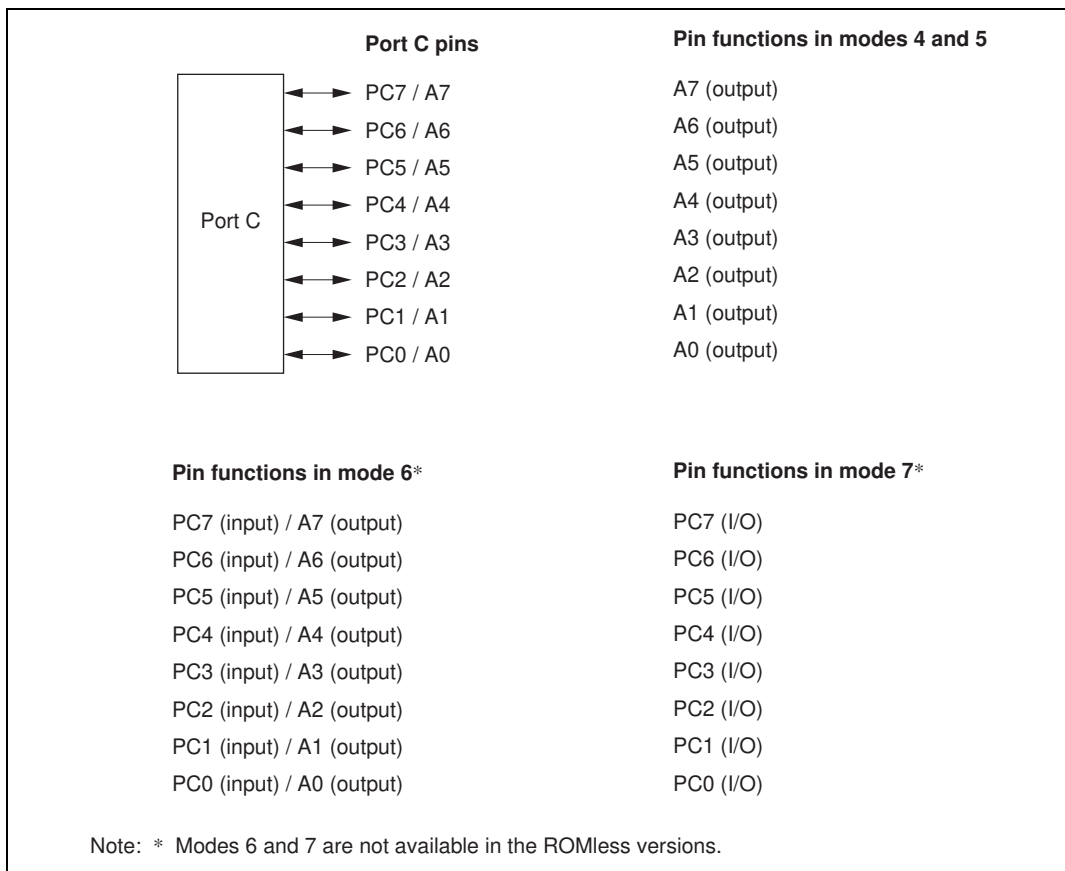

Figure 8.13 Port C Pin Functions

8.8.2 Register Configuration

Table 8.13 shows the port C register configuration.

Table 8.13 Port C Registers

Name	Abbreviation	R/W	Initial Value	Address*
Port C data direction register	PCDDR	W	H'00	H'FE8B
Port C data register	PCDR	R/W	H'00	H'FF6B
Port C register	PORTC	R	Undefined	H'FF5B
Port C MOS pull-up control register	PCPCR	R/W	H'00	H'FF72

Note: * Lower 16 bits of the address.

Port C Data Direction Register (PCDDR)

Bit	:	7	6	5	4	3	2	1	0
		PC7DDR	PC6DDR	PC5DDR	PC4DDR	PC3DDR	PC2DDR	PC1DDR	PC0DDR
Initial value :		0	0	0	0	0	0	0	0
R/W	:	W	W	W	W	W	W	W	W

PCDDR is an 8-bit write-only register, the individual bits of which specify input or output for the pins of port C. PCDDR cannot be read; if it is, an undefined value will be read.

PCDDR is initialized to H'00 by a reset, and in hardware standby mode. It retains its prior state in software standby mode. The OPE bit in SBYCR is used to select whether the address output pins retain their output state or become high-impedance when a transition is made to software standby mode.

- Modes 4 and 5
The corresponding port C pins are address outputs irrespective of the value of the PCDDR bits.
- Mode 6*
Setting PCDDR bits to 1 makes the corresponding port C pin address outputs, while clearing the bits to 0 makes the pins input ports.
- Mode 7*
Setting PCDDR bits to 1 makes the corresponding port C pins an output ports, while clearing the bits to 0 makes the pins input ports.

Note: * Modes 6 and 7 are not available in the ROMless versions.

Port C Data Register (PCDR)

Bit	:	7	6	5	4	3	2	1	0
		PC7DR	PC6DR	PC5DR	PC4DR	PC3DR	PC2DR	PC1DR	PC0DR
Initial value	:	0	0	0	0	0	0	0	0
R/W	:	R/W	R/W	R/W	R/W	R/W	R/W	R/W	R/W

PCDR is an 8-bit readable/writable register that stores output data for the port C pins (PC7 to PC0).

PCDR is initialized to H'00 by a reset, and in hardware standby mode. It retains its prior state in software standby mode.

Port C Register (PORTC)

Bit	:	7	6	5	4	3	2	1	0
		PC7	PC6	PC5	PC4	PC3	PC2	PC1	PC0
Initial value	:	—*	—*	—*	—*	—*	—*	—*	—*
R/W	:	R	R	R	R	R	R	R	R

Note: * Determined by state of pins PC7 to PC0.

PORTC is an 8-bit read-only register that shows the pin states. It cannot be written to. Writing of output data for the port C pins (PC7 to PC0) must always be performed on PCDR.

If a port C read is performed while PCDDR bits are set to 1, the PCDR values are read. If a port C read is performed while PCDDR bits are cleared to 0, the pin states are read.

After a reset and in hardware standby mode, PORTC contents are determined by the pin states, as PCDDR and PCDR are initialized. PORTC retains its prior state in software standby mode.

Port C MOS Pull-Up Control Register (PCPCR)

Bit	:	7	6	5	4	3	2	1	0
		PC7PCR	PC6PCR	PC5PCR	PC4PCR	PC3PCR	PC2PCR	PC1PCR	PC0PCR
Initial value	:	0	0	0	0	0	0	0	0
R/W	:	R/W	R/W	R/W	R/W	R/W	R/W	R/W	R/W

PCPCR is an 8-bit readable/writable register that controls the MOS input pull-up function incorporated into port C on an individual bit basis.

When PCDDR bits are cleared to 0 (input port setting) in mode 6 or 7, setting the corresponding PCPCR bits to 1 turns on the MOS input pull-up for the corresponding pins.

PCPCR is initialized to H'00 by a reset, and in hardware standby mode. It retains its prior state in software standby mode.

8.8.3 Pin Functions

Modes 4 and 5: In modes 4 and 5, port C pins are automatically designated as address outputs.

Port C pin functions in modes 4 and 5 are shown in figure 8.14.

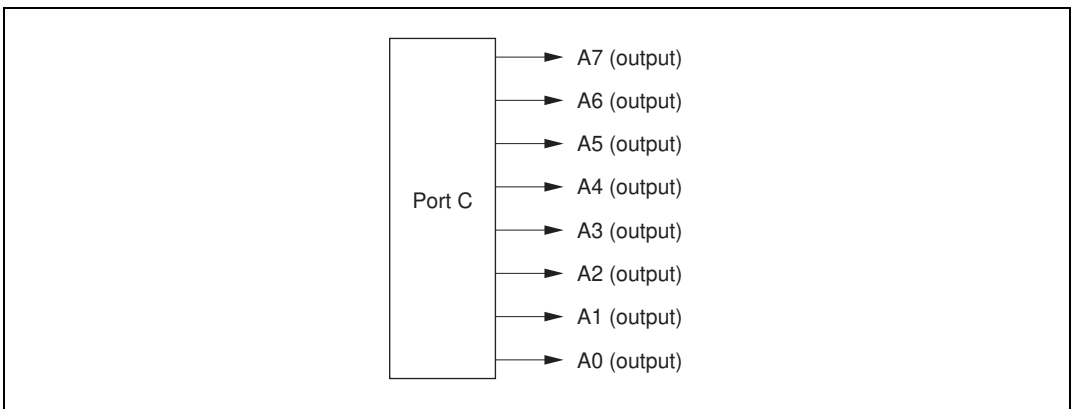

Figure 8.14 Port C Pin Functions (Modes 4 and 5)

Mode 6*: In mode 6, port C pins function as address outputs or input ports. Input or output can be specified on an individual bit basis. Setting PCDDR bits to 1 makes the corresponding port C pins address outputs, while clearing the bits to 0 makes the pins an input ports.

Port C pin functions in mode 6 are shown in figure 8.15.

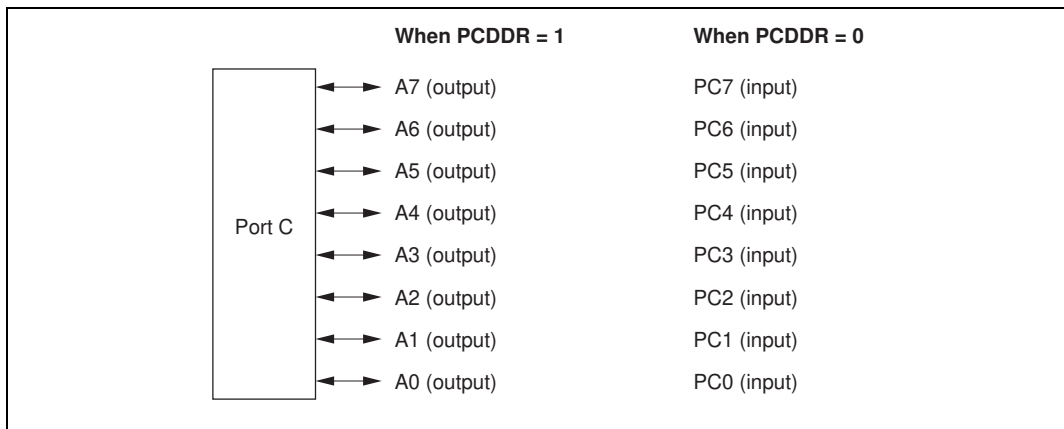

Figure 8.15 Port C Pin Functions (Mode 6)

Mode 7*: In mode 7, port C pins function as I/O ports. Input or output can be specified for each pin on an individual bit basis. Setting PCDDR bits to 1 makes the corresponding port C pins output ports, while clearing the bits to 0 makes the pins input ports.

Port C pin functions in mode 7 are shown in figure 8.16.

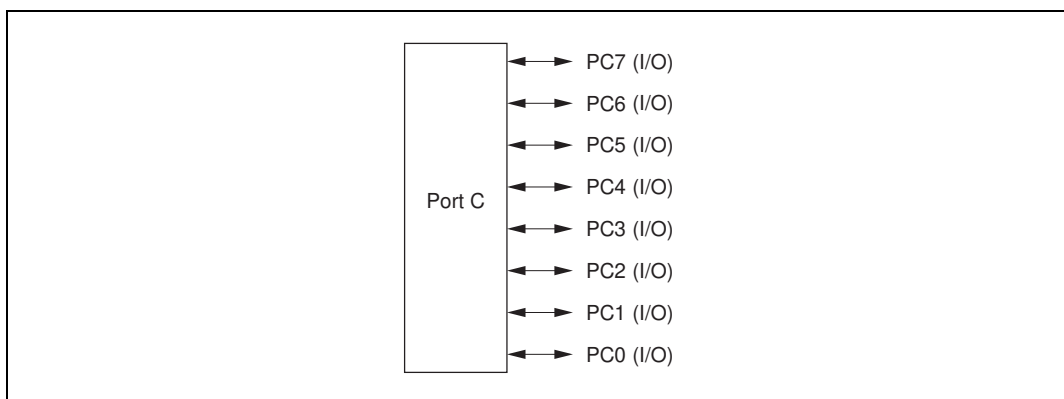

Figure 8.16 Port C Pin Functions (Mode 7)

Note: * Modes 6 and 7 are not available in the ROMless versions.

8.8.4 MOS Input Pull-Up Function

Port C has a built-in MOS input pull-up function that can be controlled by software. This MOS input pull-up function can be used in modes 6 and 7, and can be specified as on or off on an individual bit basis.

When PCDDR bits are cleared to 0 in mode 6 or 7, setting the corresponding PCPCR bits to 1 turns on the MOS input pull-up for that pins.

The MOS input pull-up function is in the off state after a reset, and in hardware standby mode. The prior state is retained in software standby mode.

Table 8.14 summarizes the MOS input pull-up states.

Table 8.14 MOS Input Pull-Up States (Port C)

Modes	Reset	Hardware Standby Mode	Software Standby Mode	In Other Operations
4, 5	OFF	OFF	OFF	OFF
6, 7			ON/OFF	ON/OFF

Legend:

OFF: MOS input pull-up is always off.

ON/OFF: On when PCDDR = 0 and PCPCR = 1; otherwise off.

8.9 Port D

8.9.1 Overview

Port D is an 8-bit I/O port. Port D has a data bus I/O function, and the pin functions change according to the operating mode.

Port D has a built-in MOS input pull-up function that can be controlled by software.

Figure 8.17 shows the port D pin configuration.

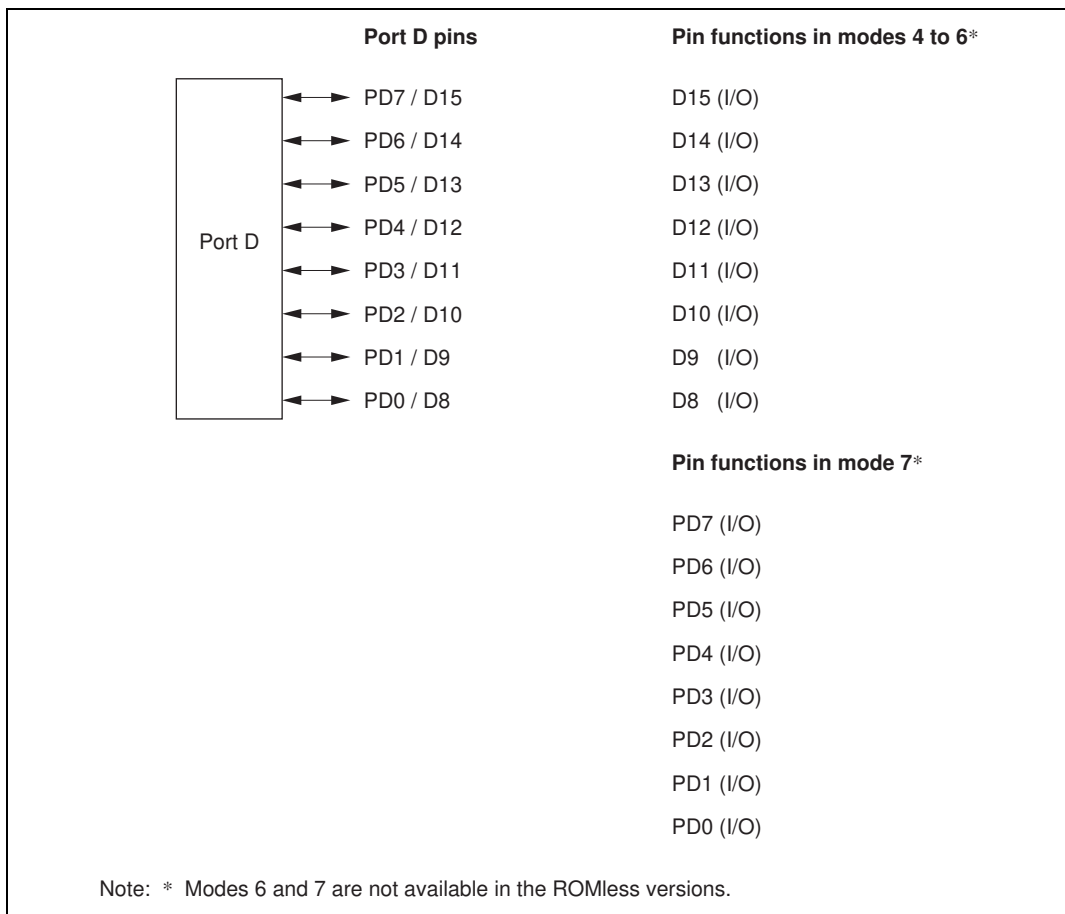

Figure 8.17 Port D Pin Functions

8.9.2 Register Configuration

Table 8.15 shows the port D register configuration.

Table 8.15 Port D Registers

Name	Abbreviation	R/W	Initial Value	Address*
Port D data direction register	PDDDR	W	H'00	H'FEBC
Port D data register	PDDR	R/W	H'00	H'FF6C
Port D register	PORTD	R	Undefined	H'FF5C
Port D MOS pull-up control register	PDPCR	R/W	H'00	H'FF73

Note: * Lower 16 bits of the address.

Port D Data Direction Register (PDDDR)

Bit	:	7	6	5	4	3	2	1	0
		PD7DDR	PD6DDR	PD5DDR	PD4DDR	PD3DDR	PD2DDR	PD1DDR	PD0DDR
Initial value :		0	0	0	0	0	0	0	0
R/W	:	W	W	W	W	W	W	W	W

PDDDR is an 8-bit write-only register, the individual bits of which specify input or output for the pins of port D. PDDDR cannot be read; if it is, an undefined value will be read.

PDDDR is initialized to H'00 by a reset, and in hardware standby mode. It retains its prior state in software standby mode.

- Modes 4 to 6*

The input/output direction specification by PDDDR is ignored, and port D is automatically designated for data I/O.

- Mode 7*

Setting PDDDR bits to 1 makes the corresponding port D pins output ports, while clearing the bits to 0 makes the pins input ports.

Note: * Modes 6 and 7 are not available in the ROMless versions.

Port D Data Register (PDDR)

Bit	:	7	6	5	4	3	2	1	0								
		<table border="1"> <tr> <td>PD7DR</td> <td>PD6DR</td> <td>PD5DR</td> <td>PD4DR</td> <td>PD3DR</td> <td>PD2DR</td> <td>PD1DR</td> <td>PD0DR</td> </tr> </table>								PD7DR	PD6DR	PD5DR	PD4DR	PD3DR	PD2DR	PD1DR	PD0DR
PD7DR	PD6DR	PD5DR	PD4DR	PD3DR	PD2DR	PD1DR	PD0DR										
Initial value	:	0	0	0	0	0	0	0	0								
R/W	:	R/W	R/W	R/W	R/W	R/W	R/W	R/W	R/W								

PDDR is an 8-bit readable/writable register that stores output data for the port D pins (PD7 to PD0).

PDDR is initialized to H'00 by a reset, and in hardware standby mode. It retains its prior state in software standby mode.

Port D Register (PORTD)

Bit	:	7	6	5	4	3	2	1	0								
		<table border="1"> <tr> <td>PD7</td> <td>PD6</td> <td>PD5</td> <td>PD4</td> <td>PD3</td> <td>PD2</td> <td>PD1</td> <td>PD0</td> </tr> </table>								PD7	PD6	PD5	PD4	PD3	PD2	PD1	PD0
PD7	PD6	PD5	PD4	PD3	PD2	PD1	PD0										
Initial value	:	—*	—*	—*	—*	—*	—*	—*	—*								
R/W	:	R	R	R	R	R	R	R	R								

Note: * Determined by state of pins PD7 to PD0.

PORTD is an 8-bit read-only register that shows the pin states. It cannot be written to. Writing of output data for the port D pins (PD7 to PD0) must always be performed on PDDR.

If a port D read is performed while PDDDR bits are set to 1, the PDDR values are read. If a port D read is performed while PDDDR bits are cleared to 0, the pin states are read.

After a reset and in hardware standby mode, PORTD contents are determined by the pin states, as PDDDR and PDDR are initialized. PORTD retains its prior state in software standby mode.

Port D MOS Pull-Up Control Register (PDPCR)

Bit	:	7	6	5	4	3	2	1	0
		PD7PCR	PD6PCR	PD5PCR	PD4PCR	PD3PCR	PD2PCR	PD1PCR	PD0PCR
Initial value	:	0	0	0	0	0	0	0	0
R/W	:	R/W	R/W	R/W	R/W	R/W	R/W	R/W	R/W

PDPCR is an 8-bit readable/writable register that controls the MOS input pull-up function incorporated into port D on an individual bit basis.

When PDDDR bits are cleared to 0 (input port setting) in mode 7, setting the corresponding PDPCR bits to 1 turns on the MOS input pull-up for the corresponding pins.

PDPCR is initialized to H'00 by a reset, and in hardware standby mode. It retains its prior state in software standby mode.

8.9.3 Pin Functions

Modes 4 to 6*: In modes 4 to 6, port D pins are automatically designated as data I/O pins.

Port D pin functions in modes 4 to 6 are shown in figure 8.18.

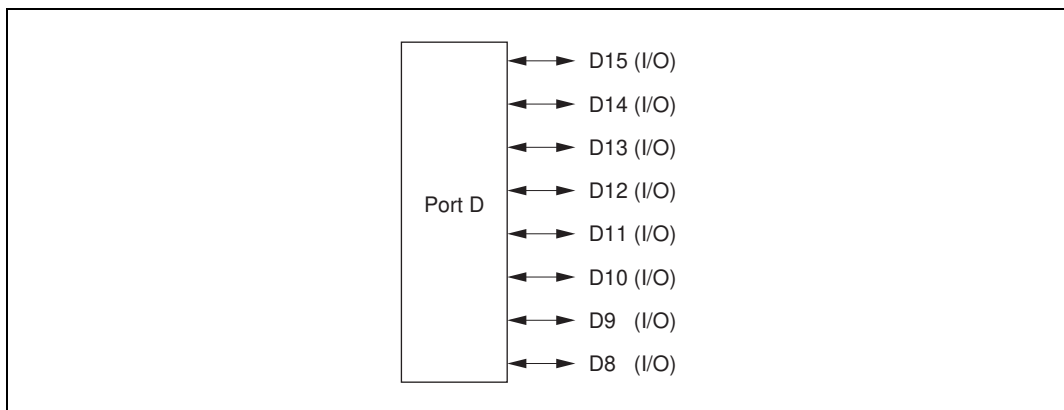

Figure 8.18 Port D Pin Functions (Modes 4 to 6)

Mode 7*: In mode 7, port D pins function as I/O ports. Input or output can be specified for each pin on an individual bit basis. Setting PDDDR bits to 1 makes the corresponding port D pins output ports, while clearing the bits to 0 makes the pins input ports.

Port D pin functions in mode 7 are shown in figure 8.19.

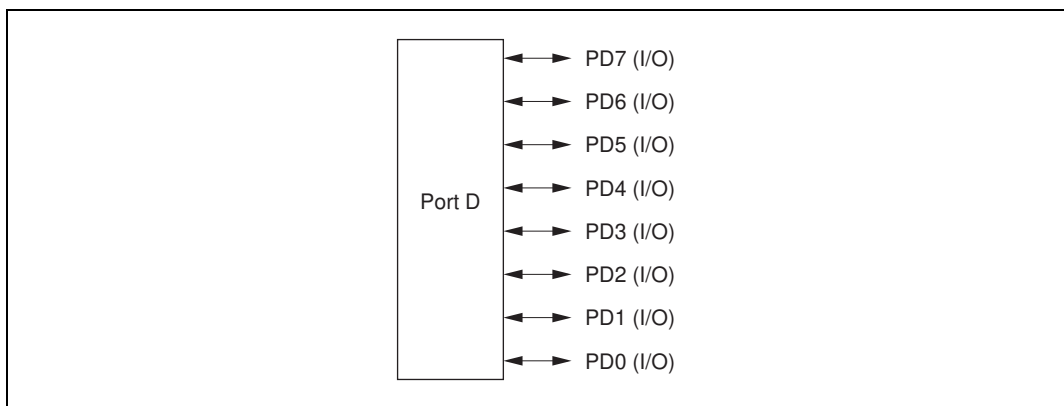

Figure 8.19 Port D Pin Functions (Mode 7)

Note: * Modes 6 and 7 are not available in the ROMless versions.

8.9.4 MOS Input Pull-Up Function

Port D has a built-in MOS input pull-up function that can be controlled by software. This MOS input pull-up function can be used in mode 7, and can be specified as on or off on an individual bit basis.

When PDDDR bits are cleared to 0 in mode 7, setting the corresponding PDPCR bits to 1 turns on the MOS input pull-up for that pins.

The MOS input pull-up function is in the off state after a reset, and in hardware standby mode. The prior state is retained in software standby mode.

Table 8.16 summarizes the MOS input pull-up states.

Table 8.16 MOS Input Pull-Up States (Port D)

Modes	Reset	Hardware Standby Mode	Software Standby Mode	In Other Operations
4 to 6	OFF	OFF	OFF	OFF
7			ON/OFF	ON/OFF

Legend:

OFF: MOS input pull-up is always off.

ON/OFF: On when PDDDR = 0 and PDPCR = 1; otherwise off.

8.10 Port E

8.10.1 Overview

Port E is an 8-bit I/O port. Port E has a data bus I/O function, and the pin functions change according to the operating mode and whether 8-bit or 16-bit bus mode is selected.

Port E has a built-in MOS input pull-up function that can be controlled by software.

Figure 8.20 shows the port E pin configuration.

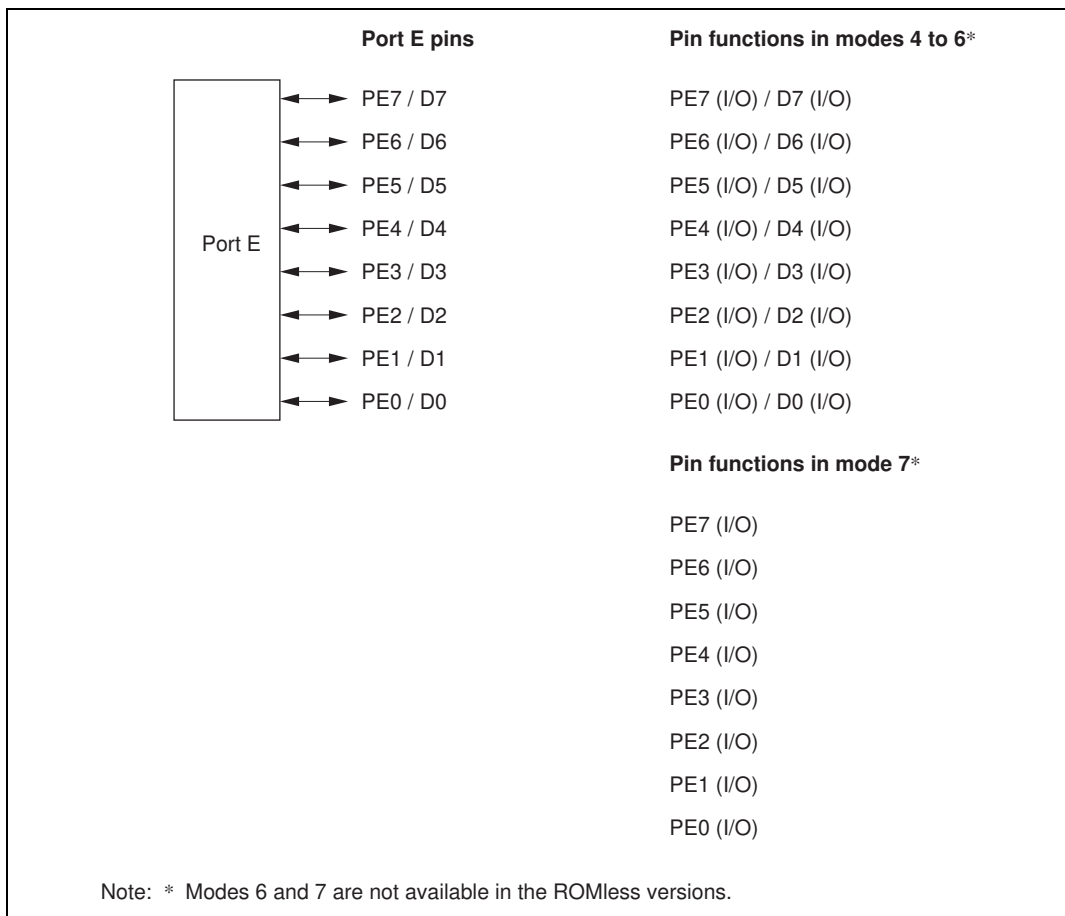

Figure 8.20 Port E Pin Functions

8.10.2 Register Configuration

Table 8.17 shows the port E register configuration.

Table 8.17 Port E Registers

Name	Abbreviation	R/W	Initial Value	Address*
Port E data direction register	PEDDR	W	H'00	H'FEBD
Port E data register	PEDR	R/W	H'00	H'FF6D
Port E register	PORTE	R	Undefined	H'FF5D
Port E MOS pull-up control register	PEPCR	R/W	H'00	H'FF74

Note: * Lower 16 bits of the address.

Port E Data Direction Register (PEDDR)

Bit	:	7	6	5	4	3	2	1	0
		PE7DDR	PE6DDR	PE5DDR	PE4DDR	PE3DDR	PE2DDR	PE1DDR	PE0DDR
Initial value	:	0	0	0	0	0	0	0	0
R/W	:	W	W	W	W	W	W	W	W

PEDDR is an 8-bit write-only register, the individual bits of which specify input or output for the pins of port E. PEDDR cannot be read; if it is, an undefined value will be read.

PEDDR is initialized to H'00 by a reset, and in hardware standby mode. It retains its prior state in software standby mode.

- Modes 4 to 6*

When 8-bit bus mode has been selected, port E pins function as I/O ports. Setting a PEDDR bit to 1 makes the corresponding port E pin an output port, while clearing the bit to 0 makes the pin an input port.

When 16-bit bus mode has been selected, the input/output direction specification by PEDDR is ignored, and port E is designated for data I/O.

For details of 8-bit and 16-bit bus modes, see section 6, Bus Controller.

- Mode 7*

Setting PEDDR bits to 1 makes the corresponding port E pins output ports, while clearing the bits to 0 makes the pins input ports.

Note: * Modes 6 and 7 are not available in the ROMless versions.

Port E Data Register (PEDR)

Bit	:	7	6	5	4	3	2	1	0
		PE7DR	PE6DR	PE5DR	PE4DR	PE3DR	PE2DR	PE1DR	PE0DR
Initial value	:	0	0	0	0	0	0	0	0
R/W	:	R/W	R/W	R/W	R/W	R/W	R/W	R/W	R/W

PEDR is an 8-bit readable/writable register that stores output data for the port E pins (PE7 to PE0).

PEDR is initialized to H'00 by a reset, and in hardware standby mode. It retains its prior state in software standby mode.

Port E Register (PORTE)

Bit	:	7	6	5	4	3	2	1	0
		PE7	PE6	PE5	PE4	PE3	PE2	PE1	PE0
Initial value	:	—*	—*	—*	—*	—*	—*	—*	—*
R/W	:	R	R	R	R	R	R	R	R

Note: * Determined by state of pins PE7 to PE0.

PORTE is an 8-bit read-only register that shows the pin states. It cannot be written to. Writing of output data for the port E pins (PE7 to PE0) must always be performed on PEDR.

If a port E read is performed while PEDDR bits are set to 1, the PEDR values are read. If a port E read is performed while PEDDR bits are cleared to 0, the pin states are read.

After a reset and in hardware standby mode, PORTE contents are determined by the pin states, as PEDDR and PEDR are initialized. PORTE retains its prior state in software standby mode.

Port E MOS Pull-Up Control Register (PEPCR)

Bit	:	7	6	5	4	3	2	1	0
		PE7PCR	PE6PCR	PE5PCR	PE4PCR	PE3PCR	PE2PCR	PE1PCR	PE0PCR
Initial value	:	0	0	0	0	0	0	0	0
R/W	:	R/W	R/W	R/W	R/W	R/W	R/W	R/W	R/W

PEPCR is an 8-bit readable/writable register that controls the MOS input pull-up function incorporated into port E on an individual bit basis.

When PEDDR bits are cleared to 0 (input port setting) in mode 4, 5, or 6 with 8-bit bus mode selected, or in mode 7, setting the corresponding PEPCR bits to 1 turns on the MOS input pull-up for the corresponding pins.

PEPCR is initialized to H'00 by a reset, and in hardware standby mode. It retains its prior state in software standby mode.

8.10.3 Pin Functions

Modes 4 to 6*: In modes 4 to 6, when 8-bit access is designated and 8-bit bus mode is selected, port E pins are automatically designated as I/O ports. Setting PEDDR bits to 1 makes the corresponding port E pins output ports, while clearing the bits to 0 makes the pins input ports.

When 16-bit bus mode is selected, the input/output direction specification by PEDDR is ignored, and port E is designated for data I/O.

Port E pin functions in modes 4 to 6 are shown in figure 8.21.

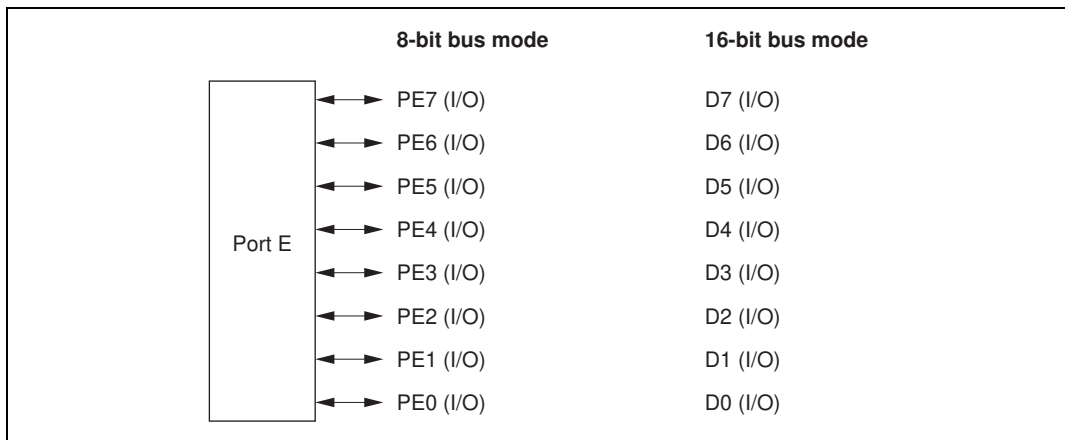

Figure 8.21 Port E Pin Functions (Modes 4 to 6)

Mode 7*: In mode 7, port E pins function as I/O ports. Input or output can be specified for each pin on a bit-by-bit basis. Setting PEDDR bits to 1 makes the corresponding port E pins output ports, while clearing the bits to 0 makes the pins input ports.

Port E pin functions in mode 7 are shown in figure 8.22.

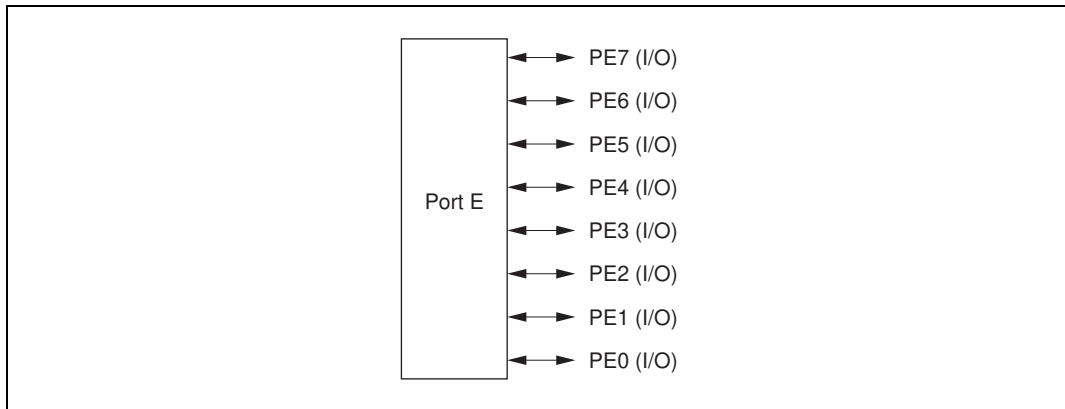

Figure 8.22 Port E Pin Functions (Mode 7)

Note: * Modes 6 and 7 are not available in the ROMless versions.

8.10.4 MOS Input Pull-Up Function

Port E has a built-in MOS input pull-up function that can be controlled by software. This MOS input pull-up function can be used in modes 4, 5, and 6 when 8-bit bus mode is selected, or in mode 7, and can be specified as on or off on an individual bit basis.

When PEDDR bits are cleared to 0 in mode 4, 5, or 6 when 8-bit bus mode is selected, or in mode 7, setting the corresponding PEPCR bits to 1 turns on the MOS input pull-up for that pins.

The MOS input pull-up function is in the off state after a reset, and in hardware standby mode. The prior state is retained in software standby mode.

Table 8.18 summarizes the MOS input pull-up states.

Table 8.18 MOS Input Pull-Up States (Port E)

Modes	Reset	Hardware Standby Mode	Software Standby Mode	In Other Operations
7	OFF	OFF	ON/OFF	ON/OFF
4 to 6				
			8-bit bus	
			16-bit bus	
			OFF	OFF

Legend:

OFF: MOS input pull-up is always off.

ON/OFF: On when PEDDR = 0 and PEPCR = 1; otherwise off.

8.11 Port F

8.11.1 Overview

Port F is an 8-bit I/O port. Port F pins also function as bus control signal input/output pins (\overline{AS} , \overline{RD} , \overline{HWR} , \overline{LWR} , \overline{WAIT} , \overline{BREQ} , \overline{BACK} , \overline{BREQO} , $\overline{CS4}$, and $\overline{CS5}$), the system clock (ϕ) output pin and interrupt input pins ($\overline{IRQ0}$ to $\overline{IRQ3}$).

The interrupt input pins ($\overline{IRQ0}$ to $\overline{IRQ3}$) are Schmitt-triggered inputs.

Figure 8.23 shows the port F pin configuration.

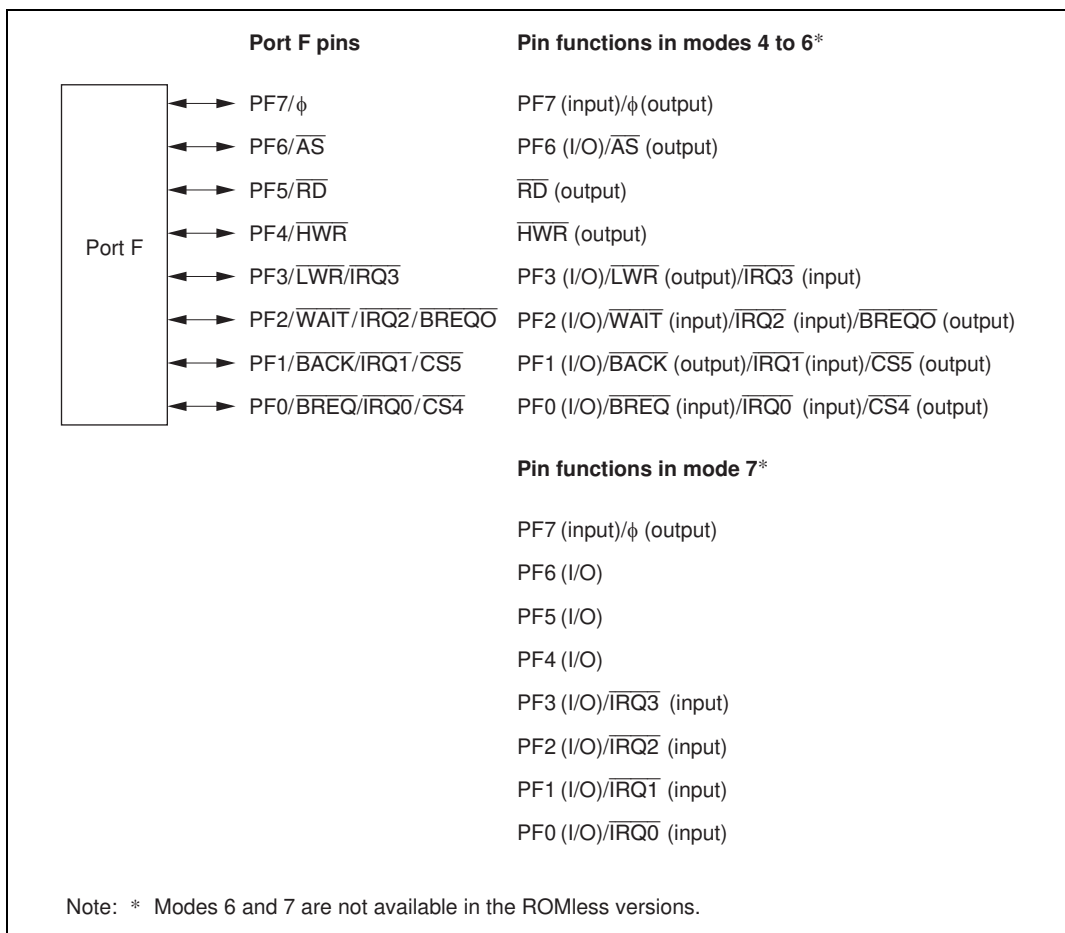

Figure 8.23 Port F Pin Functions

8.11.2 Register Configuration

Table 8.19 shows the port F register configuration.

Table 8.19 Port F Registers

Name	Abbreviation	R/W	Initial Value	Address* ¹
Port F data direction register	PFDDR	W	H'80/H'00* ²	H'FEBE
Port F data register	PFDR	R/W	H'00	H'FF6E
Port F register	PORTF	R	Undefined	H'FF5E
Bus control register L	BCRL	R/W	H'3C	H'FED5
System control register	SYSCR	R/W	H'01	H'FF39
Port function control register 1	PFCR1	R/W	H'0F	H'FF45
Port function control register 2	PFCR2	R/W	H'30	H'FFAC

Notes: 1. Lower 16 bits of the address.
2. Initial value depends on the mode.

Port F Data Direction Register (PFDDR)

Bit	:	7	6	5	4	3	2	1	0
		PF7DDR	PF6DDR	PF5DDR	PF4DDR	PF3DDR	PF2DDR	PF1DDR	PF0DDR

Modes 4 to 6*

Initial value :	1	0	0	0	0	0	0	0	0
R/W :	W	W	W	W	W	W	W	W	W

Mode 7*

Initial value :	0	0	0	0	0	0	0	0	0
R/W :	W	W	W	W	W	W	W	W	W

PFDDR is an 8-bit write-only register, the individual bits of which specify input or output for the pins of port F. PFDDR cannot be read; if it is, an undefined value will be read.

PFDDR is initialized by a reset, and in hardware standby mode, to H'80 in modes 4 to 6*, and to H'00 in mode 7*. It retains its prior state in software standby mode. The OPE bit in SBYCR is used to select whether the bus control output pins retain their output state or become high-impedance when a transition is made to software standby mode.

Note: * Modes 6 and 7 are not available in the ROMless versions.

Port F Data Register (PFDR)

Bit	:	7	6	5	4	3	2	1	0
		PF7DR	PF6DR	PF5DR	PF4DR	PF3DR	PF2DR	PF1DR	PF0DR
Initial value	:	0	0	0	0	0	0	0	0
R/W	:	R/W	R/W	R/W	R/W	R/W	R/W	R/W	R/W

PFDR is an 8-bit readable/writable register that stores output data for the port F pins (PF7 to PF0).

PFDR is initialized to H'00 by a reset, and in hardware standby mode. It retains its prior state in software standby mode.

Port F Register (PORTF)

Bit	:	7	6	5	4	3	2	1	0
		PF7	PF6	PF5	PF4	PF3	PF2	PF1	PF0
Initial value	:	—*	—*	—*	—*	—*	—*	—*	—*
R/W	:	R	R	R	R	R	R	R	R

Note: * Determined by state of pins PF7 to PF0.

PORTF is an 8-bit read-only register that shows the pin states, and cannot be modified. Writing of output data for the port F pins (PF7 to PF0) must always be performed on PFDR.

If a port F read is performed while PFDDR bits are set to 1, the PFDR values are read. If a port F read is performed while PFDDR bits are cleared to 0, the pin states are read.

After a reset and in hardware standby mode, PORTF contents are determined by the pin states, as PFDDR and PFDR are initialized. PORTF retains its prior state in software standby mode.

Port Function Control Register 1 (PFCR1)

Bit	:	7	6	5	4	3	2	1	0
		CSS17	CSS36	PF1CS5S	PF0CS4S	A23E	A22E	A21E	A20E
Initial value	:	0	0	0	0	1	1	1	1
R/W	:	R/W	R/W	R/W	R/W	R/W	R/W	R/W	R/W

PFCR1 is an 8-bit readable/writable register that performs I/O port control. PFCR1 is initialized to H'0F by a reset, and in hardware standby mode.

Bit 7—CS17 Select (CSS17): Selects whether $\overline{CS1}$ or $\overline{CS7}$ is output from the PG3 pin. For details, see section 8.12, Port G.

Bit 6—CS36 Select (CSS36): Selects whether $\overline{CS3}$ or $\overline{CS6}$ is output from the PG1 pin. For details, see section 8.12, Port G.

Bit 5—Port F1 Chip Select 5 Select (PF1CS5S): Selects enabling or disabling of $\overline{CS5}$ output. This bit is valid in modes 4 to 6.

Bit 5

PF1CS5S	Description
0	PF1 is the PF1/ \overline{BACK} / $\overline{IRQ1}$ pin (Initial value)
1	PF1 is the PF1/ \overline{BACK} / $\overline{IRQ1}$ / $\overline{CS5}$ pin. $\overline{CS5}$ output is enabled when BRLE = 0, CS25E = 1, and PF1DDR = 1

Bit 4—Port F0 Chip Select 4 Select (PF0CS4S): Selects enabling or disabling of $\overline{CS4}$ output. This bit is valid in modes 4 to 6.

Bit 4

PF0CS4S	Description
0	PF0 is the PF0/ \overline{BREQ} / $\overline{IRQ0}$ pin (Initial value)
1	PF0 is the PF0/ \overline{BREQ} / $\overline{IRQ0}$ / $\overline{CS4}$ pin. $\overline{CS4}$ output is enabled when BRLE = 0, CS25E = 1, and PF0DDR = 1

Bit 3—Address 23 Enable (A23E): Enables or disables address output 23 (A23). For details, see section 8.2, Port 1.

Bit 2—Address 22 Enable (A22E): Enables or disables address output 22 (A22). For details, see section 8.2, Port 1.

Bit 1—Address 21 Enable (A21E): Enables or disables address output 21 (A21). For details, see section 8.2, Port 1.

Bit 0—Address 20 Enable (A20E): Enables or disables address output 20 (A20). For details, see section 8.2, Port 1.

Port Function Control Register 2 (PFCR2)

Bit	:	7	6	5	4	3	2	1	0
		—	—	CS167E	CS25E	ASOD	—	—	—
Initial value	:	0	0	1	1	0	0	0	0
R/W	:	R/W	R/W	R/W	R/W	R/W	R	R	R

PFCR2 is an 8-bit readable/writable register that performs I/O port control. PFCR2 is initialized to H'30 by a reset, and in hardware standby mode.

Bits 7 and 6—Reserved: Only 0 should be written to these bits.

Bit 5—CS167 Enable (CS167E): Enables or disables $\overline{CS1}$, $\overline{CS6}$, and $\overline{CS7}$ output. For details, see section 8.12, Port G.

Bit 4—CS25 Enable (CS25E): Enables or disables $\overline{CS2}$, $\overline{CS3}$, $\overline{CS4}$, and $\overline{CS5}$ output. Change the CS25E setting only when the DDR bits are cleared to 0. This bit is valid in modes 4 to 6.

Bit 4

CS25E	Description
0	$\overline{CS2}$, $\overline{CS3}$, $\overline{CS4}$, and $\overline{CS5}$ output disabled (can be used as I/O ports)
1	$\overline{CS2}$, $\overline{CS3}$, $\overline{CS4}$, and $\overline{CS5}$ output enabled (Initial value)

Bit 3—AS Output Disable (ASOD): Enables or disables \overline{AS} output. This bit is valid in modes 4 to 6.

Bit 3

ASOD	Description
0	PF6 is used as \overline{AS} output pin (Initial value)
1	PF6 is designated as I/O port, and does not function as \overline{AS} output pin

Bits 2 to 0—Reserved: When read, these bits are always read as 0.

System Control Register (SYSCR)

Bit	:	7	6	5	4	3	2	1	0
		—	—	INTM1	INTM0	NMIEG	LWROD	—	RAME
Initial value	:	0	0	0	0	0	0	0	1
R/W	:	R/W	—	R/W	R/W	R/W	R/W	R/W	R/W

Bit 2—LWR Output Disable (LWROD): Enables or disables $\overline{\text{LWR}}$ output. This bit is valid in modes 4 to 6.

Bit 2

LWROD	Description
0	PF3 is designated as $\overline{\text{LWR}}$ output pin (Initial value)
1	PF3 is designated as I/O port, and does not function as $\overline{\text{LWR}}$ output pin

Bus Control Register L (BCRL)

Bit	:	7	6	5	4	3	2	1	0
		BRLE	BREQOE	EAE	—	—	—	—	WAITE
Initial value	:	0	0	1	1	1	1	0	0
R/W	:	R/W	R/W	R/W	R/W	R/W	R/W	R/W	R/W

BCRL is an 8-bit readable/writable register that performs selection of the external bus-released state protocol, selection of the area partition unit, and enabling or disabling of $\overline{\text{WAIT}}$ pin input.

BCRL is initialized to H'3C by a reset, and in hardware standby mode. It is not initialized in software standby mode.

Bit 7—Bus Release Enable (BRLE): Enables or disables external bus release.

Bit 7

BRLE	Description
0	External bus release disabled. $\overline{\text{BREQ}}$, $\overline{\text{BACK}}$, and $\overline{\text{BREQO}}$ pins can be used as I/O ports (Initial value)
1	External bus release enabled

Bit 6—BREQO Pin Enable (BREQOE): Outputs a signal that requests the external bus master to drop the bus request signal ($\overline{\text{BREQ}}$) in the external bus-released state, or when an internal bus master performs an external space access.

Bit 6

BREQOE	Description
0	$\overline{\text{BREQO}}$ output disabled. $\overline{\text{BREQO}}$ pin can be used as I/O port (Initial value)
1	$\overline{\text{BREQO}}$ output enabled

Bit 0—WAIT Pin Enable (WAITE): Selects enabling or disabling of wait input by the $\overline{\text{WAIT}}$ pin.

Bit 0

WAITE	Description
0	Wait input by $\overline{\text{WAIT}}$ pin disabled. $\overline{\text{WAIT}}$ pin can be used as I/O port (Initial value)
1	Wait input by $\overline{\text{WAIT}}$ pin enabled

8.11.3 Pin Functions

Port F pins also function as bus control signal input/output pins (\overline{AS} , \overline{RD} , \overline{HWR} , \overline{LWR} , \overline{WAIT} , \overline{BREQ} , \overline{BACK} , \overline{BREQO} , $\overline{CS4}$, and $\overline{CS5}$) the system clock (ϕ) output pin and interrupt input pins ($\overline{IRQ0}$ to $\overline{IRQ3}$). The pin functions differ between modes 4 to 6^{*1}, and mode 7^{*1}. Port F pin functions are shown in table 8.20.

Table 8.20 Port F Pin Functions

Pin Selection Method and Pin Functions

PF7/ ϕ

The pin function is switched as shown below according to bit PF7DDR.

PF7DDR	0	1
Pin function	PF7 input pin	ϕ output pin

PF6/ \overline{AS}

The pin function is switched as shown below according to the operating mode, and bit PF6DDR, and bit ASOD in PFCR2.

Operating Mode	Modes 4 to 6 ^{*1}			Mode 7 ^{*1}	
ASOD	0	1		—	
PF6DDR	—	0	1	0	1
Pin function	\overline{AS} output pin	PF6 input pin	PF6 output pin	PF6 input pin	PF6 output pin

PF5/ \overline{RD}

The pin function is switched as shown below according to the operating mode and bit PF5DDR.

Operating Mode	Modes 4 to 6 ^{*1}	Mode 7 ^{*1}	
PF5DDR	—	0	1
Pin function	\overline{RD} output pin	PF5 input pin	PF5 output pin

PF4/ \overline{HWR}

The pin function is switched as shown below according to the operating mode and bit PF4DDR.

Operating Mode	Modes 4 to 6 ^{*1}	Mode 7 ^{*1}	
PF4DDR	—	0	1
Pin function	\overline{HWR} output pin	PF4 input pin	PF4 output pin

Pin Selection Method and Pin FunctionsPF3/ $\overline{\text{LWR}}$ / $\overline{\text{IRQ3}}$

The pin function is switched as shown below according to the operating mode, and bit PF3DDR, and bit LWROD in SYSCR.

Operating Mode	Modes 4 to 6 ^{*1}				Mode 7 ^{*1}	
LWROD	0		1 ^{*3}		—	
PF3DDR	—		0	1	0	1
Pin function	$\overline{\text{LWR}}$ output pin		PF3 input pin	PF3 output pin	PF3 input pin	PF3 output pin
	$\overline{\text{IRQ3}}$ interrupt input pin ^{*2}					

PF2/ $\overline{\text{WAIT}}$ / $\overline{\text{IRQ2}}$ /
BREQO

The pin function is switched as shown below according to the operating mode, and WAITE bit, BREQOE bit in BCRL and PF2DDR bit.

Operating Mode	Modes 4 to 6 ^{*1}						Mode 7 ^{*1}	
BREQOE	0				1		—	
WAITE	0		1		0	1	—	
PF2DDR	0	1	0	1	—	—	0	1
Pin function	PF2 input pin	PF2 output pin	$\overline{\text{WAIT}}$ input pin	Setting prohibited	$\overline{\text{BREQO}}$ output pin	Setting prohibited	PF2 input pin	PF2 output pin
	$\overline{\text{IRQ2}}$ interrupt input pin ^{*2}							

Pin Selection Method and Pin Functions

PF1/ $\overline{\text{BACK}}$ / $\overline{\text{IRQ1}}$ / $\overline{\text{CS5}}$ The pin function is switched as shown below according to the operating mode, and the BRLE bit in BCRL, PF1CS5S bit in PFCR1, and CS25E bit in PFCR2 and PF1DDR bit.

Operating Mode	Modes 4 to 6* ¹				Mode 7* ¹	
BRLE	0			1	—	
PF1DDR	0	1		—	0	1
CS25E	—	0	1		—	—
PF1CS5S	—	—	0	1	—	—
Pin function	PF1 input pin	PF1 output pin		$\overline{\text{CS5}}$ output pin	$\overline{\text{BACK}}$ output pin	PF1 input pin
	$\overline{\text{IRQ1}}$ interrupt input pin* ²					

PF0/ $\overline{\text{BREQ}}$ / $\overline{\text{IRQ0}}$ / $\overline{\text{CS4}}$ The pin function is switched as shown below according to the operating mode, and the BRLE bit in BCRL and PF0CS4S bit in PFCR1 and CS25E bit in PFCR2 and PF0DDR bit.

Operating Mode	Modes 4 to 6* ¹				Mode 7* ¹	
BRLE	0			1	—	
PF0DDR	0	1		—	0	1
CS25E	—	0	1		—	—
PF0CS4S	—	—	0	1	—	—
Pin function	PF0 input pin	PF0 output pin		$\overline{\text{CS4}}$ output pin	$\overline{\text{BREQ}}$ output pin	PF0 input pin
	$\overline{\text{IRQ0}}$ interrupt input pin* ²					

- Notes:
1. Modes 6 and 7 are not available in the ROMless versions.
 2. When this pin is used as an external interrupt input, the pin function should be set as a port (PFn) input pin.
 3. Valid only in 8-bit-bus mode.

8.12 Port G

8.12.1 Overview

Port G is a 5-bit I/O port. Port G pins also function as bus control signal output pins ($\overline{CS0}$ to $\overline{CS3}$, $\overline{CS6}$, $\overline{CS7}$). The A/D converter input pin (\overline{ADTRG}), and interrupt input pins ($\overline{IRQ6}$, $\overline{IRQ7}$). The interrupt input pins ($\overline{IRQ6}$, $\overline{IRQ7}$) are Schmitt-triggered inputs.

Figure 8.24 shows the port G pin configuration.

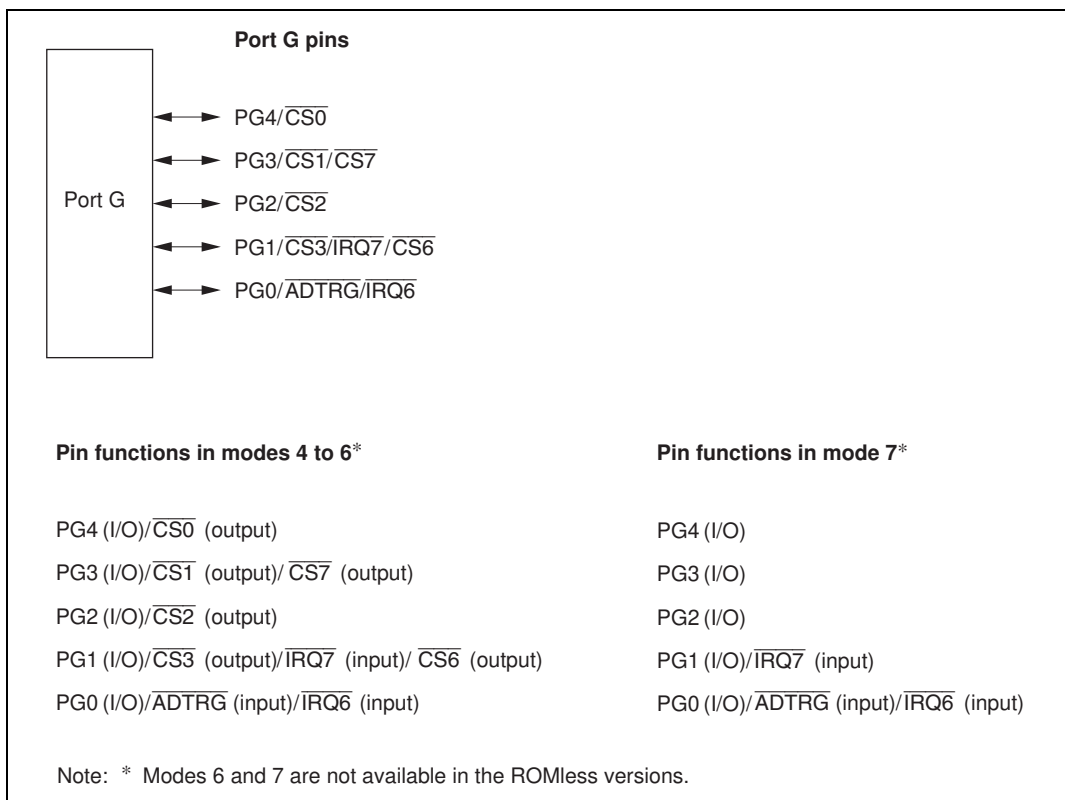

Figure 8.24 Port G Pin Functions

8.12.2 Register Configuration

Table 8.21 shows the port G register configuration.

Table 8.21 Port G Registers

Name	Abbreviation	R/W	Initial Value* ¹	Address* ²
Port G data direction register	PGDDR	W	H'10/H'00* ³	H'FEBF
Port G data register	PGDR	R/W	H'00	H'FF6F
Port G register	PORTG	R	Undefined	H'FF5F
Port function control register 1	PFCR1	R/W	H'0F	H'FF45
Port function control register 2	PFCR2	R/W	H'30	H'FFAC

- Notes: 1. Value of bits 4 to 0.
 2. Lower 16 bits of the address.
 3. Initial value depends on the mode.

Port G Data Direction Register (PGDDR)

Bit	:	7	6	5	4	3	2	1	0
		—	—	—	PG4DDR	PG3DDR	PG2DDR	PG1DDR	PG0DDR

Modes 4 and 5

Initial value	:	Undefined	Undefined	Undefined	1	0	0	0	0
R/W	:	—	—	—	W	W	W	W	W

Modes 6 and 7*

Initial value	:	Undefined	Undefined	Undefined	0	0	0	0	0
R/W	:	—	—	—	W	W	W	W	W

PGDDR is an 8-bit write-only register, the individual bits of which specify input or output for the pins of port G. PGDDR cannot be read, and bits 7 to 5 are reserved. If PGDDR is read, an undefined value will be read.

The PGDDR is initialized by a reset and in hardware standby mode, to H'10 (bits 4 to 0) in modes 4 and 5, and to H'00 (bits 4 to 0) in modes 6 and 7*. It retains its prior state in software standby mode. The OPE bit in SBYCR is used to select whether the bus control output pins retain their output state or become high-impedance when a transition is made to software standby mode.

Note: * Modes 6 and 7 are not available in the ROMless versions.

Port G Data Register (PGDR)

Bit	:	7	6	5	4	3	2	1	0
		—	—	—	PG4DR	PG3DR	PG2DR	PG1DR	PG0DR
Initial value	:	Undefined	Undefined	Undefined	0	0	0	0	0
R/W	:	—	—	—	R/W	R/W	R/W	R/W	R/W

PGDR is an 8-bit readable/writable register that stores output data for the port G pins (PG4 to PG0).

Bits 7 to 5 are reserved; they return an undetermined value if read, and cannot be modified.

PGDR is initialized to H'00 (bits 4 to 0) by a reset, and in hardware standby mode. It retains its prior state in software standby mode.

Port G Register (PORTG)

Bit	:	7	6	5	4	3	2	1	0
		—	—	—	PG4	PG3	PG2	PG1	PG0
Initial value	:	Undefined	Undefined	Undefined	—*	—*	—*	—*	—*
R/W	:	—	—	—	R	R	R	R	R

Note: * Determined by state of pins PG4 to PG0.

PORTG is an 8-bit read-only register that shows the pin states. It cannot be written to. Writing of output data for the port G pins (PG4 to PG0) must always be performed on PGDR.

Bits 7 to 5 are reserved; they return an undetermined value if read, and cannot be modified.

If a port G read is performed while PGDDR bits are set to 1, the PGDR values are read. If a port G read is performed while PGDDR bits are cleared to 0, the pin states are read.

After a reset and in hardware standby mode, PORTG contents are determined by the pin states, as PGDDR and PGDR are initialized. PORTG retains its prior state in software standby mode.

Port Function Control Register 1 (PFCR1)

Bit	:	7	6	5	4	3	2	1	0
		CSS17	CSS36	PF1CS5S	PF0CS4S	A23E	A22E	A21E	A20E
Initial value	:	0	0	0	0	1	1	1	1
R/W	:	R/W	R/W	R/W	R/W	R/W	R/W	R/W	R/W

PFCR1 is an 8-bit readable/writable register that performs I/O port control. PFCR1 is initialized to H'0F by a reset, and in hardware standby mode.

Bit 7—CS17 Select (CSS17): Selects whether $\overline{CS1}$ or $\overline{CS7}$ is output from the PG3 pin. Change the CSS17 bit setting only when the corresponding DDR bit is 0. This bit is valid in modes 4 to 6.

Bit 7

CSS17	Description
0	PG3 is the PG3/ $\overline{CS1}$ pin. $\overline{CS1}$ output is enabled when CS167E = 1 and PG3DDR = 1 (Initial value)
1	PG3 is the PG3/ $\overline{CS7}$ pin. $\overline{CS7}$ output is enabled when CS167E = 1 and PG3DDR = 1

Bit 6—CS36 Select (CSS36): Selects whether $\overline{CS3}$ or $\overline{CS6}$ is output from the PG1 pin. Change the CSS36 bit setting only when the corresponding DDR bit is 0. This bit is valid in modes 4 to 6.

Bit 6

CSS36	Description
0	PG1 is the PG1/ $\overline{IRQ7}/\overline{CS3}$ pin. $\overline{CS3}$ output is enabled when CS25E = 1 and PG1DDR = 1 (Initial value)
1	PG1 is the PG1/ $\overline{IRQ7}/\overline{CS6}$ pin. $\overline{CS6}$ output is enabled when CS167E = 1 and PG1DDR = 1

Bit 5—Port F1 Chip Select 5 Select (PF1CS5S): Enables or disables $\overline{CS5}$ output. For details, see section 8.11, Port F.

Bit 4—Port F0 Chip Select 4 Select (PF0CS4S): Enables or disables $\overline{CS4}$ output. For details, see section 8.11, Port F.

Bit 3—Address 23 Enable (A23E): Enables or disables address output 23 (A23). For details, see section 8.2, Port 1.

Bit 2—Address 22 Enable (A22E): Enables or disables address output 22 (A22). For details, see section 8.2, Port 1.

Bit 1—Address 21 Enable (A21E): Enables or disables address output 21 (A21). For details, see section 8.2, Port 1.

Bit 0—Address 20 Enable (A20E): Enables or disables address output 20 (A20). For details, see section 8.2, Port 1.

Port Function Control Register 2 (PFCR2)

Bit	:	7	6	5	4	3	2	1	0
		—	—	CS167E	CS25E	ASOD	—	—	—
Initial value	:	0	0	1	1	0	0	0	0
R/W	:	R/W	R/W	R/W	R/W	R/W	R	R	R

PFCR2 is an 8-bit readable/writable register that performs I/O port control. PFCR2 is initialized to H'30 by a reset, and in hardware standby mode. This bit is valid in modes 4 to 6.

Bits 7 and 6—Reserved: Only 0 should be written to these bits.

Bit 5—CS167 Enable (CS167E): Enables or disables $\overline{CS1}$, $\overline{CS6}$, and $\overline{CS7}$ output. Change the CS167E setting only when the DDR bits are cleared to 0.

Bit 5

CS167E	Description
0	$\overline{CS1}$, $\overline{CS6}$, and $\overline{CS7}$ output disabled (can be used as I/O ports)
1	$\overline{CS1}$, $\overline{CS6}$, and $\overline{CS7}$ output enabled (Initial value)

Bit 4—CS25 Enable (CS25E): Enables or disables $\overline{CS2}$, $\overline{CS3}$, $\overline{CS4}$, and $\overline{CS5}$ output. Change the CS25E setting only when the DDR bits are cleared to 0. This bit is valid in modes 4 to 6.

Bit 4

CS25E	Description
0	$\overline{CS2}$, $\overline{CS3}$, $\overline{CS4}$, and $\overline{CS5}$ output disabled (can be used as I/O ports)
1	$\overline{CS2}$, $\overline{CS3}$, $\overline{CS4}$, and $\overline{CS5}$ output enabled (Initial value)

Bit 3—AS Output Disable (ASOD): Enables or disables \overline{AS} output. This bit is valid in modes 4 to 6. For details, see section 8.11, Port F.

Bits 2 to 0—Reserved: When read, these bits are always read as 0.

8.12.3 Pin Functions

Port G pins also function as bus control signal output pins ($\overline{CS0}$ to $\overline{CS3}$, $\overline{CS6}$, $\overline{CS7}$) the A/D converter input pin (\overline{ADTRG}), and interrupt input pins ($\overline{IRQ6}$, $\overline{IRQ7}$). The pin functions are different in mode 7*¹, and modes 4 to 6*¹. Port G pin functions are shown in table 8.22.

Table 8.22 Port G Pin Functions

Pin Selection Method and Pin Functions

PG4/ $\overline{CS0}$

The pin function is switched as shown below according to the operating mode and bit PG4DDR.

Operating Mode	Modes 4 to 6* ¹		Mode 7* ¹	
PG4DDR	0	1	0	1
Pin function	PG4 input pin	$\overline{CS0}$ output pin	PG4 input pin	PG4 output pin

PG3/ $\overline{CS1}$ / $\overline{CS7}$

The pin function is switched as shown below according to the operating mode and CSS17 bit in PFCR1, CS167E bit in PFCR2, and bit PG3DDR.

Operating Mode	Modes 4 to 6* ¹				Mode 7* ¹	
PG3DDR	0	1		0	1	
CS167E	—	0	1		—	—
CSS17	—	—	0	1	—	—
Pin function	PG3 input pin	PG3 output pin	$\overline{CS1}$ output pin	$\overline{CS7}$ output pin	PG3 input pin	PG3 output pin

PG2/ $\overline{CS2}$

The pin function is switched as shown below according to the operating mode and CS25E bit in PFCR2, and bit PG2DDR.

Operating Mode	Modes 4 to 6* ¹			Mode 7* ¹	
PG2DDR	0	1		0	1
CS25E	—	0	1	—	—
Pin function	PG2 input pin	PG2 output pin	$\overline{CS2}$ output pin	PG2 input pin	PG2 output pin

Pin Selection Method and Pin Functions

**PG1/ $\overline{\text{CS3}}$ / $\overline{\text{CS6}}$ /
 $\overline{\text{IRQ7}}$**

The pin function is switched as shown below according to the combination of operating mode and CSS36 bit in PFCR1, CS167E bit in PFCR2, CS25E bit and bit PG1DDR.

Operating Mode	Modes 4 to 6* ¹								Mode 7* ¹		
	PG1DDR	0	1								0
CS167E	—	0				1				—	—
CS25E	—	0	1		0		1		—	—	
CSS36	—	—	0	1	0	1	0	1	—	—	
Pin function	PG1 input pin	PG1 output pin	$\overline{\text{CS3}}$ output pin	PG1 output pin		$\overline{\text{CS6}}$ output pin	$\overline{\text{CS3}}$ output pin	$\overline{\text{CS6}}$ output pin	PG1 input pin	PG1 output pin	
	$\overline{\text{IRQ7}}$ interrupt input pin* ²										

PG0/ $\overline{\text{ADTRG}}$ / $\overline{\text{IRQ6}}$ The pin function is switched as shown below according to the combination of bits TRGS1 and TRGS0 (trigger select 1 and 0) in the A/D control register (ADCR).

PG0DDR	0		1	
Pin function	PG0 input		PG0 output	
	$\overline{\text{ADTRG}}$ input pin* ³			
	$\overline{\text{IRQ6}}$ interrupt input pin* ²			

- Notes:
1. Modes 6 and 7 are not available in the ROMless versions.
 2. When this pin is used as an external interrupt input, it should not be used as an input/output pin with other functions.
 3. $\overline{\text{ADTRG}}$ input when TRGS1 = TRGS0 = 1.

Section 9 16-Bit Timer Pulse Unit (TPU)

9.1 Overview

The chip has an on-chip 16-bit timer pulse unit (TPU) that comprises six 16-bit timer channels.

9.1.1 Features

- Maximum 16-pulse input/output
 - A total of 16 timer general registers (TGRs) are provided (four each for channels 0 and 3, and two each for channels 1, 2, 4, and 5), each of which can be set independently as an output compare/input capture register
 - TGRC and TGRD for channels 0 and 3 can also be used as buffer registers
- Selection of 8 counter input clocks for each channel
- The following operations can be set for each channel:
 - Waveform output at compare match: Selection of 0, 1, or toggle output
 - Input capture function: Selection of rising edge, falling edge, or both edge detection
 - Counter clear operation: Counter clearing possible by compare match or input capture
 - Synchronous operation: Multiple timer counters (TCNT) can be written to simultaneously
 - Simultaneous clearing by compare match and input capture possible
 - Register simultaneous input/output possible by counter synchronous operation
 - PWM mode: Any PWM output duty can be set
 - Maximum of 15-phase PWM output possible by combination with synchronous operation
- Buffer operation settable for channels 0 and 3
 - Input capture register double-buffering possible
 - Automatic rewriting of output compare register possible
- Phase counting mode settable independently for each of channels 1, 2, 4, and 5
 - Two-phase encoder pulse up/down-count possible
- Cascaded operation
 - Channel 2 (channel 5) input clock operates as 32-bit counter by setting channel 1 (channel 4) overflow/underflow
- Fast access via internal 16-bit bus
 - Fast access is possible via a 16-bit bus interface

- 26 interrupt sources
 - For channels 0 and 3, four compare match/input capture dual-function interrupts and one overflow interrupt can be requested independently
 - For channels 1, 2, 4, and 5, two compare match/input capture dual-function interrupts, one overflow interrupt, and one underflow interrupt can be requested independently
- Automatic transfer of register data
 - Block transfer, 1-word data transfer, and 1-byte data transfer possible by data transfer controller (DTC) activation
- A/D converter conversion start trigger can be generated
 - Channel 0 to 5 compare match A/input capture A signals can be used as A/D converter conversion start trigger
- Module stop mode can be set
 - As the initial setting, TPU operation is halted. Register access is enabled by exiting module stop mode

Table 9.1 lists the functions of the TPU.

Table 9.1 TPU Functions

Item	Channel 0	Channel 1	Channel 2	Channel 3	Channel 4	Channel 5
Count clock	$\phi/1$	$\phi/1$	$\phi/1$	$\phi/1$	$\phi/1$	$\phi/1$
	$\phi/4$	$\phi/4$	$\phi/4$	$\phi/4$	$\phi/4$	$\phi/4$
	$\phi/16$	$\phi/16$	$\phi/16$	$\phi/16$	$\phi/16$	$\phi/16$
	$\phi/64$	$\phi/64$	$\phi/64$	$\phi/64$	$\phi/64$	$\phi/64$
	TCLKA	$\phi/256$	$\phi/1024$	$\phi/256$	$\phi/1024$	$\phi/256$
	TCLKB	TCLKA	TCLKA	$\phi/1024$	TCLKA	TCLKA
	TCLKC	TCLKB	TCLKB	$\phi/4096$	TCLKC	TCLKC
TCLKD		TCLKC	TCLKA		TCLKD	
General registers	TGR0A	TGR1A	TGR2A	TGR3A	TGR4A	TGR5A
	TGR0B	TGR1B	TGR2B	TGR3B	TGR4B	TGR5B
General registers/ buffer registers	TGR0C	—	—	TGR3C	—	—
	TGR0D			TGR3D		
I/O pins	TIOCA0	TIOCA1	TIOCA2	TIOCA3	TIOCA4	TIOCA5
	TIOCB0	TIOCB1	TIOCB2	TIOCB3	TIOCB4	TIOCB5
	TIOCC0			TIOCC3		
	TIOCD0			TIOCD3		
Counter clear function	TGR compare match or input capture	TGR compare match or input capture	TGR compare match or input capture	TGR compare match or input capture	TGR compare match or input capture	TGR compare match or input capture
Compare match output	0 output	<input type="radio"/>	<input type="radio"/>	<input type="radio"/>	<input type="radio"/>	<input type="radio"/>
	1 output	<input type="radio"/>	<input type="radio"/>	<input type="radio"/>	<input type="radio"/>	<input type="radio"/>
	Toggle output	<input type="radio"/>	<input type="radio"/>	<input type="radio"/>	<input type="radio"/>	<input type="radio"/>
Input capture function	<input type="radio"/>	<input type="radio"/>	<input type="radio"/>	<input type="radio"/>	<input type="radio"/>	<input type="radio"/>
Synchronous operation	<input type="radio"/>	<input type="radio"/>	<input type="radio"/>	<input type="radio"/>	<input type="radio"/>	<input type="radio"/>
PWM mode	<input type="radio"/>	<input type="radio"/>	<input type="radio"/>	<input type="radio"/>	<input type="radio"/>	<input type="radio"/>
Phase counting mode	—	<input type="radio"/>	<input type="radio"/>	—	<input type="radio"/>	<input type="radio"/>
Buffer operation	<input type="radio"/>	—	—	<input type="radio"/>	—	—

Item	Channel 0	Channel 1	Channel 2	Channel 3	Channel 4	Channel 5
DTC activation	TGR compare match or input capture	TGR compare match or input capture	TGR compare match or input capture	TGR compare match or input capture	TGR compare match or input capture	TGR compare match or input capture
A/D conversion start trigger	TGR0A compare match or input capture	TGR1A compare match or input capture	TGR2A compare match or input capture	TGR3A compare match or input capture	TGR4A compare match or input capture	TGR5A compare match or input capture
Interrupt sources	5 sources <ul style="list-style-type: none"> • Compare match or input capture 0A • Compare match or input capture 0B • Compare match or input capture 0C • Compare match or input capture 0D • Overflow 	4 sources <ul style="list-style-type: none"> • Compare match or input capture 1A • Compare match or input capture 1B • Overflow • Underflow 	4 sources <ul style="list-style-type: none"> • Compare match or input capture 2A • Compare match or input capture 2B • Overflow • Underflow 	5 sources <ul style="list-style-type: none"> • Compare match or input capture 3A • Compare match or input capture 3B • Compare match or input capture 3C • Compare match or input capture 3D • Overflow 	4 sources <ul style="list-style-type: none"> • Compare match or input capture 4A • Compare match or input capture 4B • Overflow • Underflow 	4 sources <ul style="list-style-type: none"> • Compare match or input capture 5A • Compare match or input capture 5B • Overflow • Underflow

Legend:

○ : Possible

— : Not possible

9.1.2 Block Diagram

Figure 9.1 shows a block diagram of the TPU.

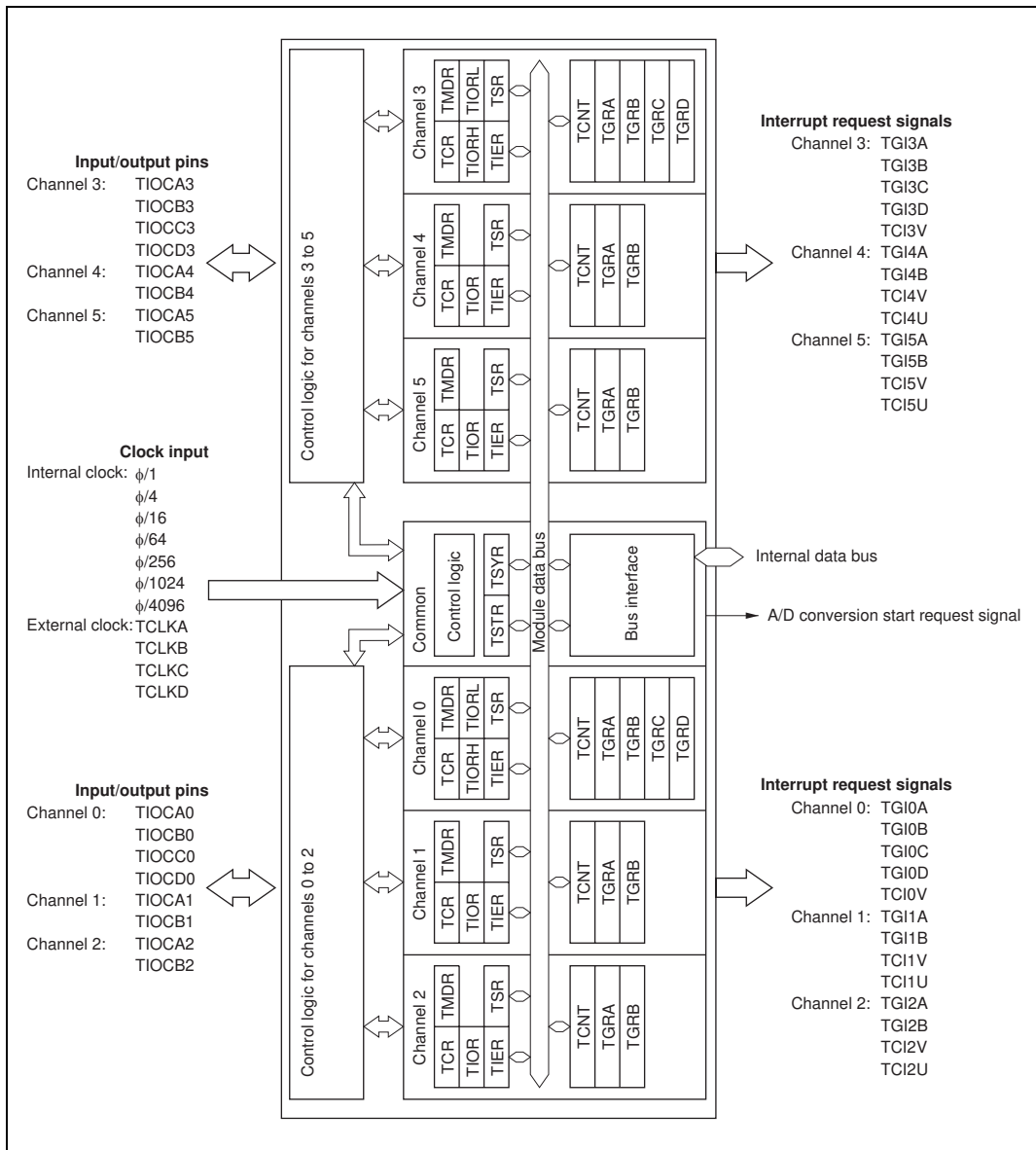

Figure 9.1 Block Diagram of TPU

9.1.3 Pin Configuration

Table 9.2 summarizes the TPU pins.

Table 9.2 TPU Pins

Channel	Name	Symbol	I/O	Function
All	Clock input A	TCLKA	Input	External clock A input pin (Channel 1 and 5 phase counting mode A phase input)
	Clock input B	TCLKB	Input	External clock B input pin (Channel 1 and 5 phase counting mode B phase input)
	Clock input C	TCLKC	Input	External clock C input pin (Channel 2 and 4 phase counting mode A phase input)
	Clock input D	TCLKD	Input	External clock D input pin (Channel 2 and 4 phase counting mode B phase input)
0	Input capture/out compare match A0	TIOCA0	I/O	TGR0A input capture input/output compare output/PWM output pin
	Input capture/out compare match B0	TIOCB0	I/O	TGR0B input capture input/output compare output/PWM output pin
	Input capture/out compare match C0	TIOCC0	I/O	TGR0C input capture input/output compare output/PWM output pin
	Input capture/out compare match D0	TIOCD0	I/O	TGR0D input capture input/output compare output/PWM output pin
1	Input capture/out compare match A1	TIOCA1	I/O	TGR1A input capture input/output compare output/PWM output pin
	Input capture/out compare match B1	TIOCB1	I/O	TGR1B input capture input/output compare output/PWM output pin
2	Input capture/out compare match A2	TIOCA2	I/O	TGR2A input capture input/output compare output/PWM output pin
	Input capture/out compare match B2	TIOCB2	I/O	TGR2B input capture input/output compare output/PWM output pin

Channel	Name	Symbol	I/O	Function
3	Input capture/out compare match A3	TIOCA3	I/O	TGR3A input capture input/output compare output/PWM output pin
	Input capture/out compare match B3	TIOCB3	I/O	TGR3B input capture input/output compare output/PWM output pin
	Input capture/out compare match C3	TIOCC3	I/O	TGR3C input capture input/output compare output/PWM output pin
	Input capture/out compare match D3	TIOCD3	I/O	TGR3D input capture input/output compare output/PWM output pin
4	Input capture/out compare match A4	TIOCA4	I/O	TGR4A input capture input/output compare output/PWM output pin
	Input capture/out compare match B4	TIOCB4	I/O	TGR4B input capture input/output compare output/PWM output pin
5	Input capture/out compare match A5	TIOCA5	I/O	TGR5A input capture input/output compare output/PWM output pin
	Input capture/out compare match B5	TIOCB5	I/O	TGR5B input capture input/output compare output/PWM output pin

9.1.4 Register Configuration

Table 9.3 summarizes the TPU registers.

Table 9.3 TPU Registers

Channel	Name	Abbreviation	R/W	Initial Value	Address*1
0	Timer control register 0	TCR0	R/W	H'00	H'FFD0
	Timer mode register 0	TMDR0	R/W	H'C0	H'FFD1
	Timer I/O control register 0H	TIOR0H	R/W	H'00	H'FFD2
	Timer I/O control register 0L	TIOR0L	R/W	H'00	H'FFD3
	Timer interrupt enable register 0	TIER0	R/W	H'40	H'FFD4
	Timer status register 0	TSR0	R/(W)*2	H'C0	H'FFD5
	Timer counter 0	TCNT0	R/W	H'0000	H'FFD6
	Timer general register 0A	TGR0A	R/W	H'FFFF	H'FFD8
	Timer general register 0B	TGR0B	R/W	H'FFFF	H'FFDA
	Timer general register 0C	TGR0C	R/W	H'FFFF	H'FFDC
	Timer general register 0D	TGR0D	R/W	H'FFFF	H'FFDE
1	Timer control register 1	TCR1	R/W	H'00	H'FFE0
	Timer mode register 1	TMDR1	R/W	H'C0	H'FFE1
	Timer I/O control register 1	TIOR1	R/W	H'00	H'FFE2
	Timer interrupt enable register 1	TIER1	R/W	H'40	H'FFE4
	Timer status register 1	TSR1	R/(W)*2	H'C0	H'FFE5
	Timer counter 1	TCNT1	R/W	H'0000	H'FFE6
	Timer general register 1A	TGR1A	R/W	H'FFFF	H'FFE8
	Timer general register 1B	TGR1B	R/W	H'FFFF	H'FFEA
2	Timer control register 2	TCR2	R/W	H'00	H'FFF0
	Timer mode register 2	TMDR2	R/W	H'C0	H'FFF1
	Timer I/O control register 2	TIOR2	R/W	H'00	H'FFF2
	Timer interrupt enable register 2	TIER2	R/W	H'40	H'FFF4
	Timer status register 2	TSR2	R/(W)*2	H'C0	H'FFF5
	Timer counter 2	TCNT2	R/W	H'0000	H'FFF6
	Timer general register 2A	TGR2A	R/W	H'FFFF	H'FFF8
	Timer general register 2B	TGR2B	R/W	H'FFFF	H'FFFA

Channel	Name	Abbreviation	R/W	Initial Value	Address*1
3	Timer control register 3	TCR3	R/W	H'00	H'FE80
	Timer mode register 3	TMDR3	R/W	H'C0	H'FE81
	Timer I/O control register 3H	TIOR3H	R/W	H'00	H'FE82
	Timer I/O control register 3L	TIOR3L	R/W	H'00	H'FE83
	Timer interrupt enable register 3	TIER3	R/W	H'40	H'FE84
	Timer status register 3	TSR3	R/(W)*2	H'C0	H'FE85
	Timer counter 3	TCNT3	R/W	H'0000	H'FE86
	Timer general register 3A	TGR3A	R/W	H'FFFF	H'FE88
	Timer general register 3B	TGR3B	R/W	H'FFFF	H'FE8A
	Timer general register 3C	TGR3C	R/W	H'FFFF	H'FE8C
	Timer general register 3D	TGR3D	R/W	H'FFFF	H'FE8E
4	Timer control register 4	TCR4	R/W	H'00	H'FE90
	Timer mode register 4	TMDR4	R/W	H'C0	H'FE91
	Timer I/O control register 4	TIOR4	R/W	H'00	H'FE92
	Timer interrupt enable register 4	TIER4	R/W	H'40	H'FE94
	Timer status register 4	TSR4	R/(W)*2	H'C0	H'FE95
	Timer counter 4	TCNT4	R/W	H'0000	H'FE96
	Timer general register 4A	TGR4A	R/W	H'FFFF	H'FE98
	Timer general register 4B	TGR4B	R/W	H'FFFF	H'FE9A
5	Timer control register 5	TCR5	R/W	H'00	H'FEA0
	Timer mode register 5	TMDR5	R/W	H'C0	H'FEA1
	Timer I/O control register 5	TIOR5	R/W	H'00	H'FEA2
	Timer interrupt enable register 5	TIER5	R/W	H'40	H'FEA4
	Timer status register 5	TSR5	R/(W)*2	H'C0	H'FEA5
	Timer counter 5	TCNT5	R/W	H'0000	H'FEA6
	Timer general register 5A	TGR5A	R/W	H'FFFF	H'FEA8
	Timer general register 5B	TGR5B	R/W	H'FFFF	H'FEAA
All	Timer start register	TSTR	R/W	H'00	H'FFC0
	Timer synchro register	TSYR	R/W	H'00	H'FFC1
	Module stop control register	MSTPCR	R/W	H'3FFF	H'FF3C

- Notes: 1. Lower 16 bits of the address.
 2. Can only be written with 0 for flag clearing.

9.2 Register Descriptions

9.2.1 Timer Control Registers (TCR)

Channel 0: TCR0

Channel 3: TCR3

Bit	:	7	6	5	4	3	2	1	0
		CCLR2	CCLR1	CCLR0	CKEG1	CKEG0	TPSC2	TPSC1	TPSC0
Initial value :		0	0	0	0	0	0	0	0
R/W	:	R/W	R/W	R/W	R/W	R/W	R/W	R/W	R/W

Channel 1: TCR1

Channel 2: TCR2

Channel 4: TCR4

Channel 5: TCR5

Bit	:	7	6	5	4	3	2	1	0
		—	CCLR1	CCLR0	CKEG1	CKEG0	TPSC2	TPSC1	TPSC0
Initial value :		0	0	0	0	0	0	0	0
R/W	:	—	R/W	R/W	R/W	R/W	R/W	R/W	R/W

The TCR registers are 8-bit registers that control the TCNT channels. The TPU has six TCR registers, one for each of channels 0 to 5. The TCR registers are initialized to H'00 by a reset and in hardware standby mode.

TCR register settings should be made only when TCNT operation is stopped.

Bits 7 to 5—Counter Clear 2 to 0 (CCLR2 to CCLR0): These bits select the TCNT counter clearing source.

Channel	Bit 7 CCLR2	Bit 6 CCLR1	Bit 5 CCLR0	Description	
0, 3	0	0	0	TCNT clearing disabled (Initial value)	
			1	TCNT cleared by TGRA compare match/input capture	
			1	0	TCNT cleared by TGRB compare match/input capture
				1	TCNT cleared by counter clearing for another channel performing synchronous clearing/synchronous operation *1
	1	0	0	TCNT clearing disabled	
			1	TCNT cleared by TGRC compare match/input capture *2	
			1	0	TCNT cleared by TGRD compare match/input capture *2
				1	TCNT cleared by counter clearing for another channel performing synchronous clearing/synchronous operation *1

Channel	Bit 7 Reserved*3	Bit 6 CCLR1	Bit 5 CCLR0	Description	
1, 2, 4, 5	0	0	0	TCNT clearing disabled (Initial value)	
			1	TCNT cleared by TGRA compare match/input capture	
			1	0	TCNT cleared by TGRB compare match/input capture
				1	TCNT cleared by counter clearing for another channel performing synchronous clearing/synchronous operation *1

- Notes:
1. Synchronous operation setting is performed by setting the SYNC bit in TSYR to 1.
 2. When TGRC or TGRD is used as a buffer register, TCNT is not cleared because the buffer register setting has priority, and compare match/input capture does not occur.
 3. Bit 7 is reserved in channels 1, 2, 4, and 5. It is always read as 0 and cannot be modified.

Bits 4 and 3—Clock Edge 1 and 0 (CKEG1, CKEG0): These bits select the input clock edge. When the input clock is counted using both edges, the input clock period is halved (e.g. $\phi/4$ both edges = $\phi/2$ rising edge). If phase counting mode is used on channels 1, 2, 4, and 5, this setting is ignored and the phase counting mode setting has priority.

Bit 4 CKEG1	Bit 3 CKEG0	Description	
0	0	Count at rising edge	(Initial value)
	1	Count at falling edge	
1	—	Count at both edges	

Note: Internal clock edge selection is valid when the input clock is $\phi/4$ or slower. This setting is ignored if the input clock is $\phi/1$, or when overflow/underflow of another channel is selected.

Bits 2 to 0—Time Prescaler 2 to 0 (TPSC2 to TPSC0): These bits select the TCNT counter clock. The clock source can be selected independently for each channel. Table 9.4 shows the clock sources that can be set for each channel.

Table 9.4 TPU Clock Sources

Channel	Internal Clock							External Clock				Overflow/ Underflow on Another Channel
	$\phi/1$	$\phi/4$	$\phi/16$	$\phi/64$	$\phi/256$	$\phi/1024$	$\phi/4096$	TCLKA	TCLKB	TCLKC	TCLKD	
0	○	○	○	○				○	○	○	○	
1	○	○	○	○	○			○	○			○
2	○	○	○	○		○		○	○	○		
3	○	○	○	○	○	○	○	○				
4	○	○	○	○		○		○		○		○
5	○	○	○	○	○			○		○	○	

Legend:

○: Setting

Blank: No setting

Channel	Bit 2 TPSC2	Bit 1 TPSC1	Bit 0 TPSC0	Description
0	0	0	0	Internal clock: counts on $\phi/1$ (Initial value)
			1	Internal clock: counts on $\phi/4$
		1	0	Internal clock: counts on $\phi/16$
			1	Internal clock: counts on $\phi/64$
	1	0	0	External clock: counts on TCLKA pin input
			1	External clock: counts on TCLKB pin input
		1	0	External clock: counts on TCLKC pin input
			1	External clock: counts on TCLKD pin input

Channel	Bit 2 TPSC2	Bit 1 TPSC1	Bit 0 TPSC0	Description
1	0	0	0	Internal clock: counts on $\phi/1$ (Initial value)
			1	Internal clock: counts on $\phi/4$
		1	0	Internal clock: counts on $\phi/16$
			1	Internal clock: counts on $\phi/64$
	1	0	0	External clock: counts on TCLKA pin input
			1	External clock: counts on TCLKB pin input
		1	0	Internal clock: counts on $\phi/256$
			1	Counts on TCNT2 overflow/underflow

Note: This setting is ignored when channel 1 is in phase counting mode.

Channel	Bit 2 TPSC2	Bit 1 TPSC1	Bit 0 TPSC0	Description
2	0	0	0	Internal clock: counts on $\phi/1$ (Initial value)
			1	Internal clock: counts on $\phi/4$
		1	0	Internal clock: counts on $\phi/16$
			1	Internal clock: counts on $\phi/64$
	1	0	0	External clock: counts on TCLKA pin input
			1	External clock: counts on TCLKB pin input
		1	0	External clock: counts on TCLKC pin input
			1	Internal clock: counts on $\phi/1024$

Note: This setting is ignored when channel 2 is in phase counting mode.

Channel	Bit 2 TPSC2	Bit 1 TPSC1	Bit 0 TPSC0	Description
3	0	0	0	Internal clock: counts on $\phi/1$ (Initial value)
			1	Internal clock: counts on $\phi/4$
		1	0	Internal clock: counts on $\phi/16$
			1	Internal clock: counts on $\phi/64$
	1	0	0	External clock: counts on TCLKA pin input
			1	Internal clock: counts on $\phi/1024$
		1	0	Internal clock: counts on $\phi/256$
			1	Internal clock: counts on $\phi/4096$

Channel	Bit 2 TPSC2	Bit 1 TPSC1	Bit 0 TPSC0	Description
4	0	0	0	Internal clock: counts on $\phi/1$ (Initial value)
			1	Internal clock: counts on $\phi/4$
		1	0	Internal clock: counts on $\phi/16$
			1	Internal clock: counts on $\phi/64$
	1	0	0	External clock: counts on TCLKA pin input
			1	External clock: counts on TCLKC pin input
		1	0	Internal clock: counts on $\phi/1024$
			1	Counts on TCNT5 overflow/underflow

Note: This setting is ignored when channel 4 is in phase counting mode.

Channel	Bit 2 TPSC2	Bit 1 TPSC1	Bit 0 TPSC0	Description
5	0	0	0	Internal clock: counts on $\phi/1$ (Initial value)
			1	Internal clock: counts on $\phi/4$
		1	0	Internal clock: counts on $\phi/16$
			1	Internal clock: counts on $\phi/64$
	1	0	0	External clock: counts on TCLKA pin input
			1	External clock: counts on TCLKC pin input
		1	0	Internal clock: counts on $\phi/256$
			1	External clock: counts on TCLKD pin input

Note: This setting is ignored when channel 5 is in phase counting mode.

9.2.2 Timer Mode Registers (TMDR)

Channel 0: TMDR0

Channel 3: TMDR3

Bit	:	7	6	5	4	3	2	1	0
		—	—	BFB	BFA	MD3	MD2	MD1	MD0
Initial value :		1	1	0	0	0	0	0	0
R/W	:	—	—	R/W	R/W	R/W	R/W	R/W	R/W

Channel 1: TMDR1

Channel 2: TMDR2

Channel 4: TMDR4

Channel 5: TMDR5

Bit	:	7	6	5	4	3	2	1	0
		—	—	—	—	MD3	MD2	MD1	MD0
Initial value :		1	1	0	0	0	0	0	0
R/W	:	—	—	—	—	R/W	R/W	R/W	R/W

The TMDR registers are 8-bit readable/writable registers that are used to set the operating mode for each channel. The TPU has six TMDR registers, one for each channel. The TMDR registers are initialized to H'C0 by a reset and in hardware standby mode.

TMDR register settings should be made only when TCNT operation is stopped.

Bits 7 and 6—Reserved: These bits cannot be modified and are always read as 1.

Bit 5—Buffer Operation B (BFB): Specifies whether TGRB is to operate in the normal way, or TGRB and TGRD are to be used together for buffer operation. When TGRD is used as a buffer register, TGRD input capture/output compare is not generated.

In channels 1, 2, 4, and 5, which have no TGRD, bit 5 is reserved. It is always read as 0 and cannot be modified.

Bit 5

BFB	Description
0	TGRB operates normally (Initial value)
1	TGRB and TGRD used together for buffer operation

Bit 4—Buffer Operation A (BFA): Specifies whether TGRA is to operate in the normal way, or TGRA and TGRC are to be used together for buffer operation. When TGRC is used as a buffer register, TGRC input capture/output compare is not generated.

In channels 1, 2, 4, and 5, which have no TGRC, bit 4 is reserved. It is always read as 0 and cannot be modified.

Bit 4

BFA	Description
0	TGRA operates normally (Initial value)
1	TGRA and TGRC used together for buffer operation

Bits 3 to 0—Modes 3 to 0 (MD3 to MD0): These bits are used to set the timer operating mode.

Bit 3 MD3*1	Bit 2 MD2*2	Bit 1 MD1	Bit 0 MD0	Description	
0	0	0	0	Normal operation (Initial value)	
			1	Reserved	
	1	0	0	PWM mode 1	
			1	PWM mode 2	
	1	0	0	Phase counting mode 1	
			1	Phase counting mode 2	
		1	0	0	Phase counting mode 3
				1	Phase counting mode 4
1	x	x	x	—	

x: Don't care

- Notes: 1. MD3 is a reserved bit. In a write, it should always be written with 0.
 2. Phase counting mode cannot be set for channels 0 and 3. For these channels, 0 should always be written to MD2.

9.2.3 Timer I/O Control Registers (TIOR)

Channel 0: TIOR0H

Channel 1: TIOR1

Channel 2: TIOR2

Channel 3: TIOR3H

Channel 4: TIOR4

Channel 5: TIOR5

Bit	:	7	6	5	4	3	2	1	0
		IOB3	IOB2	IOB1	IOB0	IOA3	IOA2	IOA1	IOA0
Initial value :		0	0	0	0	0	0	0	0
R/W	:	R/W	R/W	R/W	R/W	R/W	R/W	R/W	R/W

Channel 0: TIOR0L

Channel 3: TIOR3L

Bit	:	7	6	5	4	3	2	1	0
		IOD3	IOD2	IOD1	IOD0	IOC3	IOC2	IOC1	IOC0
Initial value :		0	0	0	0	0	0	0	0
R/W	:	R/W	R/W	R/W	R/W	R/W	R/W	R/W	R/W

Note: When TGRC or TGRD is designated for buffer operation, this setting is invalid and the register operates as a buffer register.

The TIOR registers are 8-bit registers that control the TGR registers. The TPU has eight TIOR registers, two each for channels 0 and 3, and one each for channels 1, 2, 4, and 5. The TIOR registers are initialized to H'00 by a reset and in hardware standby mode.

Care is required since TIOR is affected by the TMDR setting. The initial output specified by TIOR is valid when the counter is stopped (the CST bit in TSTR is cleared to 0). Note also that, in PWM mode 2, the output at the point at which the counter is cleared to 0 is specified.

Bits 7 to 4— I/O Control B3 to B0 (IOB3 to IOB0)**I/O Control D3 to D0 (IOD3 to IOD0):**

Bits IOB3 to IOB0 specify the function of TGRB.

Bits IOD3 to IOD0 specify the function of TGRD.

Channel	Bit 7	Bit 6	Bit 5	Bit 4	Description				
	IOB3	IOB2	IOB1	IOB0					
0	0	0	0	0	TGR0B is output compare register	Output disabled	(Initial value)		
				1			Initial output is 0	0 output at compare match	
				0			output	1 output at compare match	
				1				Toggle output at compare match	
	1	0	0	0	TGR0B is input capture register	Capture input source is TIOCB0 pin	Input capture at rising edge		
				1				Initial output is 1	0 output at compare match
				0				output	1 output at compare match
				1					Toggle output at compare match
1	0	0	0	TGR0B is input capture register	Capture input source is channel 1/count clock	Input capture at both edges			
			1						
			×						
			×						
1	×	×	×	TGR0B is input capture register	Capture input source is channel 1/count clock	Input capture at TCNT1 count-up/count-down*			
			×						
			×						
			×						

×: Don't care

Note: * When bits TPSC2 to TPSC0 in TCR1 are set to B'000 and $\phi/1$ is used as the TCNT1 count clock, this setting is invalid and input capture is not generated.

Channel	Bit 7 IOD3	Bit 6 IOD2	Bit 5 IOD1	Bit 4 IOD0	Description			
0	0	0	0	0	TGR0D	Output disabled	(Initial value)	
				1	is output	Initial output is 0	0 output at compare match	
				0	compare	output	1 output at compare match	
				1	register*2	Toggle output at compare match		
	1	0	0	0		Output disabled		
				1		Initial output is 1	0 output at compare match	
				0		output	1 output at compare match	
				1		Toggle output at compare match		
1	0	0	0	TGR0D	Capture input	Input capture at rising edge		
			1	is input	source is	Input capture at falling edge		
			×	capture	TIOCD0 pin	Input capture at both edges		
			×	register*2	Capture input	Input capture at TCNT1		
	1	×	×		source is channel	count-up/count-down*1		
					1/count clock			

×: Don't care

- Notes: 1. When bits TPSC2 to TPSC0 in TCR1 are set to B'000 and $\phi/1$ is used as the TCNT1 count clock, this setting is invalid and input capture is not generated.
2. When the BFB bit in TMDR0 is set to 1 and TGR0D is used as a buffer register, this setting is invalid and input capture/output compare is not generated.

Channel	Bit 7	Bit 6	Bit 5	Bit 4	Description		
	IOB3	IOB2	IOB1	IOB0			
1	0	0	0	0	TGR1B is output compare register	Output disabled	(Initial value)
				1		Initial output is 0 output	0 output at compare match
				1		0	1 output at compare match
				1		Toggle output at compare match	
	1	0	0	0	TGR1B is input capture register	Output disabled	
				1		Initial output is 1 output	0 output at compare match
				1		0	1 output at compare match
				1		Toggle output at compare match	
1	0	0	0	TGR1B is input capture register	Capture input source is TIOCB1 pin	Input capture at rising edge	
			1		×	Input capture at falling edge	
1	0	0	1	TGR0C is input capture register	Capture input source is TGR0C compare match/ input capture	Input capture at both edges	
			1		×	×	Input capture at generation of TGR0C compare match/input capture

×: Don't care

Channel	Bit 7	Bit 6	Bit 5	Bit 4	Description		
	IOB3	IOB2	IOB1	IOB0			
2	0	0	0	0	TGR2B is output compare register	Output disabled	(Initial value)
				1		Initial output is 0 output	0 output at compare match
				1		0	1 output at compare match
				1		Toggle output at compare match	
	1	0	0	0	TGR2B is input capture register	Output disabled	
				1		Initial output is 1 output	0 output at compare match
				1		0	1 output at compare match
				1		Toggle output at compare match	
1	×	0	0	TGR2B is input capture register	Capture input source is TIOCB2 pin	Input capture at rising edge	
			1		×	×	Input capture at falling edge
1	×	0	1	TGR2B is input capture register	Capture input source is TIOCB2 pin	Input capture at both edges	
			1		×	×	Input capture at both edges

×: Don't care

Channel	Bit 7	Bit 6	Bit 5	Bit 4	Description		
	IOB3	IOB2	IOB1	IOB0			
3	0	0	0	0	TGR3B is output compare register	Output disabled	(Initial value)
				1		Initial output is 0 output	0 output at compare match
				1		0 output at compare match	1 output at compare match
	1	0	0	0	TGR3B is input capture register	Output disabled	
				1		Initial output is 1 output	0 output at compare match
				1		0 output at compare match	1 output at compare match
1	0	0	0	TGR3B is input capture register	Capture input source is TIOCB3 pin	Input capture at rising edge	
			1		×	Input capture at falling edge	
			1		×	Input capture at both edges	
	1	×	×		Capture input source is channel 4/count clock	Input capture at TCNT4 count-up/count-down*	

×: Don't care

Note: * When bits TPSC2 to TPSC0 in TCR4 are set to B'000 and $\phi/1$ is used as the TCNT4 count clock, this setting is invalid and input capture is not generated.

Channel	Bit 7	Bit 6	Bit 5	Bit 4	Description		
	IOD3	IOD2	IOD1	IOD0			
3	0	0	0	0	TGR3D	Output disabled	(Initial value)
				1	is output compare register*2	Initial output is 0 output	0 output at compare match
				1	0	1 output at compare match	
				1		Toggle output at compare match	
	1	0	0	0		Output disabled	
				1		Initial output is 1 output	0 output at compare match
				1	0	1 output at compare match	
				1		Toggle output at compare match	
1	0	0	0	TGR3D	Capture input source is	Input capture at rising edge	
			1	is input capture register*2	TIOCD3 pin	Input capture at falling edge	
			1	×		Input capture at both edges	
			1	×	×	Capture input source is channel 4/count clock	Input capture at TCNT4 count-up/count-down*1

×: Don't care

- Notes: 1. When bits TPSC2 to TPSC0 in TCR4 are set to B'000 and $\phi/1$ is used as the TCNT4 count clock, this setting is invalid and input capture is not generated.
2. When the BFB bit in TMDR3 is set to 1 and TGR3D is used as a buffer register, this setting is invalid and input capture/output compare is not generated.

Channel	Bit 7	Bit 6	Bit 5	Bit 4	Description					
	IOB3	IOB2	IOB1	IOB0						
4	0	0	0	0	TGR4B is output compare register	Output disabled	(Initial value)			
				1			Initial output is 0	0 output at compare match		
				1			0	1 output at compare match		
							1	Toggle output at compare match		
				1			0	0	Output disabled	
								1	Initial output is 1	0 output at compare match
	1	output	1 output at compare match							
	1	0	0	0	TGR4B is input capture register	Capture input source is TIOCB4 pin	Input capture at rising edge			
				1			Input capture at falling edge			
				1			×	Input capture at both edges		
				1			×	×	Capture input source is TGR3C compare match/ input capture	Input capture at generation of TGR3C compare match/ input capture

×: Don't care

Channel	Bit 7	Bit 6	Bit 5	Bit 4	Description				
	IOB3	IOB2	IOB1	IOB0					
5	0	0	0	0	TGR5B is output compare register	Output disabled	(Initial value)		
				1			Initial output is 0	0 output at compare match	
				1			0	1 output at compare match	
							1	Toggle output at compare match	
				1			0	0	Output disabled
								1	Initial output is 1
	1	output	1 output at compare match						
	1	×	0	0	TGR5B is input capture register	Capture input source is TIOCB5 pin	Input capture at rising edge		
				1			Input capture at falling edge		
				1			×	Input capture at both edges	

×: Don't care

Bits 3 to 0— I/O Control A3 to A0 (IOA3 to IOA0)**I/O Control C3 to C0 (IOC3 to IOC0):**

IOA3 to IOA0 specify the function of TGRA.

IOC3 to IOC0 specify the function of TGRC.

Channel	Bit 3	Bit 2	Bit 1	Bit 0	Description	
	IOA3	IOA2	IOA1	IOA0		
0	0	0	0	0	TGR0A	Output disabled (Initial value)
				1	is output	Initial output is 0
				0	compare	0 output at compare match`
				1	register	1 output at compare match
				0		Toggle output at compare match
				1		
	1	0	0	0		Output disabled
				1		Initial output is 1
				0		output
				1		0 output at compare match
				0		1 output at compare match
				1		Toggle output at compare match
1	0	0	0	TGR0A	Capture input	
			1	is input	Input capture at rising edge	
			0	capture	Input capture at falling edge	
			1	register	Input capture at both edges	
			×			
			×			
1	1	×	×		Capture input	
					source is channel	Input capture at TCNT1
					1/count clock	count-up/count-down

×: Don't care

Channel	Bit 3	Bit 2	Bit 1	Bit 0	Description		
	IOC3	IOC2	IOC1	IOC0			
0	0	0	0	0	TGR0C is output compare register*1	Output disabled	(Initial value)
				1		Initial output is 0 output	0 output at compare match
				1		1 output at compare match	
				1		Toggle output at compare match	
	1	0	0	0	TGR0C is input capture register*	Output disabled	
				1		Initial output is 1 output	0 output at compare match
				1		1 output at compare match	
				1		Toggle output at compare match	
1	0	0	0	TGR0C is input capture register*	Capture input source is TIOCC0 pin	Input capture at rising edge	
			1		Input capture at falling edge		
			1		Input capture at both edges		
			1		Input capture at TCNT1 count-up/count-down 1/count clock		

x: Don't care

Note: * When the BFA bit in TMDR0 is set to 1 and TGR0C is used as a buffer register, this setting is invalid and input capture/output compare is not generated.

Channel	Bit 3 IOA3	Bit 2 IOA2	Bit 1 IOA1	Bit 0 IOA0	Description			
1	0	0	0	0	TGR1A is output compare register	Output disabled	(Initial value)	
				1			Initial output is 0 output	0 output at compare match
				0			1 output at compare match	
				1			Toggle output at compare match	
	1	0	0	0	TGR1A is input capture register	Output disabled		
				1			Initial output is 1 output	0 output at compare match
				0			1 output at compare match	
				1			Toggle output at compare match	
1	0	0	0	TGR1A is input capture register	Capture input source is TIOCA1 pin	Input capture at rising edge		
			1			Input capture at falling edge		
			×			Input capture at both edges		
			×			Capture input source is TGR0A compare match/ input capture	Input capture at generation of channel 0/TGR0A compare match/input capture	

×: Don't care

Channel	Bit 3 IOA3	Bit 2 IOA2	Bit 1 IOA1	Bit 0 IOA0	Description			
2	0	0	0	0	TGR2A is output compare register	Output disabled	(Initial value)	
				1			Initial output is 0 output	0 output at compare match
				0			1 output at compare match	
				1			Toggle output at compare match	
	1	0	0	0	TGR2A is input capture register	Output disabled		
				1			Initial output is 1 output	0 output at compare match
				0			1 output at compare match	
				1			Toggle output at compare match	
1	×	0	0	TGR2A is input capture register	Capture input source is TIOCA2 pin	Input capture at rising edge		
			1			Input capture at falling edge		
			×			Input capture at both edges		
			×			Capture input source is TGR0A compare match/ input capture	Input capture at generation of channel 0/TGR0A compare match/input capture	

×: Don't care

Channel	Bit 3 IOA3	Bit 2 IOA2	Bit 1 IOA1	Bit 0 IOA0	Description		
3	0	0	0	0	TGR3A is output compare register	Output disabled (Initial value)	
				1		Initial output is 0	0 output at compare match
				1		1 output at compare match	
				1		Toggle output at compare match	
	1	0	0	0	TGR3A is input capture register	Output disabled	
				1		Initial output is 1	0 output at compare match
				1		1 output at compare match	
				1		Toggle output at compare match	
1	0	0	0	TGR3A is input capture register	Capture input source is TIOCA3 pin	Input capture at rising edge	
			1		Input capture at falling edge		
			1		Input capture at both edges		
			1		Capture input source is channel 4/count clock	Input capture at TCNT4 count-up/count-down	

x: Don't care

Channel	Bit 3	Bit 2	Bit 1	Bit 0	Description			
	IOC3	IOC2	IOC1	IOC0				
3	0	0	0	0	TGR3C is output compare register* ¹	Output disabled	(Initial value)	
				1			Initial output is 0	0 output at compare match
				0			1 output at compare match	
				1			Toggle output at compare match	
	1	0	0	0	TGR3C is input capture register*	Capture input source is TIOCC3 pin	Input capture at rising edge	0 output at compare match
				1				1 output at compare match
				0				1 output at compare match
				1				Toggle output at compare match
1	0	0	0	TGR3C is input capture register*	Capture input source is channel 4/count clock	Input capture at TCNT4 count-up/count-down	Input capture at both edges	
			1				Input capture at falling edge	
			×				Input capture at both edges	
			×				Input capture at TCNT4 count-up/count-down	

×: Don't care

Note: * When the BFA bit in TMDR3 is set to 1 and TGR3C is used as a buffer register, this setting is invalid and input capture/output compare is not generated.

Channel	Bit 3 IOA3	Bit 2 IOA2	Bit 1 IOA1	Bit 0 IOA0	Description				
4	0	0	0	0	TGR4A	Output disabled	(Initial value)		
				1	is output compare register	Initial output is 0 output	0 output at compare match		
				1	0	1 output at compare match			
				1	1	Toggle output at compare match			
				1	0	0	Output disabled		
				1	1	Initial output is 1 output	0 output at compare match		
	1	0	0	0	TGR4A	Capture input source is TIOCA4 pin	Input capture at rising edge		
				1	is input capture register	Input capture at falling edge			
				1	×	Input capture at both edges			
				1	×	×	Capture input source is TGR3A compare match/ input capture	Input capture at generation of TGR3A compare match/ input capture	
				1	×	×			
				1	×	×			

×: Don't care

Channel	Bit 3 IOA3	Bit 2 IOA2	Bit 1 IOA1	Bit 0 IOA0	Description				
5	0	0	0	0	TGR5A	Output disabled	(Initial value)		
				1	is output compare register	Initial output is 0 output	0 output at compare match		
				1	0	1 output at compare match			
				1	1	Toggle output at compare match			
				1	0	0	Output disabled		
				1	1	Initial output is 1 output	0 output at compare match		
	1	×	0	0	TGR5A	Capture input source is TIOCA5 pin	Input capture at rising edge		
				1	is input capture register	Input capture at falling edge			
				1	×	Input capture at both edges			
				1	×	×			
				1	×	×			
				1	×	×			

×: Don't care

9.2.4 Timer Interrupt Enable Registers (TIER)

Channel 0: TIER0

Channel 3: TIER3

Bit	:	7	6	5	4	3	2	1	0
		TTGE	—	—	TCIEV	TGIED	TGIEC	TGIEB	TGIEA
Initial value :		0	1	0	0	0	0	0	0
R/W	:	R/W	—	—	R/W	R/W	R/W	R/W	R/W

Channel 1: TIER1

Channel 2: TIER2

Channel 4: TIER4

Channel 5: TIER5

Bit	:	7	6	5	4	3	2	1	0
		TTGE	—	TCIEU	TCIEV	—	—	TGIEB	TGIEA
Initial value :		0	1	0	0	0	0	0	0
R/W	:	R/W	—	R/W	R/W	—	—	R/W	R/W

The TIER registers are 8-bit registers that control enabling or disabling of interrupt requests for each channel. The TPU has six TIER registers, one for each channel. The TIER registers are initialized to H'40 by a reset and in hardware standby mode.

Bit 7—A/D Conversion Start Request Enable (TTGE): Enables or disables generation of A/D conversion start requests by TGRA input capture/compare match.

Bit 7

TTGE	Description
0	A/D conversion start request generation disabled (Initial value)
1	A/D conversion start request generation enabled

Bit 6—Reserved: This bit cannot be modified and is always read as 1.

Bit 5—Underflow Interrupt Enable (TCIEU): Enables or disables interrupt requests (TCIU) by the TCFU bit when the TCFU bit in TSR is set to 1 in channels 1 and 2.

In channels 0 and 3, bit 5 is reserved. It is always read as 0 and cannot be modified.

Bit 5

TCIEU	Description
0	Interrupt requests (TCIU) by TCFU disabled (Initial value)
1	Interrupt requests (TCIU) by TCFU enabled

Bit 4—Overflow Interrupt Enable (TCIEV): Enables or disables interrupt requests (TCIV) by the TCFV bit when the TCFV bit in TSR is set to 1.

Bit 4

TCIEV	Description
0	Interrupt requests (TCIV) by TCFV disabled (Initial value)
1	Interrupt requests (TCIV) by TCFV enabled

Bit 3—TGR Interrupt Enable D (TGIED): Enables or disables interrupt requests (TGID) by the TGFD bit when the TGFD bit in TSR is set to 1 in channels 0 and 3.

In channels 1, 2, 4, and 5, bit 3 is reserved. It is always read as 0 and cannot be modified.

Bit 3

TGIED	Description
0	Interrupt requests (TGID) by TGFD disabled (Initial value)
1	Interrupt requests (TGID) by TGFD enabled

Bit 2—TGR Interrupt Enable C (TGIEC): Enables or disables interrupt requests (TGIC) by the TGFC bit when the TGFC bit in TSR is set to 1 in channels 0 and 3.

In channels 1, 2, 4, and 5, bit 2 is reserved. It is always read as 0 and cannot be modified.

Bit 2

TGIEC	Description
0	Interrupt requests (TGIC) by TGFC disabled (Initial value)
1	Interrupt requests (TGIC) by TGFC enabled

Bit 1—TGR Interrupt Enable B (TGIEB): Enables or disables interrupt requests (TGIB) by the TGFB bit when the TGFB bit in TSR is set to 1.

Bit 1

TGIEB	Description	
0	Interrupt requests (TGIB) by TGFB disabled	(Initial value)
1	Interrupt requests (TGIB) by TGFB enabled	

Bit 0—TGR Interrupt Enable A (TGIEA): Enables or disables interrupt requests (TGIA) by the TGFA bit when the TGFA bit in TSR is set to 1.

Bit 0

TGIEA	Description	
0	Interrupt requests (TGIA) by TGFA disabled	(Initial value)
1	Interrupt requests (TGIA) by TGFA enabled	

9.2.5 Timer Status Registers (TSR)

Channel 0: TSR0

Channel 3: TSR3

Bit	:	7	6	5	4	3	2	1	0
		—	—	—	TCFV	TGFD	TGFC	TGFB	TGFA
Initial value	:	1	1	0	0	0	0	0	0
R/W	:	—	—	—	R/(W)*	R/(W)*	R/(W)*	R/(W)*	R/(W)*

Note: * Only 0 can be written, to clear the flag.

Channel 1: TSR1

Channel 2: TSR2

Channel 4: TSR4

Channel 5: TSR5

Bit	:	7	6	5	4	3	2	1	0
		TCFD	—	TCFU	TCFV	—	—	TGFB	TGFA
Initial value	:	1	1	0	0	0	0	0	0
R/W	:	R	—	R/(W)*	R/(W)*	—	—	R/(W)*	R/(W)*

Note: * Only 0 can be written, to clear the flag.

The TSR registers are 8-bit registers that indicate the status of each channel. The TPU has six TSR registers, one for each channel. The TSR registers are initialized to H'00 by a reset and in hardware standby mode.

Bit 7—Count Direction Flag (TCFD): Status flag that shows the direction in which TCNT counts in channels 1, 2, 4, and 5.

In channels 0 and 3, bit 7 is reserved. It is always read as 1 and cannot be modified.

Bit 7

TCFD	Description
0	TCNT counts down
1	TCNT counts up (Initial value)

Bit 6—Reserved: This bit cannot be modified and is always read as 1.

Bit 5—Underflow Flag (TCFU): Status flag that indicates that TCNT underflow has occurred when channels 1, 2, 4, and 5 are set to phase counting mode.

In channels 0 and 3, bit 5 is reserved. It is always read as 0 and cannot be modified.

Bit 5 TCFU	Description	
0	[Clearing condition] When 0 is written to TCFU after reading TCFU = 1	(Initial value)
1	[Setting condition] When the TCNT value underflows (changes from H'0000 to H'FFFF)	

Bit 4—Overflow Flag (TCFV): Status flag that indicates that TCNT overflow has occurred.

Bit 4 TCFV	Description	
0	[Clearing condition] When 0 is written to TCFV after reading TCFV = 1	(Initial value)
1	[Setting condition] When the TCNT value overflows (changes from H'FFFF to H'0000)	

Bit 3—Input Capture/Output Compare Flag D (TGFD): Status flag that indicates the occurrence of TGRD input capture or compare match in channels 0 and 3.

In channels 1, 2, 4, and 5, bit 3 is reserved. It is always read as 0 and cannot be modified.

Bit 3 TGFD	Description	
0	[Clearing conditions] <ul style="list-style-type: none"> • When DTC is activated by TGID interrupt while DISEL bit of MRB in DTC is 0 • When 0 is written to TGFD after reading TGFD = 1 	(Initial value)
1	[Setting conditions] <ul style="list-style-type: none"> • When TCNT = TGRD while TGRD is functioning as output compare register • When TCNT value is transferred to TGRD by input capture signal while TGRD is functioning as input capture register 	

Bit 2—Input Capture/Output Compare Flag C (TGFC): Status flag that indicates the occurrence of TGRC input capture or compare match in channels 0 and 3.

In channels 1, 2, 4, and 5, bit 2 is reserved. It is always read as 0 and cannot be modified.

Bit 2

TGFC	Description
0	[Clearing conditions] (Initial value) <ul style="list-style-type: none"> • When DTC is activated by TGIC interrupt while DIESEL bit of MRB in DTC is 0 • When 0 is written to TGFC after reading TGFC = 1
1	[Setting conditions] <ul style="list-style-type: none"> • When TCNT = TGRC while TGRC is functioning as output compare register • When TCNT value is transferred to TGRC by input capture signal while TGRC is functioning as input capture register

Bit 1—Input Capture/Output Compare Flag B (TGFB): Status flag that indicates the occurrence of TGRB input capture or compare match.

Bit 1

TGFB	Description
0	[Clearing conditions] (Initial value) <ul style="list-style-type: none"> • When DTC is activated by TGIB interrupt while DIESEL bit of MRB in DTC is 0 • When 0 is written to TGFB after reading TGFB = 1
1	[Setting conditions] <ul style="list-style-type: none"> • When TCNT = TGRB while TGRB is functioning as output compare register • When TCNT value is transferred to TGRB by input capture signal while TGRB is functioning as input capture register

Bit 0—Input Capture/Output Compare Flag A (TGFA): Status flag that indicates the occurrence of TGRA input capture or compare match.

Bit 0 TGFA	Description
0	[Clearing conditions] (Initial value) <ul style="list-style-type: none"> When DTC is activated by TGIA interrupt while DIESEL bit of MRB in DTC is 0 When 0 is written to TGFA after reading TGFA = 1
1	[Setting conditions] <ul style="list-style-type: none"> When TCNT = TGRA while TGRA is functioning as output compare register When TCNT value is transferred to TGRA by input capture signal while TGRA is functioning as input capture register

9.2.6 Timer Counters (TCNT)

Channel 0: TCNT0 (up-counter)

Channel 1: TCNT1 (up/down-counter*)

Channel 2: TCNT2 (up/down-counter*)

Channel 3: TCNT3 (up-counter)

Channel 4: TCNT4 (up/down-counter*)

Channel 5: TCNT5 (up/down-counter*)

Bit	:	15	14	13	12	11	10	9	8	7	6	5	4	3	2	1	0
Initial value :		0	0	0	0	0	0	0	0	0	0	0	0	0	0	0	0
R/W	:	R/W	R/W	R/W	R/W	R/W	R/W	R/W	R/W	R/W	R/W	R/W	R/W	R/W	R/W	R/W	R/W

Note: * These counters can be used as up/down-counters only in phase counting mode or when counting overflow/underflow on another channel. In other cases they function as up-counters.

The TCNT registers are 16-bit counters. The TPU has six TCNT counters, one for each channel.

The TCNT counters are initialized to H'0000 by a reset and in hardware standby mode.

The TCNT counters cannot be accessed in 8-bit units; they must always be accessed as a 16-bit unit.

9.2.7 Timer General Registers (TGR)

Bit	:	15	14	13	12	11	10	9	8	7	6	5	4	3	2	1	0
Initial value	:	1	1	1	1	1	1	1	1	1	1	1	1	1	1	1	1
R/W	:	R/W	R/W	R/W	R/W	R/W	R/W	R/W	R/W	R/W	R/W	R/W	R/W	R/W	R/W	R/W	R/W

The TGR registers are 16-bit registers with a dual function as output compare and input capture registers. The TPU has 16 TGR registers, four each for channels 0 and 3 and two each for channels 1, 2, 4, and 5. TGRC and TGRD for channels 0 and 3 can also be designated for operation as buffer registers*. The TGR registers are initialized to H'FFFF by a reset and in hardware standby mode.

The TGR registers cannot be accessed in 8-bit units; they must always be accessed as a 16-bit unit.

Note: * TGR buffer register combinations are TGRA—TGRC and TGRB—TGRD.

9.2.8 Timer Start Register (TSTR)

Bit	:	7	6	5	4	3	2	1	0
		—	—	CST5	CST4	CST3	CST2	CST1	CST0
Initial value	:	0	0	0	0	0	0	0	0
R/W	:	—	—	R/W	R/W	R/W	R/W	R/W	R/W

TSTR is an 8-bit readable/writable register that selects operation/stoppage for channels 0 to 5. TSTR is initialized to H'00 by a reset, and in hardware standby mode. When setting the operating mode in TMDR or setting the count clock in TCR, first stop the TCNT counter.

Bits 7 and 6—Reserved: Must always be written with 0.

Bits 5 to 0—Counter Start 5 to 0 (CST5 to CST0): These bits select operation or stoppage for TCNT.

Bit n CSTn	Description
0	TCNTn count operation is stopped (Initial value)
1	TCNTn performs count operation

n = 5 to 0

Note: If 0 is written to the CST bit during operation with the TIOC pin designated for output, the counter stops but the TIOC pin output compare output level is retained. If TIOR is written to when the CST bit is cleared to 0, the pin output level will be changed to the set initial output value.

9.2.9 Timer Synchro Register (TSYR)

Bit	:	7	6	5	4	3	2	1	0
		—	—	SYNC5	SYNC4	SYNC3	SYNC2	SYNC1	SYNC0
Initial value :		0	0	0	0	0	0	0	0
R/W	:	—	—	R/W	R/W	R/W	R/W	R/W	R/W

TSYR is an 8-bit readable/writable register that selects independent operation or synchronous operation for the channel 0 to 4 TCNT counters. A channel performs synchronous operation when the corresponding bit in TSYR is set to 1.

TSYR is initialized to H'00 by a reset and in hardware standby mode.

Bits 7 and 6—Reserved: Must always be written with 0.

Bits 5 to 0—Timer Synchro 5 to 0 (SYNC5 to SYNC0): These bits select whether operation is independent of or synchronized with other channels.

When synchronous operation is selected, synchronous presetting of multiple channels^{*1}, and synchronous clearing through counter clearing on another channel^{*2} are possible.

- Notes:
1. To set synchronous operation, the SYNC bits for at least two channels must be set to 1.
 2. To set synchronous clearing, in addition to the SYNC bit, the TCNT clearing source must also be set by means of bits CCLR2 to CCLR0 in TCR.

Bit n SYNCn	Description
0	TCNTn operates independently (TCNT presetting/clearing is unrelated to other channels) (Initial value)
1	TCNTn performs synchronous operation TCNT synchronous presetting/synchronous clearing is possible

n = 5 to 0

9.2.10 Module Stop Control Register (MSTPCR)

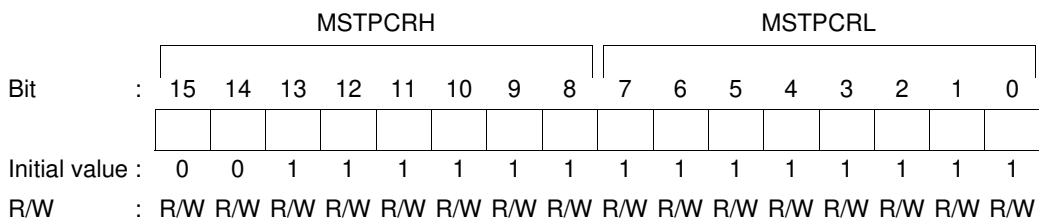

MSTPCR is a 16-bit readable/writable register that performs module stop mode control.

When the MSTP13 bit in MSTPCR is set to 1, TPU operation stops at the end of the bus cycle and a transition is made to module stop mode. Registers cannot be read or written to in module stop mode. For details, see section 19.5, Module Stop Mode.

MSTPCR is initialized to H'3FFF by a reset and in hardware standby mode. It is not initialized in software standby mode.

Bit 13—Module Stop (MSTP13): Specifies the TPU module stop mode.

Bit 13 MSTP13	Description
0	TPU module stop mode cleared
1	TPU module stop mode set (Initial value)

9.3 Interface to Bus Master

9.3.1 16-Bit Registers

TCNT and TGR are 16-bit registers. As the data bus to the bus master is 16 bits wide, these registers can be read and written to in 16-bit units.

These registers cannot be read or written to in 8-bit units; 16-bit access must always be used.

An example of 16-bit register access operation is shown in figure 9.2.

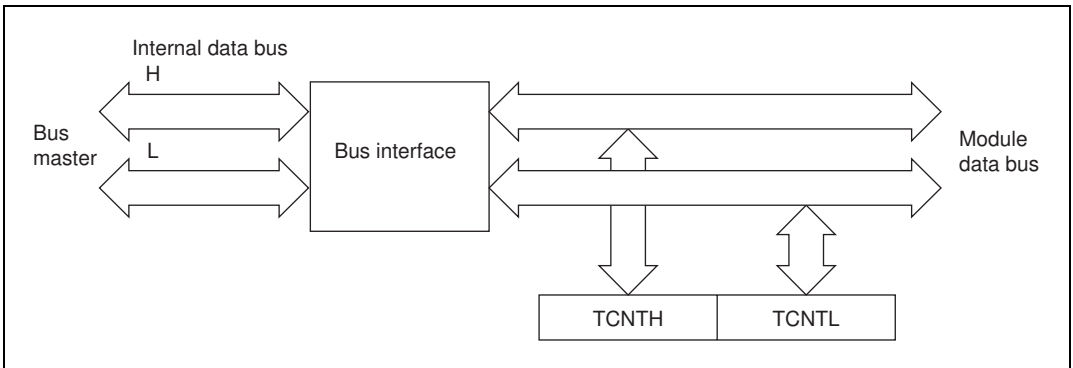

Figure 9.2 16-Bit Register Access Operation [Bus Master ↔ TCNT (16 Bits)]

9.3.2 8-Bit Registers

Registers other than TCNT and TGR are 8-bit. As the data bus to the CPU is 16 bits wide, these registers can be read and written to in 16-bit units. They can also be read and written to in 8-bit units.

Examples of 8-bit register access operation are shown in figures 9.3 to 9.5.

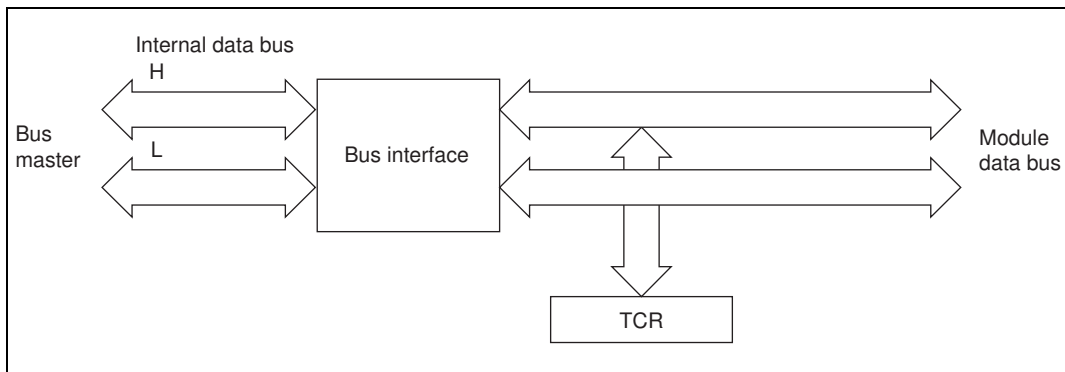

Figure 9.3 8-Bit Register Access Operation [Bus Master ↔ TCR (Upper 8 Bits)]

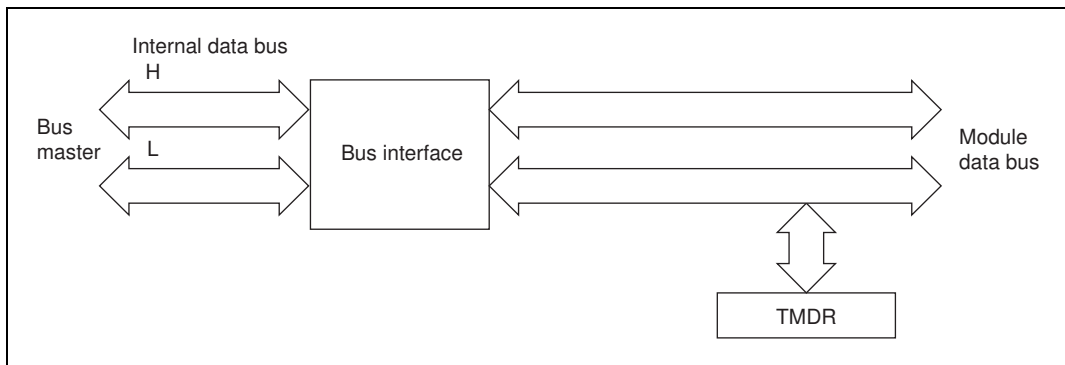

Figure 9.4 8-Bit Register Access Operation [Bus Master ↔ TMDR (Lower 8 Bits)]

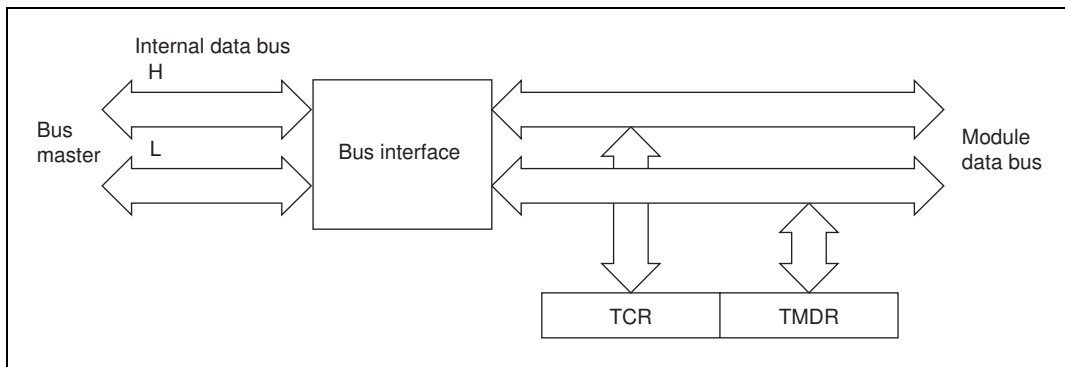

Figure 9.5 8-Bit Register Access Operation [Bus Master ↔ TCR and TMDR (16 Bits)]

9.4 Operation

9.4.1 Overview

Operation in each mode is outlined below.

Normal Operation: Each channel has a TCNT and TGR register. TCNT performs up-counting, and is also capable of free-running operation, synchronous counting, and external event counting.

Each TGR can be used as an input capture register or output compare register.

Synchronous Operation: When synchronous operation is designated for a channel, TCNT for that channel performs synchronous presetting. That is, when TCNT for a channel designated for synchronous operation is rewritten, the TCNT counters for the other channels are also rewritten at the same time. Synchronous clearing of the TCNT counters is also possible by setting the timer synchronization bits in TSYR for channels designated for synchronous operation.

Buffer Operation

- When TGR is an output compare register
When a compare match occurs, the value in the buffer register for the relevant channel is transferred to TGR.
- When TGR is an input capture register
When input capture occurs, the value in TCNT is transferred to TGR and the value previously held in TGR is transferred to the buffer register.

Cascaded Operation: The channel 1 counter (TCNT1) and channel 2 counter (TCNT2), or the channel 4 counter (TCNT4) and channel 5 counter (TCNT5), can be connected together to operate as a 32-bit counter.

PWM Mode: In this mode, a PWM waveform is output. The output level can be set by means of TIOR. A PWM waveform with a duty of between 0% and 100% can be output, according to the setting of each TGR register.

Phase Counting Mode: In this mode, TCNT is incremented or decremented by detecting the phases of two clocks input from the external clock input pins in channels 1, 2, 4, and 5. When phase counting mode is set, the corresponding TCLK pin functions as the clock pin, and TCNT performs up/down-counting.

This can be used for two-phase encoder pulse input.

9.4.2 Basic Functions

Counter Operation: When one of bits CST0 to CST5 is set to 1 in TSTR, the TCNT counter for the corresponding channel starts counting. TCNT can operate as a free-running counter, periodic counter, and so on.

- Example of count operation setting procedure

Figure 9.6 shows an example of the count operation setting procedure.

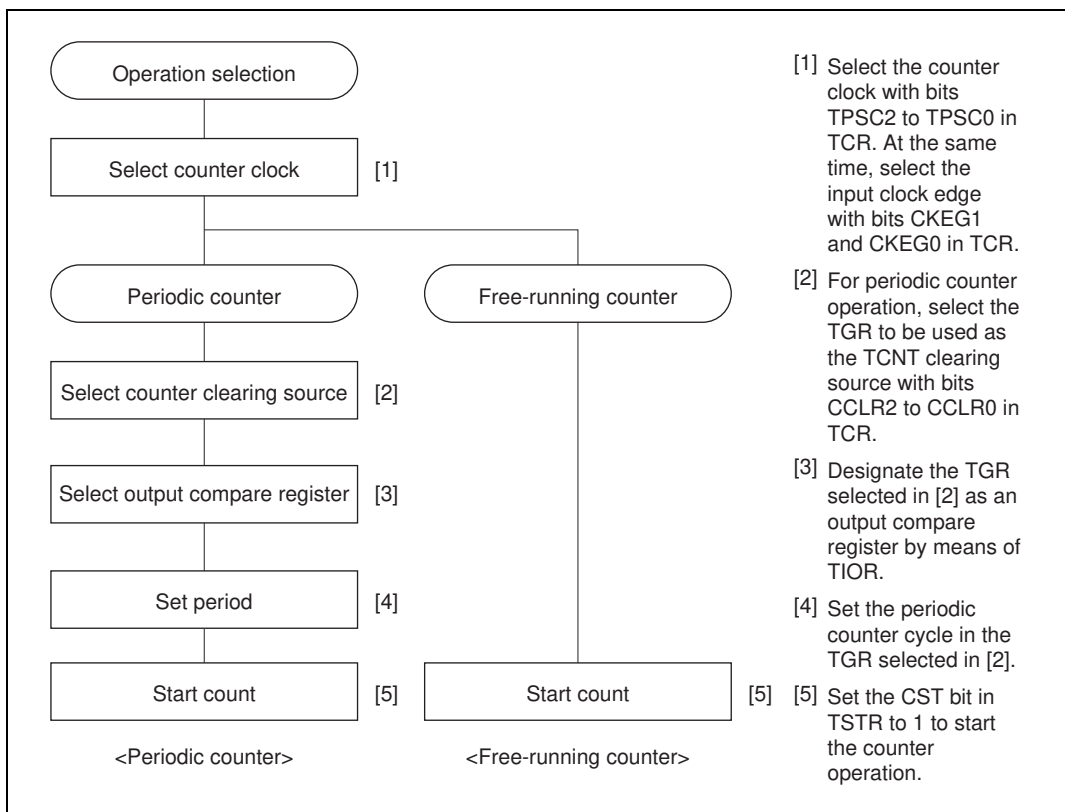

Figure 9.6 Example of Counter Operation Setting Procedure

- Free-running count operation and periodic count operation

Immediately after a reset, the TPU's TCNT counters are all designated as free-running counters. When the relevant bit in TSTR is set to 1 the corresponding TCNT counter starts up-count operation as a free-running counter. When TCNT overflows (from H'FFFF to H'0000), the TCFV bit in TSR is set to 1. If the value of the corresponding TCIEV bit in TIER is 1 at this point, the TPU requests an interrupt. After overflow, TCNT starts counting up again from H'0000.

Figure 9.7 illustrates free-running counter operation.

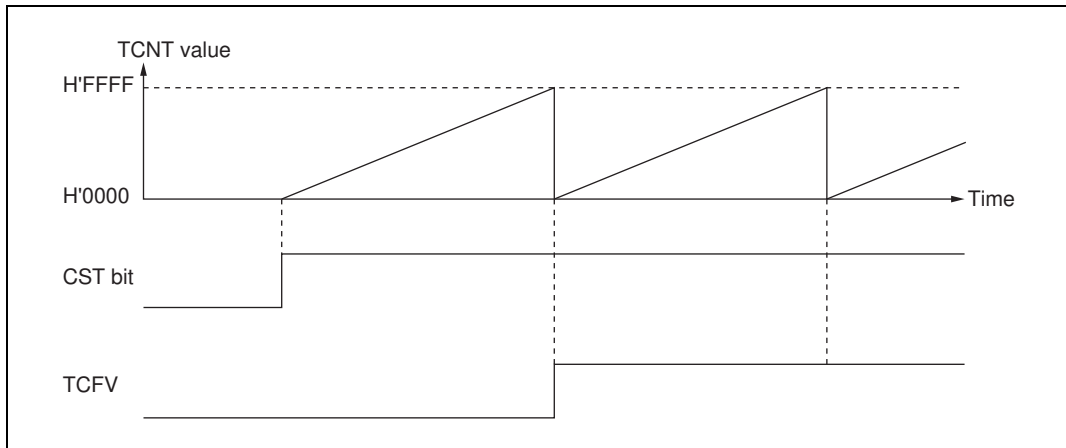

Figure 9.7 Free-Running Counter Operation

When compare match is selected as the TCNT clearing source, the TCNT counter for the relevant channel performs periodic count operation. The TGR register for setting the period is designated as an output compare register, and counter clearing by compare match is selected by means of bits CCLR2 to CCLR0 in TCR. After the settings have been made, TCNT starts up-count operation as a periodic counter when the corresponding bit in TSTR is set to 1. When the count value matches the value in TGR, the TGF bit in TSR is set to 1 and TCNT is cleared to H'0000.

If the value of the corresponding TGIE bit in TIER is 1 at this point, the TPU requests an interrupt. After a compare match, TCNT starts counting up again from H'0000.

Figure 9.8 illustrates periodic counter operation.

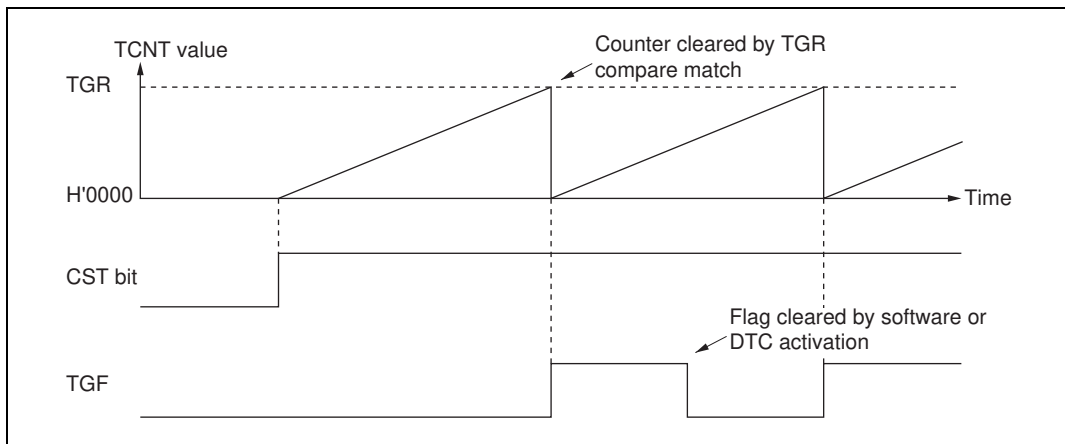

Figure 9.8 Periodic Counter Operation

Waveform Output by Compare Match: The TPU can perform 0, 1, or toggle output from the corresponding output pin using compare match.

- Example of setting procedure for waveform output by compare match

Figure 9.9 shows an example of the setting procedure for waveform output by compare match

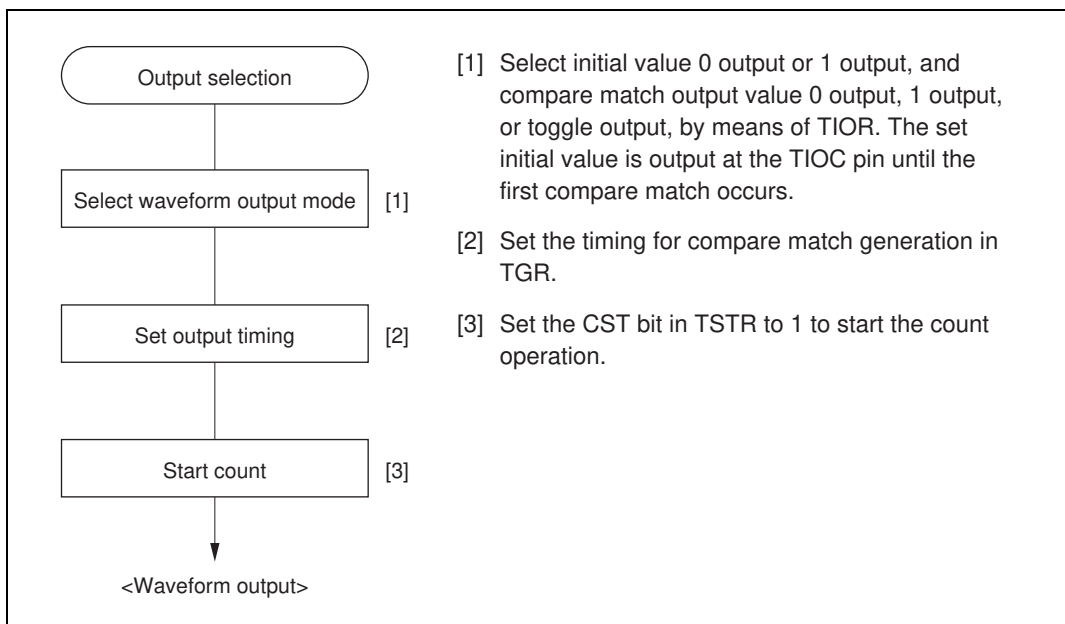

Figure 9.9 Example of Setting Procedure for Waveform Output by Compare Match

- Examples of waveform output operation

Figure 9.10 shows an example of 0 output/1 output.

In this example TCNT has been designated as a free-running counter, and settings have been made so that 1 is output by compare match A, and 0 is output by compare match B. When the set level and the pin level coincide, the pin level does not change.

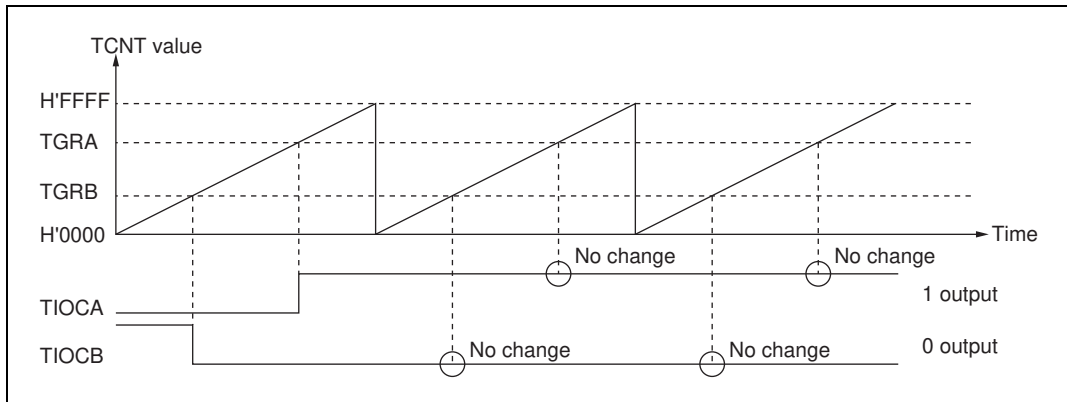

Figure 9.10 Example of 0 Output/1 Output Operation

Figure 9.11 shows an example of toggle output.

In this example TCNT has been designated as a periodic counter (with counter clearing performed by compare match B), and settings have been made so that output is toggled by both compare match A and compare match B.

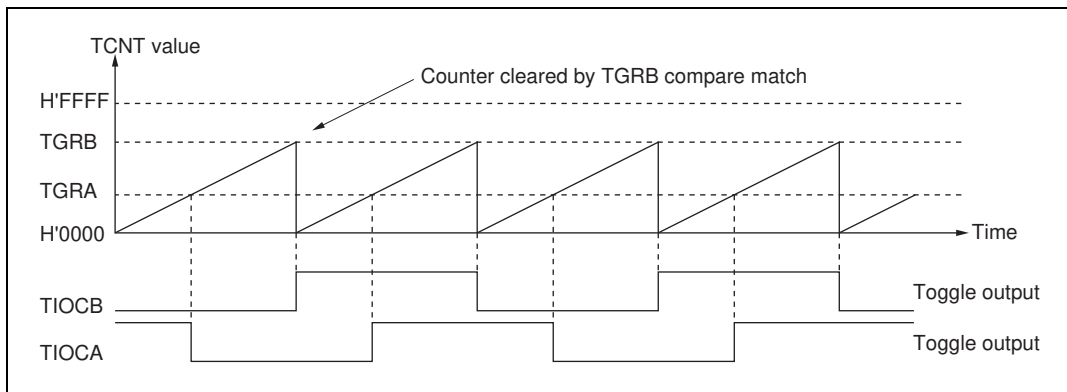

Figure 9.11 Example of Toggle Output Operation

Input Capture Function: The TCNT value can be transferred to TGR on detection of the TIOC pin input edge.

Rising edge, falling edge, or both edges can be selected as the detected edge. For channels 0, 1, 3, and 4, it is also possible to specify another channel's counter input clock or compare match signal as the input capture source.

Note: When another channel's counter input clock is used as the input capture input for channels 0 and 3, $\phi/1$ should not be selected as the counter input clock used for input capture input. Input capture will not be generated if $\phi/1$ is selected.

- Example of input capture operation setting procedure

Figure 9.12 shows an example of the input capture operation setting procedure.

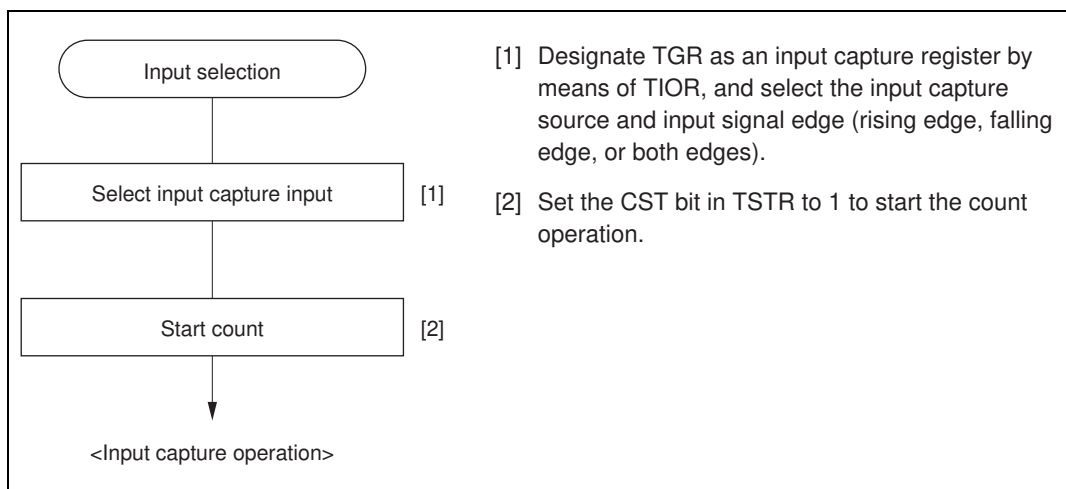

Figure 9.12 Example of Input Capture Operation Setting Procedure

- Example of input capture operation

Figure 9.13 shows an example of input capture operation.

In this example both rising and falling edges have been selected as the TIOCA pin input capture input edge, falling edge has been selected as the TIOCB pin input capture input edge, and counter clearing by TGRB input capture has been designated for TCNT.

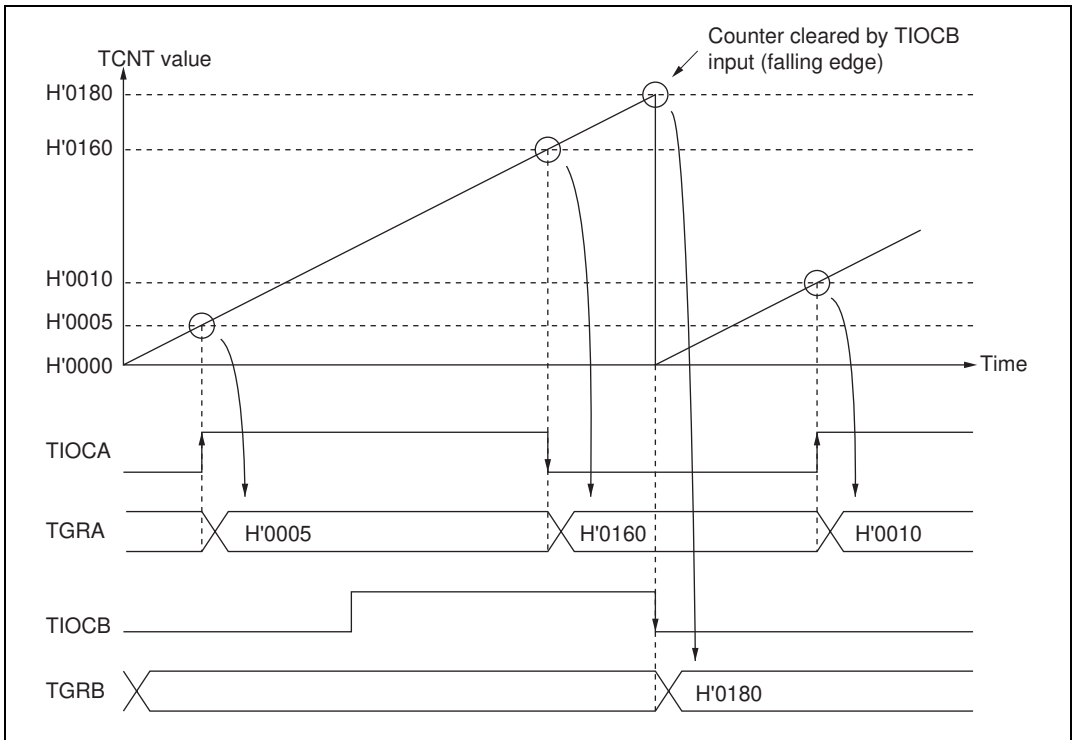

Figure 9.13 Example of Input Capture Operation

9.4.3 Synchronous Operation

In synchronous operation, the values in a number of TCNT counters can be rewritten simultaneously (synchronous presetting). Also, a number of TCNT counters can be cleared simultaneously by making the appropriate setting in TCR (synchronous clearing).

Synchronous operation enables TGR to be incremented with respect to a single time base.

Channels 0 to 5 can all be designated for synchronous operation.

Example of Synchronous Operation Setting Procedure: Figure 9.14 shows an example of the synchronous operation setting procedure.

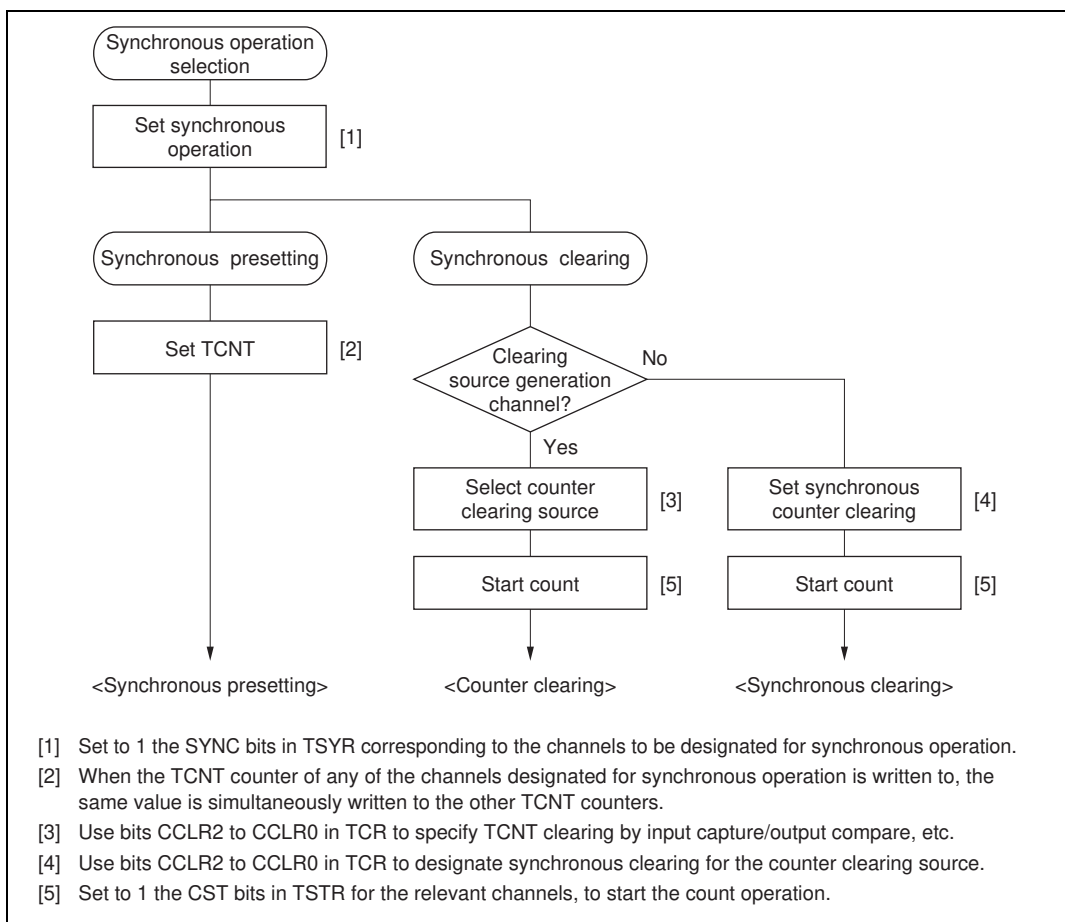

Figure 9.14 Example of Synchronous Operation Setting Procedure

Example of Synchronous Operation: Figure 9.15 shows an example of synchronous operation.

In this example, synchronous operation and PWM mode 1 have been designated for channels 0 to 2, TGR0B compare match has been set as the channel 0 counter clearing source, and synchronous clearing has been set for the channel 1 and 2 counter clearing sources.

Three-phase PWM waveforms are output from pins TIOC0A, TIOC1A, and TIOC2A. At this time, synchronous presetting, and synchronous clearing by TGR0B compare match, is performed for channel 0 to 2 TCNT counters, and the data set in TGR0B is used as the PWM cycle.

For details of PWM modes, see section 9.4.6, PWM Modes.

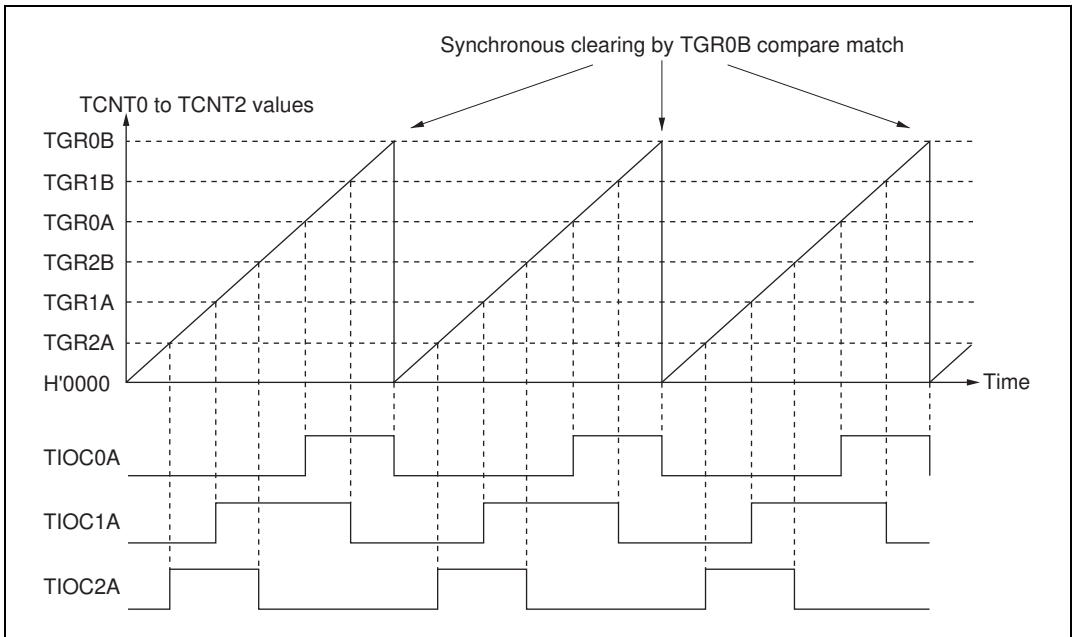

Figure 9.15 Example of Synchronous Operation

9.4.4 Buffer Operation

Buffer operation, provided for channels 0 and 3, enables TGRC and TGRD to be used as buffer registers.

Buffer operation differs depending on whether TGR has been designated as an input capture register or as a compare match register.

Table 9.5 shows the register combinations used in buffer operation.

Table 9.5 Register Combinations in Buffer Operation

Channel	Timer General Register	Buffer Register
0	TGR0A	TGR0C
	TGR0B	TGR0D
3	TGR3A	TGR3C
	TGR3B	TGR3D

- When TGR is an output compare register

When a compare match occurs, the value in the buffer register for the corresponding channel is transferred to the timer general register.

This operation is illustrated in figure 9.16.

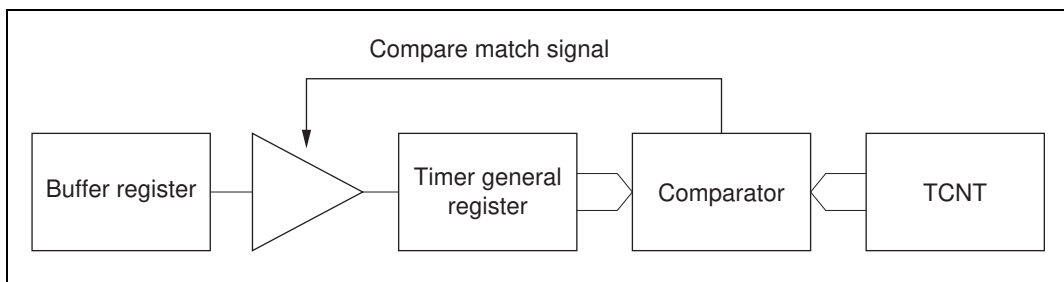

Figure 9.16 Compare Match Buffer Operation

- When TGR is an input capture register

When input capture occurs, the value in TCNT is transferred to TGR and the value previously held in the timer general register is transferred to the buffer register.

This operation is illustrated in figure 9.17.

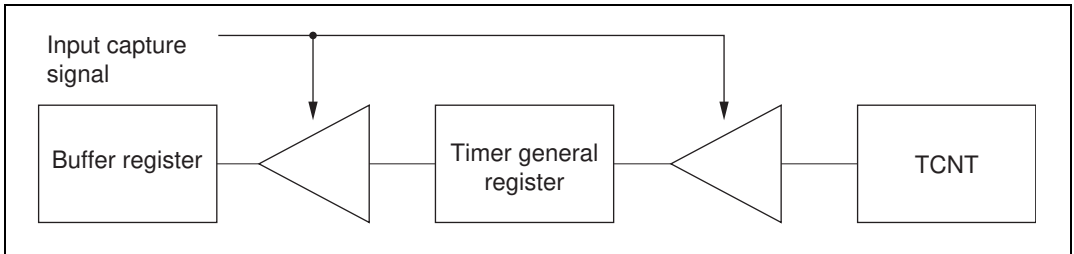

Figure 9.17 Input Capture Buffer Operation

Example of Buffer Operation Setting Procedure: Figure 9.18 shows an example of the buffer operation setting procedure.

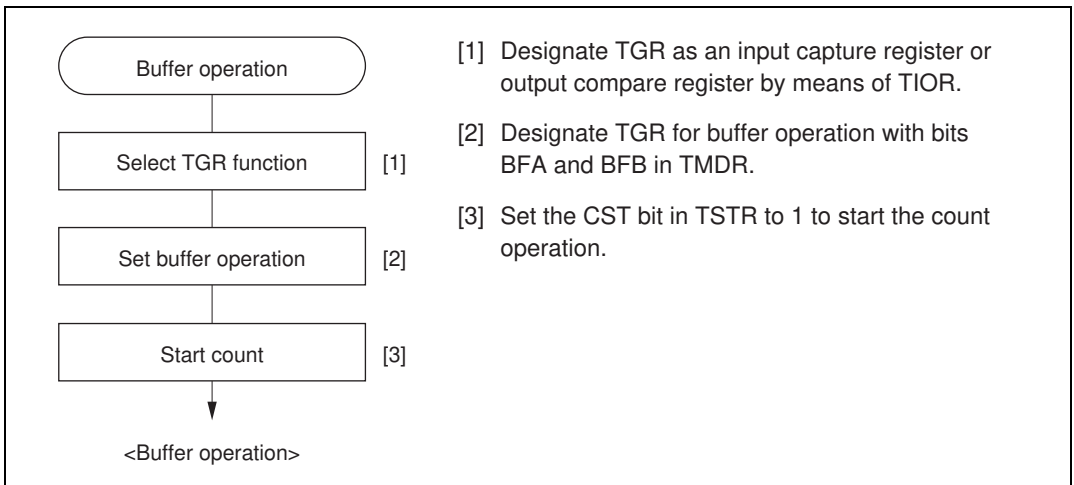

Figure 9.18 Example of Buffer Operation Setting Procedure

Examples of Buffer Operation

- When TGR is an output compare register

Figure 9.19 shows an operation example in which PWM mode 1 has been designated for channel 0, and buffer operation has been designated for TGRA and TGRC. The settings used in this example are TCNT clearing by compare match B, 1 output at compare match A, and 0 output at compare match B.

As buffer operation has been set, when compare match A occurs the output changes and the value in buffer register TGRC is simultaneously transferred to timer general register TGRA. This operation is repeated each time compare match A occurs.

For details of PWM modes, see section 9.4.6, PWM Modes.

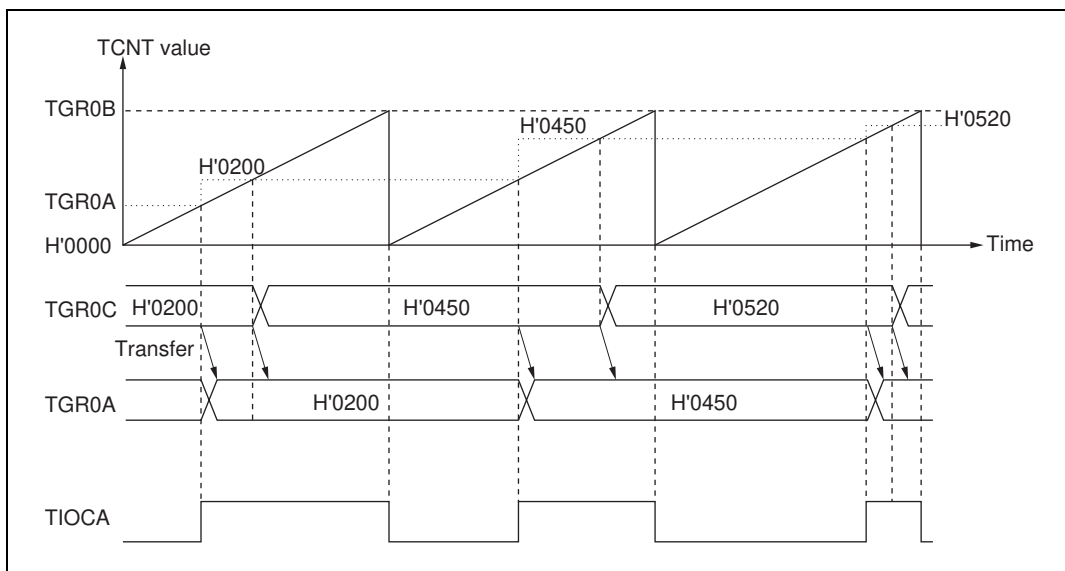

Figure 9.19 Example of Buffer Operation (1)

- When TGR is an input capture register

Figure 9.20 shows an operation example in which TGRA has been designated as an input capture register, and buffer operation has been designated for TGRA and TGRC.

Counter clearing by TGRA input capture has been set for TCNT, and both rising and falling edges have been selected as the TIOCA pin input capture input edge.

As buffer operation has been set, when the TCNT value is stored in TGRA upon occurrence of input capture A, the value previously stored in TGRA is simultaneously transferred to TGRC.

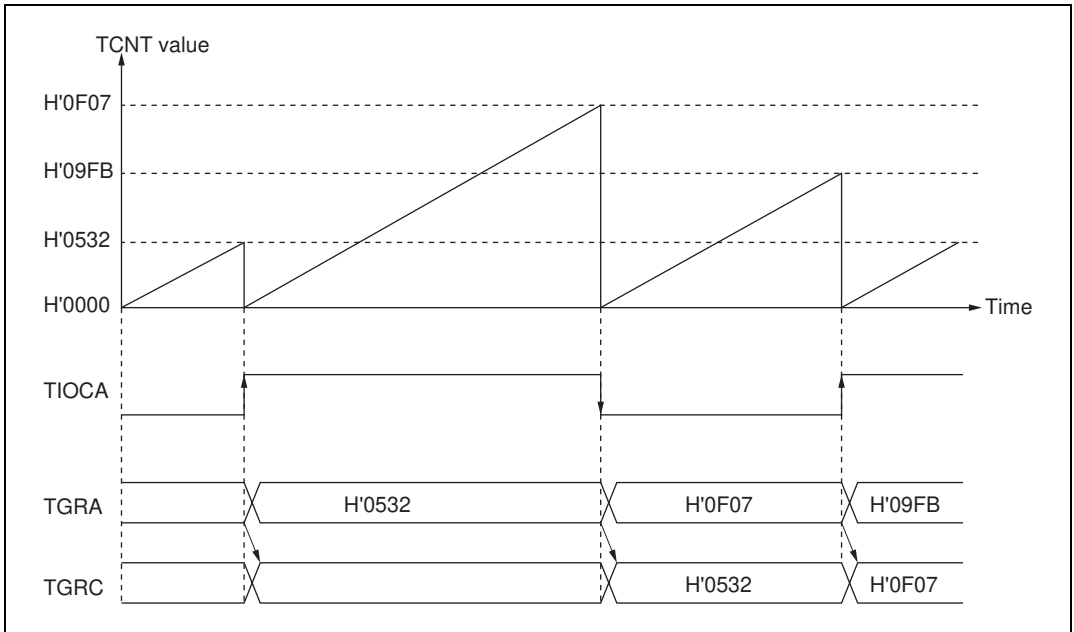

Figure 9.20 Example of Buffer Operation (2)

9.4.5 Cascaded Operation

In cascaded operation, two 16-bit counters for different channels are used together as a 32-bit counter.

This function works by counting the channel 1 (channel 4) counter clock upon overflow/underflow of TCNT2 (TCNT5) as set in bits TPSC2 to TPSC0 in TCR.

Underflow occurs only when the lower 16-bit TCNT is in phase-counting mode.

Table 9.6 shows the register combinations used in cascaded operation.

Note: When phase counting mode is set for channel 1 or 4, the counter clock setting is invalid and the counter operates independently in phase counting mode.

Table 9.6 Cascaded Combinations

Combination	Upper 16 Bits	Lower 16 Bits
Channels 1 and 2	TCNT1	TCNT2
Channels 4 and 5	TCNT4	TCNT5

Example of Cascaded Operation Setting Procedure: Figure 9.21 shows an example of the setting procedure for cascaded operation.

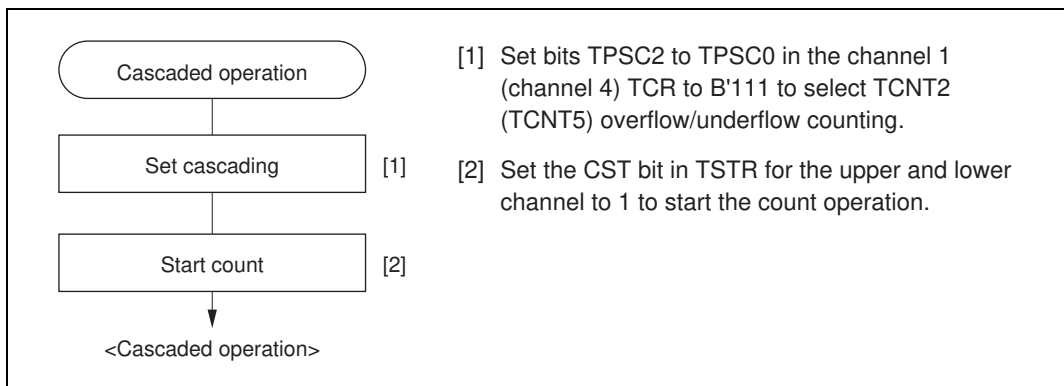

Figure 9.21 Cascaded Operation Setting Procedure

Examples of Cascaded Operation: Figure 9.22 illustrates the operation when counting upon TCNT2 overflow/underflow has been set for TCNT1, TGR1A and TGR2A have been designated as input capture registers, and TIOC pin rising edge has been selected.

When a rising edge is input to the TIOCA1 and TIOCA2 pins simultaneously, the upper 16 bits of the 32-bit data are transferred to TGR1A, and the lower 16 bits to TGR2A.

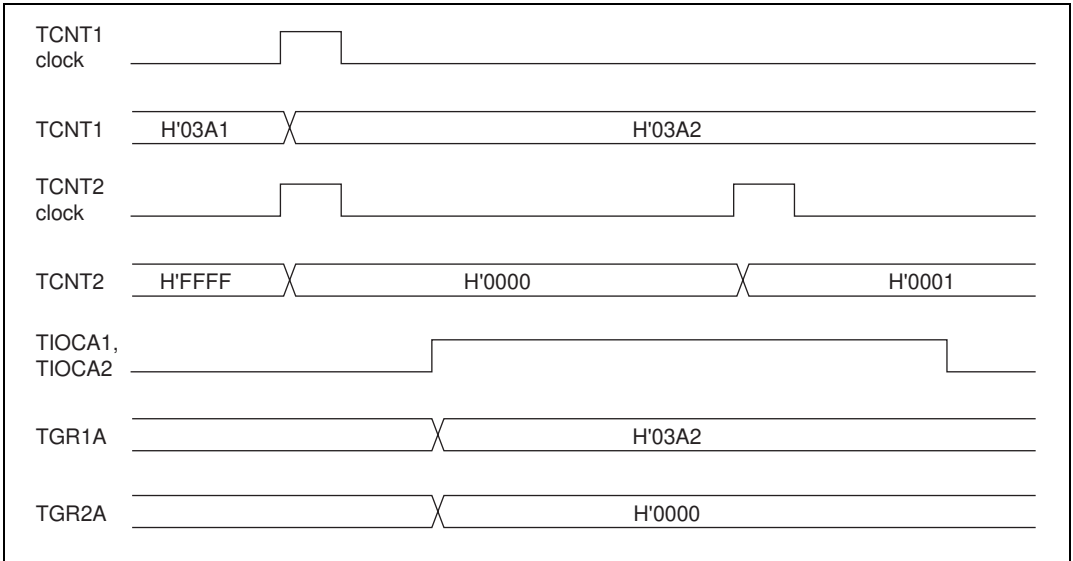

Figure 9.22 Example of Cascaded Operation (1)

Figure 9.23 illustrates the operation when counting upon TCNT2 overflow/underflow has been set for TCNT1, and phase counting mode has been designated for channel 2.

TCNT1 is incremented by TCNT2 overflow and decremented by TCNT2 underflow.

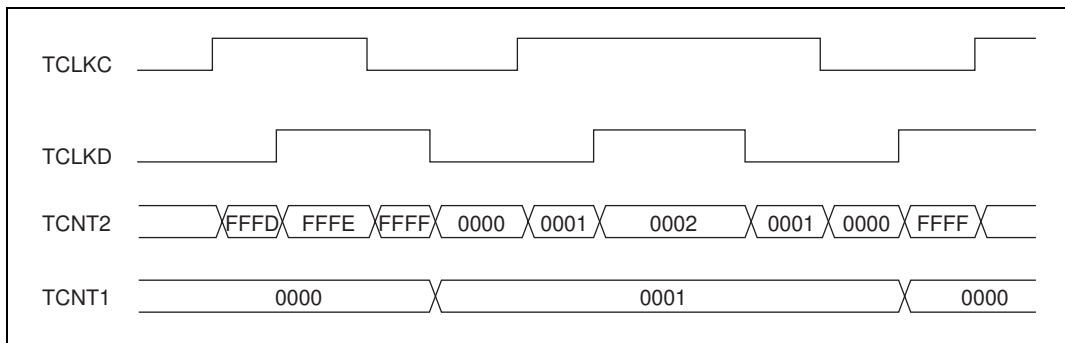

Figure 9.23 Example of Cascaded Operation (2)

9.4.6 PWM Modes

In PWM mode, PWM waveforms are output from the output pins. 0, 1, or toggle output can be selected as the output level in response to compare match of each TGR.

Designating TGR compare match as the counter clearing source enables the period to be set in that register. All channels can be designated for PWM mode independently. Synchronous operation is also possible.

There are two PWM modes, as described below.

- PWM mode 1

PWM output is generated from the TIOCA and TIOCC pins by pairing TGRA with TGRB and TGRC with TGRD. The output specified by bits IOA3 to IOA0 and IOC3 to IOC0 in TIOR is output from the TIOCA and TIOCC pins at compare matches A and C, and the output specified by bits IOB3 to IOB0 and IOD3 to IOD0 in TIOR is output at compare matches B and D. The initial output value is the value set in TGRA or TGRC. If the set values of paired TGRs are identical, the output value does not change when a compare match occurs.

In PWM mode 1, a maximum 8-phase PWM output is possible.

- PWM mode 2

PWM output is generated using one TGR as the period register and the others as duty registers. The output specified in TIOR is performed by means of compare matches. Upon counter clearing by a synchronization register compare match, the output value of each pin is the initial value set in TIOR. If the set values of the period and duty registers are identical, the output value does not change when a compare match occurs.

In PWM mode 2, a maximum 15-phase PWM output is possible by combined use with synchronous operation.

The correspondence between PWM output pins and registers is shown in table 9.7.

Table 9.7 PWM Output Registers and Output Pins

Channel	Registers	Output Pins	
		PWM Mode 1	PWM Mode 2
0	TGR0A	TIOCA0	TIOCA0
	TGR0B		TIOCB0
	TGR0C	TIOCC0	TIOCC0
	TGR0D		TIOCD0
1	TGR1A	TIOCA1	TIOCA1
	TGR1B		TIOCB1
2	TGR2A	TIOCA2	TIOCA2
	TGR2B		TIOCB2
3	TGR3A	TIOCA3	TIOCA3
	TGR3B		TIOCB3
	TGR3C	TIOCC3	TIOCC3
	TGR3D		TIOCD3
4	TGR4A	TIOCA4	TIOCA4
	TGR4B		TIOCB4
5	TGR5A	TIOCA5	TIOCA5
	TGR5B		TIOCB5

Note: In PWM mode 2, PWM output is not possible for the TGR register in which the period is set.

Example of PWM Mode Setting Procedure: Figure 9.24 shows an example of the PWM mode setting procedure.

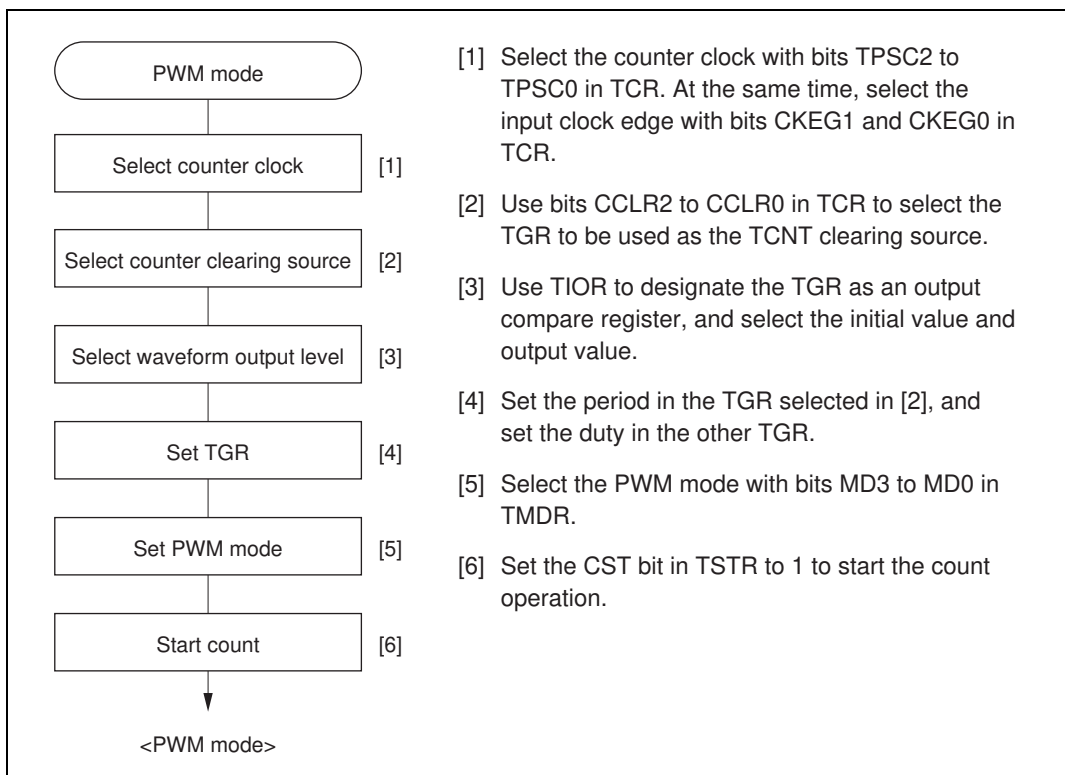

Figure 9.24 Example of PWM Mode Setting Procedure

Examples of PWM Mode Operation: Figure 9.25 shows an example of PWM mode 1 operation.

In this example, TGRA compare match is set as the TCNT clearing source, 0 is set for the TGRA initial output value and output value, and 1 is set as the TGRB output value.

In this case, the value set in TGRA is used as the period, and the value set in TGRB as the duty.

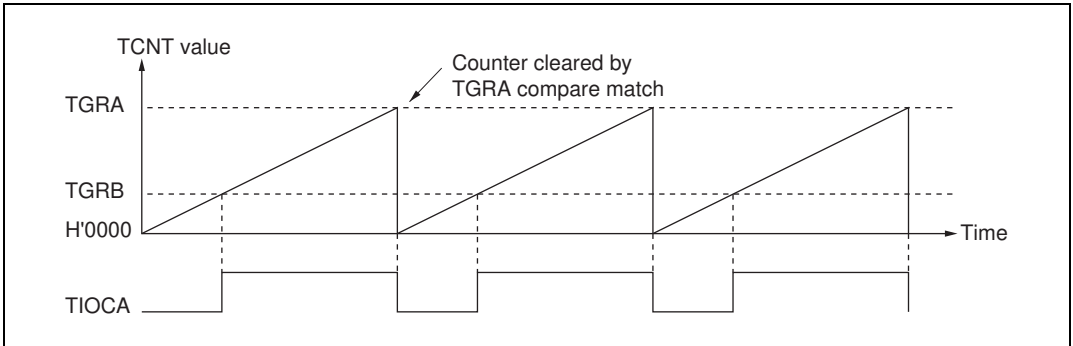

Figure 9.25 Example of PWM Mode Operation (1)

Figure 9.26 shows an example of PWM mode 2 operation.

In this example, synchronous operation is designated for channels 0 and 1, TGR1B compare match is set as the TCNT clearing source, and 0 is set for the initial output value and 1 for the output value of the other TGR registers (TGR0A to TGR0D, TGR1A), to output a 5-phase PWM waveform.

In this case, the value set in TGR1B is used as the period, and the values set in the other TGR registers as the duty.

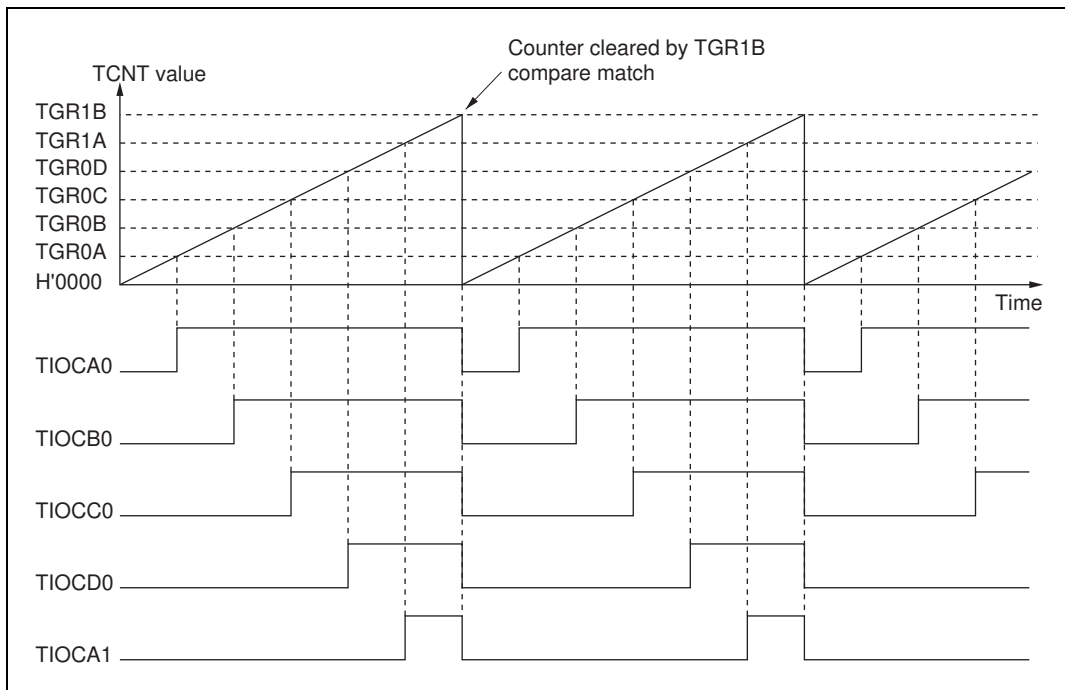

Figure 9.26 Example of PWM Mode Operation (2)

Figure 9.27 shows examples of PWM waveform output with 0% duty and 100% duty in PWM mode.

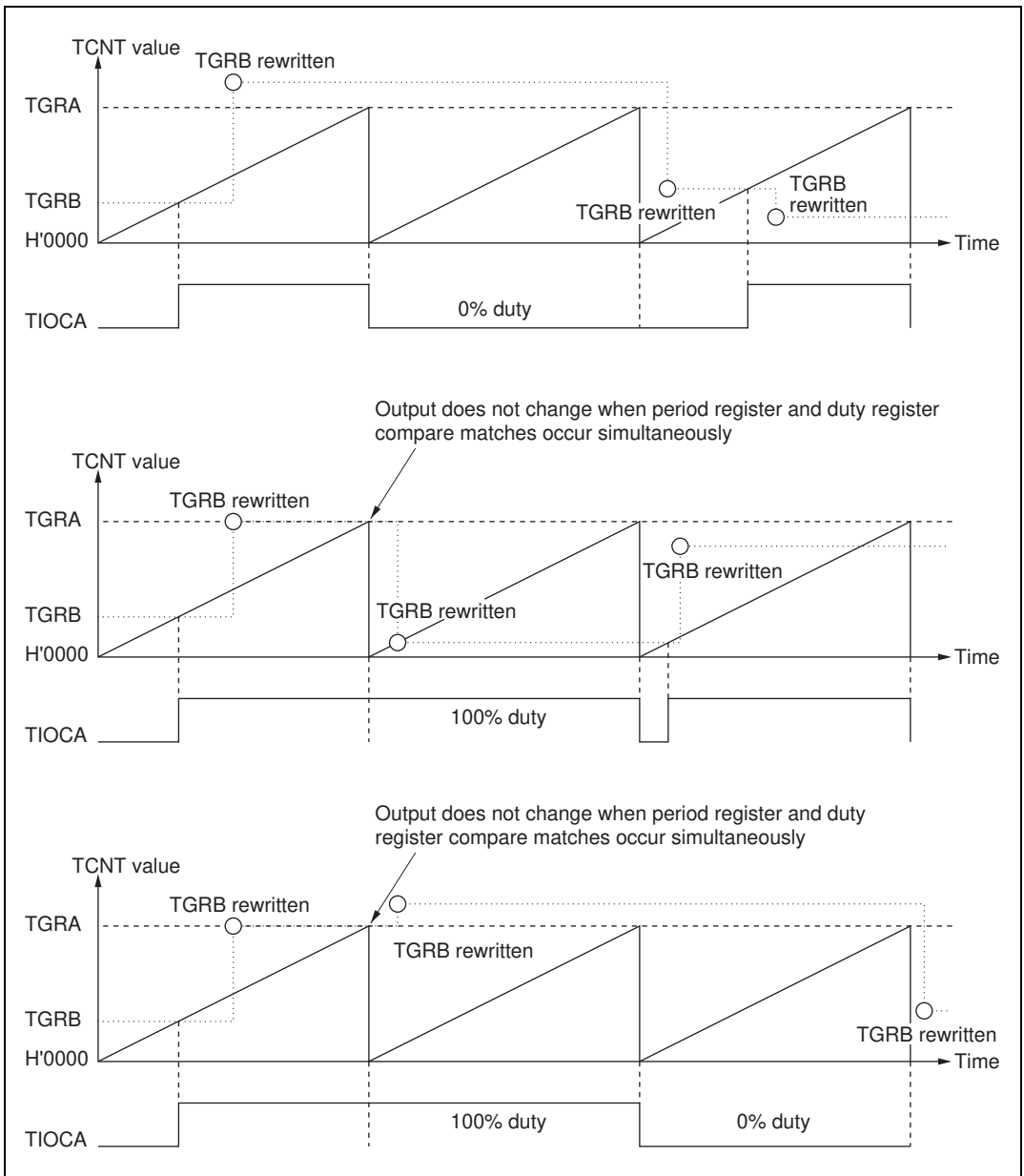

Figure 9.27 Examples of PWM Mode Operation (3)

9.4.7 Phase Counting Mode

In phase counting mode, the phase difference between two external clock inputs is detected and TCNT is incremented/decremented accordingly. This mode can be set for channels 1, 2, 4, and 5.

When phase counting mode is set, an external clock is selected as the counter input clock and TCNT operates as an up/down-counter regardless of the setting of bits TPSC2 to TPSC0 and bits CKEG1 and CKEG0 in TCR. However, the functions of bits CCLR1 and CCLR0 in TCR, and of TIOR, TIER, and TGR are valid, and input capture/compare match and interrupt functions can be used.

When overflow occurs while TCNT is counting up, the TCFV flag in TSR is set; when underflow occurs while TCNT is counting down, the TCFU flag is set.

The TCFD bit in TSR is the count direction flag. Reading the TCFD flag provides an indication of whether TCNT is counting up or down.

Table 9.8 shows the correspondence between external clock pins and channels.

Table 9.8 Phase Counting Mode Clock Input Pins

Channels	External Clock Pins	
	A-Phase	B-Phase
When channel 1 or 5 is set to phase counting mode	TCLKA	TCLKB
When channel 2 or 4 is set to phase counting mode	TCLKC	TCLKD

Example of Phase Counting Mode Setting Procedure: Figure 9.28 shows an example of the phase counting mode setting procedure.

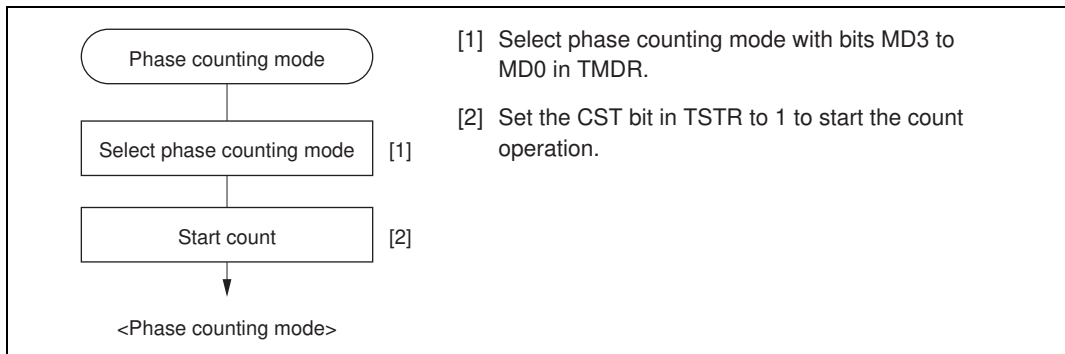

Figure 9.28 Example of Phase Counting Mode Setting Procedure

Examples of Phase Counting Mode Operation: In phase counting mode, TCNT counts up or down according to the phase difference between two external clocks. There are four modes, according to the count conditions.

- Phase counting mode 1

Figure 9.29 shows an example of phase counting mode 1 operation, and table 9.9 summarizes the TCNT up/down-count conditions.

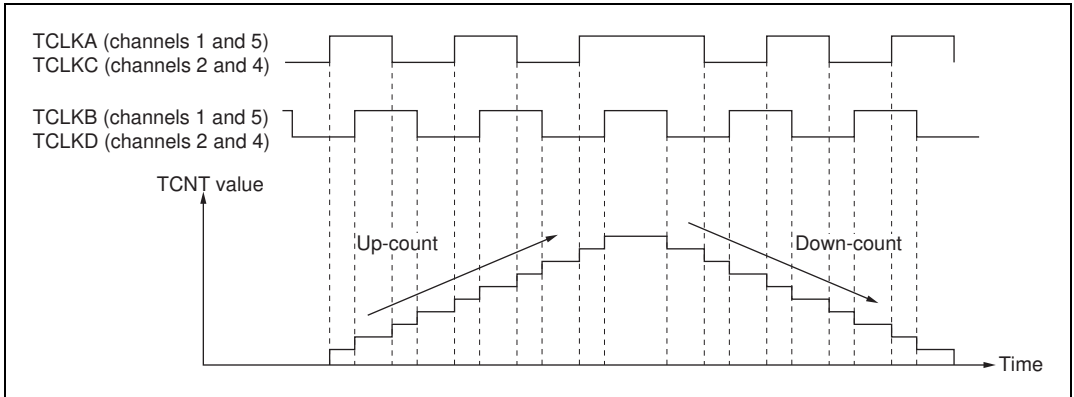

Figure 9.29 Example of Phase Counting Mode 1 Operation

Table 9.9 Up/Down-Count Conditions in Phase Counting Mode 1

TCLKA (Channels 1 and 5) TCLKC (Channels 2 and 4)	TCLKB (Channels 1 and 5) TCLKD (Channels 2 and 4)	Operation
High level		Up-count
Low level		
	Low level	
	High level	
High level		Down-count
Low level		
	High level	
	Low level	

Legend:

: Rising edge

: Falling edge

- Phase counting mode 2

Figure 9.30 shows an example of phase counting mode 2 operation, and table 9.10 summarizes the TCNT up/down-count conditions.

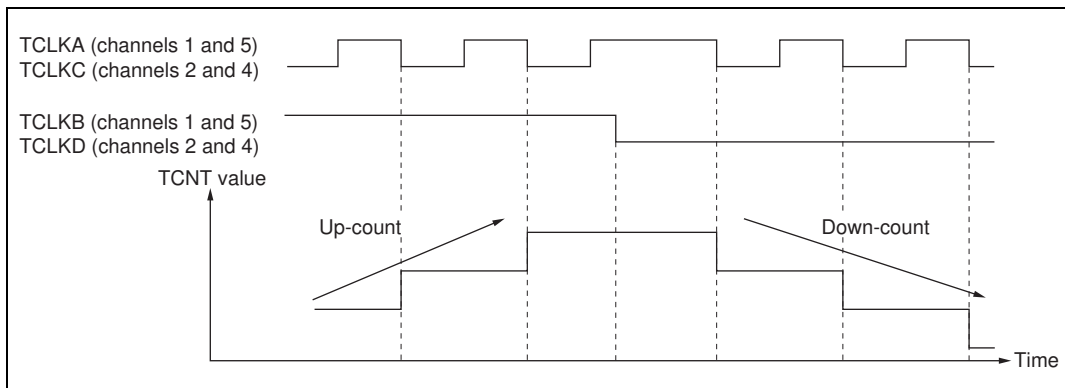

Figure 9.30 Example of Phase Counting Mode 2 Operation

Table 9.10 Up/Down-Count Conditions in Phase Counting Mode 2

TCLKA (Channels 1 and 5) TCLKC (Channels 2 and 4)	TCLKB (Channels 1 and 5) TCLKD (Channels 2 and 4)	Operation
High level		Don't care
Low level		Don't care
	Low level	Don't care
	High level	Up-count
High level		Don't care
Low level		Down-count
	High level	Don't care
	Low level	Down-count

Legend:

: Rising edge

: Falling edge

- Phase counting mode 3

Figure 9.31 shows an example of phase counting mode 3 operation, and table 9.11 summarizes the TCNT up/down-count conditions.

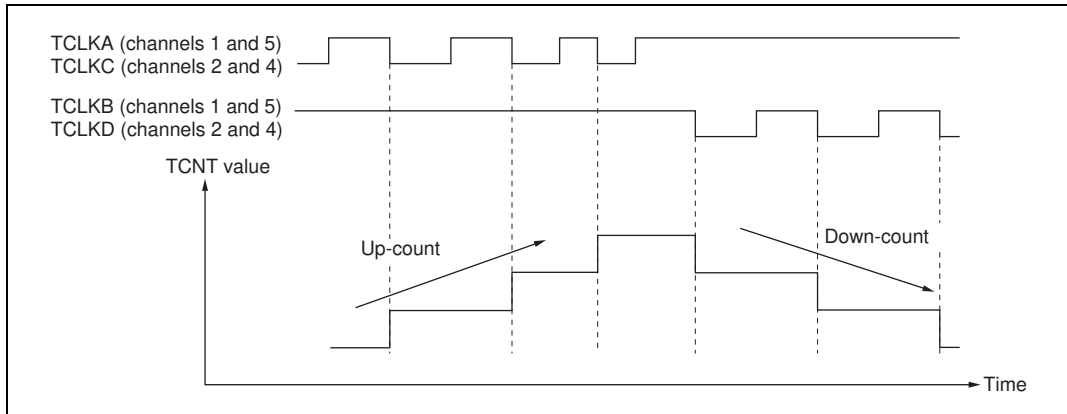

Figure 9.31 Example of Phase Counting Mode 3 Operation

Table 9.11 Up/Down-Count Conditions in Phase Counting Mode 3

TCLKA (Channels 1 and 5) TCLKC (Channels 2 and 4)	TCLKB (Channels 1 and 5) TCLKD (Channels 2 and 4)	Operation
High level		Don't care
Low level		Don't care
	Low level	Up-count
	High level	Up-count
High level		Down-count
Low level		Down-count
	High level	Down-count
	Low level	Down-count

Legend:

: Rising edge

: Falling edge

- Phase counting mode 4

Figure 9.32 shows an example of phase counting mode 4 operation, and table 9.12 summarizes the TCNT up/down-count conditions.

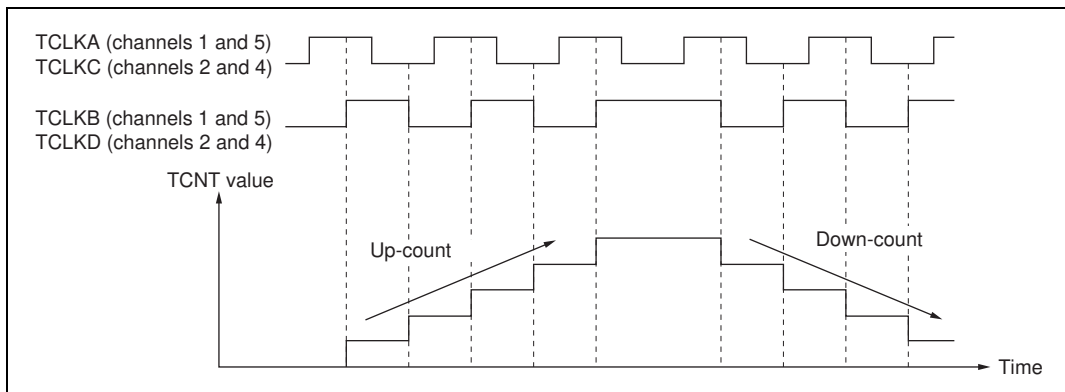

Figure 9.32 Example of Phase Counting Mode 4 Operation

Table 9.12 Up/Down-Count Conditions in Phase Counting Mode 4

TCLKA (Channels 1 and 5) TCLKC (Channels 2 and 4)	TCLKB (Channels 1 and 5) TCLKD (Channels 2 and 4)	Operation
High level		Up-count
Low level		Up-count
	Low level	Don't care
	High level	Don't care
High level		Down-count
Low level		Down-count
	High level	Don't care
	Low level	Don't care

Legend:

: Rising edge

: Falling edge

Phase Counting Mode Application Example: Figure 9.33 shows an example in which phase counting mode is designated for channel 1, and channel 1 is coupled with channel 0 to input servo motor 2-phase encoder pulses in order to detect the position or speed.

Channel 1 is set to phase counting mode 1, and the encoder pulse A-phase and B-phase are input to TCLKA and TCLKB.

Channel 0 operates with TCNT counter clearing by TGR0C compare match; TGR0A and TGR0C are used for the compare match function, and are set with the speed control period and position control period. TGR0B is used for input capture, with TGR0B and TGR0D operating in buffer mode. The channel 1 counter input clock is designated as the TGR0B input capture source, and detection of the pulse width of 2-phase encoder 4-multiplication pulses is performed.

TGR1A and TGR1B for channel 1 are designated for input capture, channel 0 TGR0A and TGR0C compare matches are selected as the input capture source, and store the up/down-counter values for the control periods.

This procedure enables accurate position/speed detection to be achieved.

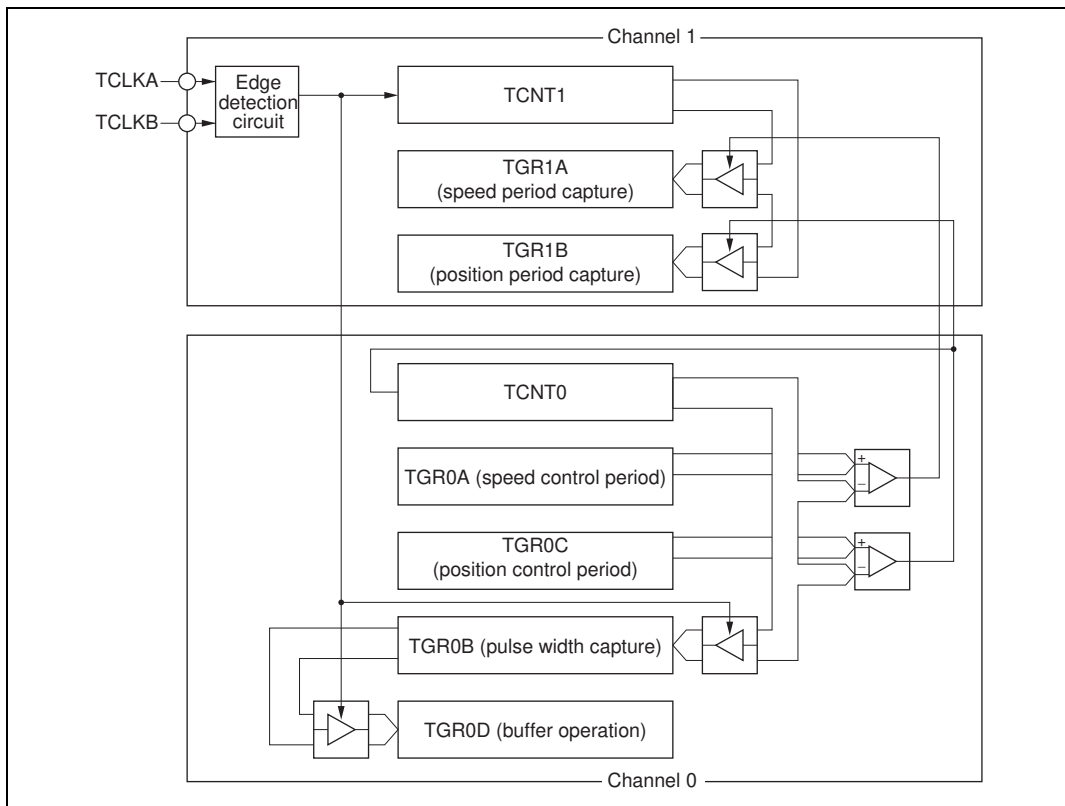

Figure 9.33 Phase Counting Mode Application Example

9.5 Interrupts

9.5.1 Interrupt Sources and Priorities

There are three kinds of TPU interrupt source: TGR input capture/compare match, TCNT overflow, and TCNT underflow. Each interrupt source has its own status flag and enable/disable bit, allowing generation of interrupt request signals to be enabled or disabled individually.

When an interrupt request is generated, the corresponding status flag in TSR is set to 1. If the corresponding enable/disable bit in TIER is set to 1 at this time, an interrupt is requested. The interrupt request is cleared by clearing the status flag to 0.

Relative channel priorities can be changed by the interrupt controller, but the priority order within a channel is fixed. For details, see section 5, Interrupt Controller.

Table 9.13 lists the TPU interrupt sources.

Table 9.13 TPU Interrupts

Channel	Interrupt Source	Description	DTC Activation	Priority
0	TGI0A	TGR0A input capture/compare match	Possible	↑ High
	TGI0B	TGR0B input capture/compare match	Possible	
	TGI0C	TGR0C input capture/compare match	Possible	
	TGI0D	TGR0D input capture/compare match	Possible	
	TCI0V	TCNT0 overflow	Not possible	
1	TGI1A	TGR1A input capture/compare match	Possible	
	TGI1B	TGR1B input capture/compare match	Possible	
	TCI1V	TCNT1 overflow	Not possible	
	TCI1U	TCNT1 underflow	Not possible	
2	TGI2A	TGR2A input capture/compare match	Possible	
	TGI2B	TGR2B input capture/compare match	Possible	
	TCI2V	TCNT2 overflow	Not possible	
	TCI2U	TCNT2 underflow	Not possible	
3	TGI3A	TGR3A input capture/compare match	Possible	
	TGI3B	TGR3B input capture/compare match	Possible	
	TGI3C	TGR3C input capture/compare match	Possible	
	TGI3D	TGR3D input capture/compare match	Possible	
	TCI3V	TCNT3 overflow	Not possible	
4	TGI4A	TGR4A input capture/compare match	Possible	
	TGI4B	TGR4B input capture/compare match	Possible	
	TCI4V	TCNT4 overflow	Not possible	
	TCI4U	TCNT4 underflow	Not possible	
5	TGI5A	TGR5A input capture/compare match	Possible	
	TGI5B	TGR5B input capture/compare match	Possible	
	TCI5V	TCNT5 overflow	Not possible	
	TCI5U	TCNT5 underflow	Not possible	Low

Note: This table shows the initial state immediately after a reset. The relative channel priorities can be changed by the interrupt controller.

Input Capture/Compare Match Interrupt: An interrupt is requested if the TGIE bit in TIER is set to 1 when the TGF flag in TSR is set to 1 by the occurrence of a TGR input capture/compare match on a particular channel. The interrupt request is cleared by clearing the TGF flag to 0. The TPU has 16 input capture/compare match interrupts, four each for channels 0 and 3, and two each for channels 1, 2, 4, and 5.

Overflow Interrupt: An interrupt is requested if the TCIEV bit in TIER is set to 1 when the TCFV flag in TSR is set to 1 by the occurrence of TCNT overflow on a channel. The interrupt request is cleared by clearing the TCFV flag to 0. The TPU has six overflow interrupts, one for each channel.

Underflow Interrupt: An interrupt is requested if the TCIEU bit in TIER is set to 1 when the TCFU flag in TSR is set to 1 by the occurrence of TCNT underflow on a channel. The interrupt request is cleared by clearing the TCFU flag to 0. The TPU has four underflow interrupts, one each for channels 1, 2, 4, and 5.

9.5.2 DTC Activation

The DTC can be activated by the TGR input capture/compare match interrupt for a channel. For details, see section 7, Data Transfer Controller.

A total of 16 TPU input capture/compare match interrupts can be used as DTC activation sources, four each for channels 0 and 3, and two each for channels 1, 2, 4, and 5.

9.5.3 A/D Converter Activation

The A/D converter can be activated by the TGRA input capture/compare match for a channel.

If the TTGE bit in TIER is set to 1 when the TGFA flag in TSR is set to 1 by the occurrence of a TGRA input capture/compare match on a particular channel, a request to start A/D conversion is sent to the A/D converter. If the TPU conversion start trigger has been selected on the A/D converter side at this time, A/D conversion is started.

In the TPU, a total of six TGRA input capture/compare match interrupts can be used as A/D converter conversion start sources, one for each channel.

9.6 Operation Timing

9.6.1 Input/Output Timing

TCNT Count Timing: Figure 9.34 shows TCNT count timing in internal clock operation, and figure 9.35 shows TCNT count timing in external clock operation.

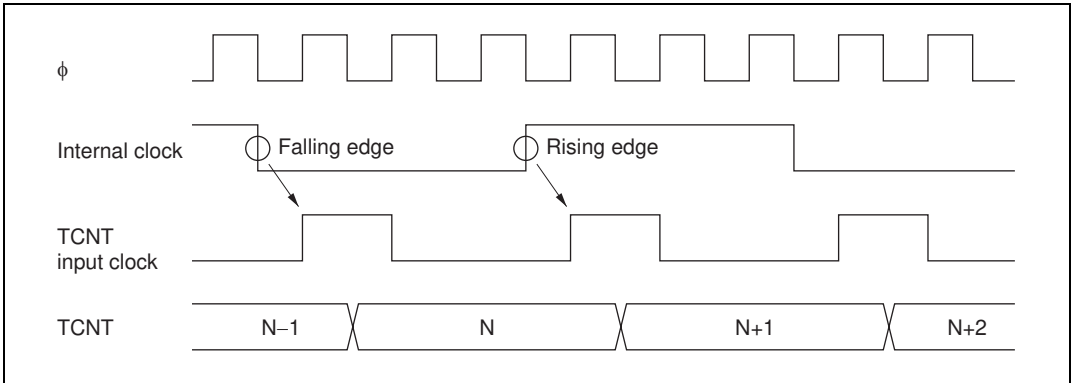

Figure 9.34 Count Timing in Internal Clock Operation

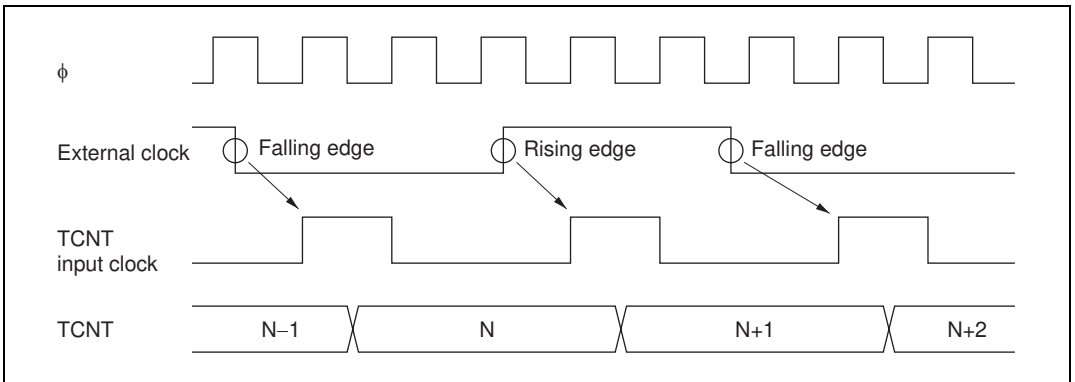

Figure 9.35 Count Timing in External Clock Operation

Output Compare Output Timing: A compare match signal is generated in the final state in which TCNT and TGR match (the point at which the count value matched by TCNT is updated). When a compare match signal is generated, the output value set in TIOR is output at the output compare output pin. After a match between TCNT and TGR, the compare match signal is not generated until the TCNT input clock is generated.

Figure 9.36 shows output compare output timing.

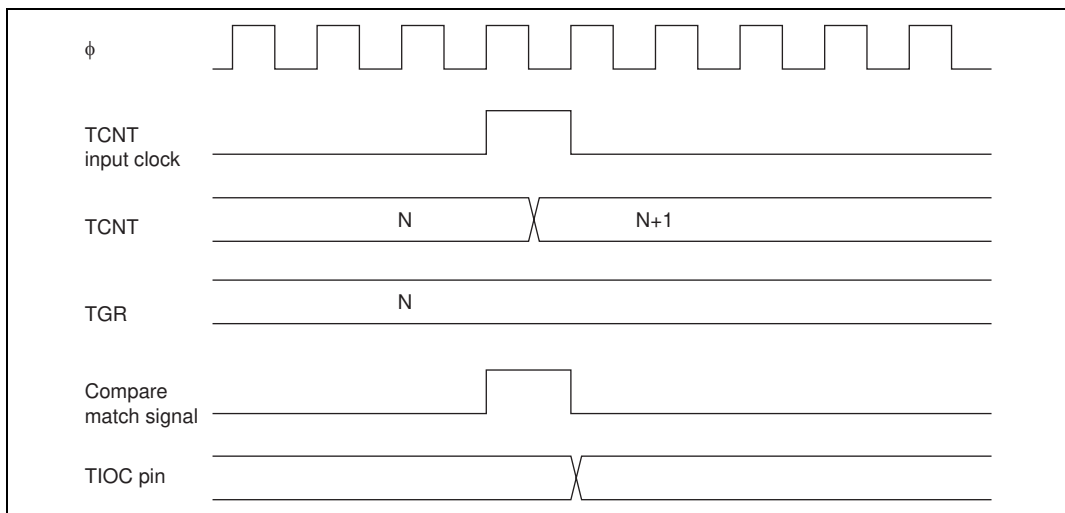

Figure 9.36 Output Compare Output Timing

Input Capture Signal Timing: Figure 9.37 shows input capture signal timing.

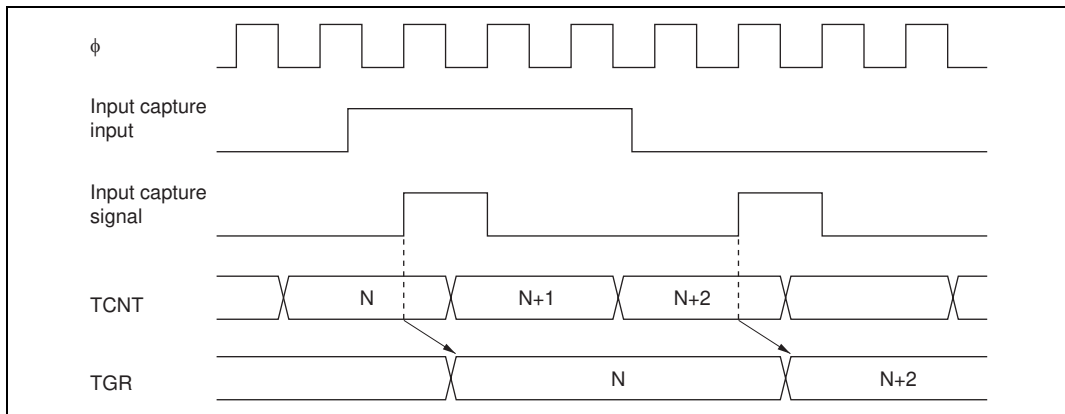

Figure 9.37 Input Capture Input Signal Timing

Timing for Counter Clearing by Compare Match/Input Capture: Figure 9.38 shows the timing when counter clearing by compare match occurrence is specified, and figure 9.39 shows the timing when counter clearing by input capture occurrence is specified.

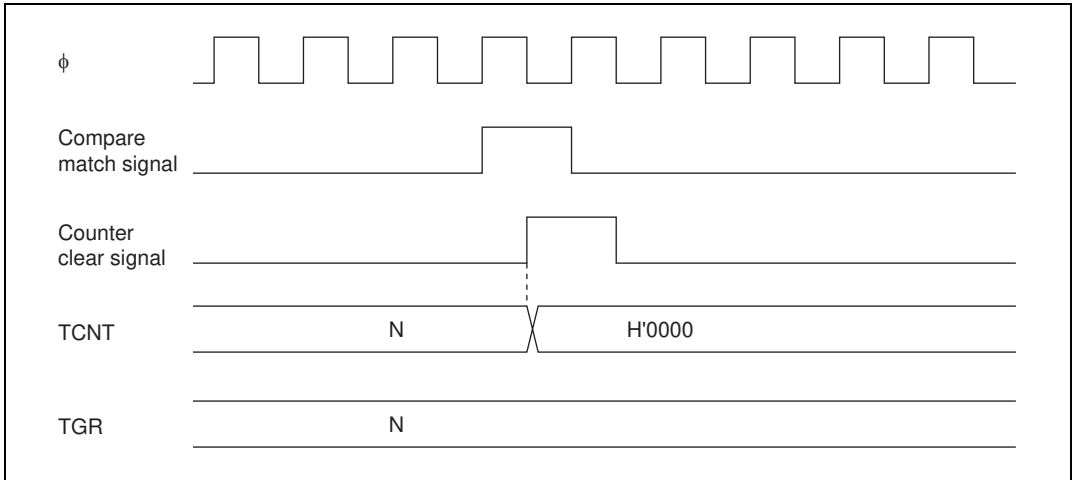

Figure 9.38 Counter Clear Timing (Compare Match)

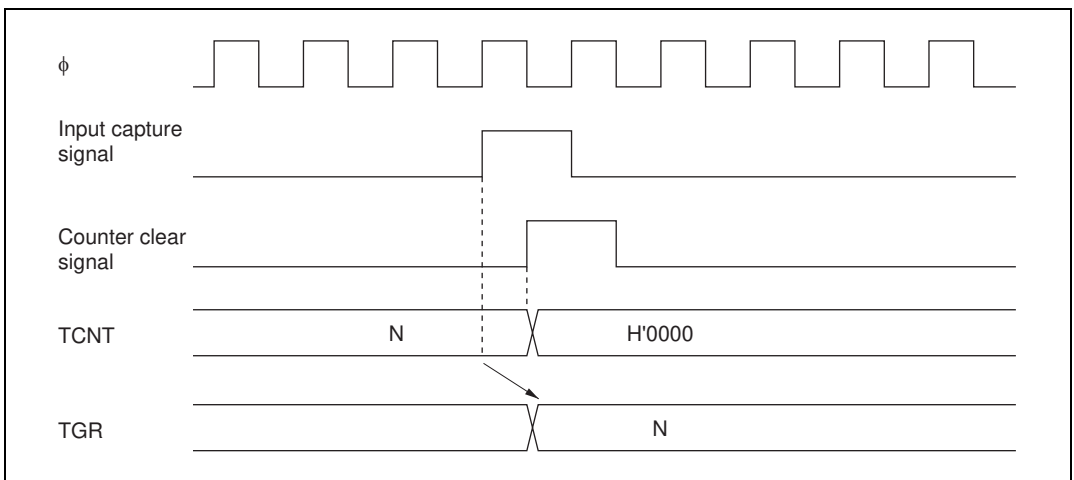

Figure 9.39 Counter Clear Timing (Input Capture)

Buffer Operation Timing: Figures 9.40 and 9.41 show the timing in buffer operation.

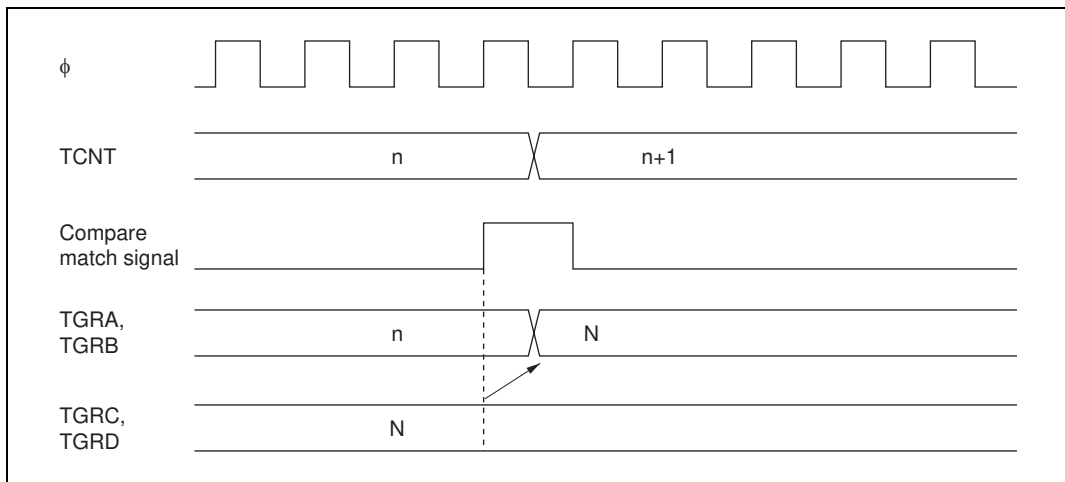

Figure 9.40 Buffer Operation Timing (Compare Match)

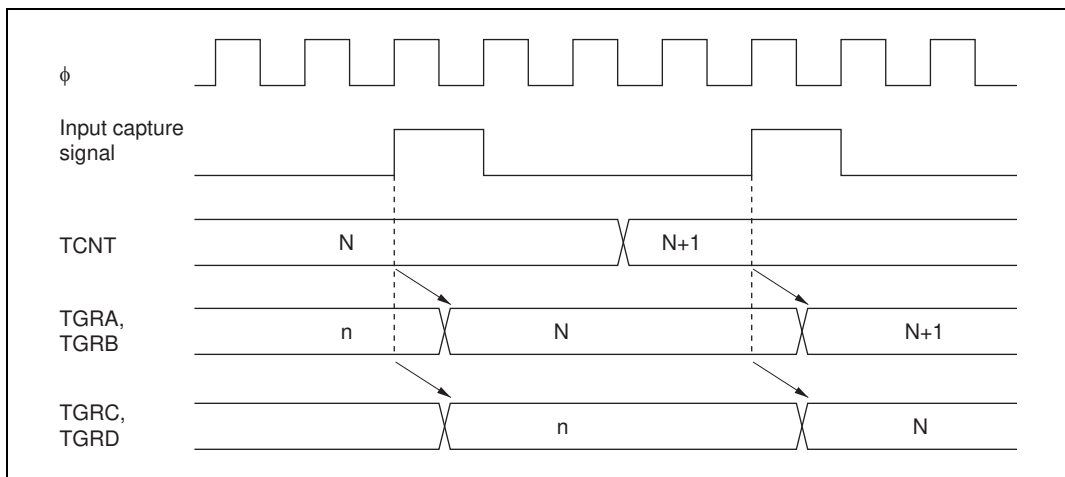

Figure 9.41 Buffer Operation Timing (Input Capture)

9.6.2 Interrupt Signal Timing

TGF Flag Setting Timing in Case of Compare Match: Figure 9.42 shows the timing for setting of the TGF flag in TSR by compare match occurrence, and TGI interrupt request signal timing.

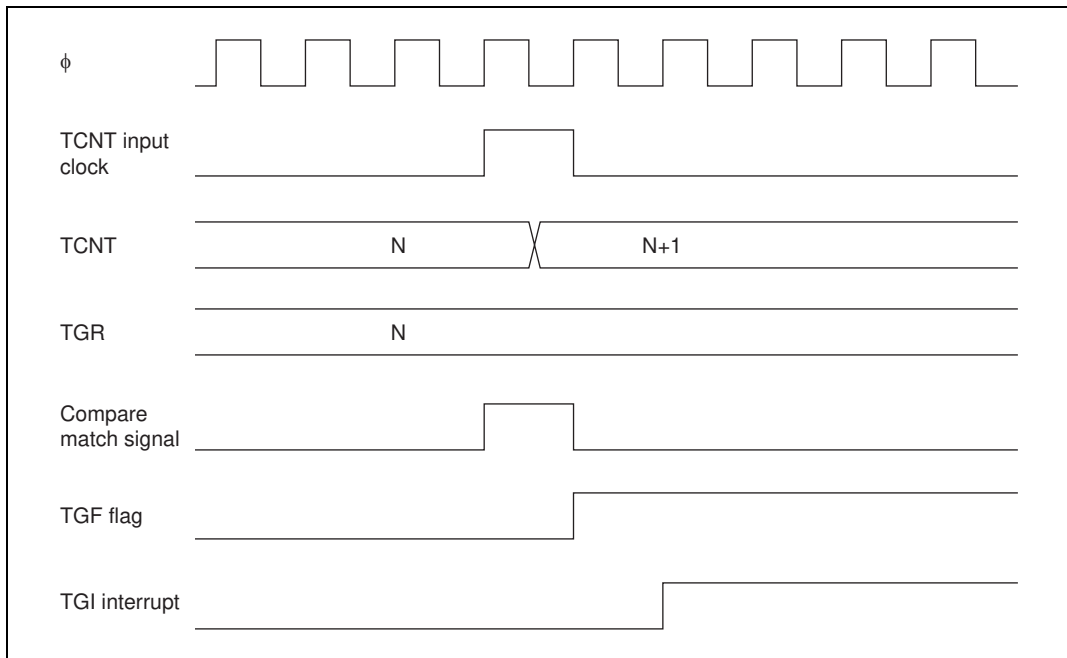

Figure 9.42 TGI Interrupt Timing (Compare Match)

TGF Flag Setting Timing in Case of Input Capture: Figure 9.43 shows the timing for setting of the TGF flag in TSR by input capture occurrence, and TGI interrupt request signal timing.

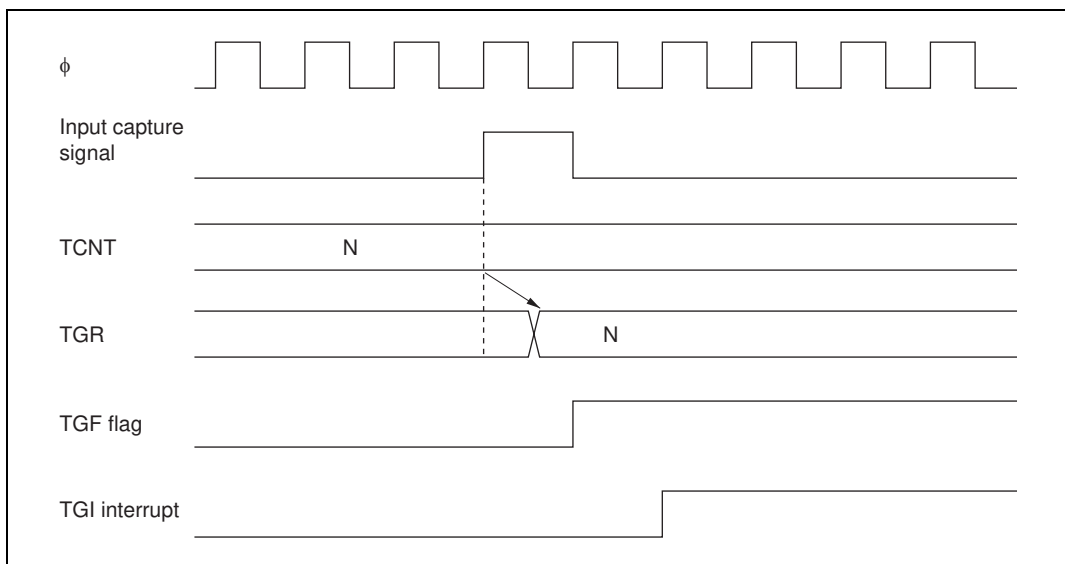

Figure 9.43 TGI Interrupt Timing (Input Capture)

TCFV Flag/TCFU Flag Setting Timing: Figure 9.44 shows the timing for setting of the TCFV flag in TSR by overflow occurrence, and TCIV interrupt request signal timing.

Figure 9.45 shows the timing for setting of the TCFU flag in TSR by underflow occurrence, and TCIU interrupt request signal timing.

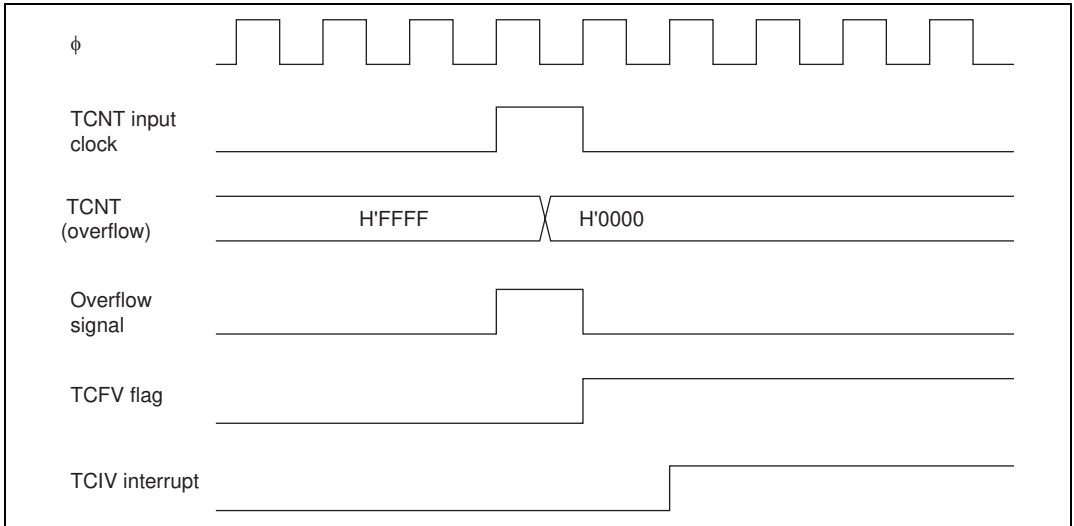

Figure 9.44 TCIV Interrupt Setting Timing

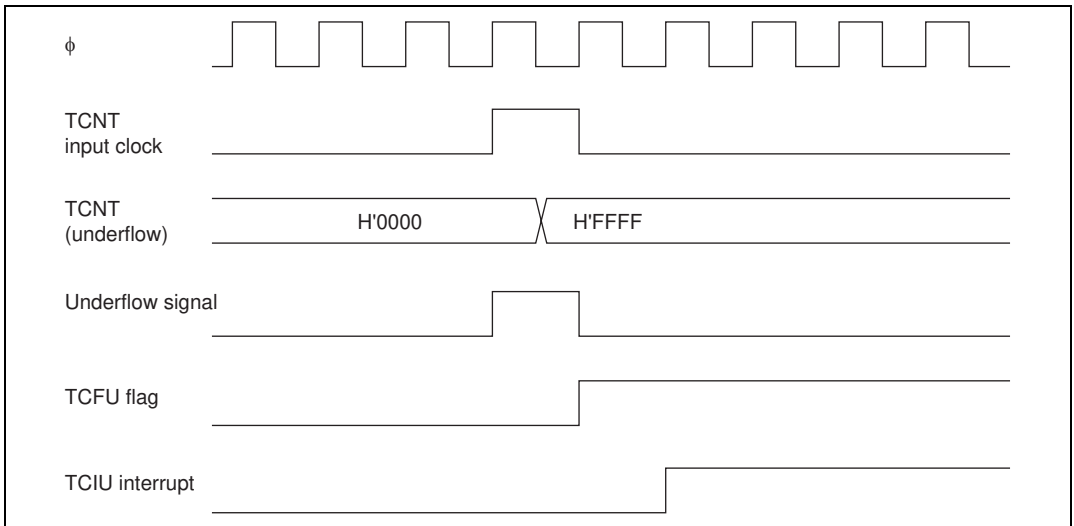

Figure 9.45 TCIU Interrupt Setting Timing

Status Flag Clearing Timing: After a status flag is read as 1 by the CPU, it is cleared by writing 0 to it. When the DTC is activated, the flag is cleared automatically. Figure 9.46 shows the timing for status flag clearing by the CPU, and figure 9.47 shows the timing for status flag clearing by the DTC.

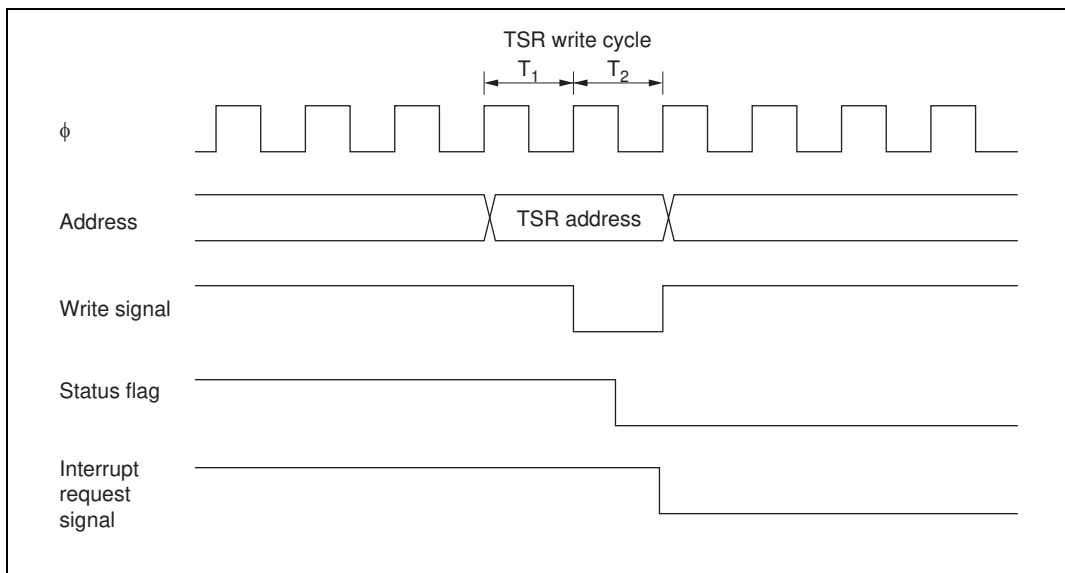

Figure 9.46 Timing for Status Flag Clearing by CPU

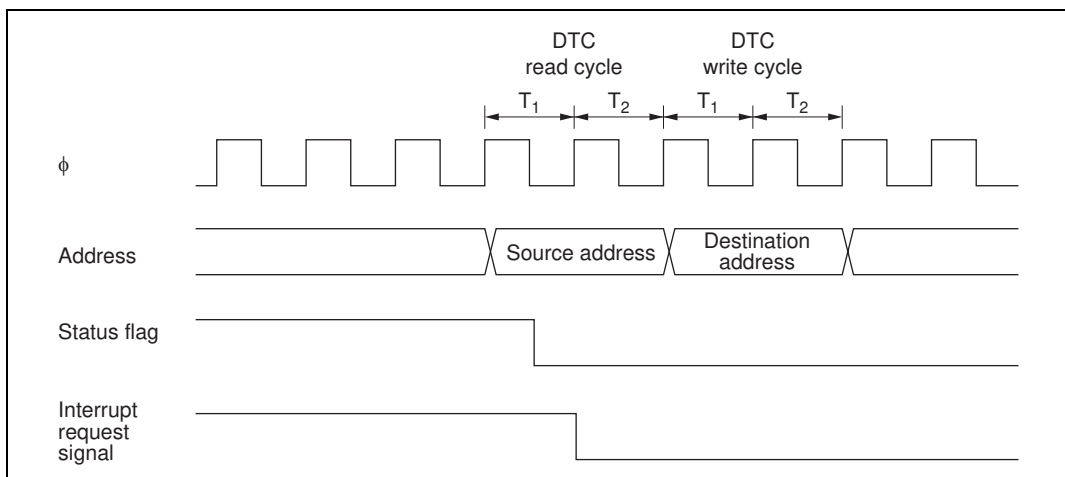

Figure 9.47 Timing for Status Flag Clearing by DTC Activation

9.7 Usage Notes

Note that the kinds of operation and contention described below can occur during TPU operation.

Input Clock Restrictions: The input clock pulse width must be at least 1.5 states in the case of single-edge detection, and at least 2.5 states in the case of both-edge detection. The TPU will not operate properly with a narrower pulse width.

In phase counting mode, the phase difference and overlap between the two input clocks must be at least 1.5 states, and the pulse width must be at least 2.5 states. Figure 9.48 shows the input clock conditions in phase counting mode.

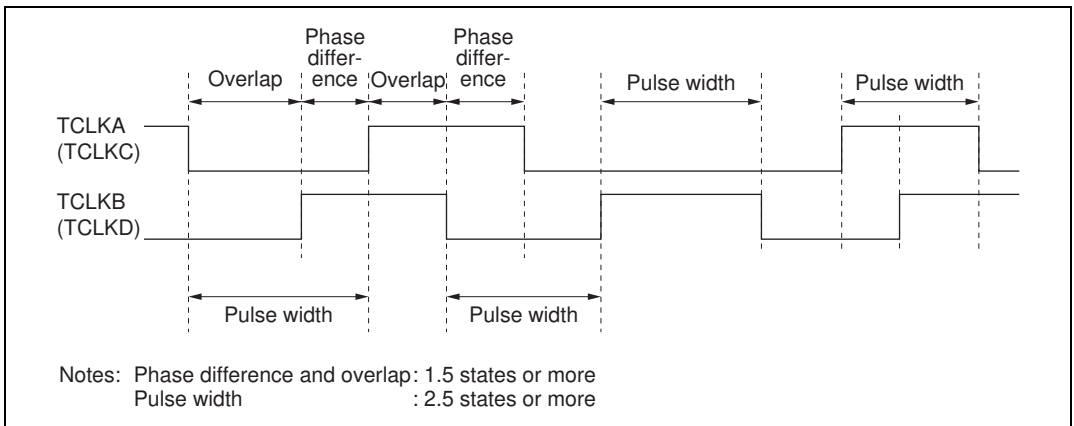

Figure 9.48 Phase Difference, Overlap, and Pulse Width in Phase Counting Mode

Caution on Period Setting: When counter clearing by compare match is set, TCNT is cleared in the final state in which it matches the TGR value (the point at which the count value matched by TCNT is updated). Consequently, the actual counter frequency is given by the following formula:

$$f = \frac{\phi}{(N + 1)}$$

Where f: Counter frequency
 ϕ : Operating frequency
 N: TGR set value

Contention between TCNT Write and Clear Operations: If the counter clear signal is generated in the T_2 state of a TCNT write cycle, TCNT clearing takes precedence and the TCNT write is not performed.

Figure 9.49 shows the timing in this case.

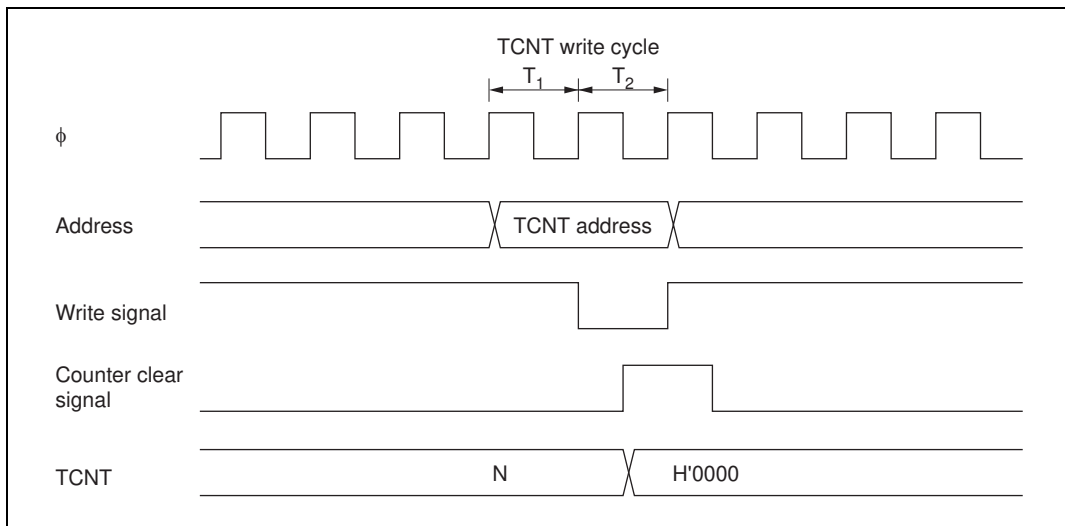

Figure 9.49 Contention between TCNT Write and Clear Operations

Contention between TCNT Write and Increment Operations: If incrementing occurs in the T_2 state of a TCNT write cycle, the TCNT write takes precedence and TCNT is not incremented.

Figure 9.50 shows the timing in this case.

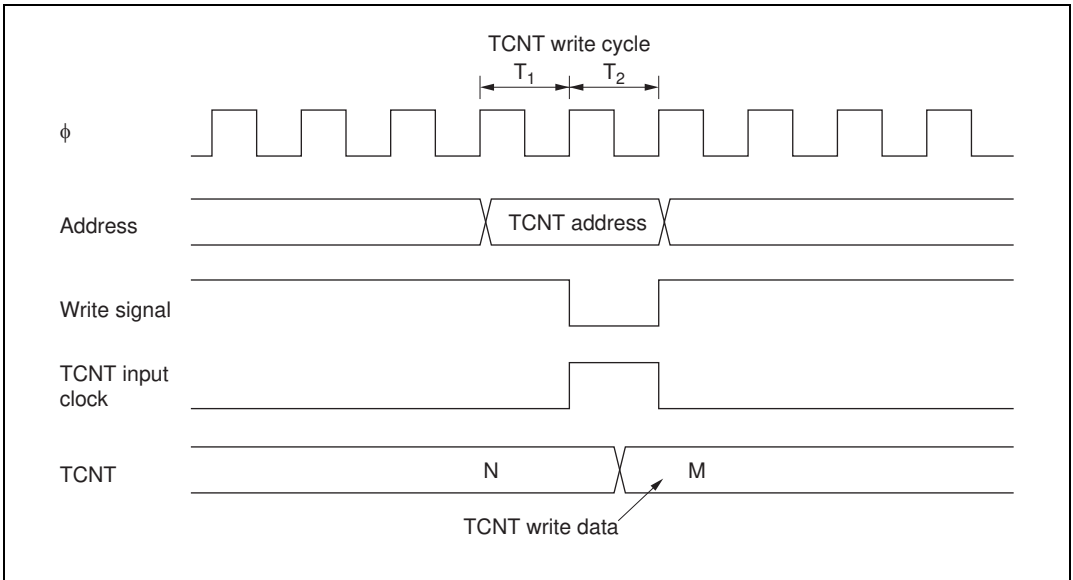

Figure 9.50 Contention between TCNT Write and Increment Operations

Contention between TGR Write and Compare Match: If a compare match occurs in the T_2 state of a TGR write cycle, the TGR write takes precedence and the compare match signal is inhibited. A compare match does not occur even if the same value as before is written.

Figure 9.51 shows the timing in this case.

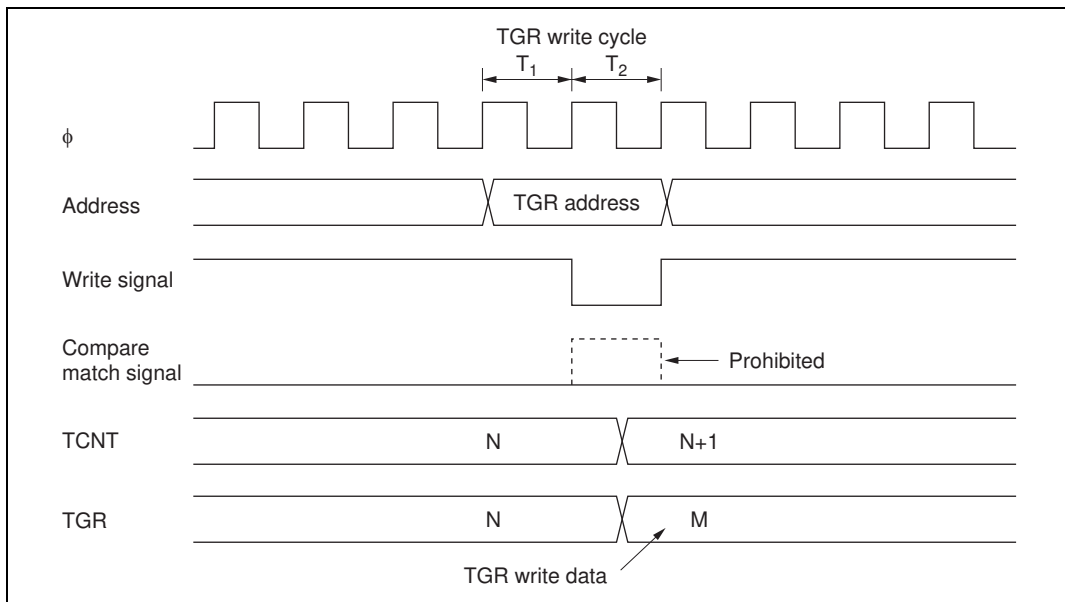

Figure 9.51 Contention between TGR Write and Compare Match

Contention between Buffer Register Write and Compare Match: If a compare match occurs in the T_2 state of a TGR write cycle, the data transferred to TGR by the buffer operation will be the data prior to the write.

Figure 9.52 shows the timing in this case.

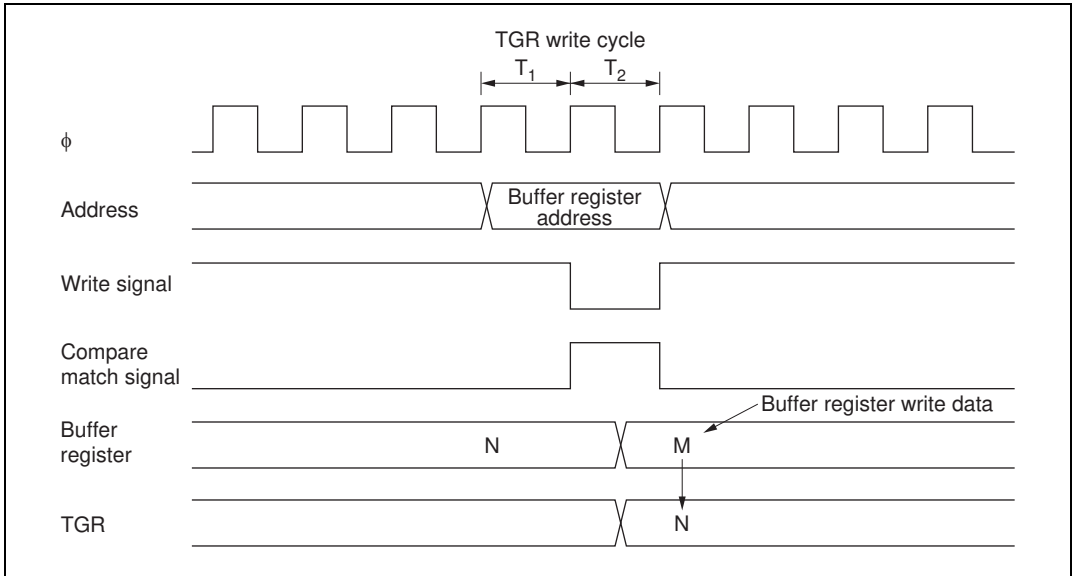

Figure 9.52 Contention between Buffer Register Write and Compare Match

Contention between TGR Read and Input Capture: If the input capture signal is generated in the T_1 state of a TGR read cycle, the data that is read will be the data after input capture transfer.

Figure 9.53 shows the timing in this case.

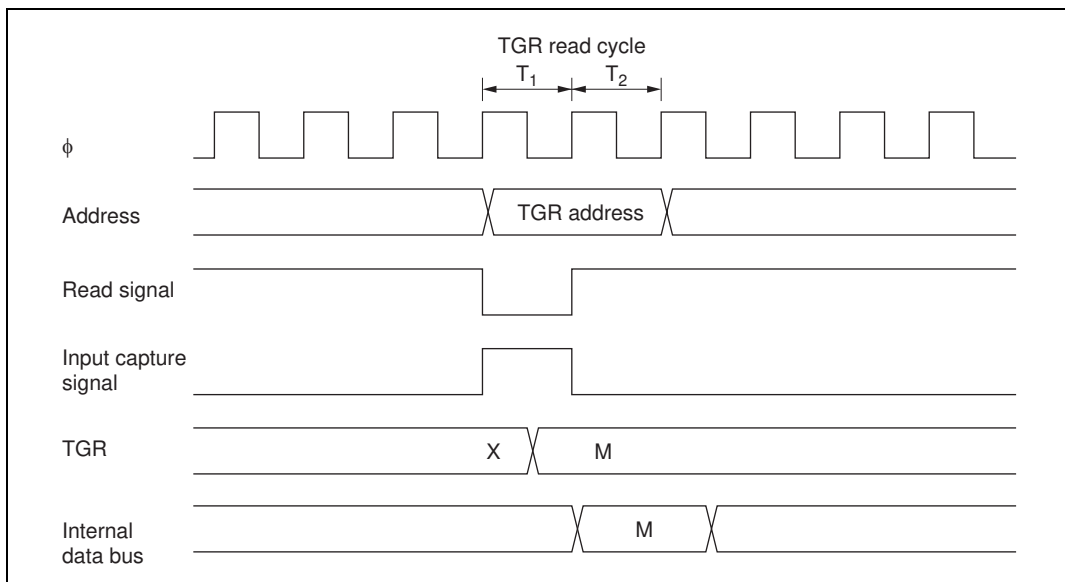

Figure 9.53 Contention between TGR Read and Input Capture

Contention between TGR Write and Input Capture: If the input capture signal is generated in the T_2 state of a TGR write cycle, the input capture operation takes precedence and the write to TGR is not performed.

Figure 9.54 shows the timing in this case.

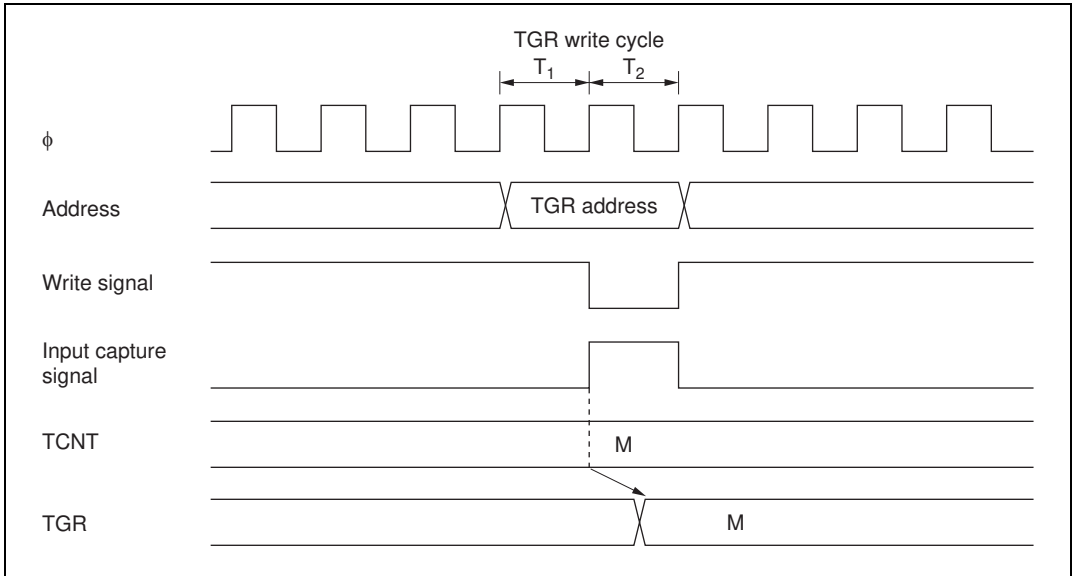

Figure 9.54 Contention between TGR Write and Input Capture

Contention between Buffer Register Write and Input Capture: If the input capture signal is generated in the T_2 state of a buffer write cycle, the buffer operation takes precedence and the write to the buffer register is not performed.

Figure 9.55 shows the timing in this case.

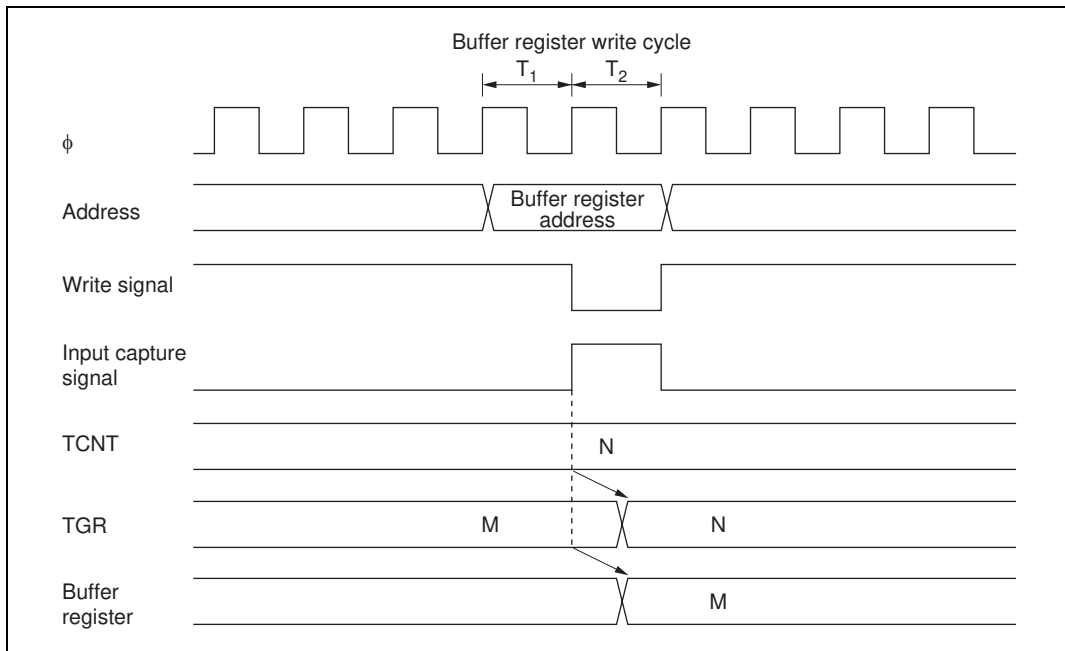

Figure 9.55 Contention between Buffer Register Write and Input Capture

Contention between Overflow/Underflow and Counter Clearing: If overflow/underflow and counter clearing occur simultaneously, the TCFV/TCFU flag in TSR is not set and TCNT clearing takes precedence.

Figure 9.56 shows the operation timing when a TGR compare match is specified as the clearing source, and H'FFFF is set in TGR.

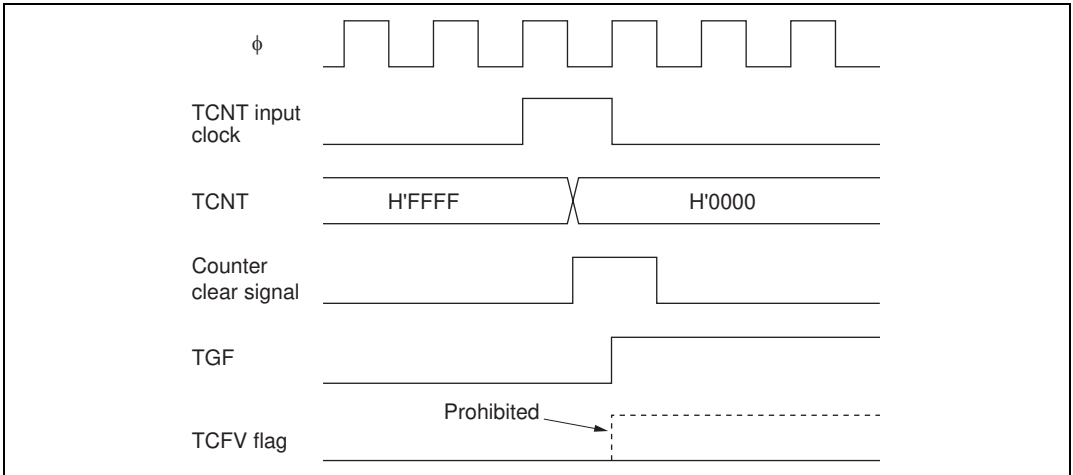

Figure 9.56 Contention between Overflow and Counter Clearing

Contention between TCNT Write and Overflow/Underflow: If there is an up-count or down-count in the T_2 state of a TCNT write cycle, and overflow/underflow occurs, the TCNT write takes precedence and the TCFV/TCFU flag in TSR is not set.

Figure 9.57 shows the operation timing when there is contention between TCNT write and overflow.

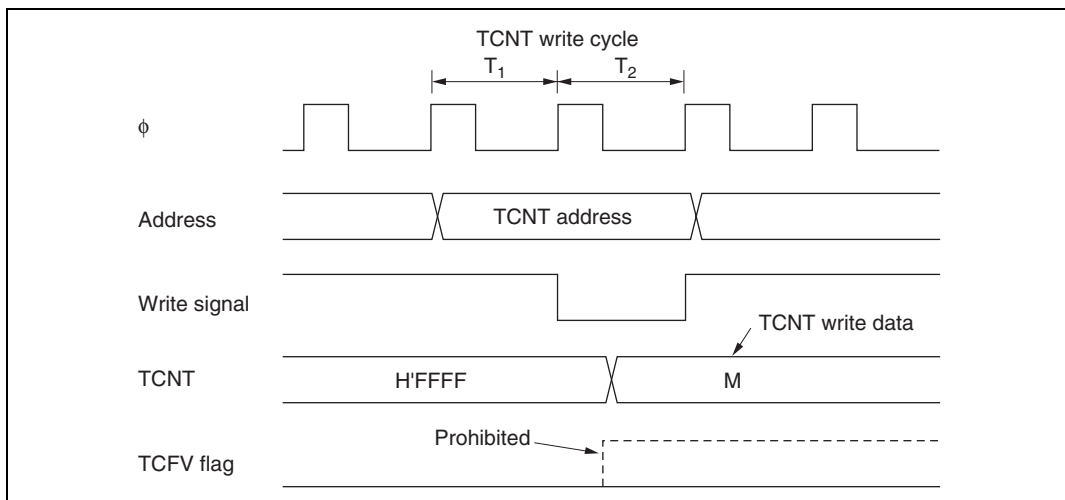

Figure 9.57 Contention between TCNT Write and Overflow

Multiplexing of I/O Pins: In the chip, the TCLKA input pin is multiplexed with the TIOCC0 I/O pin, the TCLKB input pin with the TIOCD0 I/O pin, the TCLKC input pin with the TIOCB1 I/O pin, and the TCLKD input pin with the TIOCB2 I/O pin. When an external clock is input, compare match output should not be performed from a multiplexed pin.

Interrupts and Module Stop Mode: If module stop mode is entered when an interrupt has been requested, it will not be possible to clear the CPU interrupt source or DTC activation source. Interrupts should therefore be disabled before entering module stop mode.

Section 10 8-Bit Timers

10.1 Overview

The chip includes an 8-bit timer module with two channels (TMR0 and TMR1). Each channel has an 8-bit counter (TCNT) and two time constant registers (TCORA and TCORB) that are constantly compared with the TCNT value to detect compare match events. The 8-bit timer module can thus be used for a variety of functions, including pulse output with an arbitrary duty cycle.

10.1.1 Features

The features of the 8-bit timer module are listed below.

- Selection of four clock sources
The counters can be driven by one of three internal clock signals ($\phi/8$, $\phi/64$, or $\phi/8192$) or an external clock input (enabling use as an external event counter)
- Selection of three ways to clear the counters
The counters can be cleared on compare match A or B, or by an external reset signal
- Timer output control by a combination of two compare match signals
The timer output signal in each channel is controlled by a combination of two independent compare match signals, enabling the timer to generate output waveforms with an arbitrary duty cycle or PWM output
- Provision for cascading of two channels
 - Operation as a 16-bit timer is possible, using channel 0 for the upper 8 bits and channel 1 for the lower 8 bits (16-bit count mode)
 - Channel 1 can be used to count channel 0 compare matches (compare match count mode)
- Three independent interrupts
Compare match A and B and overflow interrupts can be requested independently
- A/D converter conversion start trigger can be generated
Channel 0 compare match A signal can be used as an A/D converter conversion start trigger
- Module stop mode can be set
As the initial setting, 8-bit timer operation is halted. Register access is enabled by exiting module stop mode

10.1.2 Block Diagram

Figure 10.1 shows a block diagram of the 8-bit timer module.

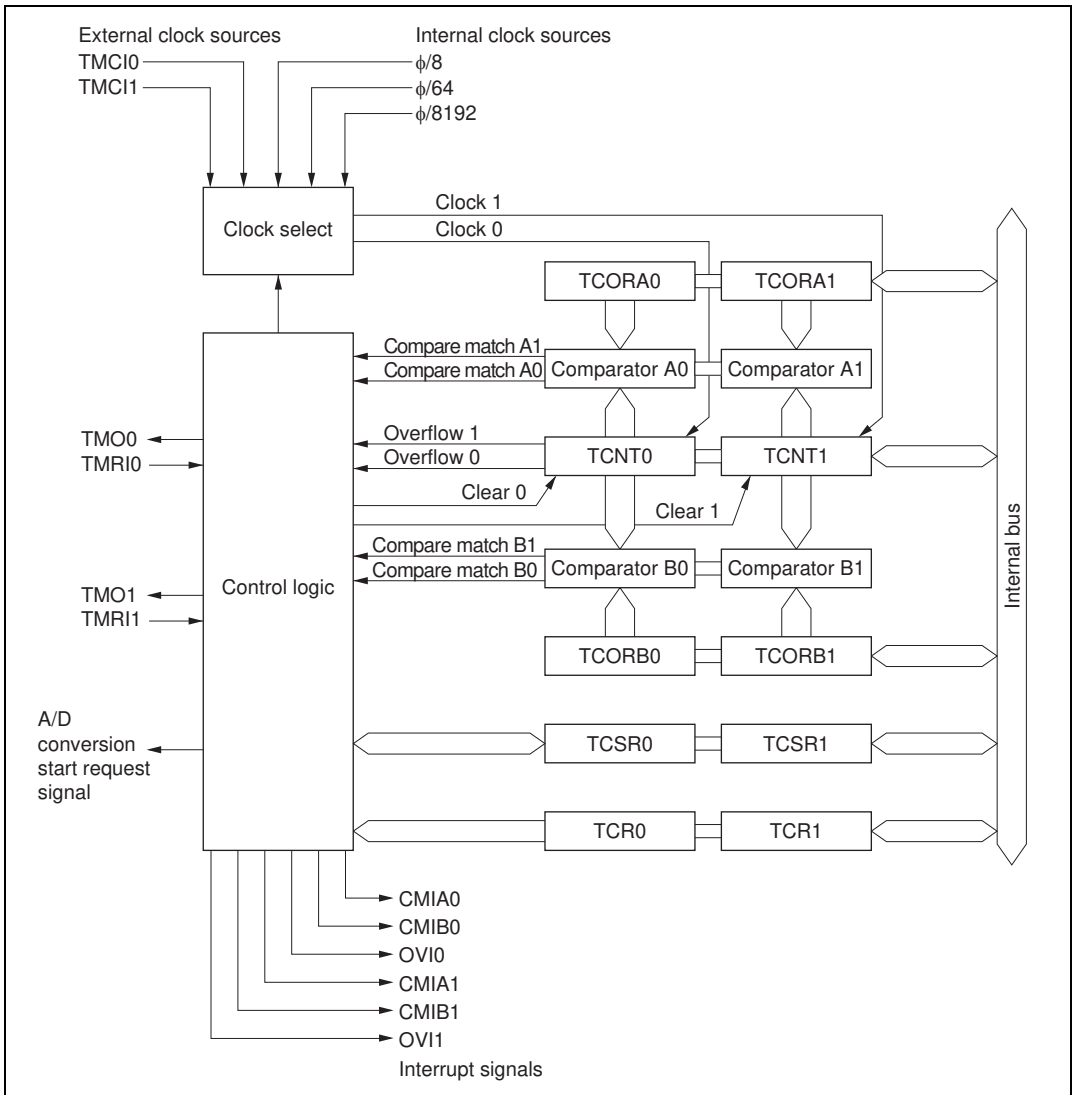

Figure 10.1 Block Diagram of 8-Bit Timer Module

10.1.3 Pin Configuration

Table 10.1 summarizes the input and output pins of the 8-bit timer module.

Table 10.1 Input and Output Pins of 8-Bit Timer

Channel	Name	Symbol	I/O	Function
0	Timer output pin 0	TMO0	Output	Outputs at compare match
	Timer clock input pin 0	TMCi0	Input	Inputs external clock for counter
	Timer reset input pin 0	TMRi0	Input	Inputs external reset to counter
1	Timer output pin 1	TMO1	Output	Outputs at compare match
	Timer clock input pin 1	TMCi1	Input	Inputs external clock for counter
	Timer reset input pin 1	TMRi1	Input	Inputs external reset to counter

10.1.4 Register Configuration

Table 10.2 summarizes the registers of the 8-bit timer module.

Table 10.2 8-Bit Timer Registers

Channel	Name	Abbreviation	R/W	Initial value	Address*1
0	Timer control register 0	TCR0	R/W	H'00	H'FFB0
	Timer control/status register 0	TCSR0	R/(W)*2	H'00	H'FFB2
	Time constant register A0	TCORA0	R/W	H'FF	H'FFB4
	Time constant register B0	TCORB0	R/W	H'FF	H'FFB6
	Timer counter 0	TCNT0	R/W	H'00	H'FFB8
1	Timer control register 1	TCR1	R/W	H'00	H'FFB1
	Timer control/status register 1	TCSR1	R/(W)*2	H'10	H'FFB3
	Time constant register A1	TCORA1	R/W	H'FF	H'FFB5
	Time constant register B1	TCORB1	R/W	H'FF	H'FFB7
	Timer counter 1	TCNT1	R/W	H'00	H'FFB9
All	Module stop control register	MSTPCR	R/W	H'3FFF	H'FF3C

Notes: 1. Lower 16 bits of the address

2. Only 0 can be written to bits 7 to 5, to clear these flags.

Each pair of registers for channel 0 and channel 1 is a 16-bit register with the upper 8 bits for channel 0 and the lower 8 bits for channel 1, so they can be accessed together by a word transfer instruction.

10.2 Register Descriptions

10.2.1 Timer Counters 0 and 1 (TCNT0, TCNT1)

	TCNT0								TCNT1							
Bit	15	14	13	12	11	10	9	8	7	6	5	4	3	2	1	0
Initial value :	0	0	0	0	0	0	0	0	0	0	0	0	0	0	0	0
R/W	R/W	R/W	R/W	R/W	R/W	R/W	R/W	R/W	R/W	R/W	R/W	R/W	R/W	R/W	R/W	R/W

TCNT0 and TCNT1 are 8-bit readable/writable up-counters that increment on pulses generated from an internal or external clock source. This clock source is selected by clock select bits CKS2 to CKS0 in TCR. The CPU can read or write to TCNT0 and TCNT1 at all times.

TCNT0 and TCNT1 comprise a single 16-bit register, so they can be accessed together by a word transfer instruction.

TCNT0 and TCNT1 can be cleared by an external reset input or by a compare match signal. Which signal is to be used for clearing is selected by clock clear bits CCLR1 and CCLR0 in TCR.

When a timer counter overflows from H'FF to H'00, OVF in TCSR is set to 1.

TCNT0 and TCNT1 are each initialized to H'00 by a reset and in hardware standby mode.

10.2.2 Time Constant Registers A0 and A1 (TCORA0, TCORA1)

	TCORA0								TCORA1							
Bit	15	14	13	12	11	10	9	8	7	6	5	4	3	2	1	0
Initial value :	1	1	1	1	1	1	1	1	1	1	1	1	1	1	1	1
R/W	R/W	R/W	R/W	R/W	R/W	R/W	R/W	R/W	R/W	R/W	R/W	R/W	R/W	R/W	R/W	R/W

TCORA0 and TCORA1 are 8-bit readable/writable registers. TCORA0 and TCORA1 comprise a single 16-bit register so they can be accessed together by a word transfer instruction.

TCORA is continually compared with the value in TCNT. When a match is detected, the corresponding CMFA flag in TCSR is set. Note, however, that comparison is disabled during the T₂ state of a TCOR write cycle.

The timer output can be freely controlled by these compare match signals and the settings of bits OS1 and OS0 in TCSR.

TCORA0 and TCORA1 are each initialized to H'FF by a reset and in hardware standby mode.

10.2.3 Time Constant Registers B0 and B1 (TCORB0, TCORB1)

	TCORB0								TCORB1							
Bit	15	14	13	12	11	10	9	8	7	6	5	4	3	2	1	0
Initial value :	1	1	1	1	1	1	1	1	1	1	1	1	1	1	1	1
R/W	R/W	R/W	R/W	R/W	R/W	R/W	R/W	R/W	R/W	R/W	R/W	R/W	R/W	R/W	R/W	R/W

TCORB0 and TCORB1 are 8-bit readable/writable registers. TCORB0 and TCORB1 comprise a single 16-bit register so they can be accessed together by a word transfer instruction.

TCORB is continually compared with the value in TCNT. When a match is detected, the corresponding CMFB flag in TCSR is set. Note, however, that comparison is disabled during the T₂ state of a TCOR write cycle.

The timer output can be freely controlled by these compare match signals and the settings of output select bits OS3 and OS2 in TCSR.

TCORB0 and TCORB1 are each initialized to H'FF by a reset and in hardware standby mode.

10.2.4 Time Control Registers 0 and 1 (TCR0, TCR1)

	7	6	5	4	3	2	1	0
Bit	CMIEB	CMIEA	OVIE	CCLR1	CCLR0	CKS2	CKS1	CKS0
Initial value :	0	0	0	0	0	0	0	0
R/W	R/W	R/W	R/W	R/W	R/W	R/W	R/W	R/W

TCR0 and TCR1 are 8-bit readable/writable registers that select the clock source and the time at which TCNT is cleared, and enable interrupts.

TCR0 and TCR1 are each initialized to H'00 by a reset and in hardware standby mode.

For details of this timing, see section 10.3, Operation.

Bit 7—Compare Match Interrupt Enable B (CMIEB): Selects whether CMFB interrupt requests (CMIB) are enabled or disabled when the CMFB flag in TCSR is set to 1.

Bit 7

CMIEB	Description
0	CMFB interrupt requests (CMIB) are disabled (Initial value)
1	CMFB interrupt requests (CMIB) are enabled

Bit 6—Compare Match Interrupt Enable A (CMIEA): Selects whether CMFA interrupt requests (CMIA) are enabled or disabled when the CMFA flag in TCSR is set to 1.

Bit 6

CMIEA	Description
0	CMFA interrupt requests (CMIA) are disabled (Initial value)
1	CMFA interrupt requests (CMIA) are enabled

Bit 5—Timer Overflow Interrupt Enable (OVIE): Selects whether OVF interrupt requests (OVI) are enabled or disabled when the OVF flag in TCSR is set to 1.

Bit 5

OVIE	Description
0	OVF interrupt requests (OVI) are disabled (Initial value)
1	OVF interrupt requests (OVI) are enabled

Bits 4 and 3—Counter Clear 1 and 0 (CCLR1 and CCLR0): These bits select the method by which TCNT is cleared: by compare match A or B, or by an external reset input.

Bit 4 CCLR1	Bit 3 CCLR0	Description
0	0	Clearing is disabled (Initial value)
	1	Clear by compare match A
1	0	Clear by compare match B
	1	Clear by rising edge of external reset input

Bits 2 to 0—Clock Select 2 to 0 (CKS2 to CKS0): These bits select whether the clock input to TCNT is an internal or external clock.

Three internal clocks can be selected, all divided from the system clock (ϕ): $\phi/8$, $\phi/64$, and $\phi/8192$. The falling edge of the selected internal clock triggers the count.

When use of an external clock is selected, three types of count can be selected: at the rising edge, the falling edge, and both rising and falling edges.

Some functions differ between channel 0 and channel 1.

Bit 2 CKS2	Bit 1 CKS1	Bit 0 CKS0	Description
0	0	0	Clock input disabled (Initial value)
		1	Internal clock, counted at falling edge of $\phi/8$
	1	0	Internal clock, counted at falling edge of $\phi/64$
		1	Internal clock, counted at falling edge of $\phi/8192$
1	0	0	For channel 0: count at TCNT1 overflow signal* For channel 1: count at TCNT0 compare match A*
		1	External clock, counted at rising edge
	1	0	External clock, counted at falling edge
		1	External clock, counted at both rising and falling edges

Note: * If the count input of channel 0 is the TCNT1 overflow signal and that of channel 1 is the TCNT0 compare match signal, no incrementing clock is generated. Do not use this setting.

10.2.5 Timer Control/Status Registers 0 and 1 (TCSR0, TCSR1)

TCSR0

Bit	:	7	6	5	4	3	2	1	0
		CMFB	CMFA	OVF	ADTE	OS3	OS2	OS1	OS0
Initial value	:	0	0	0	0	0	0	0	0
R/W	:	R/(W)*	R/(W)*	R/(W)*	R/W	R/W	R/W	R/W	R/W

TCSR1

Bit	:	7	6	5	4	3	2	1	0
		CMFB	CMFA	OVF	—	OS3	OS2	OS1	OS0
Initial value	:	0	0	0	1	0	0	0	0
R/W	:	R/(W)*	R/(W)*	R/(W)*	—	R/W	R/W	R/W	R/W

Note: * Only 0 can be written to bits 7 to 5, to clear these flags.

TCSR0 and TCSR1 are 8-bit registers that display compare match and overflow statuses, and control compare match output.

TCSR0 is initialized to H'00, and TCSR1 to H'10, by a reset and in hardware standby mode.

Bit 7—Compare Match Flag B (CMFB): Status flag indicating whether the values of TCNT and TCORB match.

Bit 7 CMFB	Description
0	[Clearing conditions] (Initial value) <ul style="list-style-type: none">• Cleared by reading CMFB when CMFB = 1, then writing 0 to CMFB• When DTC is activated by CMIB interrupt while DISEL bit of MRB in DTC is 0
1	[Setting condition] Set when TCNT matches TCORB

Bit 6—Compare Match Flag A (CMFA): Status flag indicating whether the values of TCNT and TCORA match.

Bit 6 CMFA	Description
0	[Clearing conditions] (Initial value) <ul style="list-style-type: none">• Cleared by reading CMFA when CMFA = 1, then writing 0 to CMFA• When DTC is activated by CMIA interrupt while DISEL bit of MRB in DTC is 0
1	[Setting condition] Set when TCNT matches TCORA

Bit 5—Timer Overflow Flag (OVF): Status flag indicating that TCNT has overflowed (changed from H'FF to H'00).

Bit 5 OVF	Description
0	[Clearing condition] (Initial value) Cleared by reading OVF when OVF = 1, then writing 0 to OVF
1	[Setting condition] Set when TCNT overflows from H'FF to H'00

Bit 4—A/D Trigger Enable (ADTE) (TCSR0 Only): Selects enabling or disabling of A/D converter start requests by compare match A.

In TCSR1, this bit is reserved: it is always read as 1 and cannot be modified.

Bit 4

ADTE	Description
0	A/D converter start requests by compare match A are disabled (Initial value)
1	A/D converter start requests by compare match A are enabled

Bits 3 to 0—Output Select 3 to 0 (OS3 to OS0): These bits specify how the timer output level is to be changed by a compare match of TCOR and TCNT.

Bits OS3 and OS2 select the effect of compare match B on the output level, bits OS1 and OS0 select the effect of compare match A on the output level, and both of them can be controlled independently.

Note, however, that priorities are set such that: toggle output > 1 output > 0 output. If compare matches occur simultaneously, the output changes according to the compare match with the higher priority.

Timer output is disabled when bits OS3 to OS0 are all 0.

After a reset, the timer output is 0 until the first compare match event occurs.

Bit 3 OS3	Bit 2 OS2	Description
0	0	No change when compare match B occurs (Initial value)
	1	0 is output when compare match B occurs
1	0	1 is output when compare match B occurs
	1	Output is inverted when compare match B occurs (toggle output)

Bit 1 OS1	Bit 0 OS0	Description
0	0	No change when compare match A occurs (Initial value)
	1	0 is output when compare match A occurs
1	0	1 is output when compare match A occurs
	1	Output is inverted when compare match A occurs (toggle output)

10.2.6 Module Stop Control Register (MSTPCR)

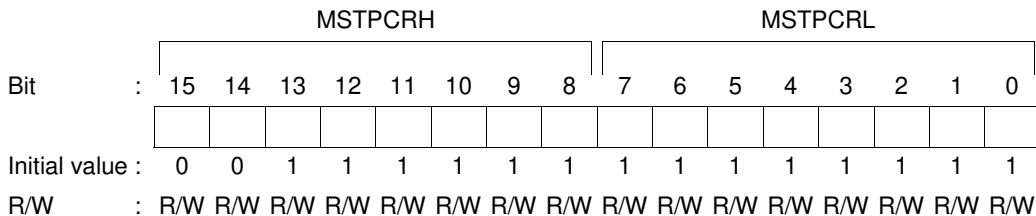

MSTPCR is a 16-bit readable/writable register that performs module stop mode control.

When the MSTP12 bit in MSTPCR is set to 1, the 8-bit timer operation stops at the end of the bus cycle and a transition is made to module stop mode. Registers cannot be read or written to in module stop mode. For details, see section 19.5, Module Stop Mode.

MSTPCR is initialized to H'3FFF by a reset and in hardware standby mode. It is not initialized in software standby mode.

Bit 12—Module Stop (MSTP12): Specifies the 8-bit timer module stop mode.

Bit 12

MSTP12	Description
0	8-bit timer module stop mode cleared
1	8-bit timer module stop mode set (Initial value)

10.3 Operation

10.3.1 TCNT Incrementation Timing

TCNT is incremented by input clock pulses (either internal or external).

Internal Clock: Three different internal clock signals ($\phi/8$, $\phi/64$, or $\phi/8192$) divided from the system clock (ϕ) can be selected, by setting bits CKS2 to CKS0 in TCR. Figure 10.2 shows the count timing.

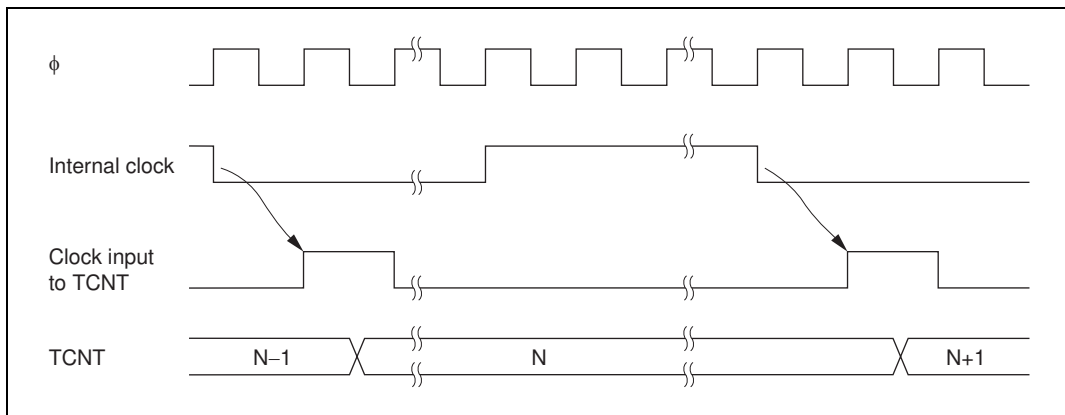

Figure 10.2 Count Timing for Internal Clock Input

External Clock: Three incrementation methods can be selected by setting bits CKS2 to CKS0 in TCR: at the rising edge, the falling edge, and both rising and falling edges.

Note that the external clock pulse width must be at least 1.5 states for incrementation at a single edge, and at least 2.5 states for incrementation at both edges. The counter will not increment correctly if the pulse width is less than these values.

Figure 10.3 shows the timing of incrementation at both edges of an external clock signal.

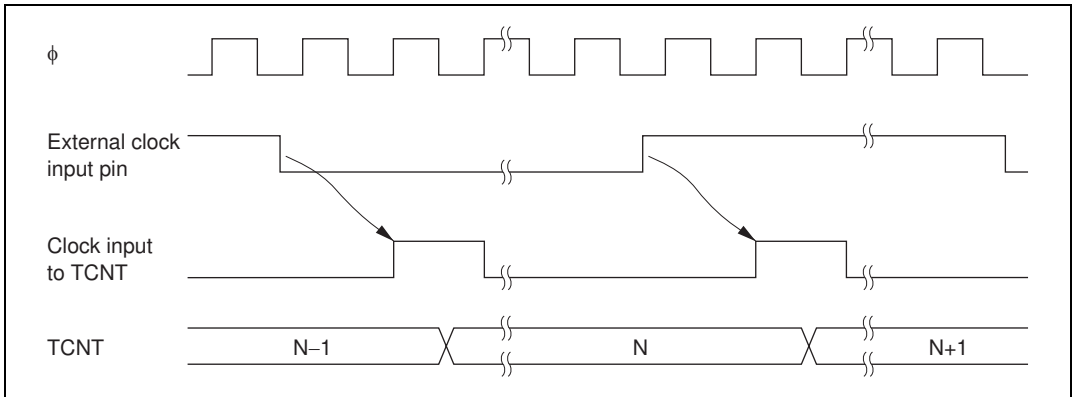

Figure 10.3 Count Timing for External Clock Input

10.3.2 Compare Match Timing

Setting of Compare Match Flags A and B (CMFA, CMFB): The CMFA and CMFB flags in TCSR are set to 1 by a compare match signal generated when the TCOR and TCNT values match. The compare match signal is generated at the last state in which the match is true, just before the timer counter is updated.

Therefore, when TCOR and TCNT match, the compare match signal is not generated until the next incrementation clock input. Figure 10.4 shows this timing.

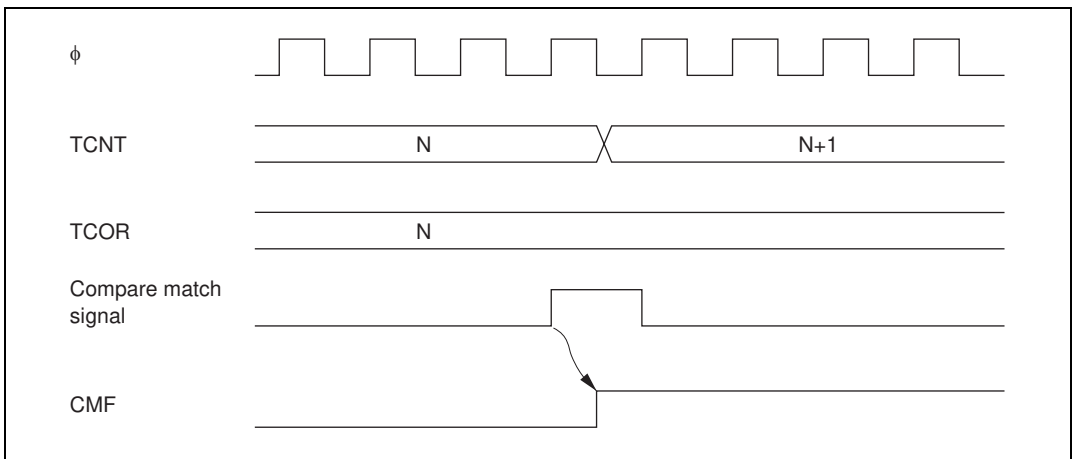

Figure 10.4 Timing of CMF Setting

Timer Output Timing: When compare match A or B occurs, the timer output changes as specified by bits OS3 to OS0 in TCSR. Depending on these bits, the output can remain the same, change to 0, change to 1, or toggle.

Figure 10.5 shows the timing when the output is set to toggle at compare match A.

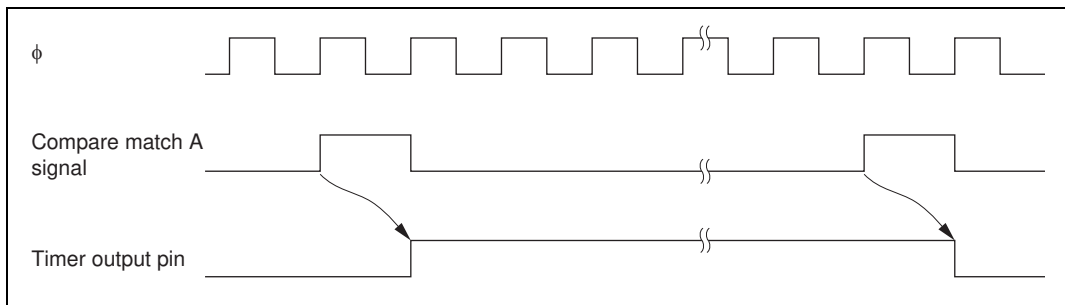

Figure 10.5 Timing of Timer Output

Timing of Compare Match Clear: The timer counter is cleared when compare match A or B occurs, depending on the setting of the CCLR1 and CCLR0 bits in TCR. Figure 10.6 shows the timing of this operation.

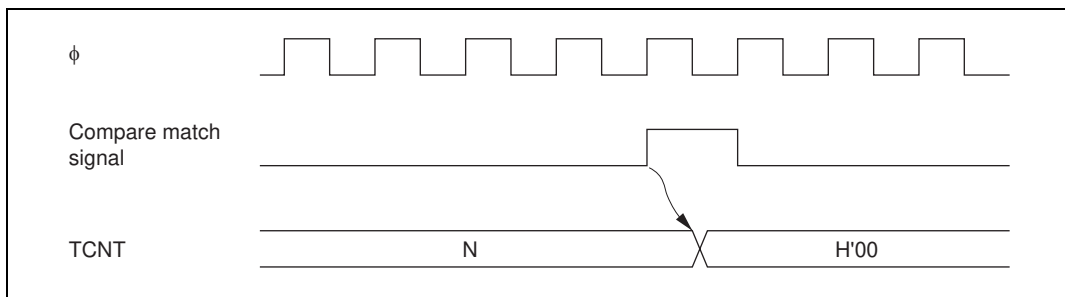

Figure 10.6 Timing of Compare Match Clear

10.3.3 Timing of TCNT External Reset

TCNT is cleared at the rising edge of an external reset input, depending on the settings of the CCLR1 and CCLR0 bits in TCR. The clear pulse width must be at least 1.5 states. Figure 10.7 shows the timing of this operation.

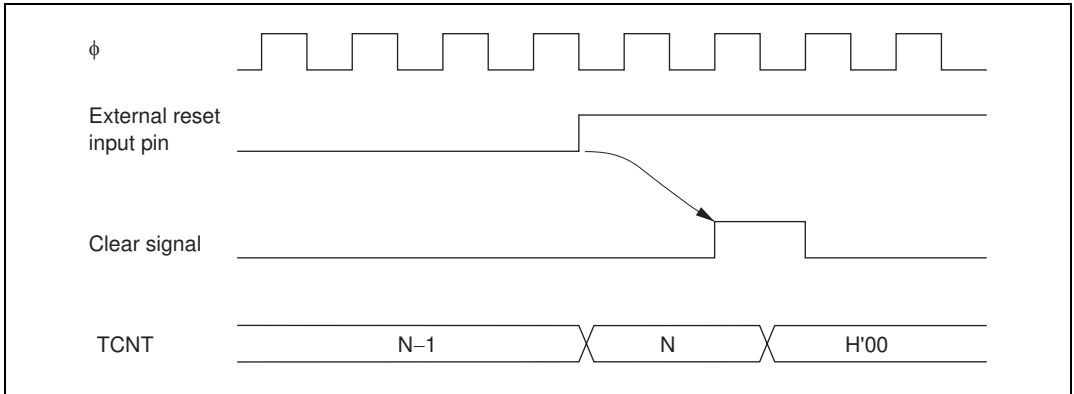

Figure 10.7 Timing of Clearance by External Reset

10.3.4 Timing of Overflow Flag (OVF) Setting

The OVF in TCSR is set to 1 when TCNT overflows (changes from H'FF to H'00). Figure 10.8 shows the timing of this operation.

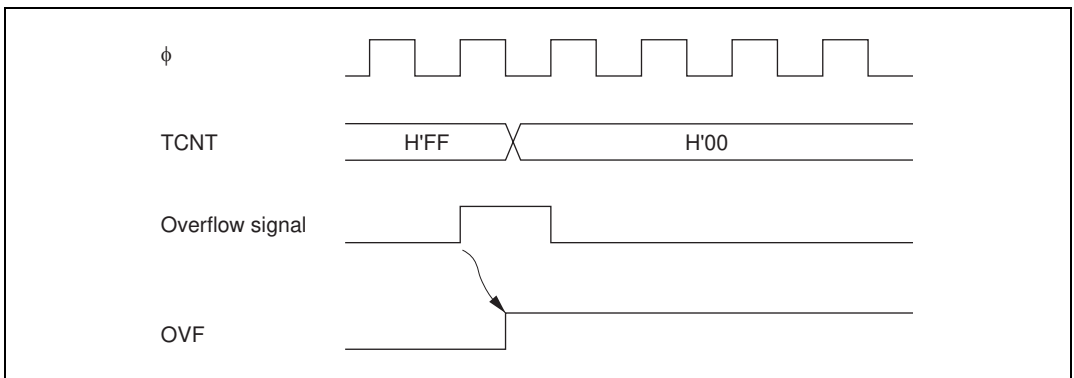

Figure 10.8 Timing of OVF Setting

10.3.5 Operation with Cascaded Connection

If bits CKS2 to CKS0 in either TCR0 or TCR1 are set to B'100, the 8-bit timers of the two channels are cascaded. With this configuration, a single 16-bit timer could be used (16-bit counter mode) or compare matches of the 8-bit channel 0 could be counted by the timer of channel 1 (compare match counter mode). In this case, the timer operates as below.

16-Bit Counter Mode: When bits CKS2 to CKS0 in TCR0 are set to B'100, the timer functions as a single 16-bit timer with channel 0 occupying the upper 8 bits and channel 1 occupying the lower 8 bits.

- Setting of compare match flags
 - The CMF flag in TCSR0 is set to 1 when a 16-bit compare match event occurs.
 - The CMF flag in TCSR1 is set to 1 when a lower 8-bit compare match event occurs.
- Counter clear specification
 - If the CCLR1 and CCLR0 bits in TCR0 have been set for counter clear at compare match, the 16-bit counter (TCNT0 and TCNT1 together) is cleared when a 16-bit compare match event occurs. The 16-bit counter (TCNT0 and TCNT1 together) is cleared even if counter clear by the TMRI0 pin has also been set.
 - The settings of the CCLR1 and CCLR0 bits in TCR1 are ignored. The lower 8 bits cannot be cleared independently.
- Pin output
 - Control of output from the TMO0 pin by bits OS3 to OS0 in TCSR0 is in accordance with the 16-bit compare match conditions.
 - Control of output from the TMO1 pin by bits OS3 to OS0 in TCSR1 is in accordance with the lower 8-bit compare match conditions.

Compare Match Counter Mode: When bits CKS2 to CKS0 in TCR1 are B'100, TCNT1 counts compare match A's for channel 0.

Channels 0 and 1 are controlled independently. Conditions such as setting of the CMF flag, generation of interrupts, output from the TMO pin, and counter clear are in accordance with the settings for each channel.

Usage Note: If the 16-bit counter mode and compare match counter mode are set simultaneously, the input clock pulses for TCNT0 and TCNT1 are not generated and thus the counters will stop operating. Software should therefore avoid using both these modes.

10.4 Interrupts

10.4.1 Interrupt Sources and DTC Activation

There are three 8-bit timer interrupt sources: CMIA, CMIB, and OVI. Their relative priorities are shown in table 10.3. Each interrupt source is set as enabled or disabled by the corresponding interrupt enable bit in TCR, and independent interrupt requests are sent for each to the interrupt controller. It is also possible to activate the DTC by means of CMIA and CMIB interrupts.

Table 10.3 8-Bit Timer Interrupt Sources

Channel	Interrupt Source	Description	DTC Activation	Priority
0	CMIA0	Interrupt by CMFA	Possible	High ↑ Low
	CMIB0	Interrupt by CMFB	Possible	
	OVI0	Interrupt by OVF	Not possible	
1	CMIA1	Interrupt by CMFA	Possible	
	CMIB1	Interrupt by CMFB	Possible	
	OVI1	Interrupt by OVF	Not possible	Low

Note: This table shows the initial state immediately after a reset. The relative channel priorities can be changed by the interrupt controller.

10.4.2 A/D Converter Activation

The A/D converter can be activated only by channel 0 compare match A.

If the ADTE bit in TCSR0 is set to 1 when the CMFA flag is set to 1 by the occurrence of channel 0 compare match A, a request to start A/D conversion is sent to the A/D converter. If the 8-bit timer conversion start trigger has been selected on the A/D converter side at this time, A/D conversion is started.

10.5 Sample Application

In the example below, the 8-bit timer is used to generate a pulse output with a selected duty cycle, as shown in figure 10.9. The control bits are set as follows:

- [1] In TCR, bit CCLR1 is cleared to 0 and bit CCLR0 is set to 1 so that the timer counter is cleared when its value matches the constant in TCORA.
- [2] In TCSR, bits OS3 to OS0 are set to B'0110, causing the output to change to 1 at a TCORA compare match and to 0 at a TCORB compare match.

With these settings, the 8-bit timer provides output of pulses at a rate determined by TCORA with a pulse width determined by TCORB. No software intervention is required.

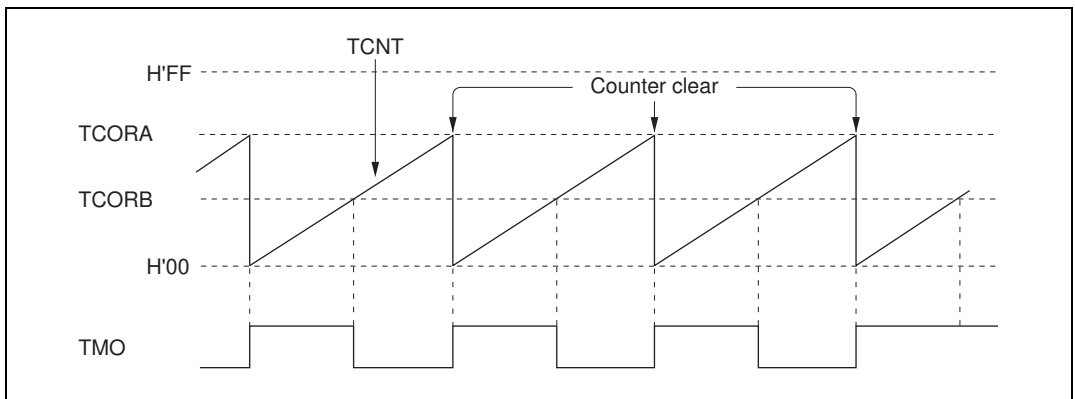

Figure 10.9 Example of Pulse Output

10.6 Usage Notes

Note that the following kinds of contention can occur in the 8-bit timer module.

10.6.1 Contention between TCNT Write and Clear

If a timer counter clock pulse is generated during the T_2 state of a TCNT write cycle, the clear takes priority, so that the counter is cleared and the write is not performed.

Figure 10.10 shows this operation.

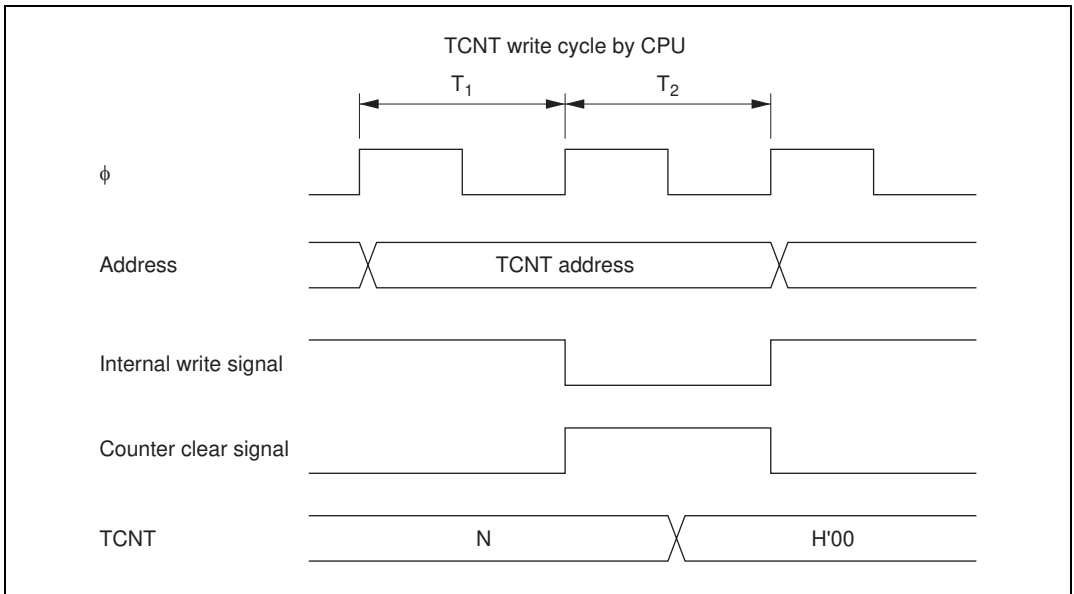

Figure 10.10 Contention between TCNT Write and Clear

10.6.2 Contention between TCNT Write and Increment

If a timer counter clock pulse is generated during the T_2 state of a TCNT write cycle, the write takes priority and the counter is not incremented.

Figure 10.11 shows this operation.

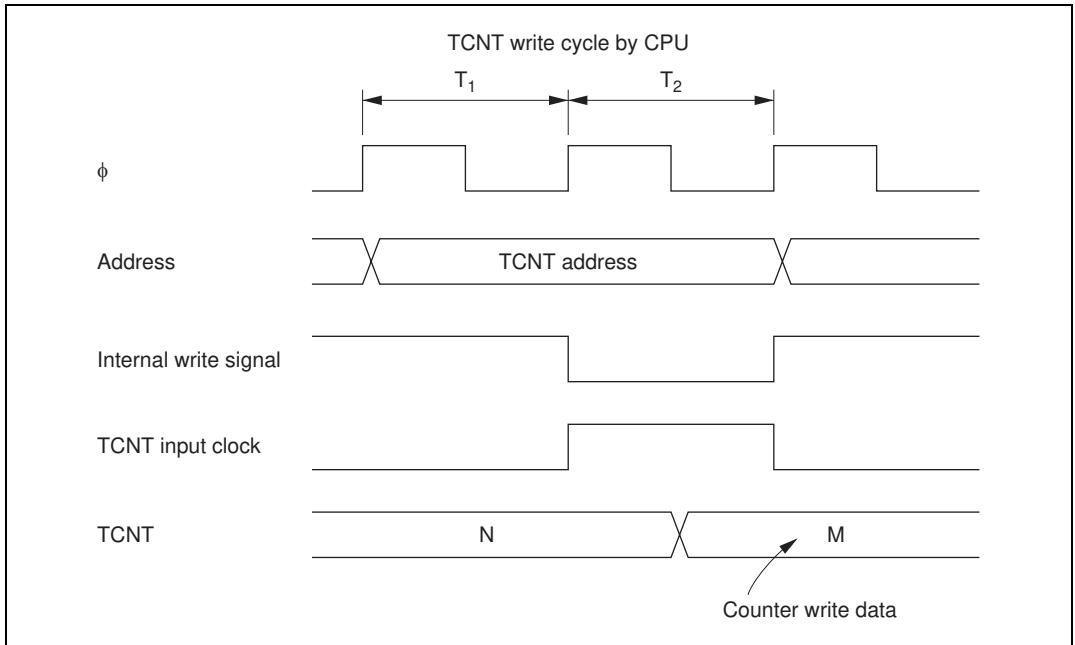

Figure 10.11 Contention between TCNT Write and Increment

10.6.3 Contention between TCOR Write and Compare Match

During the T_2 state of a TCOR write cycle, the TCOR write has priority and the compare match signal is inhibited even if a compare match event occurs.

Figure 10.12 shows this operation.

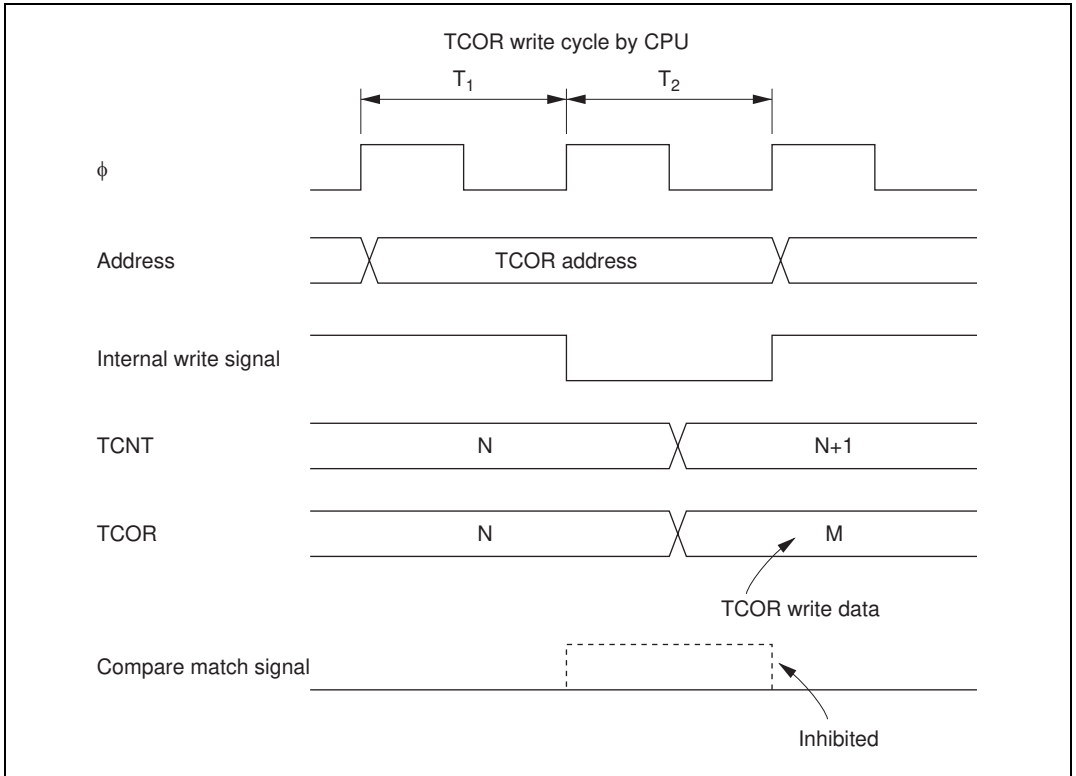

Figure 10.12 Contention between TCOR Write and Compare Match

10.6.4 Contention between Compare Matches A and B

If compare match events A and B occur at the same time, the 8-bit timer operates in accordance with the priorities for the output statuses set for compare match A and compare match B, as shown in table 10.4.

Table 10.4 Timer Output Priorities

Output Setting	Priority
Toggle output	High
1 output	↑
0 output	
No change	

10.6.5 Switching of Internal Clocks and TCNT Operation

TCNT may increment erroneously when the internal clock is switched over. Table 10.5 shows the relationship between the timing at which the internal clock is switched (by writing to the CKS1 and CKS0 bits) and the TCNT operation.

When the TCNT clock is generated from an internal clock, the falling edge of the internal clock pulse is detected. If clock switching causes a change from high to low level, as shown in case 3 in table 10.5, a TCNT clock pulse is generated on the assumption that the switchover is a falling edge. This increments TCNT.

The erroneous incrementation can also happen when switching between internal and external clocks.

Table 10.5 Switching of Internal Clock and TCNT Operation

No.	Timing of Switchover by Means of CKS1 and CKS0 Bits	TCNT Clock Operation
1	Switching from low to low ^{*1}	<p data-bbox="426 248 546 293">Clock before switchover</p> <p data-bbox="426 336 527 381">Clock after switchover</p> <p data-bbox="426 432 539 454">TCNT clock</p> <p data-bbox="426 523 482 545">TCNT</p> <p data-bbox="651 587 775 609">CKS bit write</p>
2	Switching from low to high ^{*2}	<p data-bbox="426 651 546 695">Clock before switchover</p> <p data-bbox="426 738 527 783">Clock after switchover</p> <p data-bbox="426 834 539 857">TCNT clock</p> <p data-bbox="426 925 482 948">TCNT</p> <p data-bbox="807 989 931 1011">CKS bit write</p>
3	Switching from high to low ^{*3}	<p data-bbox="426 1053 546 1098">Clock before switchover</p> <p data-bbox="426 1141 527 1185">Clock after switchover</p> <p data-bbox="426 1236 539 1259">TCNT clock</p> <p data-bbox="426 1327 482 1350">TCNT</p> <p data-bbox="732 1209 747 1232">*4</p> <p data-bbox="732 1391 856 1414">CKS bit write</p>

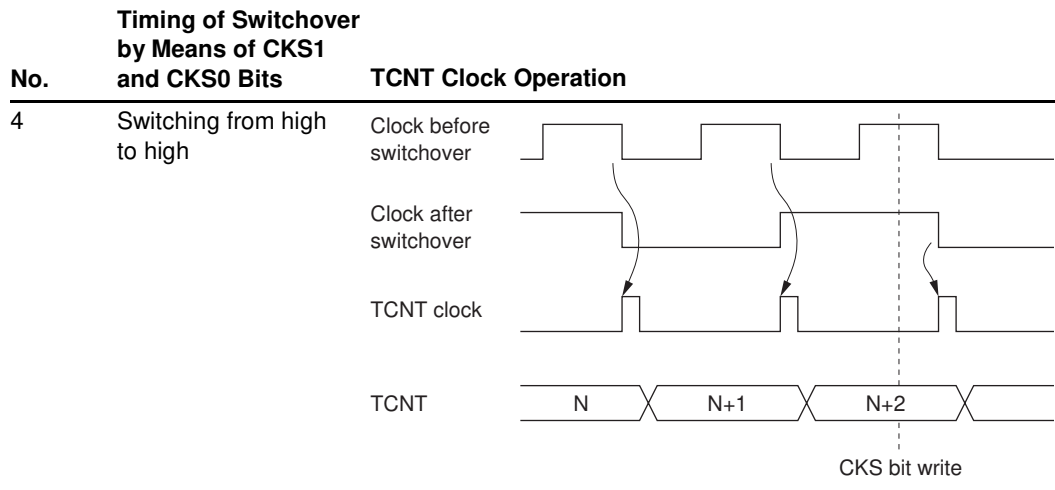

- Notes:
1. Includes switching from low to stop, and from stop to low.
 2. Includes switching from stop to high.
 3. Includes switching from high to stop.
 4. Generated on the assumption that the switchover is a falling edge; TCNT is incremented.

10.6.6 Interrupts and Module Stop Mode

If module stop mode is entered when an interrupt has been requested, it will not be possible to clear the CPU interrupt source or the DTC activation source. Interrupts should therefore be disabled before entering module stop mode.

Section 11 Watchdog Timer

11.1 Overview

The chip has a single-channel on-chip watchdog timer (WDT) for monitoring system operation. The WDT outputs an overflow signal ($\overline{\text{WDTOVF}}$)* if a system crash prevents the CPU from writing to the timer counter, allowing it to overflow. At the same time, the WDT can also generate an internal reset signal for the chip.

When this watchdog function is not needed, the WDT can be used as an interval timer. In interval timer operation, an interval timer interrupt is generated each time the counter overflows.

Note: * The $\overline{\text{WDTOVF}}$ function is not available in the F-ZTAT versions.

11.1.1 Features

WDT features are listed below.

- Switchable between watchdog timer mode and interval timer mode
- $\overline{\text{WDTOVF}}$ output when in watchdog timer mode*
If the counter overflows, the WDT outputs $\overline{\text{WDTOVF}}$. It is possible to select whether or not the entire chip is reset at the same time
- Interrupt generation when in interval timer mode
If the counter overflows, the WDT generates an interval timer interrupt
- Choice of eight counter clock sources

Note: * The $\overline{\text{WDTOVF}}$ function is not available in the F-ZTAT versions.

11.1.2 Block Diagram

Figure 11.1 shows a block diagram of the WDT.

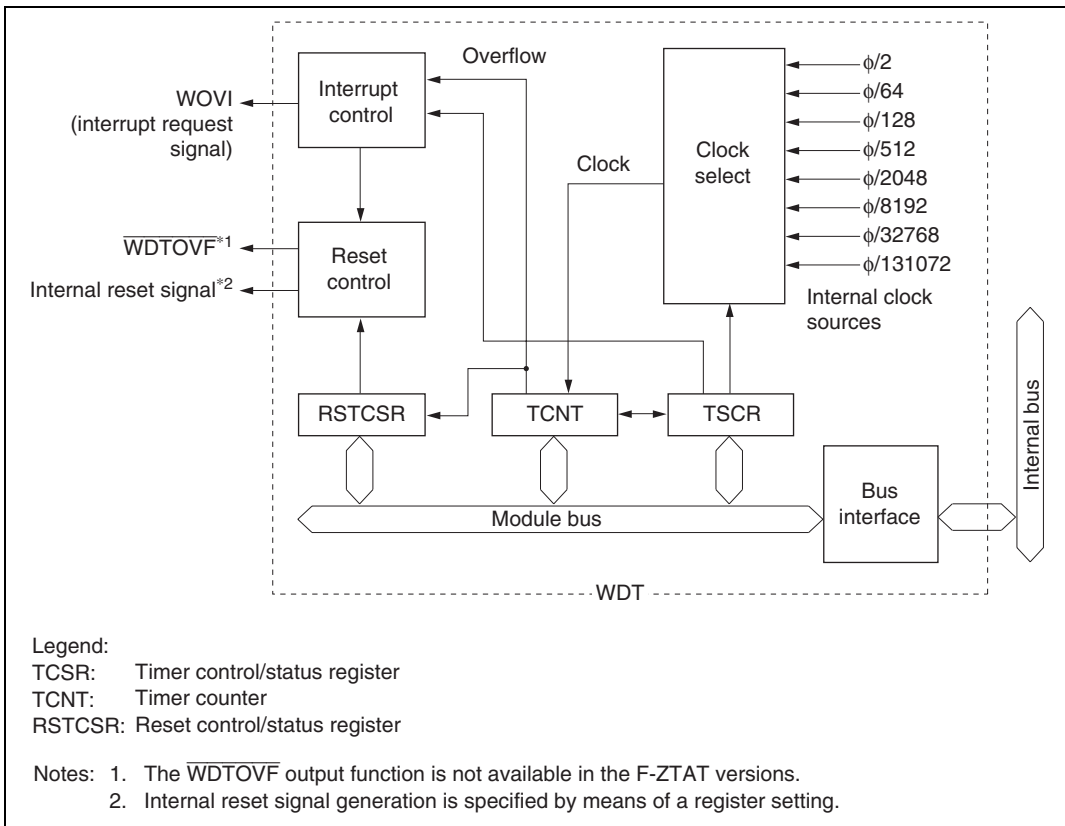

Figure 11.1 Block Diagram of WDT

11.1.3 Pin Configuration

Table 11.1 describes the WDT output pin.

Table 11.1 WDT Pin

Name	Symbol	I/O	Function
Watchdog timer overflow	WDTOVF*	Output	Outputs counter overflow signal in watchdog timer mode

Note: * The WDTOVF function is not available in the F-ZTAT versions.

11.1.4 Register Configuration

The WDT has three registers, as summarized in table 11.2. These registers control clock selection, WDT mode switching, and the reset signal.

Table 11.2 WDT Registers

Name	Abbreviation	R/W	Initial Value	Address* ¹	
				Write* ²	Read
Timer control/status register	TCSR	R/(W)* ³	H'18	H'FFBC	H'FFBC
Timer counter	TCNT	R/W	H'00	H'FFBC	H'FFBD
Reset control/status register	RSTCSR	R/(W)* ³	H'1F	H'FFBE	H'FFBF

Notes: 1. Lower 16 bits of the address.

2. For details of write operations, see section 11.2.4, Notes on Register Access.

3. Only a write of 0 is permitted to bit 7, to clear the flag.

11.2 Register Descriptions

11.2.1 Timer Counter (TCNT)

Bit	:	7	6	5	4	3	2	1	0
Initial value	:	0	0	0	0	0	0	0	0
R/W	:	R/W	R/W	R/W	R/W	R/W	R/W	R/W	R/W

TCNT is an 8-bit readable/writable*¹ up-counter.

When the TME bit is set to 1 in TCSR, TCNT starts counting pulses generated from the internal clock source selected by bits CKS2 to CKS0 in TCSR. When the count overflows (changes from H'FF to H'00), either the watchdog timer overflow signal ($\overline{\text{WDTOVF}}$)*² or an interval timer interrupt (WOVI) is generated, depending on the mode selected by the $\overline{\text{WT/IT}}$ bit in TCSR.

TCNT is initialized to H'00 by a reset, in hardware standby mode, or when the TME bit is cleared to 0. It is not initialized in software standby mode.

- Notes:
1. TCNT is write-protected by a password to prevent accidental overwriting. For details see section 11.2.4, Notes on Register Access.
 2. The $\overline{\text{WDTOVF}}$ function is not available in the F-ZTAT versions.

11.2.2 Timer Control/Status Register (TCSR)

Bit	:	7	6	5	4	3	2	1	0
		OVF	WT/IT	TME	—	—	CKS2	CKS1	CKS0
Initial value	:	0	0	0	1	1	0	0	0
R/W	:	R/(W)*	R/W	R/W	—	—	R/W	R/W	R/W

Note: * Only 0 can be written, to clear the flag.

TCSR is an 8-bit readable/writable* register. Its functions include selecting the clock source to be input to TCNT, and the timer mode.

TCR is initialized to H'18 by a reset and in hardware standby mode. It is not initialized in software standby mode.

Note: * TCSR is write-protected by a password to prevent accidental overwriting. For details see section 11.2.4, Notes on Register Access.

Bit 7—Overflow Flag (OVF): Indicates that TCNT has overflowed from H'FF to H'00, when in interval timer mode. This flag cannot be set during watchdog timer operation.

Bit 7

OVF	Description
0	[Clearing condition] (Initial value) Cleared by reading TCSR when OVF = 1*, then writing 0 to OVF
1	[Setting condition] Set when TCNT overflows (changes from H'FF to H'00) in interval timer mode

Note: * When OVF is polled and the interval timer interrupt is disabled, OVF = 1 must be read at least twice.

Bit 6—Timer Mode Select (WT/IT): Selects whether the WDT is used as a watchdog timer or interval timer. If used as an interval timer, the WDT generates an interval timer interrupt request (WOVI) when TCNT overflows. If used as a watchdog timer, the WDT generates the WDTOVF signal*1 when TCNT overflows.

Bit 6

WT/IT	Description
0	Interval timer: Sends the CPU an interval timer interrupt request (WOVI) when TCNT overflows (Initial value)
1	Watchdog timer: Generates the WDTOVF signal* ¹ when TCNT overflows* ²

Notes: 1. The WDTOVF function is not available in the F-ZTAT versions.

2. For details of the case where TCNT overflows in watchdog timer mode, see section 11.2.3, Reset Control/Status Register (RSTCSR).

Bit 5—Timer Enable (TME): Selects whether TCNT runs or is halted.

Bit 5

TME	Description
0	TCNT is initialized to H'00 and halted (Initial value)
1	TCNT counts

Bits 4 and 3—Reserved: These bits cannot be modified and are always read as 1.

Bits 2 to 0—Clock Select 2 to 0 (CKS2 to CKS0): These bits select one of eight internal clock sources, obtained by dividing the system clock (ϕ), for input to TCNT.

Bit 2 CKS2	Bit 1 CKS1	Bit 0 CKS0	Description	
			Clock	Overflow Period (when $\phi = 20$ MHz)*
0	0	0	$\phi/2$ (Initial value)	25.6 μ s
		1	$\phi/64$	819.2 μ s
	1	0	$\phi/128$	1.6 ms
		1	$\phi/512$	6.6 ms
1	0	0	$\phi/2048$	26.2 ms
		1	$\phi/8192$	104.9 ms
	1	0	$\phi/32768$	419.4 ms
		1	$\phi/131072$	1.68 s

Note: * The overflow period is the time from when TCNT starts counting up from H'00 until overflow occurs.

11.2.3 Reset Control/Status Register (RSTCSR)

Bit	:	7	6	5	4	3	2	1	0
		WOVF	RSTE	—	—	—	—	—	—
Initial value :		0	0	0	1	1	1	1	1
R/W	:	R/(W)*	R/W	R/W	—	—	—	—	—

Note: * Only 0 can be written, to clear the flag.

RSTCSR is an 8-bit readable/writable* register that controls the generation of the internal reset signal when TCNT overflows, and selects the type of internal reset signal.

RSTCSR is initialized to H'1F by a reset signal from the $\overline{\text{RES}}$ pin, but not by the WDT internal reset signal caused by overflows.

Note: * RSTCSR is write-protected by a password to prevent accidental overwriting. For details see section 11.2.4, Notes on Register Access.

Bit 7—Watchdog Timer Overflow Flag (WOVF): Indicates that TCNT has overflowed (changed from H'FF to H'00) during watchdog timer operation. This bit is not set in interval timer mode.

Bit 7

WOVF	Description
0	[Clearing condition] (Initial value) Cleared by reading RSTCSR when WOVF = 1, then writing 0 to WOVF
1	[Setting condition] Set when TCNT overflows (changes from H'FF to H'00) during watchdog timer operation

Bit 6—Reset Enable (RSTE): Specifies whether or not a reset signal is generated in the chip if TCNT overflows during watchdog timer operation.

Bit 6

RSTE	Description
0	Reset signal is not generated if TCNT overflows* (Initial value)
1	Reset signal is generated if TCNT overflows

Note: * The modules within the chip are not reset, but TCNT and TCSR within the WDT are reset.

Bit 5—Reserved: This bit should be written with 0.

Bits 4 to 0—Reserved: These bits cannot be modified and are always read as 1.

11.2.4 Notes on Register Access

The watchdog timer's TCNT, TCSR, and RSTCSR registers differ from other registers in being more difficult to write to. The procedures for writing to and reading these registers are given below.

Writing to TCNT and TCSR: These registers must be written to by a word transfer instruction. They cannot be written to with byte instructions.

Figure 11.2 shows the format of data written to TCNT and TCSR. TCNT and TCSR both have the same write address. For a write to TCNT, the upper byte of the written word must contain H'5A and the lower byte must contain the write data. For a write to TCSR, the upper byte of the written word must contain H'A5 and the lower byte must contain the write data. This transfers the write data from the lower byte to TCNT or TCSR.

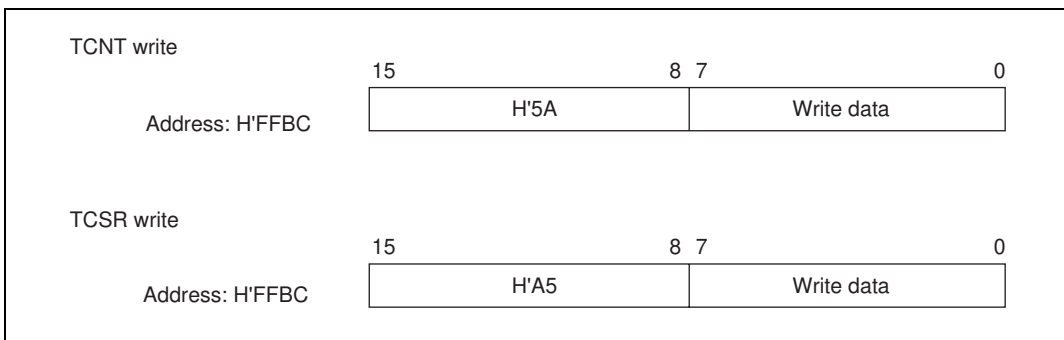

Figure 11.2 Writing to TCNT and TCSR

Writing to RSTCSR: RSTCSR must be written to by a word transfer instruction to address H'FFBE. It cannot be written to with byte instructions.

Figure 11.3 shows the format of data written to RSTCSR. The method of writing 0 to the WOVF bit differs from that for writing to the RSTE bit.

To write 0 to the WOVF bit, the write data must have H'A5 in the upper byte and H'00 in the lower byte. This clears the WOVF bit to 0, but has no effect on the RSTE bit. To write to the RSTE bit, the upper byte must contain H'5A and the lower byte must contain the write data. This writes the value in bit 6 of the lower byte into the RSTE bit, but has no effect on the WOVF bit.

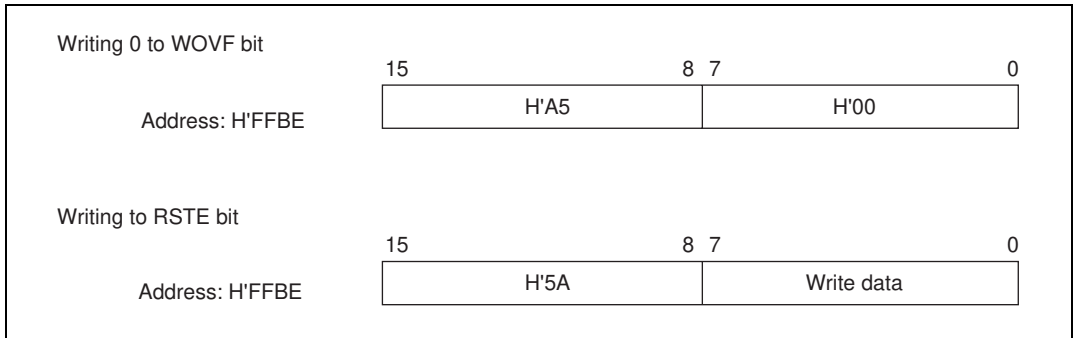

Figure 11.3 Writing to RSTCSR

Reading TCNT, TCSR, and RSTCSR: These registers are read in the same way as other registers. The read addresses are H'FFBC for TCSR, H'FFBD for TCNT, and H'FFBF for RSTCSR.

11.3 Operation

11.3.1 Operation in Watchdog Timer Mode

To use the WDT as a watchdog timer, set the $\overline{WT/IT}$ and TME bits to 1. Software must prevent TCNT overflows by rewriting the TCNT value (normally be writing H'00) before overflow occurs. This ensures that TCNT does not overflow while the system is operating normally. If TCNT overflows without being rewritten because of a system crash or other error, the \overline{WDTOVF} signal* is output. This is shown in figure 11.4. This \overline{WDTOVF} signal* can be used to reset the system. The \overline{WDTOVF} signal* is output for 132 states when RSTE = 1, and for 130 states when RSTE = 0.

If TCNT overflows when 1 is set in the RSTE bit in RSTCSR, a signal that resets the chip internally is generated at the same time as the \overline{WDTOVF} signal*. The internal reset signal is output for 518 states.

If a reset caused by a signal input to the \overline{RES} pin occurs at the same time as a reset caused by a WDT overflow, the RES pin reset has priority and the WOVF bit in RSTCSR is cleared to 0.

Note: * The \overline{WDTOVF} function is not available in the F-ZTAT versions.

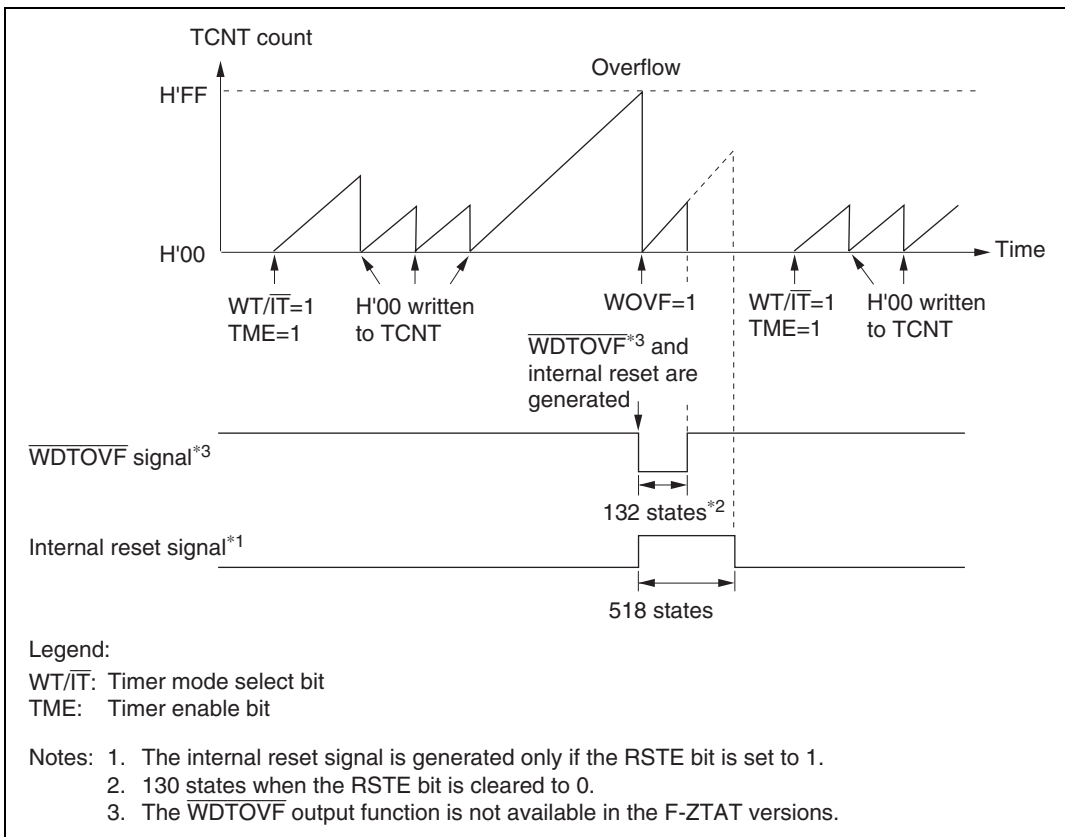

Figure 11.4 Operation in Watchdog Timer Mode

11.3.2 Operation in Interval Timer Mode

To use the WDT as an interval timer, clear the WT/\overline{IT} bit in TCSR to 0 and set the TME bit to 1. An interval timer interrupt (WOVI) is generated each time TCNT overflows, provided that the WDT is operating as an interval timer, as shown in figure 11.5. This function can be used to generate interrupt requests at regular intervals.

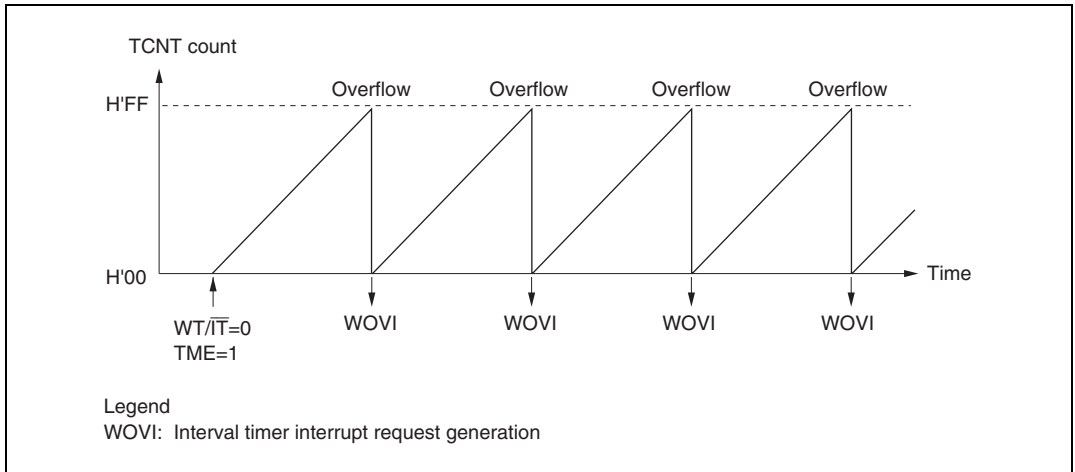

Figure 11.5 Operation in Interval Timer Mode

11.3.3 Timing of Overflow Flag (OVF) Setting

The OVF flag is set to 1 if TCNT overflows during interval timer operation. At the same time, an interval timer interrupt (WOVI) is requested. This timing is shown in figure 11.6.

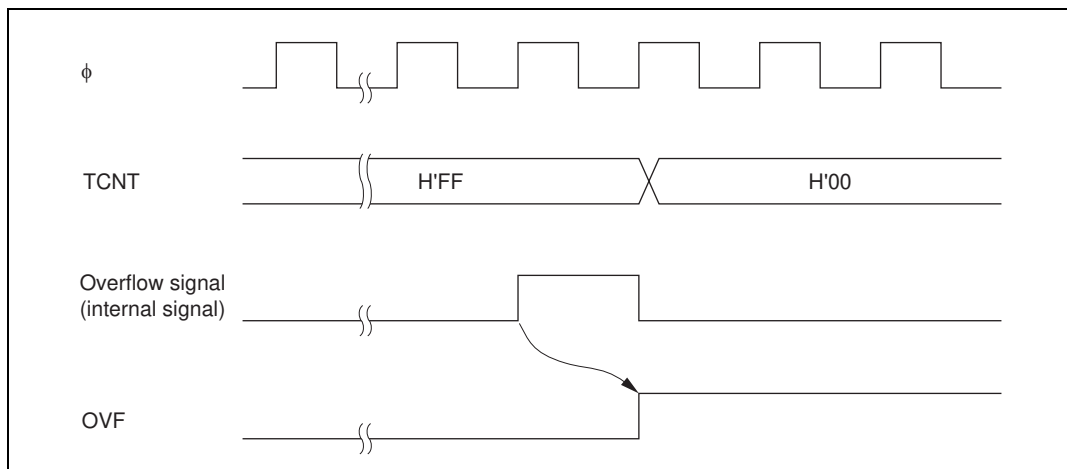

Figure 11.6 Timing of OVF Setting

11.3.4 Timing of Watchdog Timer Overflow Flag (WOVF) Setting

The WOVF flag is set to 1 if TCNT overflows during watchdog timer operation. At the same time, the $\overline{\text{WDTOVF}}$ signal* goes low. If TCNT overflows while the RSTE bit in RSTCSR is set to 1, an internal reset signal is generated for the entire chip. Figure 11.7 shows the timing in this case.

Note: * The $\overline{\text{WDTOVF}}$ output function is not available in the F-ZTAT versions.

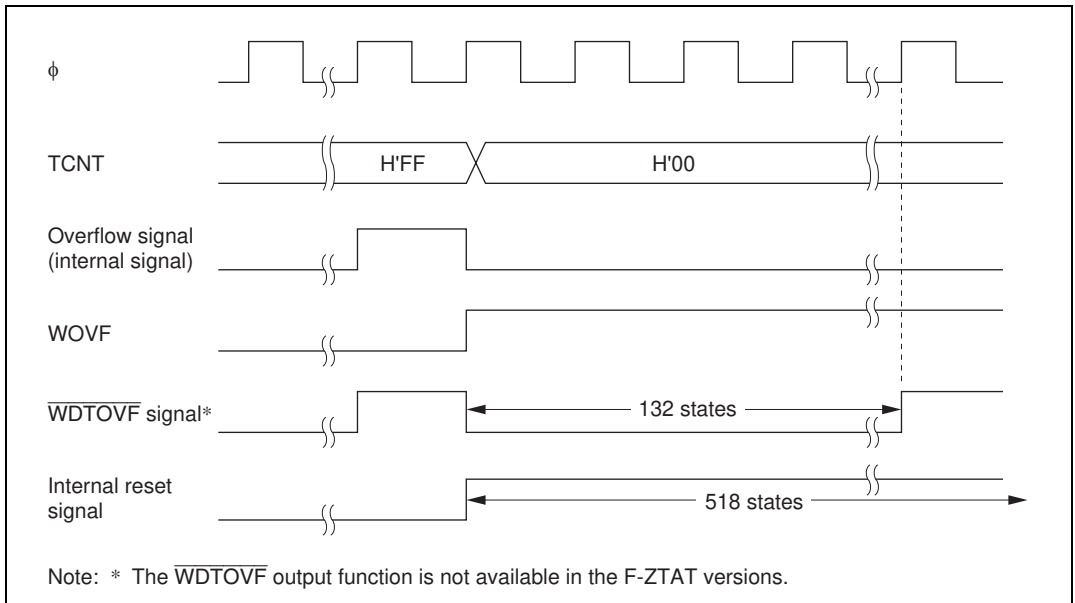

Figure 11.7 Timing of WOVF Setting

11.4 Interrupts

During interval timer mode operation, an overflow generates an interval timer interrupt (WOVI). The interval timer interrupt is requested whenever the OVF flag is set to 1 in TCSR.

11.5 Usage Notes

11.5.1 Contention between Timer Counter (TCNT) Write and Increment

If a timer counter clock pulse is generated during the T_2 state of a TCNT write cycle, the write takes priority and the timer counter is not incremented. Figure 11.8 shows this operation.

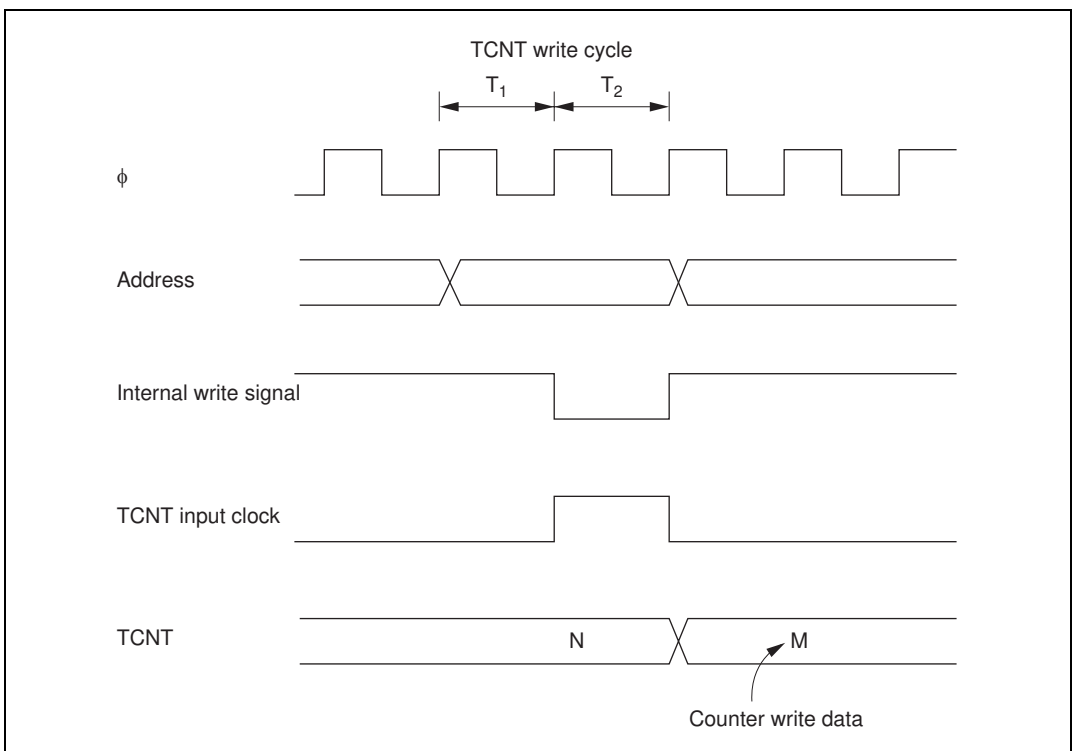

Figure 11.8 Contention between TCNT Write and Increment

11.5.2 Changing Value of CKS2 to CKS0

If bits CKS2 to CKS0 in TCSR are written to while the WDT is operating, errors may occur in the incrementation. Software must stop the watchdog timer (by clearing the TME bit to 0) before changing the value of bits CKS2 to CKS0.

11.5.3 Switching between Watchdog Timer Mode and Interval Timer Mode

If the mode is switched from watchdog timer to interval timer, or vice versa, while the WDT is operating, errors may occur in the incrementation. Software must stop the watchdog timer (by clearing the TME bit to 0) before switching the mode.

11.5.4 System Reset by $\overline{\text{WDTOVF}}$ Signal*

If the $\overline{\text{WDTOVF}}$ output signal* is input to the $\overline{\text{RES}}$ pin of the chip, the chip will not be initialized correctly. Make sure that the $\overline{\text{WDTOVF}}$ signal* is not input logically to the $\overline{\text{RES}}$ pin. To reset the entire system by means of the $\overline{\text{WDTOVF}}$ signal*, use the circuit shown in figure 11.9.

Note: * The $\overline{\text{WDTOVF}}$ output function is not available in the F-ZTAT versions.

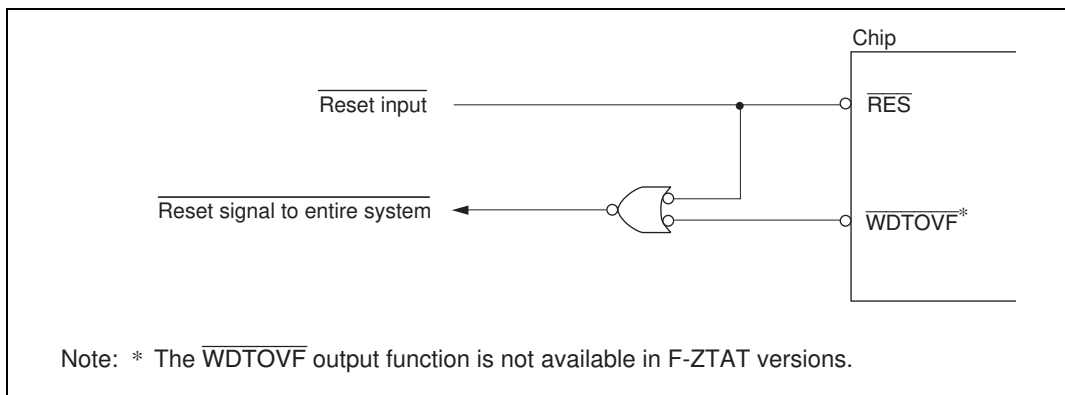

Figure 11.9 Circuit for System Reset by $\overline{\text{WDTOVF}}$ Signal (Example)

11.5.5 Internal Reset in Watchdog Timer Mode

The chip is not reset internally if TCNT overflows while the RSTE bit is cleared to 0 during watchdog timer operation, but TCNT and TSCR of the WDT are reset.

TCNT, TCSR, and RSTCR cannot be written to while the $\overline{\text{WDTOVF}}$ signal* is low. Also note that a read of the WOVF flag is not recognized during this period. To clear the WOVF flag, therefore, read RSTCSR after the $\overline{\text{WDTOVF}}$ signal* goes high, then write 0 to the WOVF flag.

Note: * The $\overline{\text{WDTOVF}}$ output function is not available in the F-ZTAT versions.

Section 12 Serial Communication Interface (SCI)

12.1 Overview

The chip is equipped with a serial communication interface (SCI) that can handle both asynchronous and synchronous serial communication. A function is also provided for serial communication between processors (multiprocessor communication function).

12.1.1 Features

SCI features are listed below.

- Choice of asynchronous or synchronous serial communication mode
 - Asynchronous mode
 - Serial data communication executed using an asynchronous system in which synchronization is achieved character by character
 - Serial data communication can be carried out with standard asynchronous communication chips such as a Universal Asynchronous Receiver/Transmitter (UART) or Asynchronous Communication Interface Adapter (ACIA)
 - A multiprocessor communication function is provided that enables serial data communication with a number of processors
 - Choice of 12 serial data transfer formats
 - Data length : 7 or 8 bits
 - Stop bit length : 1 or 2 bits
 - Parity : Even, odd, or none
 - Multiprocessor bit : 1 or 0
 - Receive error detection : Parity, overrun, and framing errors
 - Break detection : Break can be detected by reading the RxD pin level directly in case of a framing error
 - Synchronous mode
 - Serial data communication synchronized with a clock
 - Serial data communication can be carried out with other chips that have a synchronous communication function
 - One serial data transfer format
 - Data length : 8 bits
 - Receive error detection : Overrun errors detected

- Full-duplex communication capability
 - The transmitter and receiver are mutually independent, enabling transmission and reception to be executed simultaneously
 - Double-buffering is used in both the transmitter and the receiver, enabling continuous transmission and continuous reception of serial data
- Choice of LSB-first or MSB-first transfer
 - Can be selected regardless of the communication mode* (except in the case of asynchronous mode 7-bit data)
- Built-in baud rate generator allows any bit rate to be selected
- Choice of serial clock source: internal clock from baud rate generator or external clock from SCK pin
- Four interrupt sources
 - Four interrupt sources—transmit-data-empty, transmit-end, receive-data-full, and receive error—that can issue requests independently
 - The transmit-data-empty and receive-data-full interrupts can activate the data transfer controller (DTC) to execute data transfer
- Module stop mode can be set
 - As the initial setting, SCI operation is halted. Register access is enabled by exiting module stop mode

Note: * Descriptions in this section refer to LSB-first transfer.

12.1.2 Block Diagram

Figure 12.1 shows a block diagram of the SCI.

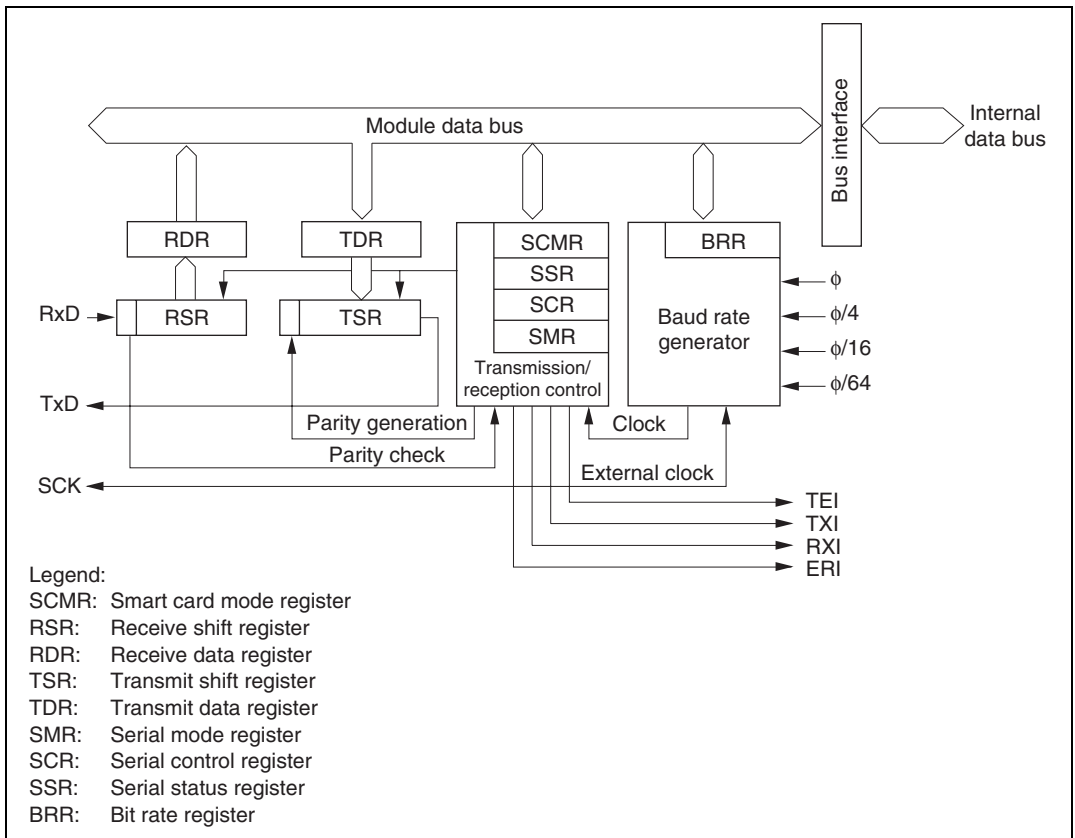

Figure 12.1 Block Diagram of SCI

12.1.3 Pin Configuration

Table 12.1 shows the serial pins for each SCI channel.

Table 12.1 SCI Pins

Channel	Pin Name	Symbol	I/O	Function
0	Serial clock pin 0	SCK0	I/O	SCI0 clock input/output
	Receive data pin 0	RxD0	Input	SCI0 receive data input
	Transmit data pin 0	TxD0	Output	SCI0 transmit data output
1	Serial clock pin 1	SCK1	I/O	SCI1 clock input/output
	Receive data pin 1	RxD1	Input	SCI1 receive data input
	Transmit data pin 1	TxD1	Output	SCI1 transmit data output

12.1.4 Register Configuration

The SCI has the internal registers shown in table 12.2. These registers are used to specify asynchronous mode or synchronous mode, the data format, and the bit rate, and to control the transmitter/receiver.

Table 12.2 SCI Registers

Channel	Name	Abbreviation	R/W	Initial Value	Address*2
0	Serial mode register 0	SMR0	R/W	H'00	H'FF78
	Bit rate register 0	BRR0	R/W	H'FF	H'FF79
	Serial control register 0	SCR0	R/W	H'00	H'FF7A
	Transmit data register 0	TDR0	R/W	H'FF	H'FF7B
	Serial status register 0	SSR0	R/(W)*1	H'84	H'FF7C
	Receive data register 0	RDR0	R	H'00	H'FF7D
	Smart card mode register 0	SCMR0	R/W	H'F2	H'FF7E
1	Serial mode register 1	SMR1	R/W	H'00	H'FF80
	Bit rate register 1	BRR1	R/W	H'FF	H'FF81
	Serial control register 1	SCR1	R/W	H'00	H'FF82
	Transmit data register 1	TDR1	R/W	H'FF	H'FF83
	Serial status register 1	SSR1	R/(W)*1	H'84	H'FF84
	Receive data register 1	RDR1	R	H'00	H'FF85
	Smart card mode register 1	SCMR1	R/W	H'F2	H'FF86
All	Module stop control register	MSTPCR	R/W	H'3FFF	H'FF3C

Notes: 1. Can only be written with 0 for flag clearing.

2. Lower 16 bits of the address.

12.2 Register Descriptions

12.2.1 Receive Shift Register (RSR)

Bit	:	7	6	5	4	3	2	1	0
R/W	:	—	—	—	—	—	—	—	—

RSR is a register used to receive serial data.

The SCI sets serial data input from the RxD pin in RSR in the order received, starting with the LSB (bit 0), and converts it to parallel data. When one byte of data has been received, it is transferred to RDR automatically.

RSR cannot be directly read or written to by the CPU.

12.2.2 Receive Data Register (RDR)

Bit	:	7	6	5	4	3	2	1	0
Initial value	:	0	0	0	0	0	0	0	0
R/W	:	R	R	R	R	R	R	R	R

RDR is a register that stores received serial data.

When the SCI has received one byte of serial data, it transfers the received serial data from RSR to RDR where it is stored, and completes the receive operation. After this, RSR is receive-enabled.

Since RSR and RDR function as a double buffer in this way, continuous receive operations can be performed.

RDR is a read-only register, and cannot be written to by the CPU.

RDR is initialized to H'00 by a reset, and in standby mode or module stop mode.

12.2.3 Transmit Shift Register (TSR)

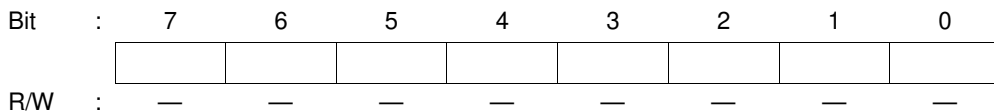

TSR is a register used to transmit serial data.

To perform serial data transmission, the SCI first transfers transmit data from TDR to TSR, then sends the data to the TxD pin starting with the LSB (bit 0).

When transmission of one byte is completed, the next transmit data is transferred from TDR to TSR, and transmission started, automatically. However, data transfer from TDR to TSR is not performed if the TDRE bit in SSR is set to 1.

TSR cannot be directly read or written to by the CPU.

12.2.4 Transmit Data Register (TDR)

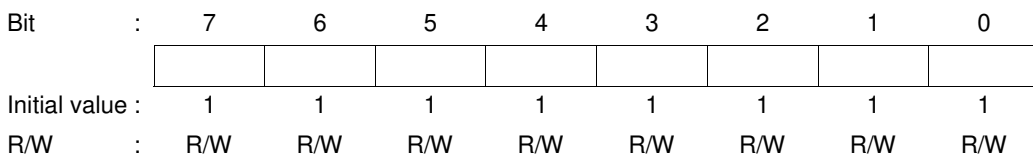

TDR is an 8-bit register that stores data for serial transmission.

When the SCI detects that TSR is empty, it transfers the transmit data written in TDR to TSR and starts serial transmission. Continuous serial transmission can be carried out by writing the next transmit data to TDR during serial transmission of the data in TSR.

TDR can be read or written to by the CPU at all times.

TDR is initialized to H'FF by a reset, and in standby mode or module stop mode.

12.2.5 Serial Mode Register (SMR)

Bit	:	7	6	5	4	3	2	1	0
		C/ \bar{A}	CHR	PE	O/ \bar{E}	STOP	MP	CKS1	CKS0
Initial value :		0	0	0	0	0	0	0	0
R/W	:	R/W	R/W	R/W	R/W	R/W	R/W	R/W	R/W

SMR is an 8-bit register used to set the SCI's serial transfer format and select the baud rate generator clock source.

SMR can be read or written to by the CPU at all times.

SMR is initialized to H'00 by a reset and in hardware standby mode. In software standby mode and module stop mode it retains its previous state.

Bit 7—Communication Mode (C/ \bar{A}): Selects asynchronous mode or synchronous mode as the SCI operating mode.

Bit 7

C/ \bar{A}	Description
0	Asynchronous mode (Initial value)
1	Synchronous mode

Bit 6—Character Length (CHR): Selects 7 or 8 bits as the data length in asynchronous mode. In synchronous mode, a fixed data length of 8 bits is used regardless of the CHR setting.

Bit 6

CHR	Description
0	8-bit data (Initial value)
1	7-bit data*

Note: * When 7-bit data is selected, the MSB (bit 7) of TDR is not transmitted, and it is not possible to choose between LSB-first or MSB-first transfer.

Bit 5—Parity Enable (PE): In asynchronous mode, selects whether or not parity bit addition is performed in transmission, and parity bit checking in reception. In synchronous mode and with a multiprocessor format, parity bit addition and checking is not performed, regardless of the PE bit setting.

Bit 5

PE	Description
0	Parity bit addition and checking disabled (Initial value)
1	Parity bit addition and checking enabled*

Note:* When the PE bit is set to 1, the parity (even or odd) specified by the O/\bar{E} bit is added to transmit data before transmission. In reception, the parity bit is checked for the parity (even or odd) specified by the O/\bar{E} bit.

Bit 4—Parity Mode (O/\bar{E}): Selects either even or odd parity for use in parity addition and checking.

The O/\bar{E} bit setting is only valid when the PE bit is set to 1, enabling parity bit addition and checking, in asynchronous mode. The O/\bar{E} bit setting is invalid in synchronous mode, and when parity addition and checking is disabled in asynchronous mode.

Bit 4

O/\bar{E}	Description
0	Even parity* ¹ (Initial value)
1	Odd parity* ²

Notes: 1. When even parity is set, parity bit addition is performed in transmission so that the total number of 1 bits in the transmit character plus the parity bit is even.
In reception, a check is performed to see if the total number of 1 bits in the receive character plus the parity bit is even.

2. When odd parity is set, parity bit addition is performed in transmission so that the total number of 1 bits in the transmit character plus the parity bit is odd.
In reception, a check is performed to see if the total number of 1 bits in the receive character plus the parity bit is odd.

Bit 3—Stop Bit Length (STOP): Selects 1 or 2 bits as the stop bit length in asynchronous mode. The STOP bits setting is only valid in asynchronous mode. If synchronous mode is set the STOP bit setting is invalid since stop bits are not added.

Bit 3

STOP	Description
0	1 stop bit: In transmission, a single 1-bit (stop bit) is added to the end of a transmit character before it is sent. (Initial value)
1	2 stop bits: In transmission, two 1-bits (stop bits) are added to the end of a transmit character before it is sent.

In reception, only the first stop bit is checked, regardless of the STOP bit setting. If the second stop bit is 1, it is treated as a stop bit; if it is 0, it is treated as the start bit of the next transmit character.

Bit 2—Multiprocessor Mode (MP): Selects multiprocessor format. When multiprocessor format is selected, the PE bit and O/\bar{E} bit parity settings are invalid. The MP bit setting is only valid in asynchronous mode; it is invalid in synchronous mode.

For details of the multiprocessor communication function, see section 12.3.3, Multiprocessor Communication Function.

Bit 2

MP	Description
0	Multiprocessor function disabled (Initial value)
1	Multiprocessor format selected

Bits 1 and 0—Clock Select 1 and 0 (CKS1, CKS0): These bits select the clock source for the baud rate generator. The clock source can be selected from ϕ , $\phi/4$, $\phi/16$, and $\phi/64$, according to the setting of bits CKS1 and CKS0.

For the relation between the clock source, the bit rate register setting, and the baud rate, see section 12.2.8, Bit Rate Register (BRR).

Bit 1 CKS1	Bit 0 CKS0	Description
0	0	ϕ clock (Initial value)
	1	$\phi/4$ clock
1	0	$\phi/16$ clock
	1	$\phi/64$ clock

12.2.6 Serial Control Register (SCR)

Bit	:	7	6	5	4	3	2	1	0
		TIE	RIE	TE	RE	MPIE	TEIE	CKE1	CKE0
Initial value	:	0	0	0	0	0	0	0	0
R/W	:	R/W	R/W	R/W	R/W	R/W	R/W	R/W	R/W

SCR is a register that performs enabling or disabling of SCI transfer operations, serial clock output in asynchronous mode, and interrupt requests, and selection of the serial clock source.

SCR can be read or written to by the CPU at all times.

SCR is initialized to H'00 by a reset and in hardware standby mode. In software standby mode and module stop mode it retains its previous state.

Bit 7—Transmit Interrupt Enable (TIE): Enables or disables transmit-data-empty interrupt (TXI) request generation when serial transmit data is transferred from TDR to TSR and the TDRE flag in SSR is set to 1.

Bit 7

TIE	Description
0	Transmit-data-empty interrupt (TXI) requests disabled* (Initial value)
1	Transmit-data-empty interrupt (TXI) requests enabled

Note:* TXI interrupt request cancellation can be performed by reading 1 from the TDRE flag, then clearing it to 0, or by clearing the TIE bit to 0.

Bit 6—Receive Interrupt Enable (RIE): Enables or disables receive-data-full interrupt (RXI) request and receive-error interrupt (ERI) request generation when serial receive data is transferred from RSR to RDR and the RDRF flag in SSR is set to 1.

Bit 6

RIE	Description
0	Receive-data-full interrupt (RXI) request and receive-error interrupt (ERI) request disabled* (Initial value)
1	Receive-data-full interrupt (RXI) request and receive-error interrupt (ERI) request enabled

Note:* RXI and ERI interrupt request cancellation can be performed by reading 1 from the RDRF flag, or the FER, PER, or ORER flag, then clearing the flag to 0, or by clearing the RIE bit to 0.

Bit 5—Transmit Enable (TE): Enables or disables the start of serial transmission by the SCI.

Bit 5

TE	Description
0	Transmission disabled* ¹ (Initial value)
1	Transmission enabled* ²

Notes: 1. The TDRE flag in SSR is fixed at 1.
 2. In this state, serial transmission is started when transmit data is written to TDR and the TDRE flag in SSR is cleared to 0.
 SMR setting must be performed to decide the transfer format before setting the TE bit to 1.

Bit 4—Receive Enable (RE): Enables or disables the start of serial reception by the SCI.

Bit 4

RE	Description
0	Reception disabled* ¹ (Initial value)
1	Reception enabled* ²

Notes: 1. Clearing the RE bit to 0 does not affect the RDRF, FER, PER, and ORER flags, which retain their states.
 2. Serial reception is started in this state when a start bit is detected in asynchronous mode or serial clock input is detected in synchronous mode.
 SMR setting must be performed to decide the transfer format before setting the RE bit to 1.

Bit 3—Multiprocessor Interrupt Enable (MPIE): Enables or disables multiprocessor interrupts. The MPIE bit setting is only valid in asynchronous mode when the MP bit in SMR is set to 1.

The MPIE bit setting is invalid in synchronous mode or when the MP bit is cleared to 0.

Bit 3

MPIE	Description
0	Multiprocessor interrupts disabled (normal reception performed) (Initial value) [Clearing conditions] <ul style="list-style-type: none"> • When the MPIE bit is cleared to 0 • When data with MPB = 1 is received
1	Multiprocessor interrupts enabled* Receive-data-full interrupt (RXI) requests, receive-error interrupt (ERI) requests, and setting of the RDRF, FER, and ORER flags in SSR are disabled until data with the multiprocessor bit set to 1 is received.

Note: *When receive data including MPB = 0 is received, receive data transfer from RSR to RDR, receive error detection, and setting of the RDRF, FER, and ORER flags in SSR, is not performed. When receive data including MPB = 1 is received, the MPB bit in SSR is set to 1, the MPIE bit is cleared to 0 automatically, and generation of RXI and ERI interrupts (when the TIE and RIE bits in SCR are set to 1) and FER and ORER flag setting is enabled.

Bit 2—Transmit End Interrupt Enable (TEIE): Enables or disables transmit-end interrupt (TEI) request generation when there is no valid transmit data in TDR in MSB data transmission.

Bit 2

TEIE	Description
0	Transmit end interrupt (TEI) request disabled* (Initial value)
1	Transmit end interrupt (TEI) request enabled*

Note: *TEI cancellation can be performed by reading 1 from the TDRE flag in SSR, then clearing it to 0 and clearing the TEND flag to 0, or by clearing the TEIE bit to 0.

Bits 1 and 0—Clock Enable 1 and 0 (CKE1, CKE0): These bits are used to select the SCI clock source and enable or disable clock output from the SCK pin. The combination of the CKE1 and CKE0 bits determines whether the SCK pin functions as an I/O port, the serial clock output pin, or the serial clock input pin.

The setting of the CKE0 bit, however, is only valid for internal clock operation (CKE1 = 0) in asynchronous mode. The CKE0 bit setting is invalid in synchronous mode, and in the case of external clock operation (CKE1 = 1). Set CKE1 and CKE0 before determining the SCI operating mode with SMR.

For details of clock source selection, see table 12.9.

Bit 1 CKE1	Bit 0 CKE0	Description	
0	0	Asynchronous mode	Internal clock/SCK pin functions as I/O port ^{*1}
		Synchronous mode	Internal clock/SCK pin functions as serial clock output
	1	Asynchronous mode	Internal clock/SCK pin functions as clock output ^{*2}
		Synchronous mode	Internal clock/SCK pin functions as serial clock output
1	0	Asynchronous mode	External clock/SCK pin functions as clock input ^{*3}
		Synchronous mode	External clock/SCK pin functions as serial clock input
	1	Asynchronous mode	External clock/SCK pin functions as clock input ^{*3}
		Synchronous mode	External clock/SCK pin functions as serial clock input

Notes: 1. Initial value

2. Outputs a clock of the same frequency as the bit rate.

3. Inputs a clock with a frequency 16 times the bit rate.

12.2.7 Serial Status Register (SSR)

Bit	:	7	6	5	4	3	2	1	0
		TDRE	RDRF	ORER	FER	PER	TEND	MPB	MPBT
Initial value	:	1	0	0	0	0	1	0	0
R/W	:	R/(W)*	R/(W)*	R/(W)*	R/(W)*	R/(W)*	R	R	R/W

Note: * Only 0 can be written, to clear the flag.

SSR is an 8-bit register containing status flags that indicate the operating status of the SCI, and multiprocessor bits.

SSR can be read or written to by the CPU at all times. However, 1 cannot be written to flags TDRE, RDRF, ORER, PER, and FER. Also note that in order to clear these flags they must be read as 1 beforehand. The TEND flag and MPB flag are read-only flags and cannot be modified.

SSR is initialized to H'84 by a reset, and in standby mode or module stop mode.

Bit 7—Transmit Data Register Empty (TDRE): Indicates that data has been transferred from TDR to TSR and the next serial data can be written to TDR.

Bit 7

TDRE	Description
0	[Clearing conditions] <ul style="list-style-type: none"> When 0 is written to TDRE after reading TDRE = 1 When the DTC is activated by a TXI interrupt and writes data to TDR
1	[Setting conditions] (Initial value) <ul style="list-style-type: none"> When the TE bit in SCR is 0 When data is transferred from TDR to TSR and data can be written to TDR

Bit 6—Receive Data Register Full (RDRF): Indicates that the received data is stored in RDR.

Bit 6

RDRF	Description
0	[Clearing conditions] (Initial value) <ul style="list-style-type: none"> • When 0 is written to RDRF after reading RDRF = 1 • When the DTC is activated by an RXI interrupt and reads data from RDR
1	[Setting condition] When serial reception ends normally and receive data is transferred from RSR to RDR

Note: RDR and the RDRF flag are not affected and retain their previous values when an error is detected during reception or when the RE bit in SCR is cleared to 0.

If reception of the next data is completed while the RDRF flag is still set to 1, an overrun error will occur and the receive data will be lost.

Bit 5—Overrun Error (ORER): Indicates that an overrun error occurred during reception, causing abnormal termination.

Bit 5

ORER	Description
0	[Clearing condition] (Initial value)*1 When 0 is written to ORER after reading ORER = 1
1	[Setting condition] When the next serial reception is completed while RDRF = 1*2

Notes: 1. The ORER flag is not affected and retains its previous state when the RE bit in SCR is cleared to 0.

2. The receive data prior to the overrun error is retained in RDR, and the data received subsequently is lost. Also, subsequent serial reception cannot be continued while the ORER flag is set to 1. In synchronous mode, serial transmission cannot be continued, either.

Bit 4—Framing Error (FER): Indicates that a framing error occurred during reception in asynchronous mode, causing abnormal termination.

Bit 4

FER	Description
0	[Clearing condition] (Initial value) ^{*1} When 0 is written to FER after reading FER = 1
1	[Setting condition] When the SCI checks the stop bit at the end of the receive data when reception ends, and the stop bit is 0 ^{*2}

- Notes:
1. The FER flag is not affected and retains its previous state when the RE bit in SCR is cleared to 0.
 2. In 2-stop-bit mode, only the first stop bit is checked for a value of 0; the second stop bit is not checked. If a framing error occurs, the receive data is transferred to RDR but the RDRF flag is not set. Also, subsequent serial reception cannot be continued while the FER flag is set to 1. In synchronous mode, serial transmission cannot be continued, either.

Bit 3—Parity Error (PER): Indicates that a parity error occurred during reception using parity addition in asynchronous mode, causing abnormal termination.

Bit 3

PER	Description
0	[Clearing condition] (Initial value) ^{*1} When 0 is written to PER after reading PER = 1
1	[Setting condition] When, in reception, the number of 1 bits in the receive data plus the parity bit does not match the parity setting (even or odd) specified by the O/ \bar{E} bit in SMR ^{*2}

- Notes:
1. The PER flag is not affected and retains its previous state when the RE bit in SCR is cleared to 0.
 2. If a parity error occurs, the receive data is transferred to RDR but the RDRF flag is not set. Also, subsequent serial reception cannot be continued while the PER flag is set to 1. In synchronous mode, serial transmission cannot be continued, either.

Bit 2—Transmit End (TEND): Indicates that there is no valid data in TDR when the last bit of the transmit character is sent, and transmission has been ended.

The TEND flag is read-only and cannot be modified.

Bit 2

TEND	Description
0	[Clearing conditions] <ul style="list-style-type: none"> When 0 is written to TDRE after reading TDRE = 1 When the DTC is activated by a TXI interrupt and writes data to TDR
1	[Setting conditions] (Initial value) <ul style="list-style-type: none"> When the TE bit in SCR is 0 When TDRE = 1 at transmission of the last bit of a 1-byte serial transmit character

Bit 1—Multiprocessor Bit (MPB): When reception is performed using multiprocessor format in asynchronous mode, MPB stores the multiprocessor bit in the receive data.

MPB is a read-only bit, and cannot be modified.

Bit 1

MPB	Description
0	[Clearing condition] (Initial value)* When data with a 0 multiprocessor bit is received
1	[Setting condition] When data with a 1 multiprocessor bit is received

Note: * Retains its previous state when the RE bit in SCR is cleared to 0 with multiprocessor format.

Bit 0—Multiprocessor Bit Transfer (MPBT): When transmission is performed using multiprocessor format in asynchronous mode, MPBT stores the multiprocessor bit to be added to the transmit data.

The MPBT bit setting is invalid when multiprocessor format is not used, when not transmitting, and in synchronous mode.

Bit 0

MPBT	Description
0	Data with a 0 multiprocessor bit is transmitted (Initial value)
1	Data with a 1 multiprocessor bit is transmitted

12.2.8 Bit Rate Register (BRR)

Bit	:	7	6	5	4	3	2	1	0
		<input type="checkbox"/>	<input type="checkbox"/>	<input type="checkbox"/>	<input type="checkbox"/>	<input type="checkbox"/>	<input type="checkbox"/>	<input type="checkbox"/>	<input type="checkbox"/>
Initial value :		1	1	1	1	1	1	1	1
R/W	:	R/W	R/W	R/W	R/W	R/W	R/W	R/W	R/W

BRR is an 8-bit register that sets the serial transfer bit rate in accordance with the baud rate generator operating clock selected by bits CKS1 and CKS0 in SMR.

BRR can be read or written to by the CPU at all times.

BRR is initialized to H'FF by a reset and in hardware standby mode. In software standby mode and module stop mode it retains its previous state.

As baud rate generator control is performed independently for each channel, different values can be set for each channel.

Table 12.3 shows sample BRR settings in asynchronous mode, and table 12.4 shows sample BRR settings in synchronous mode.

Table 12.3 BRR Settings for Various Bit Rates (Asynchronous Mode)

Bit Rate (bits/s)	$\phi = 2 \text{ MHz}$			$\phi = 2.097152 \text{ MHz}$			$\phi = 2.4576 \text{ MHz}$			$\phi = 3 \text{ MHz}$		
	n	N	Error (%)	n	N	Error (%)	n	N	Error (%)	n	N	Error (%)
110	1	141	0.03	1	148	-0.04	1	174	-0.26	1	212	0.03
150	1	103	0.16	1	108	0.21	1	127	0.00	1	155	0.16
300	0	207	0.16	0	217	0.21	0	255	0.00	1	77	0.16
600	0	103	0.16	0	108	0.21	0	127	0.00	0	155	0.16
1200	0	51	0.16	0	54	-0.70	0	63	0.00	0	77	0.16
2400	0	25	0.16	0	26	1.14	0	31	0.00	0	38	0.16
4800	0	12	0.16	0	13	-2.48	0	15	0.00	0	19	-2.34
9600	0	6	—	0	6	-2.48	0	7	0.00	0	9	-2.34
19200	0	2	—	0	2	—	0	3	0.00	0	4	-2.34
31250	0	1	0.00	0	1	—	0	1	—	0	2	0.00
38400	0	1	—	0	1	—	0	1	0.00	—	—	—

Bit Rate (bits/s)	$\phi = 3.6864 \text{ MHz}$			$\phi = 4 \text{ MHz}$			$\phi = 4.9152 \text{ MHz}$			$\phi = 5 \text{ MHz}$		
	n	N	Error (%)	n	N	Error (%)	n	N	Error (%)	n	N	Error (%)
110	2	64	0.70	2	70	0.03	2	86	0.31	2	88	-0.25
150	1	191	0.00	1	207	0.16	1	255	0.00	2	64	0.16
300	1	95	0.00	1	103	0.16	1	127	0.00	1	129	0.16
600	0	191	0.00	0	207	0.16	0	255	0.00	1	64	0.16
1200	0	95	0.00	0	103	0.16	0	127	0.00	0	129	0.16
2400	0	47	0.00	0	51	0.16	0	63	0.00	0	64	0.16
4800	0	23	0.00	0	25	0.16	0	31	0.00	0	32	-1.36
9600	0	11	0.00	0	12	0.16	0	15	0.00	0	15	1.73
19200	0	5	0.00	0	6	—	0	7	0.00	0	7	1.73
31250	—	—	—	0	3	0.00	0	4	-1.70	0	4	0.00
38400	0	2	0.00	0	2	—	0	3	0.00	0	3	1.73

Bit Rate (bits/s)	$\phi = 6 \text{ MHz}$			$\phi = 6.144 \text{ MHz}$			$\phi = 7.3728 \text{ MHz}$			$\phi = 8 \text{ MHz}$		
	n	N	Error (%)	n	N	Error (%)	n	N	Error (%)	n	N	Error (%)
110	2	106	-0.44	2	108	0.08	2	130	-0.07	2	141	0.03
150	2	77	0.16	2	79	0.00	2	95	0.00	2	103	0.16
300	1	155	0.16	1	159	0.00	1	191	0.00	1	207	0.16
600	1	77	0.16	1	79	0.00	1	95	0.00	1	103	0.16
1200	0	155	0.16	0	159	0.00	0	191	0.00	0	207	0.16
2400	0	77	0.16	0	79	0.00	0	95	0.00	0	103	0.16
4800	0	38	0.16	0	39	0.00	0	47	0.00	0	51	0.16
9600	0	19	-2.34	0	19	0.00	0	23	0.00	0	25	0.16
19200	0	9	-2.34	0	9	0.00	0	11	0.00	0	12	0.16
31250	0	5	0.00	0	5	2.40	—	—	—	0	7	0.00
38400	0	4	-2.34	0	4	0.00	0	5	0.00	—	—	—

Bit Rate (bits/s)	$\phi = 9.8304 \text{ MHz}$			$\phi = 10 \text{ MHz}$			$\phi = 12 \text{ MHz}$			$\phi = 12.288 \text{ MHz}$		
	n	N	Error (%)	n	N	Error (%)	n	N	Error (%)	n	N	Error (%)
110	2	174	-0.26	2	177	-0.25	2	212	0.03	2	217	0.08
150	2	127	0.00	2	129	0.16	2	155	0.16	2	159	0.00
300	1	255	0.00	2	64	0.16	2	77	0.16	2	79	0.00
600	1	127	0.00	1	129	0.16	1	155	0.16	1	159	0.00
1200	0	255	0.00	1	64	0.16	1	77	0.16	1	79	0.00
2400	0	127	0.00	0	129	0.16	0	155	0.16	0	159	0.00
4800	0	63	0.00	0	64	0.16	0	77	0.16	0	79	0.00
9600	0	31	0.00	0	32	-1.36	0	38	0.16	0	39	0.00
19200	0	15	0.00	0	15	1.73	0	19	-2.34	0	19	0.00
31250	0	9	-1.70	0	9	0.00	0	11	0.00	0	11	2.40
38400	0	7	0.00	0	7	1.73	0	9	-2.34	0	9	0.00

Bit Rate (bits/s)	$\phi = 14 \text{ MHz}$			$\phi = 14.7456 \text{ MHz}$			$\phi = 16 \text{ MHz}$			$\phi = 17.2032 \text{ MHz}$		
	n	N	Error (%)	n	N	Error (%)	n	N	Error (%)	n	N	Error (%)
	110	2	248	-0.17	3	64	0.70	3	70	0.03	3	75
150	2	181	0.16	2	191	0.00	2	207	0.16	2	223	0.00
300	2	90	0.16	2	95	0.00	2	103	0.16	2	111	0.00
600	1	181	0.16	1	191	0.00	1	207	0.16	1	223	0.00
1200	1	90	0.16	1	95	0.00	1	103	0.16	1	111	0.00
2400	0	181	0.16	0	191	0.00	0	207	0.16	0	223	0.00
4800	0	90	0.16	0	95	0.00	0	103	0.16	0	111	0.00
9600	0	45	-0.93	0	47	0.00	0	51	0.16	0	55	0.00
19200	0	22	-0.93	0	23	0.00	0	25	0.16	0	27	0.00
31250	0	13	0.00	0	14	-1.70	0	15	0.00	0	16	1.20
38400	0	10	—	0	11	0.00	0	12	0.16	0	13	0.00

Bit Rate (bits/s)	$\phi = 18 \text{ MHz}$			$\phi = 19.6608 \text{ MHz}$			$\phi = 20 \text{ MHz}$			$\phi = 25 \text{ MHz}$		
	n	N	Error (%)	n	N	Error (%)	n	N	Error (%)	n	N	Error (%)
	110	3	79	-0.12	3	86	0.31	3	88	-0.25	3	110
150	2	233	0.16	2	255	0.00	3	64	0.16	3	80	0.47
300	2	116	0.16	2	127	0.00	2	129	0.16	2	162	-0.15
600	1	233	0.16	1	255	0.00	2	64	0.16	2	80	0.47
1200	1	116	0.16	1	127	0.00	1	129	0.16	1	162	-0.15
2400	0	233	0.16	0	255	0.00	1	64	0.16	1	80	0.47
4800	0	116	0.16	0	127	0.00	0	129	0.16	0	162	-0.15
9600	0	58	-0.69	0	63	0.00	0	64	0.16	0	80	0.47
19200	0	28	1.02	0	31	0.00	0	32	-1.36	0	40	-0.76
31250	0	17	0.00	0	19	-1.70	0	19	0.00	0	24	0.00
38400	0	14	-2.34	0	15	0.00	0	15	1.73	0	19	1.73

Table 12.4 BRR Settings for Various Bit Rates (Synchronous Mode)

Bit Rate (bits/s)	$\phi = 2$ MHz		$\phi = 4$ MHz		$\phi = 8$ MHz		$\phi = 10$ MHz		$\phi = 16$ MHz		$\phi = 20$ MHz		$\phi = 25$ MHz	
	n	N	n	N	n	N	n	N	n	N	n	N	n	N
110	3	70												
250	2	124	2	249	3	124	—	—	3	249				
500	1	249	2	124	2	249	—	—	3	124	—	—		
1 k	1	124	1	249	2	124	—	—	2	249	—	—	3	97
2.5 k	0	199	1	99	1	199	1	249	2	99	2	124	2	155
5 k	0	99	0	199	1	99	1	124	1	199	1	249	2	77
10 k	0	49	0	99	0	199	0	249	1	99	1	124	1	155
25 k	0	19	0	39	0	79	0	99	0	159	0	199	0	249
50 k	0	9	0	19	0	39	0	49	0	79	0	99	0	124
100 k	0	4	0	9	0	19	0	24	0	39	0	49	0	62
250 k	0	1	0	3	0	7	0	9	0	15	0	19	0	24
500 k	0	0*	0	1	0	3	0	4	0	7	0	9	—	—
1 M			0	0*	0	1			0	3	0	4	—	—
2.5 M							0	0*			0	1	—	—
5 M											0	0*	—	—

Legend:

Blank : Cannot be set.

— : Can be set, but there will be a degree of error.

* : Continuous transfer is not possible.

Note: As far as possible, the setting should be made so that the error is no more than 1%.

The BRR setting is found from the following formulas.

Asynchronous mode:

$$N = \frac{\phi}{64 \times 2^{2n-1} \times B} \times 10^6 - 1$$

Synchronous mode:

$$N = \frac{\phi}{8 \times 2^{2n-1} \times B} \times 10^6 - 1$$

Where B: Bit rate (bits/s)

N: BRR setting for baud rate generator ($0 \leq N \leq 255$)

ϕ : Operating frequency (MHz)

n: Baud rate generator input clock (n = 0 to 3)

(See the table below for the relation between n and the clock.)

n	Clock	SMR Setting	
		CKS1	CKS0
0	ϕ	0	0
1	$\phi/4$	0	1
2	$\phi/16$	1	0
3	$\phi/64$	1	1

The bit rate error in asynchronous mode is found from the following formula:

$$\text{Error (\%)} = \left\{ \frac{\phi \times 10^6}{(N + 1) \times B \times 64 \times 2^{2n-1}} - 1 \right\} \times 100$$

Table 12.5 shows the maximum bit rate for each frequency in asynchronous mode. Tables 12.6 and 12.7 show the maximum bit rates with external clock input.

Table 12.5 Maximum Bit Rate for Each Frequency (Asynchronous Mode)

ϕ (MHz)	Maximum Bit Rate (bits/s)	n	N
2	62500	0	0
2.097152	65536	0	0
2.4576	76800	0	0
3	93750	0	0
3.6864	115200	0	0
4	125000	0	0
4.9152	153600	0	0
5	156250	0	0
6	187500	0	0
6.144	192000	0	0
7.3728	230400	0	0
8	250000	0	0
9.8304	307200	0	0
10	312500	0	0
12	375000	0	0
12.288	384000	0	0
14	437500	0	0
14.7456	460800	0	0
16	500000	0	0
17.2032	537600	0	0
18	562500	0	0
19.6608	614400	0	0
20	625000	0	0
25	781250	0	0

Table 12.6 Maximum Bit Rate with External Clock Input (Asynchronous Mode)

ϕ (MHz)	External Input Clock (MHz)	Maximum Bit Rate (bits/s)
2	0.5000	31250
2.097152	0.5243	32768
2.4576	0.6144	38400
3	0.7500	46875
3.6864	0.9216	57600
4	1.0000	62500
4.9152	1.2288	76800
5	1.2500	78125
6	1.5000	93750
6.144	1.5360	96000
7.3728	1.8432	115200
8	2.0000	125000
9.8304	2.4576	153600
10	2.5000	156250
12	3.0000	187500
12.288	3.0720	192000
14	3.5000	218750
14.7456	3.6864	230400
16	4.0000	250000
17.2032	4.3008	268800
18	4.5000	281250
19.6608	4.9152	307200
20	5.0000	312500
25	6.2500	390625

Table 12.7 Maximum Bit Rate with External Clock Input (Synchronous Mode)

ϕ (MHz)	External Input Clock (MHz)	Maximum Bit Rate (bits/s)
2	0.3333	333333.3
4	0.6667	666666.7
6	1.0000	1000000.0
8	1.3333	1333333.3
10	1.6667	1666666.7
12	2.0000	2000000.0
14	2.3333	2333333.3
16	2.6667	2666666.7
18	3.0000	3000000.0
20	3.3333	3333333.3
25	4.1667	4166666.7

12.2.9 Smart Card Mode Register (SCMR)

Bit	:	7	6	5	4	3	2	1	0
		—	—	—	—	SDIR	SINV	—	SMIF
Initial value :		1	1	1	1	0	0	1	0
R/W	:	—	—	—	—	R/W	R/W	—	R/W

SCMR selects LSB-first or MSB-first transfer by means of bit SDIR. Except in the case of asynchronous mode 7-bit data, LSB-first or MSB-first transfer can be selected regardless of the serial communication mode. The descriptions in this chapter refer to LSB-first transfer.

For details of the other bits in SCMR, see section 13.2.1, Smart Card Mode Register (SCMR).

SCMR is initialized to H'F2 by a reset and in hardware standby mode. In software standby mode and module stop mode it retains its previous state.

Bits 7 to 4—Reserved: These bits cannot be modified and are always read as 1.

Bit 3—Smart Card Data Transfer Direction (SDIR): Selects the serial/parallel conversion format.

This bit is valid when 8-bit data is used as the transmit/receive format.

Bit 3

SDIR	Description	
0	TDR contents are transmitted LSB-first Receive data is stored in RDR LSB-first	(Initial value)
1	TDR contents are transmitted MSB-first Receive data is stored in RDR MSB-first	

Bit 2—Smart Card Data Invert (SINV): Specifies inversion of the data logic level. The SINV bit does not affect the logic level of the parity bit(s); parity bit inversion requires inversion of the O/\bar{E} bit in SMR.

Bit 2

SINV	Description	
0	TDR contents are transmitted without modification Receive data is stored in RDR without modification	(Initial value)
1	TDR contents are inverted before being transmitted Receive data is stored in RDR in inverted form	

Bit 1—Reserved: This bit cannot be modified and is always read as 1.

Bit 0—Smart Card Interface Mode Select (SMIF): When the smart card interface operates as a normal SCI, 0 should be written to this bit.

Bit 0

SMIF	Description	
0	Operates as normal SCI (smart card interface function disabled)	(Initial value)
1	Smart card interface function enabled	

12.2.10 Module Stop Control Register (MSTPCR)

MSTPCRH								MSTPCRL									
Bit	:	15	14	13	12	11	10	9	8	7	6	5	4	3	2	1	0
Initial value	:	0	0	1	1	1	1	1	1	1	1	1	1	1	1	1	1
R/W	:	R/W	R/W	R/W	R/W	R/W	R/W	R/W	R/W	R/W	R/W	R/W	R/W	R/W	R/W	R/W	R/W

MSTPCR is a 16-bit readable/writable register that performs module stop mode control.

When the corresponding bit of bits MSTP6 to MSTP5 is set to 1, SCI operation stops at the end of the bus cycle and a transition is made to module stop mode. Registers cannot be read or written to in module stop mode. For details, see section 19.5, Module Stop Mode.

MSTPCR is initialized to H'3FFF by a reset and in hardware standby mode. It is not initialized in software standby mode.

Bit 6—Module Stop (MSTP6): Specifies the SCI channel 1 module stop mode.

Bit 6

MSTP6	Description
0	SCI channel 1 module stop mode cleared
1	SCI channel 1 module stop mode set (Initial value)

Bit 5—Module Stop (MSTP5): Specifies the SCI channel 0 module stop mode.

Bit 5

MSTP5	Description
0	SCI channel 0 module stop mode cleared
1	SCI channel 0 module stop mode set (Initial value)

12.3 Operation

12.3.1 Overview

The SCI can carry out serial communication in two modes: asynchronous mode in which synchronization is achieved character by character, and synchronous mode in which synchronization is achieved with clock pulses.

Selection of asynchronous or synchronous mode and the transmission format is made using SMR as shown in table 12.8. The SCI clock is determined by a combination of the C/\bar{A} bit in SMR and the CKE1 and CKE0 bits in SCR, as shown in table 12.9.

Asynchronous Mode

- Data length: Choice of 7 or 8 bits
- Choice of parity addition, multiprocessor bit addition, and addition of 1 or 2 stop bits (the combination of these parameters determines the transfer format and character length)
- Detection of framing, parity, and overrun errors, and breaks, during reception
- Choice of internal or external clock as SCI clock source
 - When internal clock is selected:

The SCI operates on the baud rate generator clock and a clock with the same frequency as the bit rate can be output
 - When external clock is selected:

A clock with a frequency of 16 times the bit rate must be input (the built-in baud rate generator is not used)

Synchronous Mode

- Transfer format: Fixed 8-bit data
- Detection of overrun errors during reception
- Choice of internal or external clock as SCI clock source
 - When internal clock is selected:

The SCI operates on the baud rate generator clock and a serial clock is output off-chip
 - When external clock is selected:

The built-in baud rate generator is not used, and the SCI operates on the input serial clock

Table 12.8 SMR Settings and Serial Transfer Format Selection

SMR Settings					SCI Transfer Format					
Bit 7	Bit 6	Bit 2	Bit 5	Bit 3	Mode	Data Length	Multi-processor Bit	Parity Bit	Stop Bit Length	
C/ \bar{A}	CHR	MP	PE	STOP						
0	0	0	0	0	Asynchronous mode	8-bit data	No	No	1 bit	
				1					2 bits	
				0					1 bit	
				1					2 bits	
	1	0	0	0	Asynchronous mode (multi-processor format)	7-bit data	No	No	1 bit	
									1	2 bits
									0	1 bit
									1	2 bits
0	1	—	0	Asynchronous mode (multi-processor format)	8-bit data	Yes	No	1 bit		
								1	2 bits	
								0	1 bit	
								1	2 bits	
1	—	—	—	—	Synchronous mode	8-bit data	No	None		

Table 12.9 SMR and SCR Settings and SCI Clock Source Selection

SMR	SCR Settings			SCI Transmit/Receive Clock		
Bit 7	Bit 1	Bit 0	Mode	Clock Source	SCK Pin Function	
C/ \bar{A}	CKE1	CKE0				
0	0	0	Asynchronous mode	Internal	SCI does not use SCK pin	
		1			Outputs clock with same frequency as bit rate	
		0			External	Inputs clock with frequency of 16 times the bit rate
		1				
1	0	0	Synchronous mode	Internal	Outputs serial clock	
		1				
		0			External	Inputs serial clock
		1				

12.3.2 Operation in Asynchronous Mode

In asynchronous mode, characters are sent or received, each preceded by a start bit indicating the start of communication and one or two stop bits indicating the end of communication. Serial communication is thus carried out with synchronization established on a character-by-character basis.

Inside the SCI, the transmitter and receiver are independent units, enabling full-duplex communication. Both the transmitter and the receiver also have a double-buffered structure, so that data can be read or written during transmission or reception, enabling continuous data transfer.

Figure 12.2 shows the general format for asynchronous serial communication.

In asynchronous serial communication, the communication line is usually held in the mark state (high level). The SCI monitors the communication line, and when it goes to the space state (low level), recognizes a start bit and starts serial communication.

One serial communication character consists of a start bit (low level), followed by data (in LSB-first order), a parity bit (high or low level), and finally one or two stop bits (high level).

In asynchronous mode, the SCI performs synchronization at the falling edge of the start bit in reception. The SCI samples the data on the 8th pulse of a clock with a frequency of 16 times the length of one bit, so that the transfer data is latched at the center of each bit.

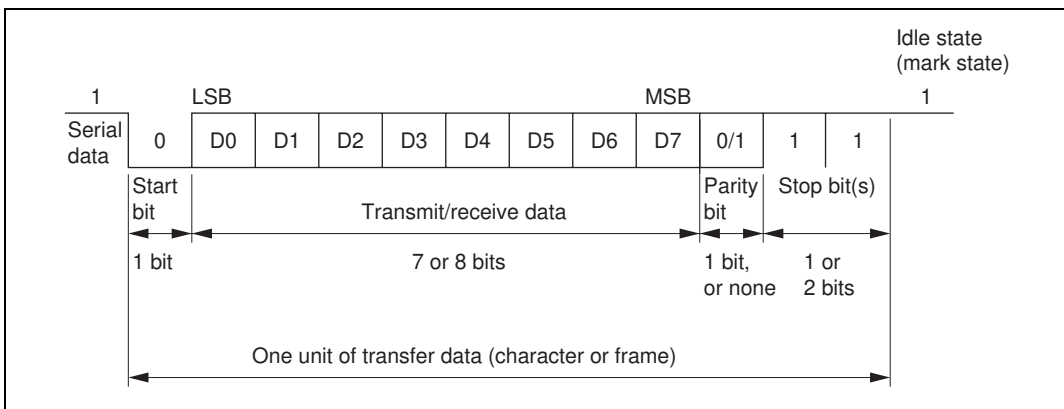

**Figure 12.2 Data Format in Asynchronous Communication
(Example with 8-Bit Data, Parity, Two Stop Bits)**

Data Transfer Format

Table 12.10 shows the data transfer formats that can be used in asynchronous mode. Any of 12 transfer formats can be selected according to the SMR setting.

Table 12.10 Serial Transfer Formats (Asynchronous Mode)

SMR Settings				Serial Transfer Format and Frame Length												
CHR	PE	MP	STOP	1	2	3	4	5	6	7	8	9	10	11	12	
0	0	0	0	S	8-bit data								STOP			
0	0	0	1	S	8-bit data								STOP	STOP		
0	1	0	0	S	8-bit data								P	STOP		
0	1	0	1	S	8-bit data								P	STOP	STOP	
1	0	0	0	S	7-bit data							STOP				
1	0	0	1	S	7-bit data							STOP	STOP			
1	1	0	0	S	7-bit data							P	STOP			
1	1	0	1	S	7-bit data							P	STOP	STOP		
0	—	1	0	S	8-bit data								MPB	STOP		
0	—	1	1	S	8-bit data								MPB	STOP	STOP	
1	—	1	0	S	7-bit data							MPB	STOP			
1	—	1	1	S	7-bit data							MPB	STOP	STOP		

Legend:

S: Start bit

STOP: Stop bit

P: Parity bit

MPB: Multiprocessor bit

Clock

Either an internal clock generated by the built-in baud rate generator or an external clock input at the SCK pin can be selected as the SCI's serial clock, according to the setting of the C/A bit in SMR and the CKE1 and CKE0 bits in SCR. For details of SCI clock source selection, see table 12.9.

When an external clock is input at the SCK pin, the clock frequency should be 16 times the bit rate used.

When the SCI is operated on an internal clock, the clock can be output from the SCK pin. The frequency of the clock output in this case is equal to the bit rate, and the phase is such that the rising edge of the clock is at the center of each transmit data bit, as shown in figure 12.3.

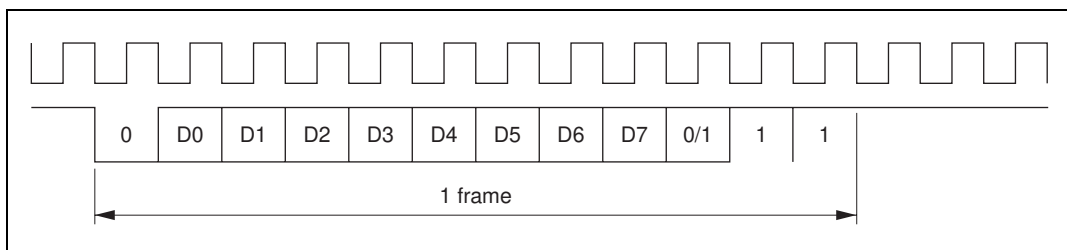

Figure 12.3 Relation between Output Clock and Transfer Data Phase (Asynchronous Mode)

Data Transfer Operations

SCI initialization (asynchronous mode): Before transmitting or receiving data, first clear the TE and RE bits in SCR to 0, then initialize the SCI as described below.

When the operating mode, transfer format, etc., is changed, the TE and RE bits must be cleared to 0 before making the change using the following procedure. When the TE bit is cleared to 0, the TDRE flag is set to 1 and TSR is initialized. Note that clearing the RE bit to 0 does not change the contents of the RDRF, PER, FER, and ORER flags, or the contents of RDR.

When an external clock is used the clock should not be stopped during operation, including initialization, since operation will be unreliable in this case.

Figure 12.4 shows a sample SCI initialization flowchart.

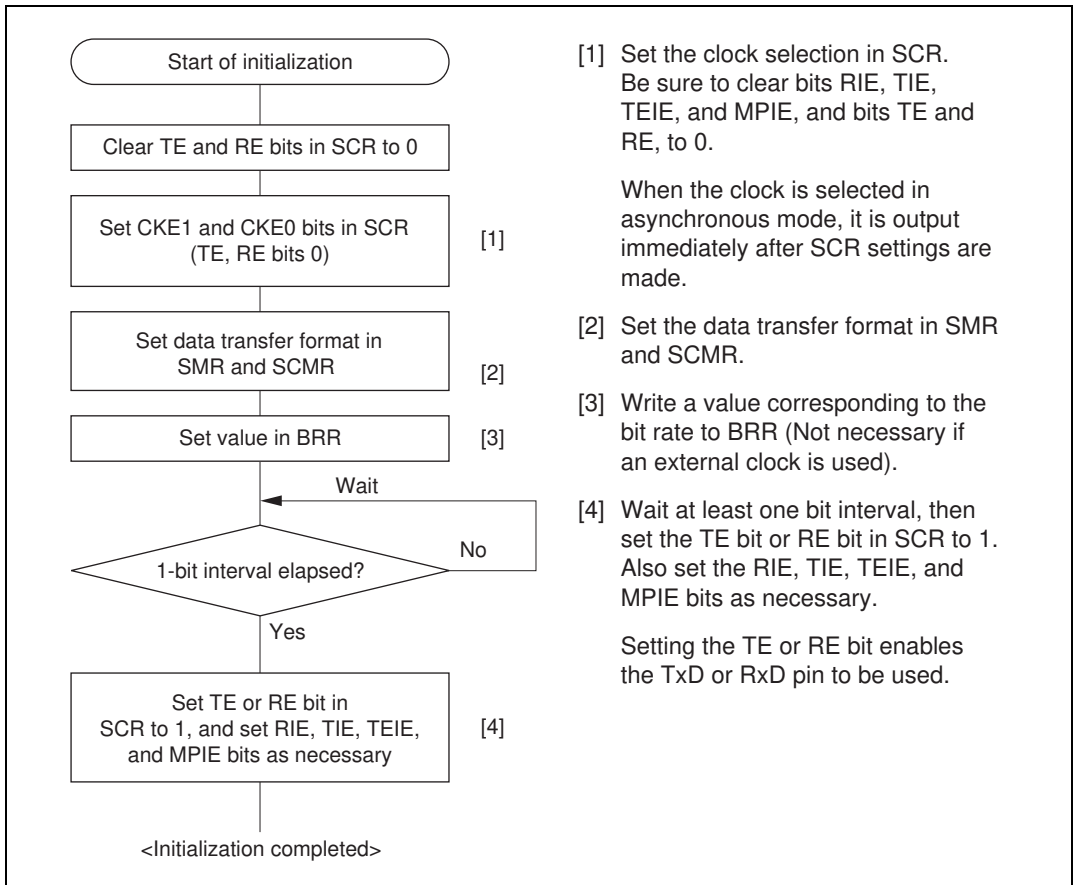

Figure 12.4 Sample SCI Initialization Flowchart

Serial data transmission (asynchronous mode): Figure 12.5 shows a sample flowchart for serial transmission.

The following procedure should be used for serial data transmission.

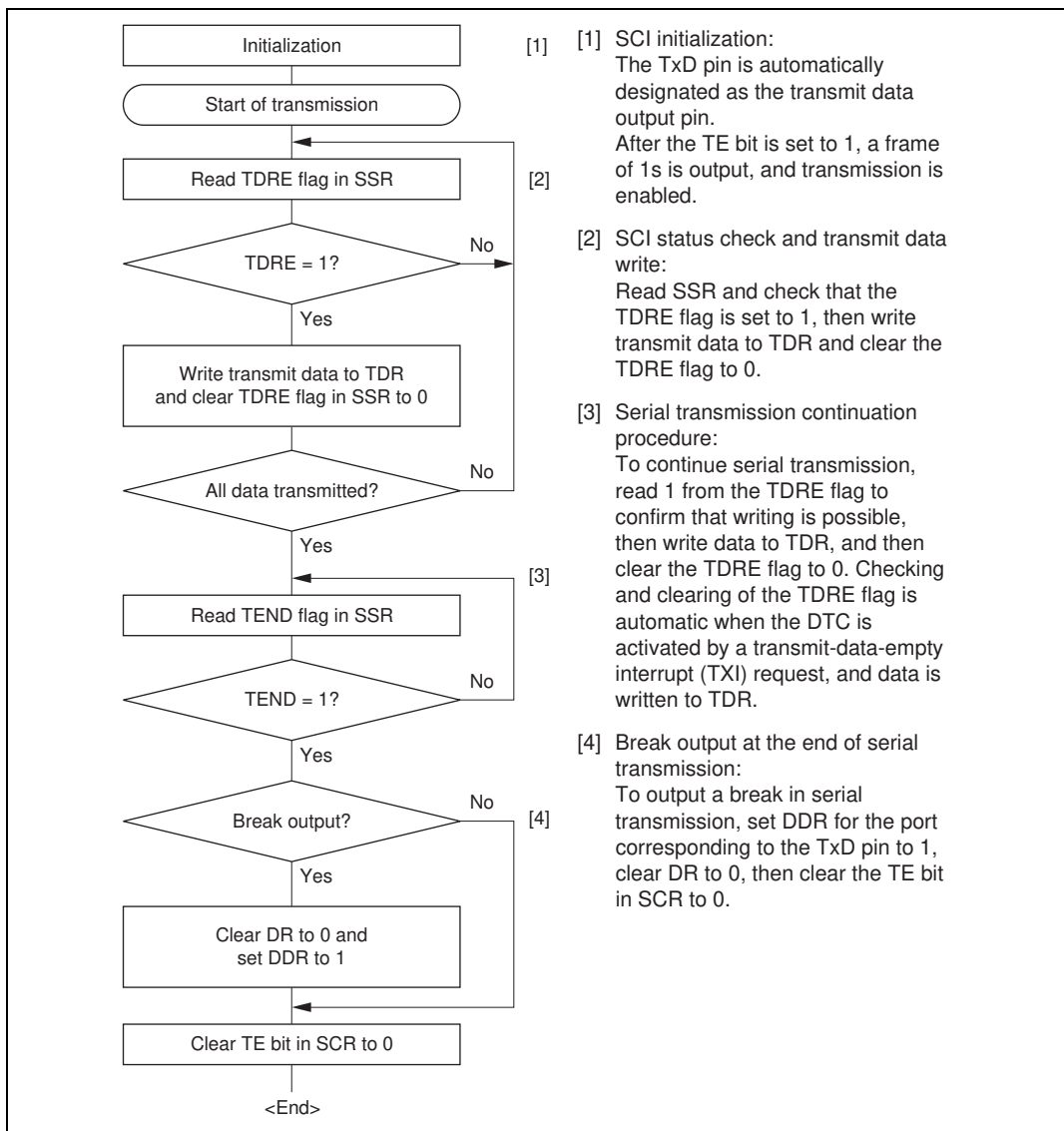

Figure 12.5 Sample Serial Transmission Flowchart

In serial transmission, the SCI operates as described below.

[1] The SCI monitors the TDRE flag in SSR, and if it is 0, recognizes that data has been written to TDR, and transfers the data from TDR to TSR.

[2] After transferring data from TDR to TSR, the SCI sets the TDRE flag to 1 and starts transmission.

If the TIE bit is set to 1 at this time, a transmit-data-empty interrupt (TXI) is generated.

The serial transmit data is sent from the TxD pin in the following order.

[a] Start bit:

One 0-bit is output.

[b] Transmit data:

8-bit or 7-bit data is output in LSB-first order.

[c] Parity bit or multiprocessor bit:

One parity bit (even or odd parity), or one multiprocessor bit is output.

A format in which neither a parity bit nor a multiprocessor bit is output can also be selected.

[d] Stop bit(s):

One or two 1-bits (stop bits) are output.

[e] Mark state:

1 is output continuously until the start bit that starts the next transmission is sent.

[3] The SCI checks the TDRE flag at the timing for sending the stop bit.

If the TDRE flag is cleared to 0, the data is transferred from TDR to TSR, the stop bit is sent, and then serial transmission of the next frame is started.

If the TDRE flag is set to 1, the TEND flag in SSR is set to 1, the stop bit is sent, and then the mark state is entered in which 1 is output continuously. If the TEIE bit in SCR is set to 1 at this time, a TEI interrupt request is generated.

Figure 12.6 shows an example of the operation for transmission in asynchronous mode.

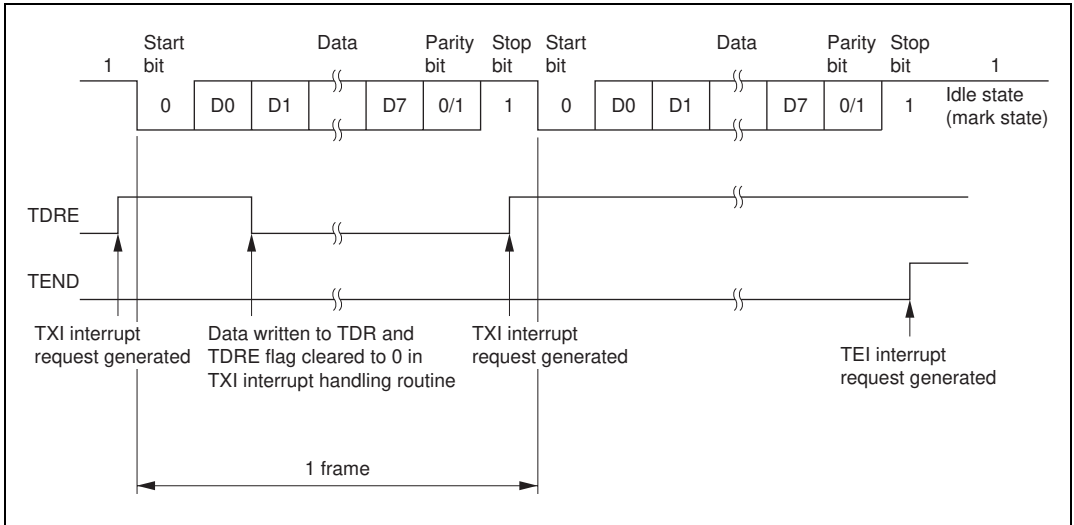

**Figure 12.6 Example of Transmit Operation in Asynchronous Mode
(Example with 8-Bit Data, Parity, One Stop Bit)**

Serial data reception (asynchronous mode): Figure 12.7 shows a sample flowchart for serial reception.

The following procedure should be used for serial data reception.

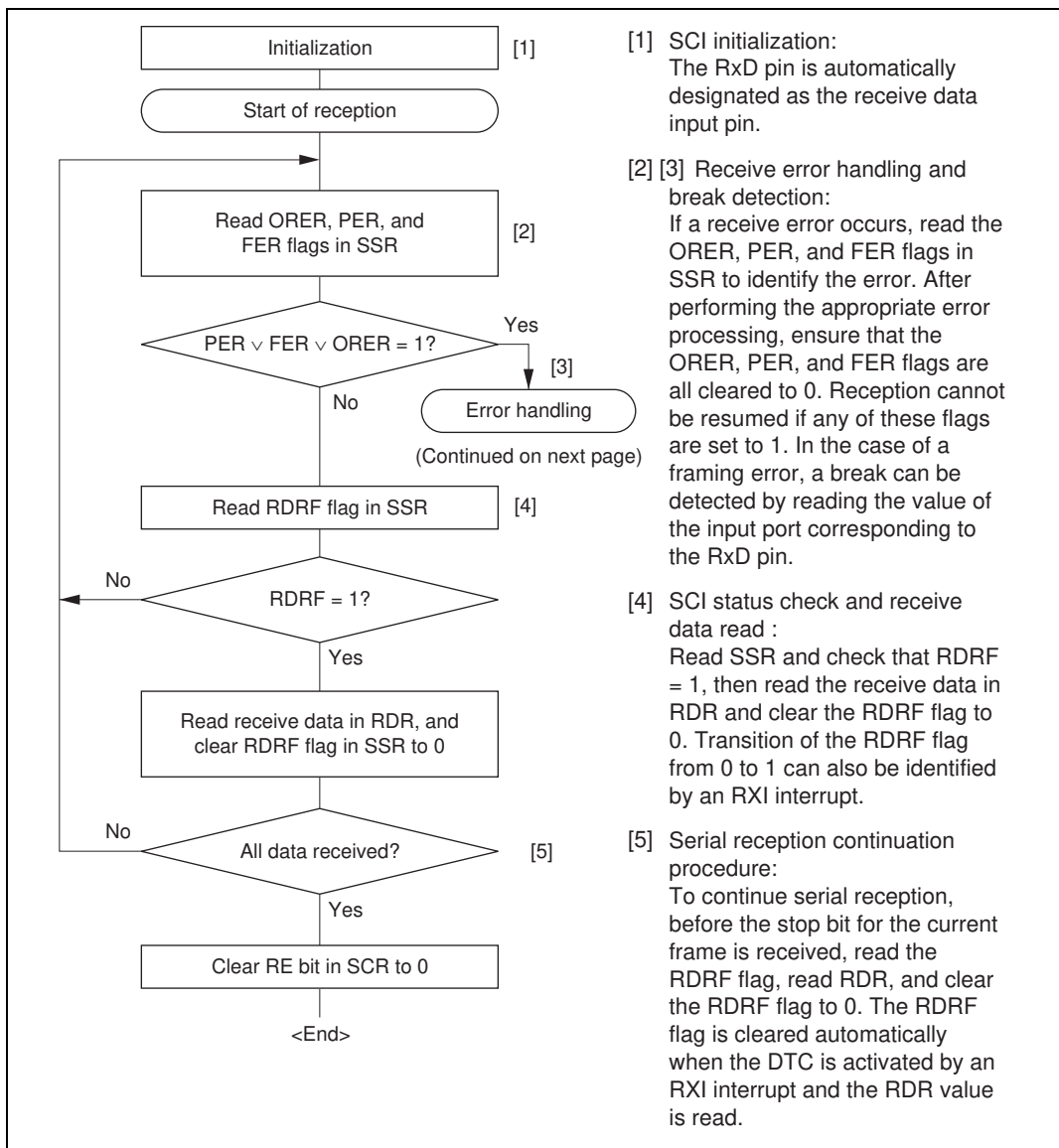

Figure 12.7 Sample Serial Reception Flowchart

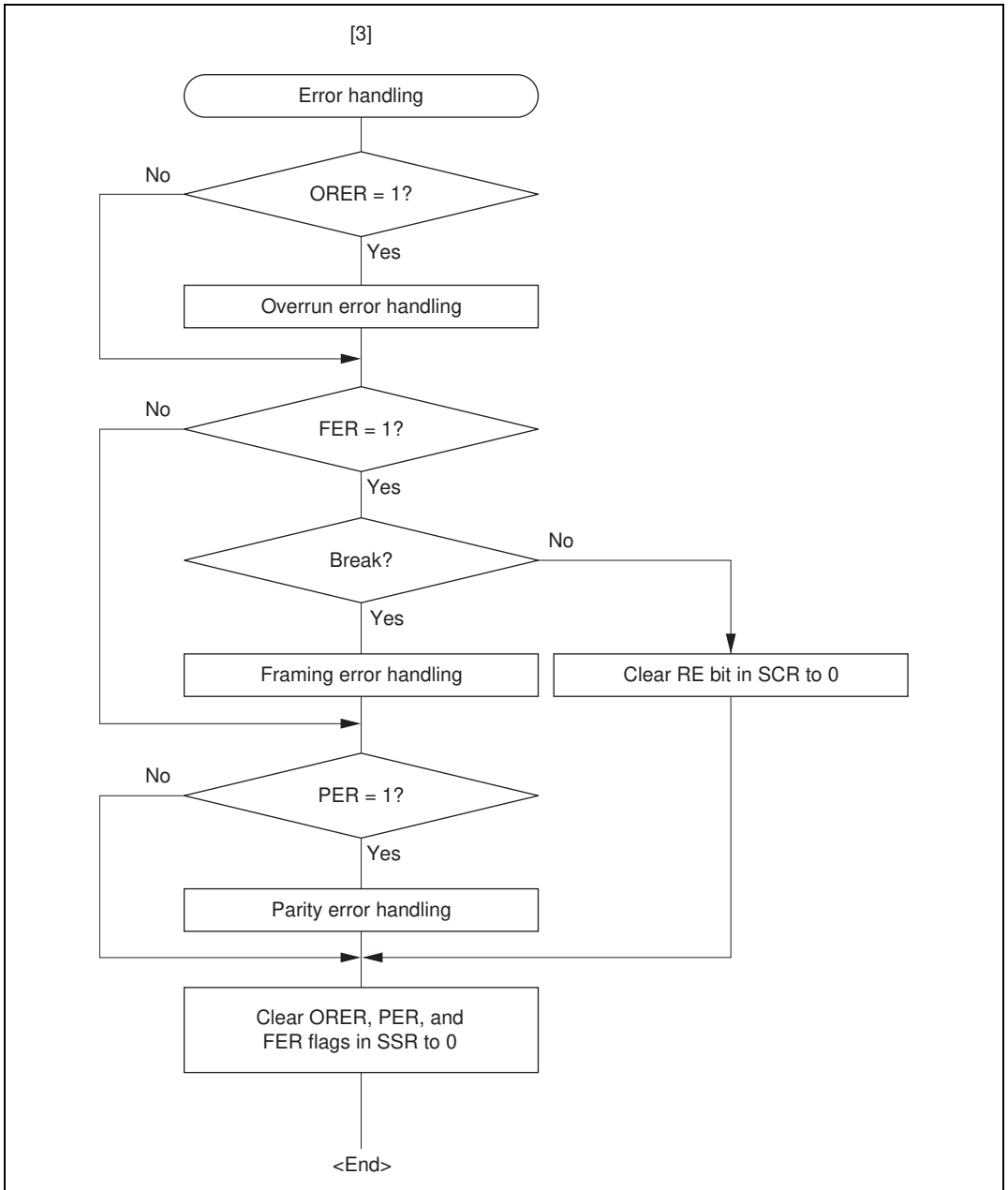

Figure 12.7 Sample Serial Reception Flowchart (cont)

In serial reception, the SCI operates as described below.

[1] The SCI monitors the communication line, and if a 0 stop bit is detected, performs internal synchronization and starts reception.

[2] The received data is stored in RSR in LSB-to-MSB order.

[3] The parity bit and stop bit are received.

After receiving these bits, the SCI carries out the following checks.

[a] Parity check:

The SCI checks whether the number of 1 bits in the receive data agrees with the parity (even or odd) set in the O/\bar{E} bit in SMR.

[b] Stop bit check:

The SCI checks whether the stop bit is 1.

If there are two stop bits, only the first is checked.

[c] Status check:

The SCI checks whether the RDRF flag is 0, indicating that the receive data can be transferred from RSR to RDR.

If all the above checks are passed, the RDRF flag is set to 1, and the receive data is stored in RDR.

If a receive error* is detected in the error check, the operation is as shown in table 12.11.

Note: * Subsequent receive operations cannot be performed when a receive error has occurred.

Also note that the RDRF flag is not set to 1 in reception, and so the error flags must be cleared to 0.

[4] If the RIE bit in SCR is set to 1 when the RDRF flag changes to 1, a receive-data-full interrupt (RXI) request is generated.

Also, if the RIE bit in SCR is set to 1 when the ORER, PER, or FER flag changes to 1, a receive-error interrupt (ERI) request is generated.

Table 12.11 Receive Error Conditions

Receive Error	Abbreviation	Condition	Data Transfer
Overrun error	ORER	When the next data reception is completed while the RDRF flag in SSR is set to 1	Receive data is not transferred from RSR to RDR
Framing error	FER	When the stop bit is 0	Receive data is transferred from RSR to RDR
Parity error	PER	When the received data differs from the parity (even or odd) set in SMR	Receive data is transferred from RSR to RDR

Figure 12.8 shows an example of the operation for reception in asynchronous mode.

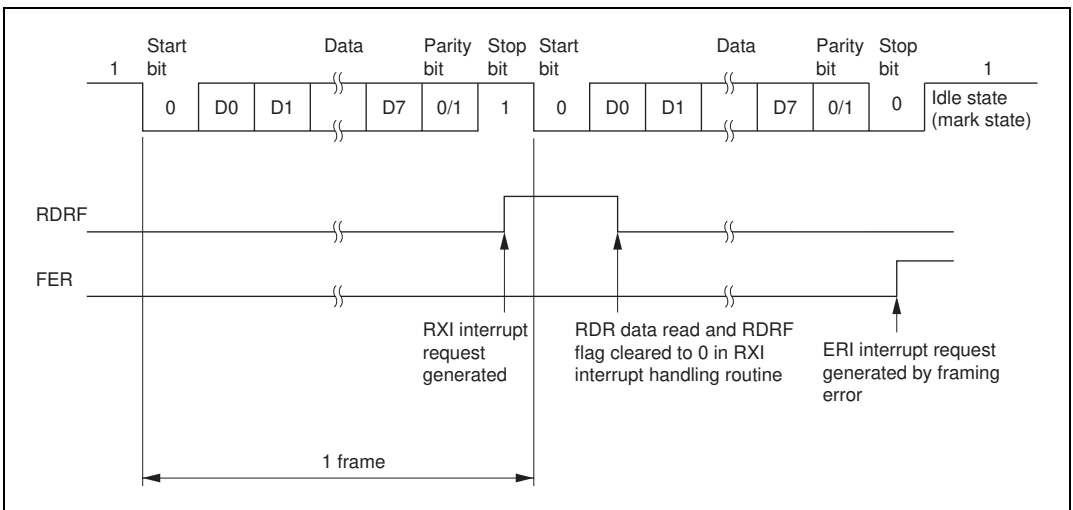

**Figure 12.8 Example of SCI Receive Operation
(Example with 8-Bit Data, Parity, One Stop Bit)**

12.3.3 Multiprocessor Communication Function

The multiprocessor communication function performs serial communication using the multiprocessor format, in which a multiprocessor bit is added to the transfer data, in asynchronous mode. Use of this function enables data transfer to be performed among a number of processors sharing a single serial communication line.

When multiprocessor communication is carried out, each receiving station is addressed by a unique ID code.

The serial communication cycle consists of two component cycles: an ID transmission cycle which specifies the receiving station, and a data transmission cycle. The multiprocessor bit is used to differentiate between the ID transmission cycle and the data transmission cycle.

The transmitting station first sends the ID of the receiving station with which it wants to perform serial communication as data with a 1 multiprocessor bit added. It then sends transmit data as data with a 0 multiprocessor bit added.

The receiving station skips the data until data with a 1 multiprocessor bit is sent.

When data with a 1 multiprocessor bit is received, the receiving station compares that data with its own ID. The station whose ID matches then receives the data sent next. Stations whose ID does not match continue to skip the data until data with a 1 multiprocessor bit is again received. In this way, data communication is carried out among a number of processors.

Figure 12.9 shows an example of inter-processor communication using the multiprocessor format.

Data Transfer Formats

There are four data transfer formats.

When the multiprocessor format is specified, the parity bit specification is invalid.

For details, see table 12.10.

Clock

See the section on asynchronous mode.

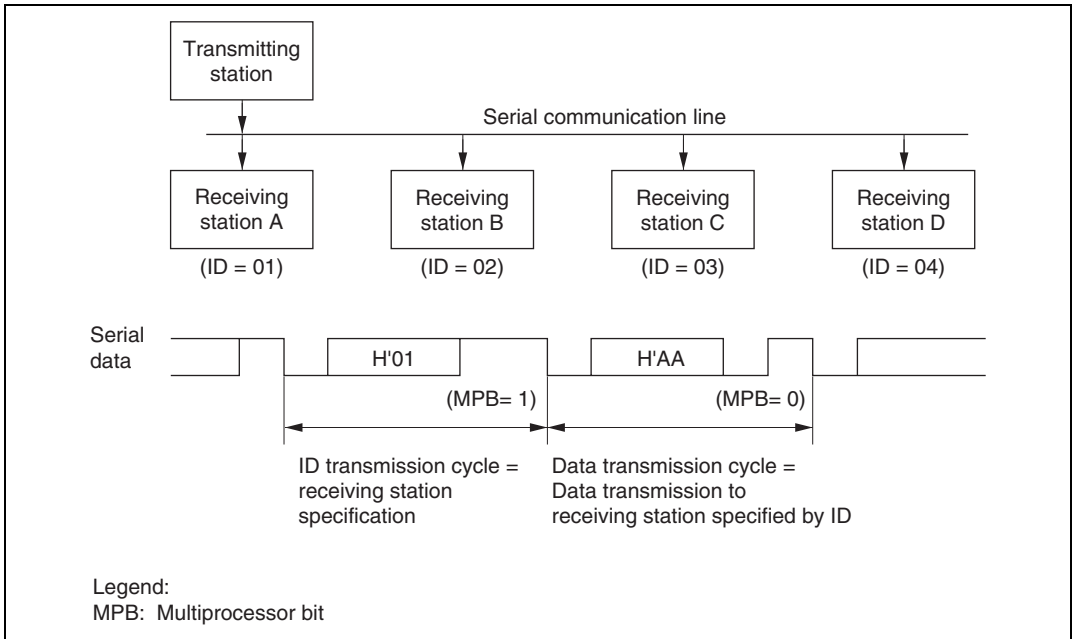

Figure 12.9 Example of Inter-Processor Communication Using Multiprocessor Format (Transmission of Data H'AA to Receiving Station A)

Data Transfer Operations

Multiprocessor serial data transmission: Figure 12.10 shows a sample flowchart for multiprocessor serial data transmission.

The following procedure should be used for multiprocessor serial data transmission.

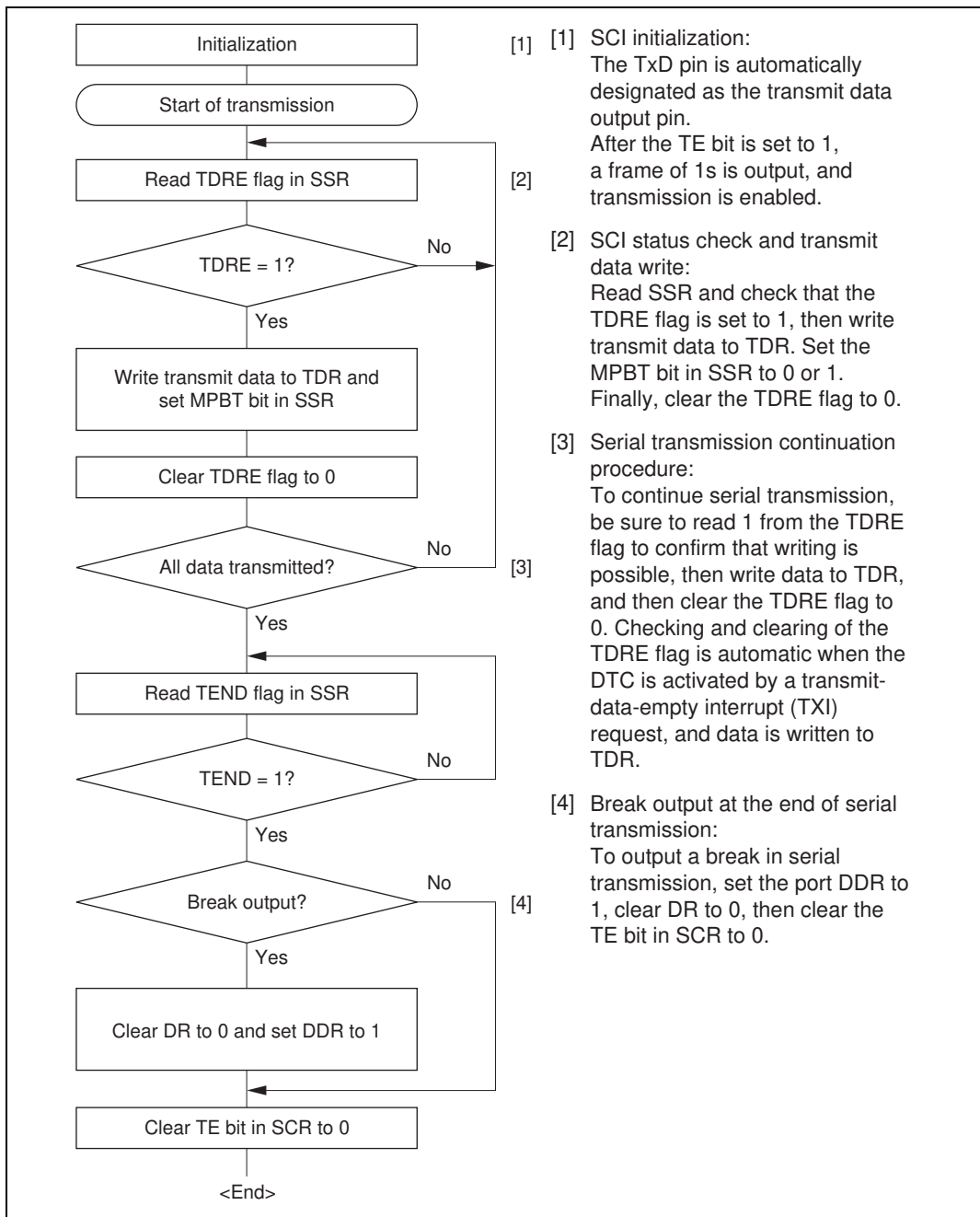

Figure 12.10 Sample Multiprocessor Serial Transmission Flowchart

In serial transmission, the SCI operates as described below.

[1] The SCI monitors the TDRE flag in SSR, and if it is 0, recognizes that data has been written to TDR, and transfers the data from TDR to TSR.

[2] After transferring data from TDR to TSR, the SCI sets the TDRE flag to 1 and starts transmission.

If the TIE bit is set to 1 at this time, a transmit-data-empty interrupt (TXI) is generated.

The serial transmit data is sent from the TxD pin in the following order.

[a] Start bit:

One 0-bit is output.

[b] Transmit data:

8-bit or 7-bit data is output in LSB-first order.

[c] Multiprocessor bit

One multiprocessor bit (MPBT value) is output.

[d] Stop bit(s):

One or two 1-bits (stop bits) are output.

[e] Mark state:

1 is output continuously until the start bit that starts the next transmission is sent.

[3] The SCI checks the TDRE flag at the timing for sending the stop bit.

If the TDRE flag is cleared to 0, data is transferred from TDR to TSR, the stop bit is sent, and then serial transmission of the next frame is started.

If the TDRE flag is set to 1, the TEND flag in SSR is set to 1, the stop bit is sent, and then the mark state is entered in which 1 is output continuously. If the TEIE bit in SCR is set to 1 at this time, a transmit-end interrupt (TEI) request is generated.

Figure 12.11 shows an example of SCI operation for transmission using the multiprocessor format.

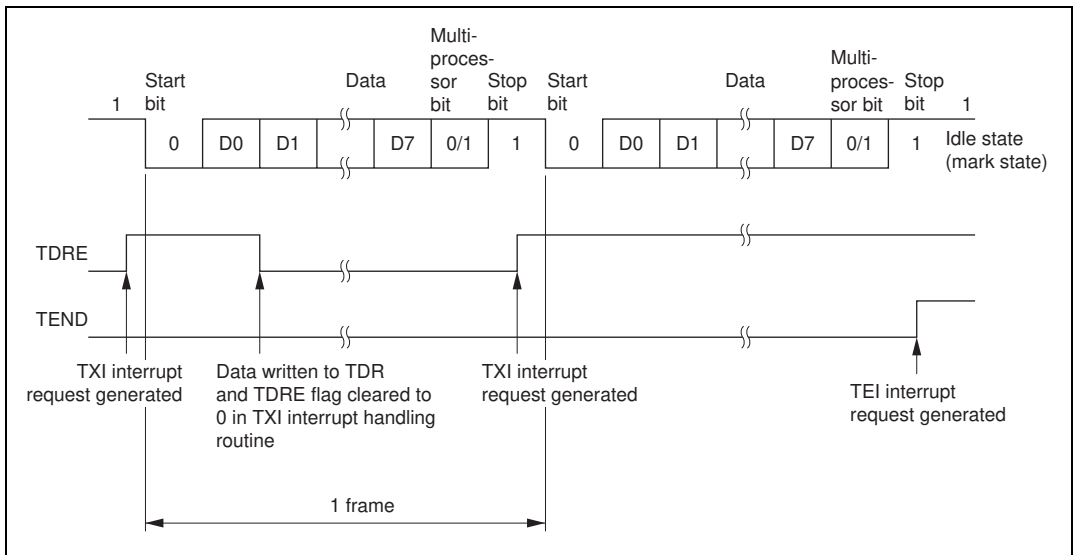

**Figure 12.11 Example of SCI Transmit Operation
(Example with 8-Bit Data, Multiprocessor Bit, One Stop Bit)**

Multiprocessor serial data reception: Figure 12.12 shows a sample flowchart for multiprocessor serial reception.

The following procedure should be used for multiprocessor serial data reception.

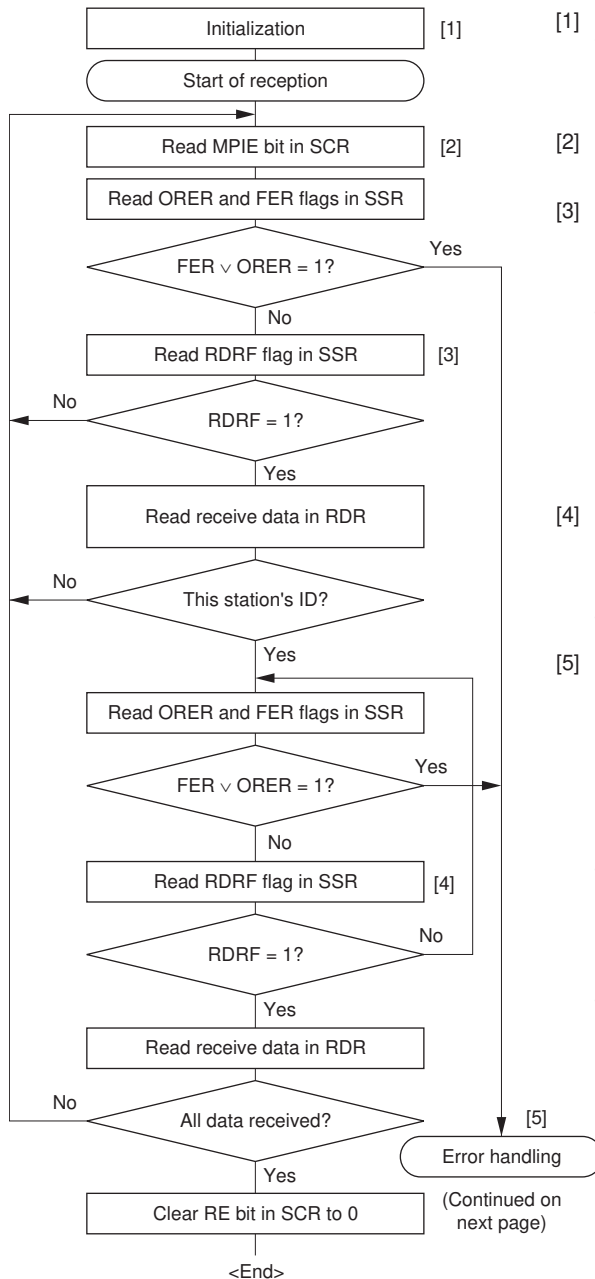

[1] SCI initialization:
The RxD pin is automatically designated as the receive data input pin.

[2] ID reception cycle:
Set the MPIE bit in SCR to 1.

[3] SCI status check, ID reception and comparison:
Read SSR and check that the RDRF flag is set to 1, then read the receive data in RDR and compare it with this station's ID. If the data is not this station's ID, set the MPIE bit to 1 again, and clear the RDRF flag to 0. If the data is this station's ID, clear the RDRF flag to 0.

[4] SCI status check and data reception:
Read SSR and check that the RDRF flag is set to 1, then read the data in RDR.

[5] Receive error handling and break detection:
If a receive error occurs, read the ORER and FER flags in SSR to identify the error. After performing the appropriate error handling, ensure that the ORER and FER flags are both cleared to 0. Reception cannot be resumed if either of these flags is set to 1. In the case of a framing error, a break can be detected by reading the RxD pin value.

(Continued on next page)

Figure 12.12 Sample Multiprocessor Serial Reception Flowchart

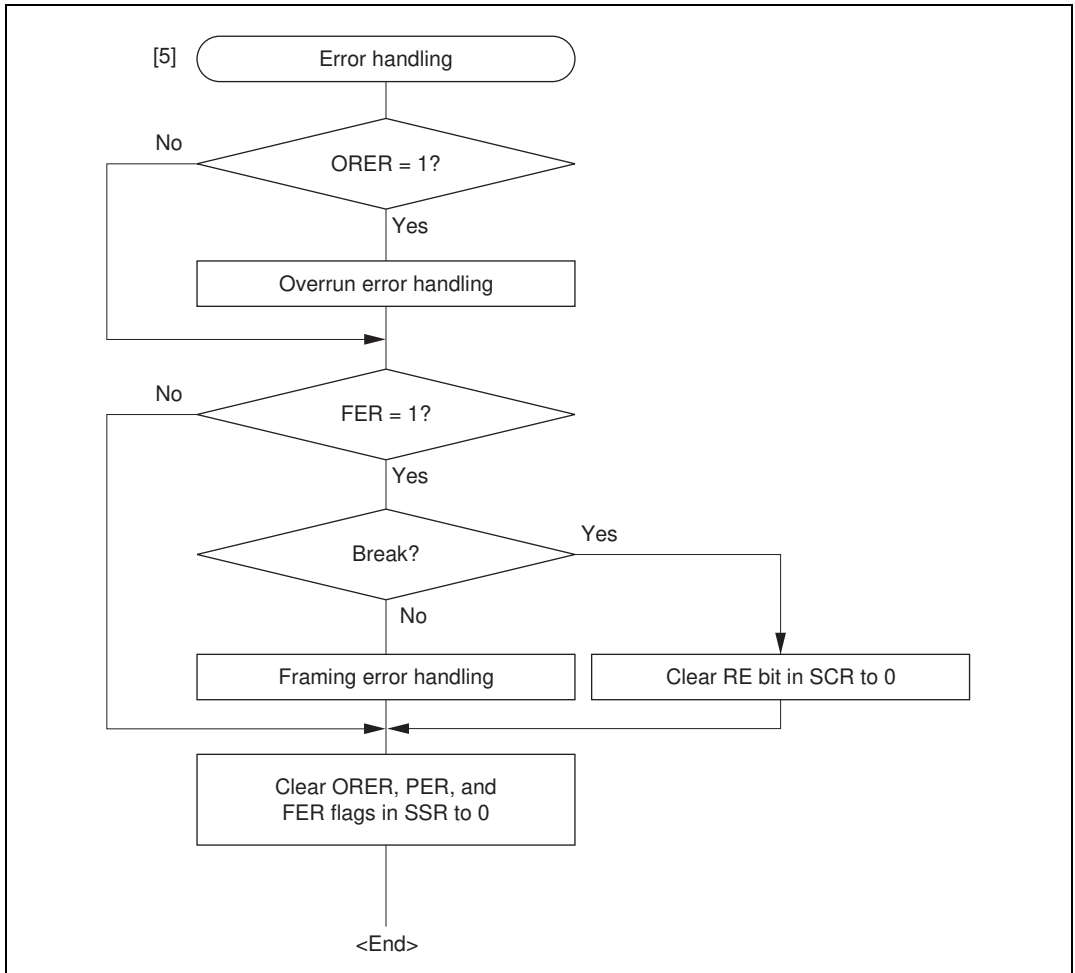
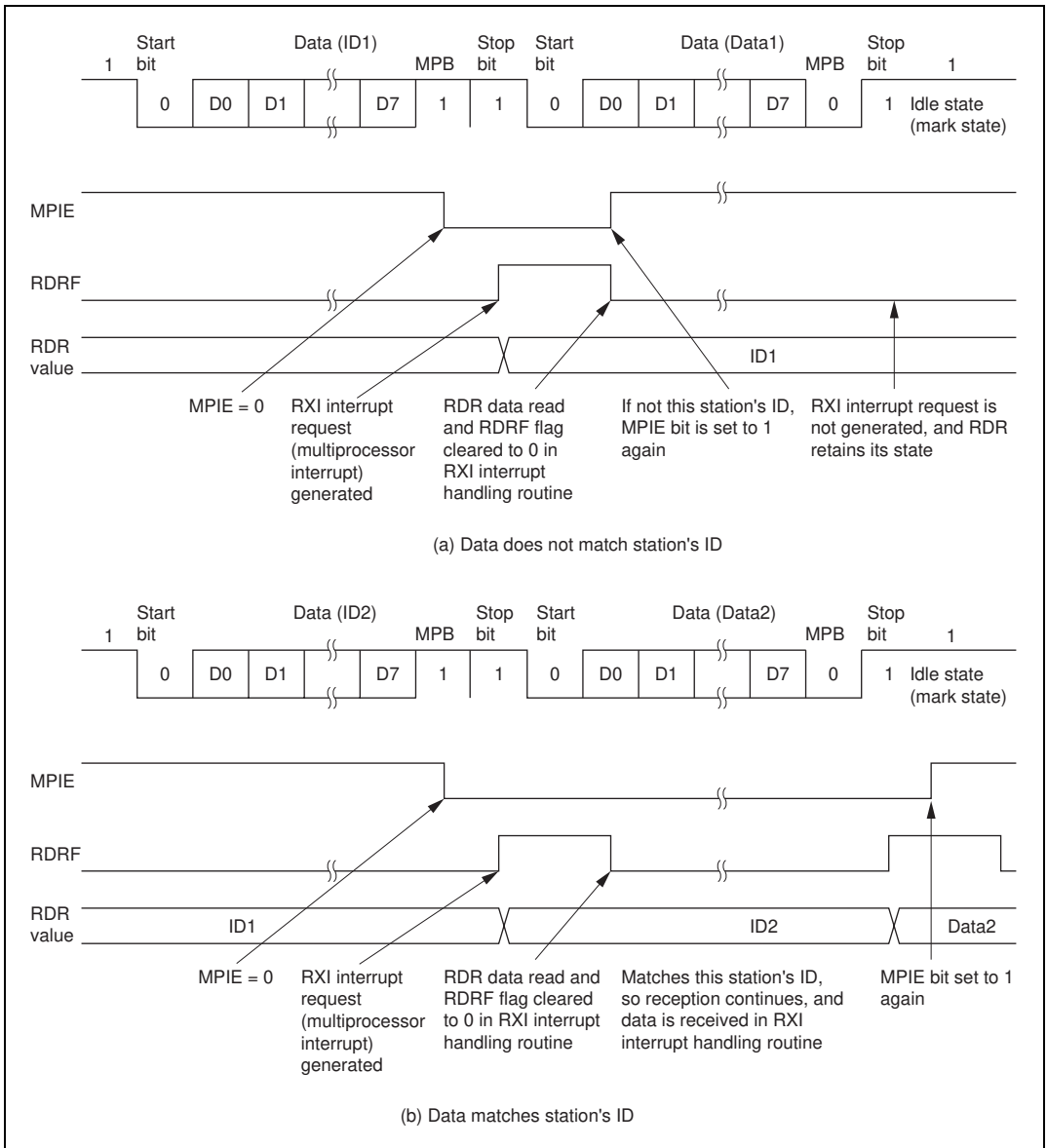

Figure 12.12 Sample Multiprocessor Serial Reception Flowchart (cont)

Figure 12.13 shows an example of SCI operation for multiprocessor format reception.



**Figure 12.13 Example of SCI Receive Operation
(Example with 8-Bit Data, Multiprocessor Bit, One Stop Bit)**

12.3.4 Operation in Synchronous Mode

In synchronous mode, data is transmitted or received in synchronization with clock pulses, making it suitable for high-speed serial communication.

Inside the SCI, the transmitter and receiver are independent units, enabling full-duplex communication by use of a common clock. Both the transmitter and the receiver also have a double-buffered structure, so that data can be read or written during transmission or reception, enabling continuous data transfer.

Figure 12.14 shows the general format for synchronous serial communication.

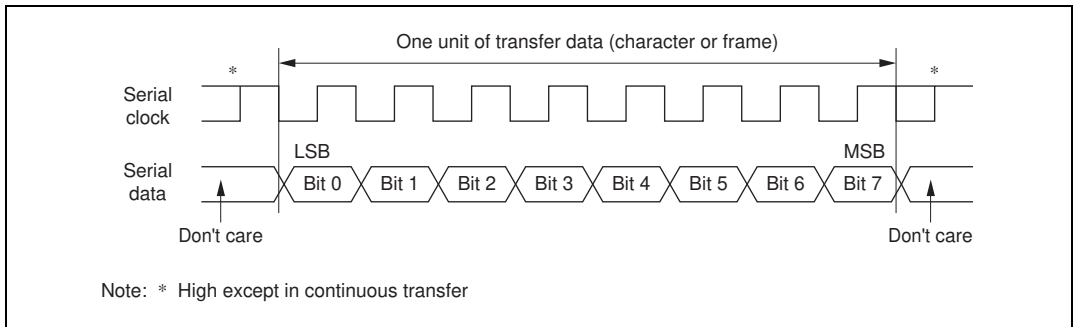

Figure 12.14 Data Format in Synchronous Communication

In synchronous serial communication, data on the communication line is output from one falling edge of the serial clock to the next. Data confirmation is guaranteed at the rising edge of the serial clock.

In synchronous serial communication, one character consists of data output starting with the LSB and ending with the MSB. After the MSB is output, the communication line holds the MSB state.

In synchronous mode, the SCI receives data in synchronization with the rising edge of the serial clock.

Data Transfer Format

A fixed 8-bit data format is used.

No parity or multiprocessor bits are added.

Clock

Either an internal clock generated by the built-in baud rate generator or an external serial clock input at the SCK pin can be selected, according to the setting of the $\overline{C/A}$ bit in SMR and the CKE1 and CKE0 bits in SCR. For details of SCI clock source selection, see table 12.9.

When the SCI is operated on an internal clock, the serial clock is output from the SCK pin.

Eight serial clock pulses are output in the transfer of one character, and when no transfer is performed the clock is fixed high. When only receive operations are performed, however, the serial clock is output until an overrun error occurs or the RE bit is cleared to 0. To perform receive operations in units of one character, an external clock should be selected as the clock source.

Data Transfer Operations

SCI initialization (synchronous mode): Before transmitting or receiving data, first clear the TE and RE bits in SCR to 0, then initialize the SCI as described below.

When the operating mode, transfer format, etc., is changed, the TE and RE bits must be cleared to 0 before making the change using the following procedure. When the TE bit is cleared to 0, the TDRE flag is set to 1 and TSR is initialized. Note that clearing the RE bit to 0 does not change the contents of the RDRF, PER, FER, and ORER flags, or the contents of RDR.

Figure 12.15 shows a sample SCI initialization flowchart.

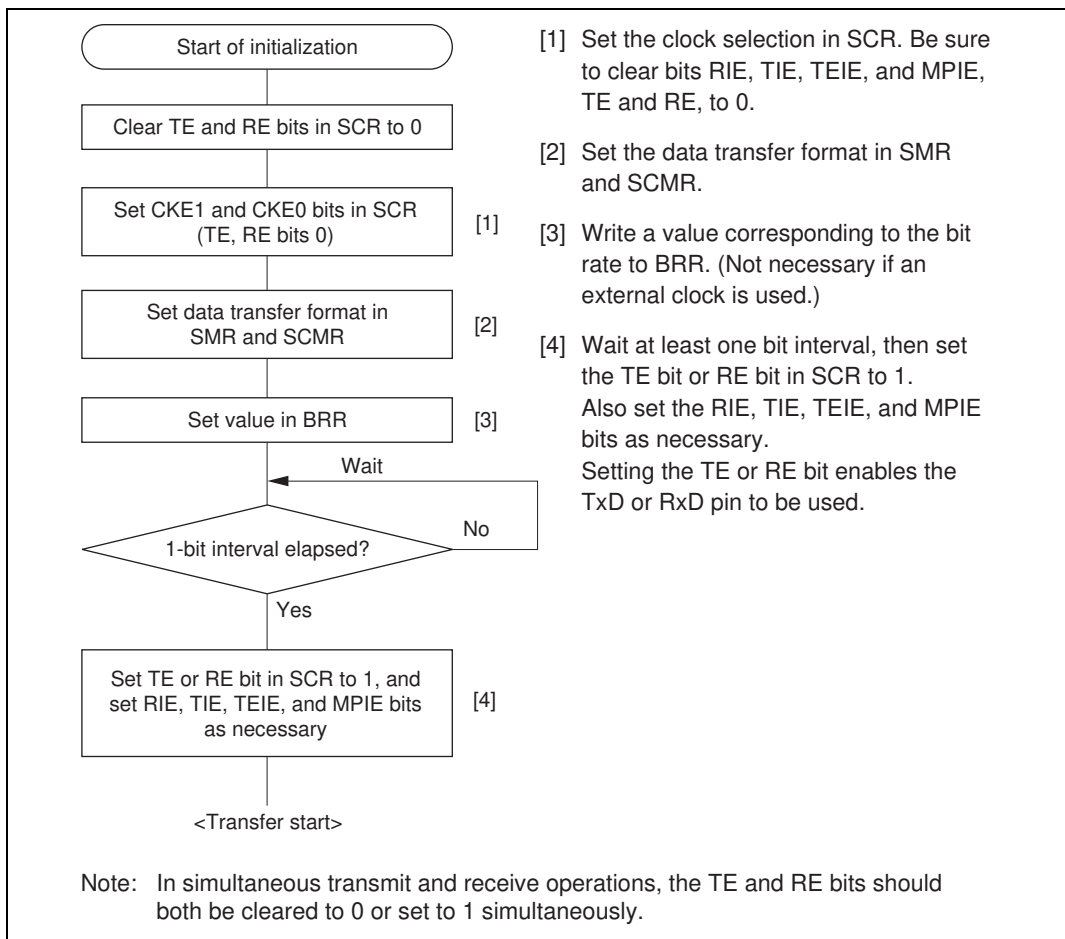

Figure 12.15 Sample SCI Initialization Flowchart

Serial data transmission (synchronous mode): Figure 12.16 shows a sample flowchart for serial transmission.

The following procedure should be used for serial data transmission.

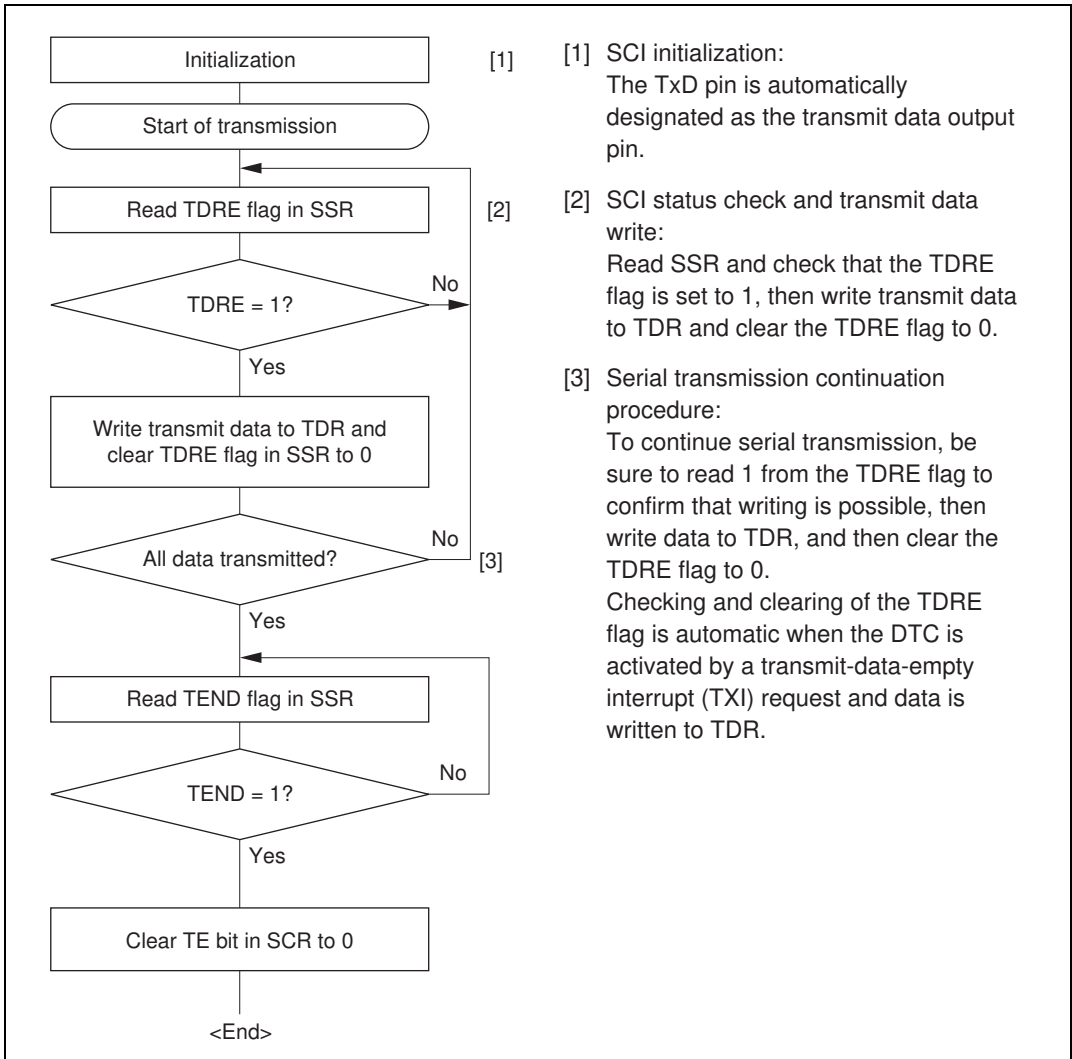

Figure 12.16 Sample Serial Transmission Flowchart

In serial transmission, the SCI operates as described below.

[1] The SCI monitors the TDRE flag in SSR, and if it is 0, recognizes that data has been written to TDR, and transfers the data from TDR to TSR.

[2] After transferring data from TDR to TSR, the SCI sets the TDRE flag to 1 and starts transmission. If the TIE bit is set to 1 at this time, a transmit-data-empty interrupt (TXI) is generated.

When clock output mode has been set, the SCI outputs 8 serial clock pulses. When use of an external clock has been specified, data is output synchronized with the input clock.

The serial transmit data is sent from the TxD pin starting with the LSB (bit 0) and ending with the MSB (bit 7).

[3] The SCI checks the TDRE flag at the timing for sending the MSB (bit 7).

If the TDRE flag is cleared to 0, data is transferred from TDR to TSR, and serial transmission of the next frame is started.

If the TDRE flag is set to 1, the TEND flag in SSR is set to 1, the MSB (bit 7) is sent, and the TxD pin maintains its state.

If the TEIE bit in SCR is set to 1 at this time, a TEI interrupt request is generated.

[4] After completion of serial transmission, the SCK pin is fixed.

Figure 12.17 shows an example of SCI operation in transmission.

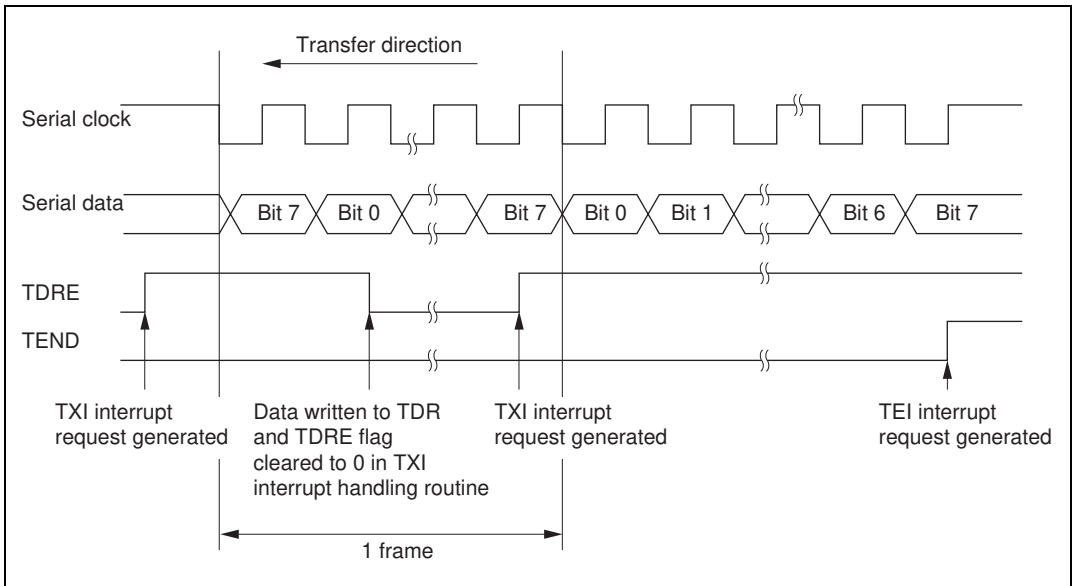

Figure 12.17 Example of SCI Transmit Operation

Serial data reception (synchronous mode): Figure 12.18 shows a sample flowchart for serial reception.

The following procedure should be used for serial data reception.

When changing the operating mode from asynchronous to synchronous, be sure to check that the ORER, PER, and FER flags are all cleared to 0.

The RDRF flag will not be set if the FER or PER flag is set to 1, and neither transmit nor receive operations will be possible.

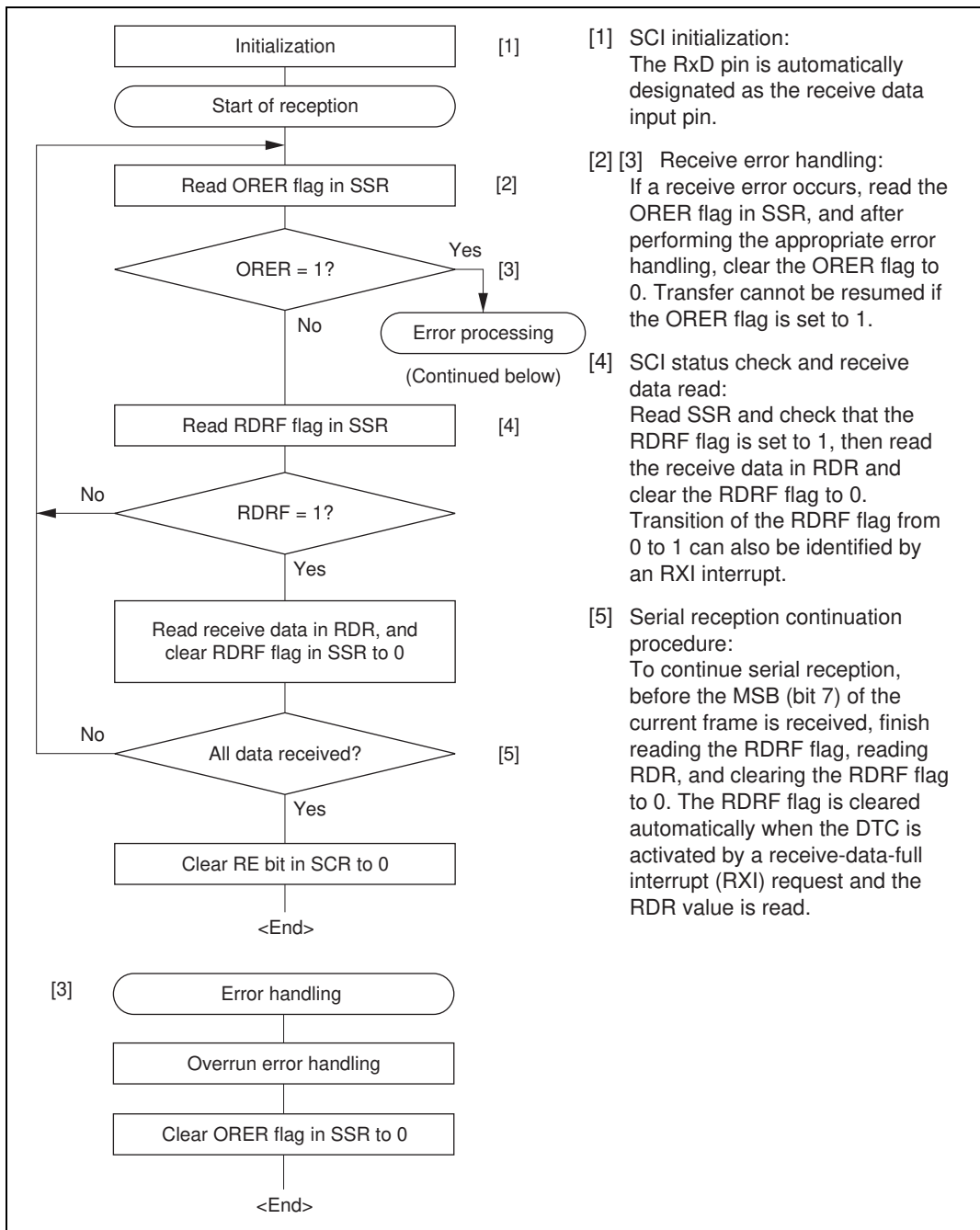

Figure 12.18 Sample Serial Reception Flowchart

In serial reception, the SCI operates as described below.

[1] The SCI performs internal initialization in synchronization with serial clock input or output.

[2] The received data is stored in RSR in LSB-to-MSB order.

After reception, the SCI checks whether the RDRF flag is 0 and the receive data can be transferred from RSR to RDR.

If this check is passed, the RDRF flag is set to 1, and the receive data is stored in RDR. If a receive error is detected in the error check, the operation is as shown in table 12.11.

Neither transmit nor receive operations can be performed subsequently when a receive error has been found in the error check.

[3] If the RIE bit in SCR is set to 1 when the RDRF flag changes to 1, a receive-data-full interrupt (RXI) request is generated.

Also, if the RIE bit in SCR is set to 1 when the ORER flag changes to 1, a receive-error interrupt (ERI) request is generated.

Figure 12.19 shows an example of SCI operation in reception.

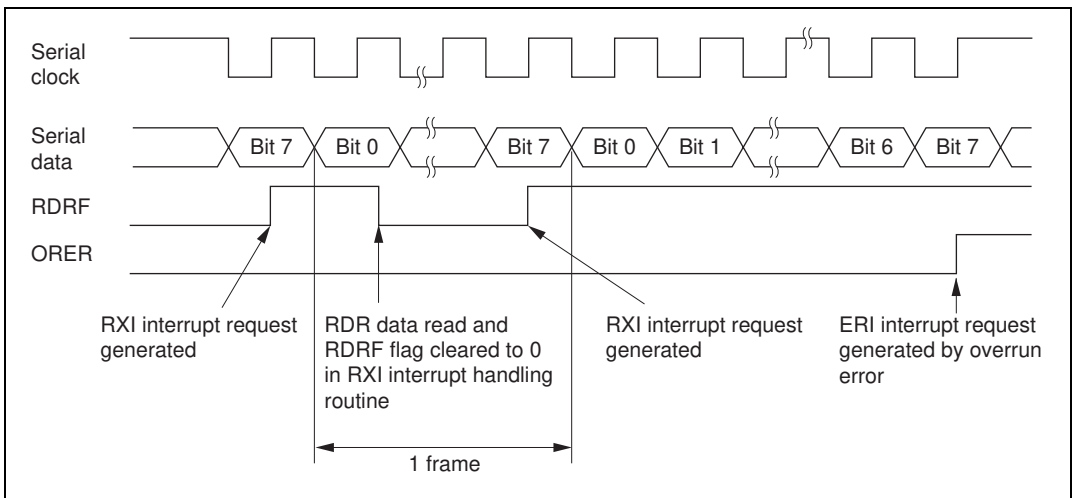
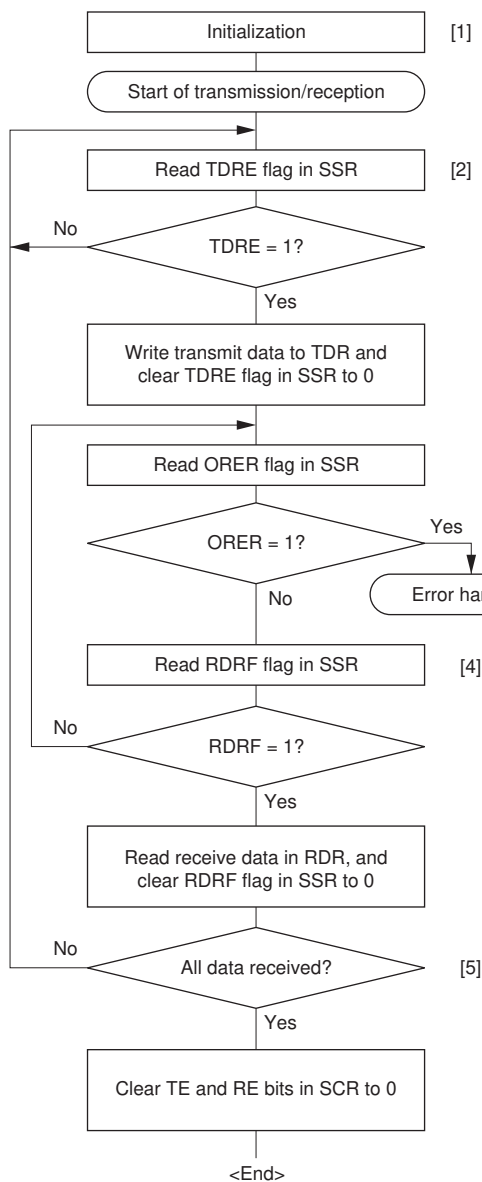

Figure 12.19 Example of SCI Receive Operation

Simultaneous serial data transmission and reception (synchronous mode): Figure 12.20 shows a sample flowchart for simultaneous serial transmit and receive operations.

The following procedure should be used for simultaneous serial data transmit and receive operations.



- [1] SCI initialization:
The TxD pin is designated as the transmit data output pin, and the RxD pin is designated as the receive data input pin, enabling simultaneous transmit and receive operations.
- [2] SCI status check and transmit data write:
Read SSR and check that the TDRE flag is set to 1, then write transmit data to TDR and clear the TDRE flag to 0.
Transition of the TDRE flag from 0 to 1 can also be identified by a TXI interrupt.
- [3] Receive error handling:
If a receive error occurs, read the ORER flag in SSR, and after performing the appropriate error handling, clear the ORER flag to 0. Transmission/reception cannot be resumed if the ORER flag is set to 1.
- [4] SCI status check and receive data read:
Read SSR and check that the RDRF flag is set to 1, then read the receive data in RDR and clear the RDRF flag to 0. Transition of the RDRF flag from 0 to 1 can also be identified by an RXI interrupt.
- [5] Serial transmission/reception continuation procedure:
To continue serial transmission/reception, before the MSB (bit 7) of the current frame is received, finish reading the RDRF flag, reading RDR, and clearing the RDRF flag to 0. Also, before the MSB (bit 7) of the current frame is transmitted, read 1 from the TDRE flag to confirm that writing is possible. Then write data to TDR and clear the TDRE flag to 0.
Checking and clearing of the TDRE flag is automatic when the DTC is activated by a transmit-data-empty interrupt (TXI) request and data is written to TDR. Also, the RDRF flag is cleared automatically when the DTC is activated by a receive-data-full interrupt (RXI) request and the RDR value is read.

Note: When switching from transmit or receive operation to simultaneous transmit and receive operations, first clear the TE and RE bits to 0, then set both these bits to 1 simultaneously.

Figure 12.20 Sample Flowchart of Simultaneous Serial Transmit and Receive Operations

12.4 SCI Interrupts

The SCI has four interrupt sources: the transmit-end interrupt (TEI) request, receive-error interrupt (ERI) request, receive-data-full interrupt (RXI) request, and transmit-data-empty interrupt (TXI) request. Table 12.12 shows the interrupt sources and their relative priorities. Individual interrupt sources can be enabled or disabled with the TIE, RIE, and TEIE bits in the SCR. Each kind of interrupt request is sent to the interrupt controller independently.

When the TDRE flag in SSR is set to 1, a TXI interrupt request is generated. When the TEND flag in SSR is set to 1, a TEI interrupt request is generated. A TXI interrupt can activate the DTC to perform data transfer. The TDRE flag is cleared to 0 automatically when data transfer is performed by the DTC. The DTC cannot be activated by a TEI interrupt request.

When the RDRF flag in SSR is set to 1, an RXI interrupt request is generated. When the ORER, PER, or FER flag in SSR is set to 1, an ERI interrupt request is generated. An RXI interrupt can activate the DTC to perform data transfer. The RDRF flag is cleared to 0 automatically when data transfer is performed by the DTC. The DTC cannot be activated by an ERI interrupt request.

Table 12.12 SCI Interrupt Sources

Channel	Interrupt Source	Description	DTC Activation	Priority*
0	ERI	Interrupt due to receive error (ORER, FER, or PER)	Not possible	High ↑ Low
	RXI	Interrupt due to receive data full state (RDRF)	Possible	
	TXI	Interrupt due to transmit data empty state (TDRE)	Possible	
	TEI	Interrupt due to transmission end (TEND)	Not possible	
1	ERI	Interrupt due to receive error (ORER, FER, or PER)	Not possible	
	RXI	Interrupt due to receive data full state (RDRF)	Possible	
	TXI	Interrupt due to transmit data empty state (TDRE)	Possible	
	TEI	Interrupt due to transmission end (TEND)	Not possible	

Note: * This table shows the initial state immediate after a reset. Relative priorities among channels can be changed by the interrupt controller.

A TEI interrupt is requested when the TEND flag is set to 1 while the TEIE bit is set to 1. The TEND flag is cleared at the same time as the TDRE flag. Consequently, if a TEI interrupt and a TXI interrupt are requested simultaneously, the TXI interrupt may be accepted first, with the result that the TDRE and TEND flags are cleared. Note that the TEI interrupt will not be accepted in this case.

12.5 Usage Notes

The following points should be noted when using the SCI.

Relation between Writes to TDR and the TDRE Flag: The TDRE flag in SSR is a status flag that indicates that transmit data has been transferred from TDR to TSR. When the SCI transfers data from TDR to TSR, the TDRE flag is set to 1.

Data can be written to TDR regardless of the state of the TDRE flag. However, if new data is written to TDR when the TDRE flag is cleared to 0, the data stored in TDR will be lost since it has not yet been transferred to TSR. It is therefore essential to check that the TDRE flag is set to 1 before writing transmit data to TDR.

Operation when Multiple Receive Errors Occur Simultaneously: If a number of receive errors occur at the same time, the state of the status flags in SSR is as shown in table 12.13. If there is an overrun error, data is not transferred from RSR to RDR, and the receive data is lost.

Table 12.13 State of SSR Status Flags and Transfer of Receive Data

SSR Status Flags				Receive Data Transfer from RSR to RDR	Receive Error Status
RDRF	ORER	FER	PER		
1	1	0	0	X	Overrun error
0	0	1	0	○	Framing error
0	0	0	1	○	Parity error
1	1	1	0	X	Overrun error + framing error
1	1	0	1	X	Overrun error + parity error
0	0	1	1	○	Framing error + parity error
1	1	1	1	X	Overrun error + framing error + parity error

Notes: ○ : Receive data is transferred from RSR to RDR.

X: Receive data is not transferred from RSR to RDR.

Break Detection and Processing (Asynchronous Mode Only): When framing error (FER) detection is performed, a break can be detected by reading the RxD pin value directly. In a break, the input from the RxD pin becomes all 0s, and so the FER flag is set, and the parity error flag (PER) may also be set.

Note that, since the SCI continues the receive operation after receiving a break, even if the FER flag is cleared to 0, it will be set to 1 again.

Sending a Break (Asynchronous Mode Only): The TxD pin has a dual function as an I/O port whose direction (input or output) is determined by DR and DDR. This can be used to send a break.

Between serial transmission initialization and setting of the TE bit to 1, the mark state is replaced by the value of DR (the pin does not function as the TxD pin until the TE bit is set to 1). Therefore, DDR and DR for the port corresponding to the TxD pin should first be set to 1.

To send a break during serial transmission, first clear DR to 0, then clear the TE bit to 0.

When the TE bit is cleared to 0, the transmitter is initialized regardless of the current transmission state, the TxD pin becomes an I/O port, and 0 is output from the TxD pin.

Receive Error Flags and Transmit Operations (Synchronous Mode Only): Transmission cannot be started when a receive error flag (ORER, PER, or FER) is set to 1, even if the TDRE flag is cleared to 0. Be sure to clear the receive error flags to 0 before starting transmission.

Note also that receive error flags cannot be cleared to 0 even if the RE bit is cleared to 0.

Receive Data Sampling Timing and Receive Margin in Asynchronous Mode: In asynchronous mode, the SCI operates on a base clock with a frequency of 16 times the transfer rate.

In reception, the SCI samples the falling edge of the start bit using the base clock, and performs internal synchronization. Receive data is latched internally at the rising edge of the 8th pulse of the base clock. This is illustrated in figure 12.21.

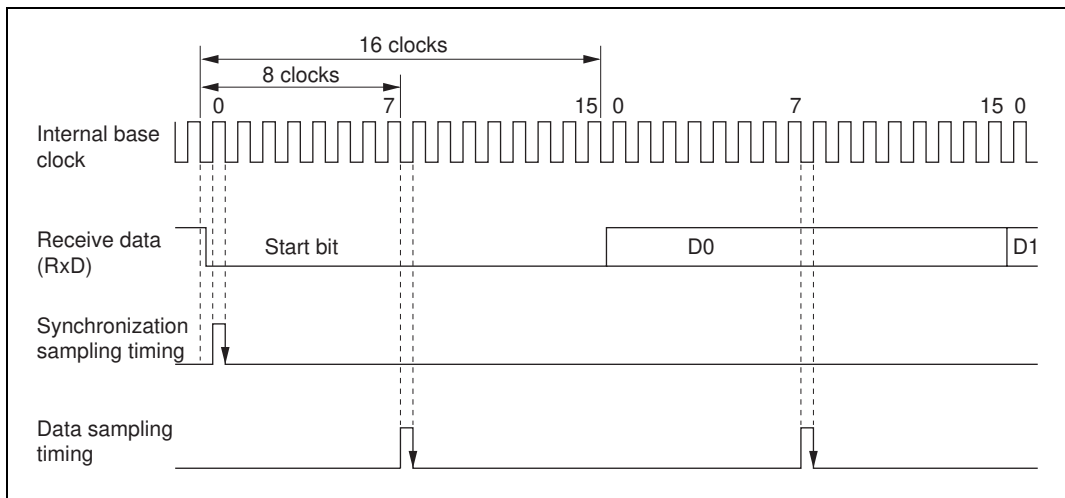

Figure 12.21 Receive Data Sampling Timing in Asynchronous Mode

Thus the receive margin in asynchronous mode is given by formula (1) below.

$$M = \left| \left(0.5 - \frac{1}{2N} \right) - (L - 0.5) F - \frac{|D - 0.5|}{N} (1 + F) \right| \times 100\% \quad \dots \text{Formula (1)}$$

Where M: Receive margin (%)
 N: Ratio of bit rate to clock ($N = 16$)
 D: Clock duty ($D = 0$ to 1.0)
 L: Frame length ($L = 9$ to 12)
 F: Absolute value of clock rate deviation

Assuming values of $F = 0$ and $D = 0.5$ in formula (1), a receive margin of 46.875% is given by formula (2) below.

When $D = 0.5$ and $F = 0$,

$$\begin{aligned} M &= \left(0.5 - \frac{1}{2 \times 16} \right) \times 100\% \\ &= 46.875\% \quad \dots \text{Formula (2)} \end{aligned}$$

However, this is a theoretical value, and a margin of 20% to 30% should be allowed in system design.

Restrictions on Use of DTC

- When an external clock source is used as the serial clock, the transmit clock should not be input until at least 5 ϕ clock cycles after TDR is updated by the DTC. Misoperation may occur if the transmit clock is input within 4 ϕ clocks after TDR is updated. (Figure 12.22)
- When RDR is read by the DTC, be sure to set the activation source to the relevant SCI receive-data-full interrupt (RXI).

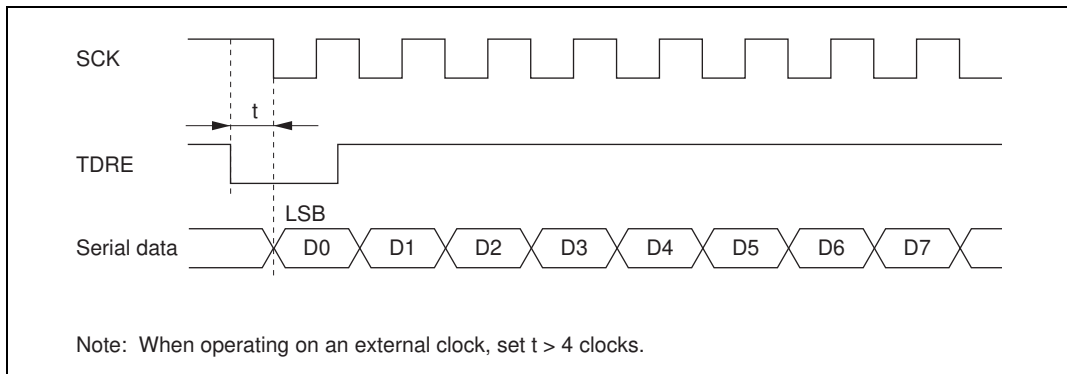

Figure 12.22 Example of Synchronous Transmission Using DTC

Operation in Case of Mode Transition

• Transmission

Operation should be stopped (by clearing TE, TIE, and TEIE to 0) before making a module stop mode or software standby mode transition. TSR, TDR, and SSR are reset. The output pin states in module stop mode or software standby mode depend on the port settings, and becomes high-level output after the relevant mode is cleared. If a transition is made during transmission, the data being transmitted will be undefined. When transmitting without changing the transmit mode after the relevant mode is cleared, transmission can be started by setting TE to 1 again, and performing the following sequence: SSR read → TDR write → TDRE clearance. To transmit with a different transmit mode after clearing the relevant mode, the procedure must be started again from initialization. Figure 12.23 shows a sample flowchart for mode transition during transmission. Port pin states are shown in figures 12.24 and 12.25. Operation should also be stopped (by clearing TE, TIE, and TEIE to 0) before making a transition from transmission by DTC transfer to module stop mode or software standby mode transition. To perform transmission with the DTC after the relevant mode is cleared, setting TE and TIE to 1 will set the TXI flag and start DTC transmission.

- Reception

Receive operation should be stopped (by clearing RE to 0) before making a module stop mode or software standby mode transition. RSR, RDR, and SSR are reset. If a transition is made without stopping operation, the data being received will be invalid.

To continue receiving without changing the reception mode after the relevant mode is cleared, set RE to 1 before starting reception. To receive with a different receive mode, the procedure must be started again from initialization.

Figure 12.26 shows a sample flowchart for mode transition during reception.

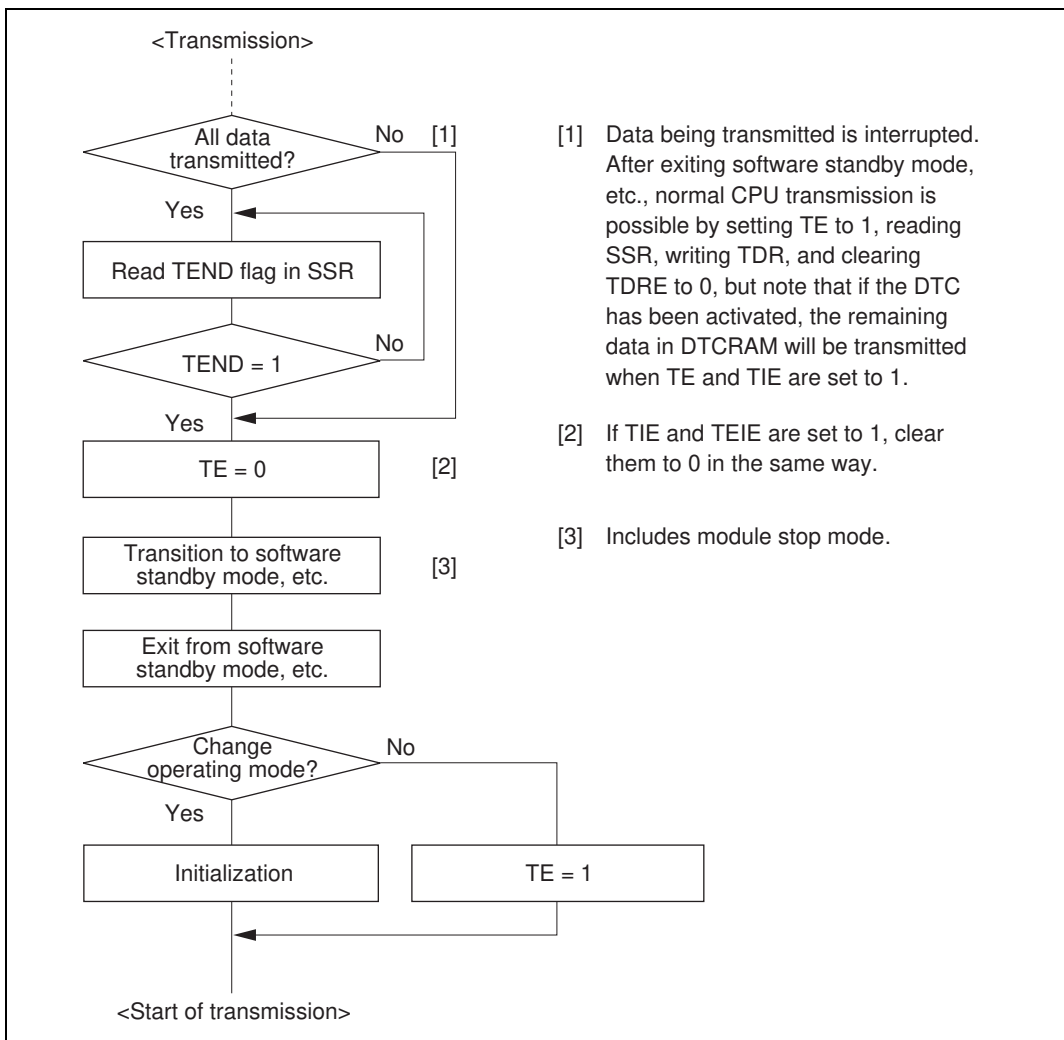

Figure 12.23 Sample Flowchart for Mode Transition during Transmission

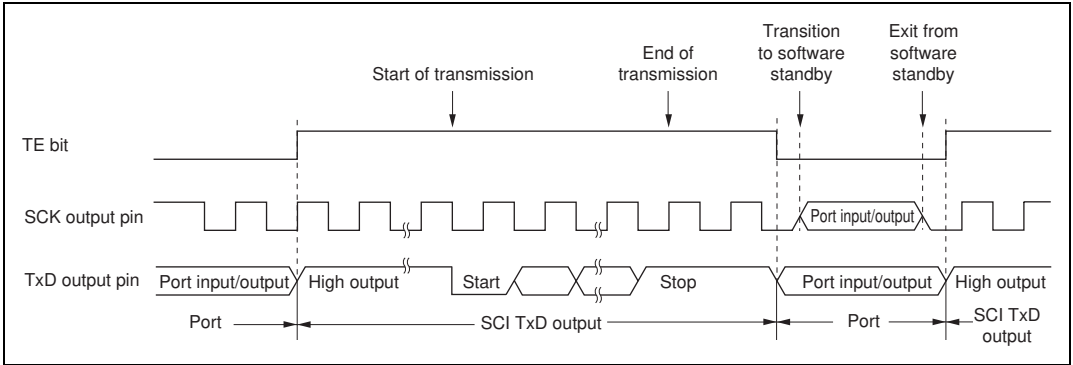

Figure 12.24 Asynchronous Transmission Using Internal Clock

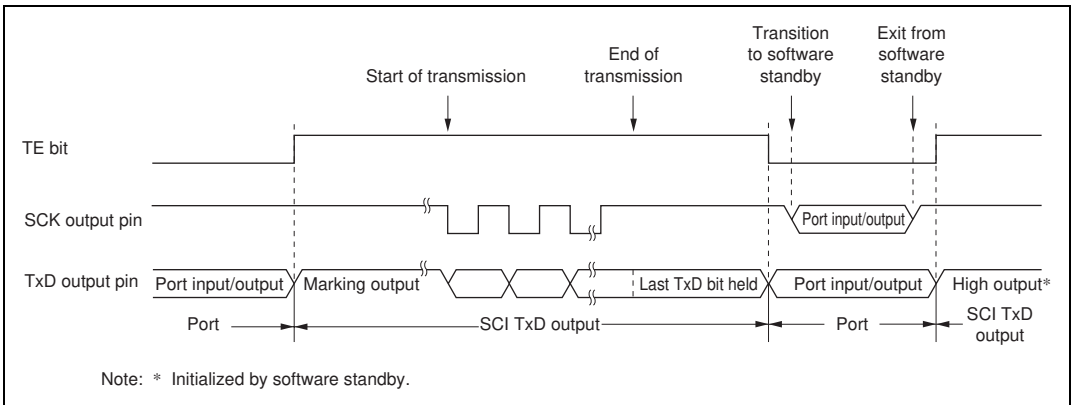

Figure 12.25 Synchronous Transmission Using Internal Clock

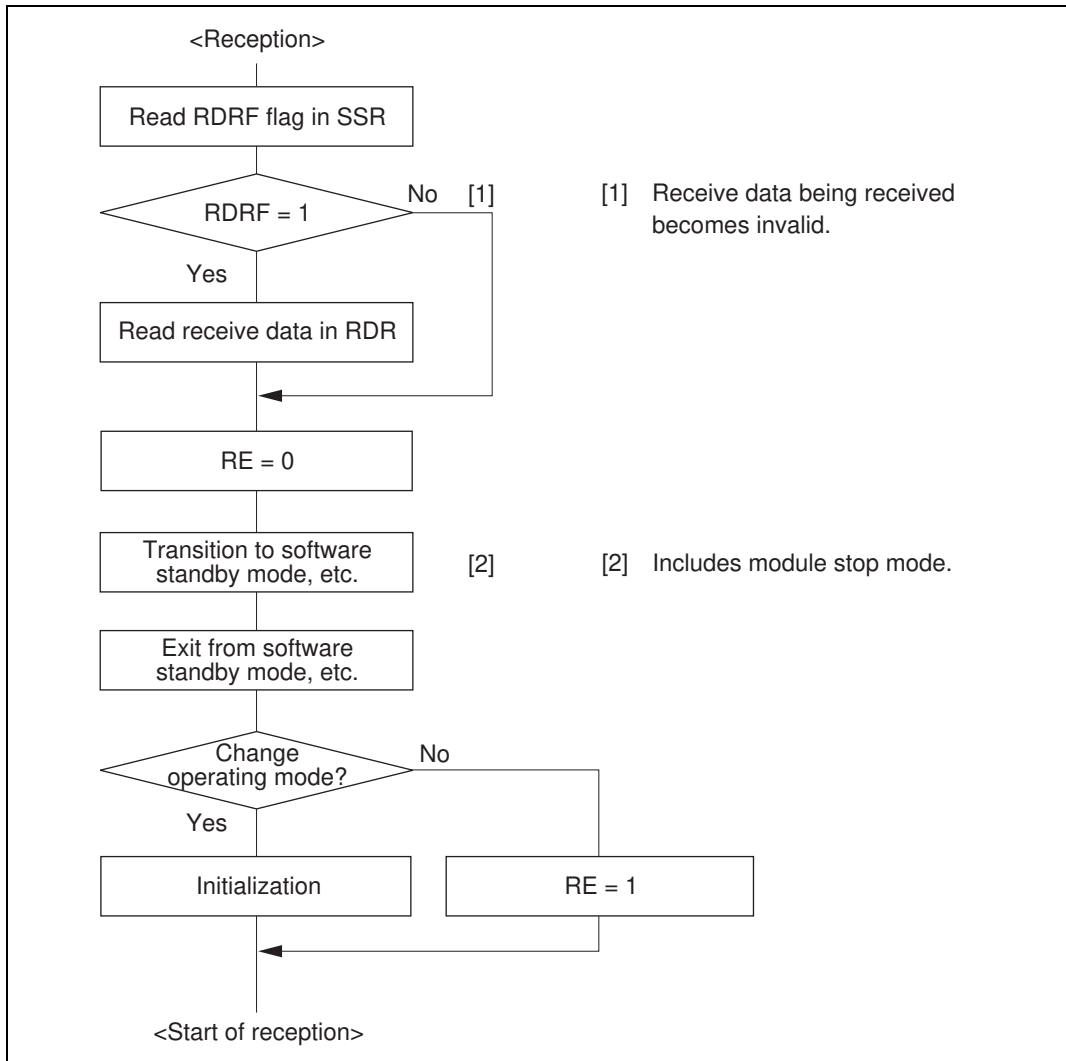

Figure 12.26 Sample Flowchart for Mode Transition during Reception

Section 13 Smart Card Interface

13.1 Overview

The SCI supports an IC card (smart card) interface conforming to ISO/IEC 7816-3 (identification card) as a serial communication interface extension function.

Switching between the normal serial communication interface and the smart card interface is carried out by means of a register setting.

13.1.1 Features

Features of the smart card interface supported by the chip is as follows.

- Asynchronous mode
 - Data length: 8 bits
 - Parity bit generation and checking
 - Transmission of error signal (parity error) in receive mode
 - Error signal detection and automatic data retransmission in transmit mode
 - Direct convention and inverse convention both supported
- Built-in baud rate generator allows any bit rate to be selected
- Three interrupt sources
 - Three interrupt sources (transmit-data-empty, receive-data-full, and transmit/receive-error) that can issue requests independently
 - The transmit-data-empty and receive-data-full interrupts can activate the data transfer controller (DTC) to execute data transfer

13.1.2 Block Diagram

Figure 13.1 shows a block diagram of the smart card interface.

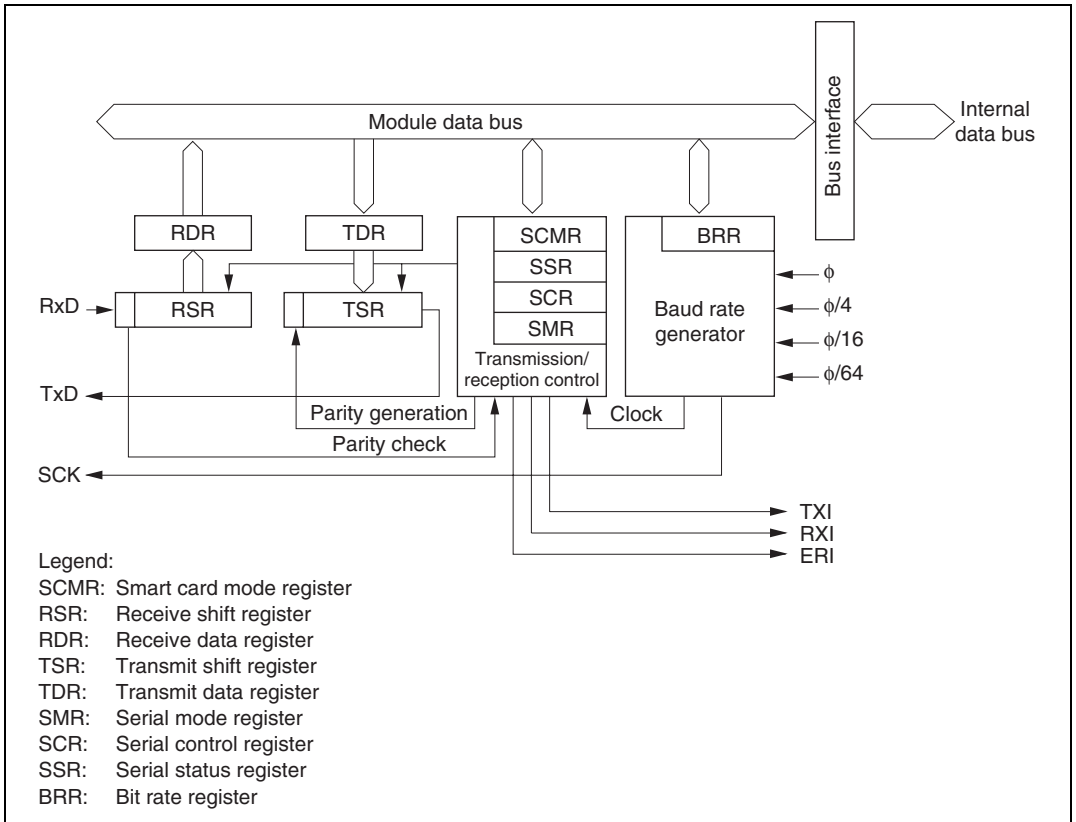

Figure 13.1 Block Diagram of Smart Card Interface

13.1.3 Pin Configuration

Table 13.1 shows the smart card interface pin configuration.

Table 13.1 Smart Card Interface Pins

Channel	Pin Name	Symbol	I/O	Function
0	Serial clock pin 0	SCK0	I/O	SCI0 clock input/output
	Receive data pin 0	RxD0	Input	SCI0 receive data input
	Transmit data pin 0	TxD0	Output	SCI0 transmit data output
1	Serial clock pin 1	SCK1	I/O	SCI1 clock input/output
	Receive data pin 1	RxD1	Input	SCI1 receive data input
	Transmit data pin 1	TxD1	Output	SCI1 transmit data output

13.1.4 Register Configuration

Table 13.2 shows the registers used by the smart card interface. Details of SMR, BRR, SCR, TDR, RDR, and MSTPCR are the same as for the normal SCI function: see the register descriptions in section 12, Serial Communication Interface (SCI).

Table 13.2 Smart Card Interface Registers

Channel	Name	Abbreviation	R/W	Initial Value	Address ^{*2}
0	Serial mode register 0	SMR0	R/W	H'00	H'FF78
	Bit rate register 0	BRR0	R/W	H'FF	H'FF79
	Serial control register 0	SCR0	R/W	H'00	H'FF7A
	Transmit data register 0	TDR0	R/W	H'FF	H'FF7B
	Serial status register 0	SSR0	R/(W) ^{*1}	H'84	H'FF7C
	Receive data register 0	RDR0	R	H'00	H'FF7D
	Smart card mode register 0	SCMR0	R/W	H'F2	H'FF7E
1	Serial mode register 1	SMR1	R/W	H'00	H'FF80
	Bit rate register 1	BRR1	R/W	H'FF	H'FF81
	Serial control register 1	SCR1	R/W	H'00	H'FF82
	Transmit data register 1	TDR1	R/W	H'FF	H'FF83
	Serial status register 1	SSR1	R/(W) ^{*1}	H'84	H'FF84
	Receive data register 1	RDR1	R	H'00	H'FF85
	Smart card mode register 1	SCMR1	R/W	H'F2	H'FF86
All	Module stop control register	MSTPCR	R/W	H'3FFF	H'FF3C

Notes: 1. Can only be written with 0 for flag clearing.

2. Lower 16 bits of the address.

13.2 Register Descriptions

Registers added with the smart card interface and bits for which the function changes are described here.

13.2.1 Smart Card Mode Register (SCMR)

Bit	:	7	6	5	4	3	2	1	0
		—	—	—	—	SDIR	SINV	—	SMIF
Initial value	:	1	1	1	1	0	0	1	0
R/W	:	—	—	—	—	R/W	R/W	—	R/W

SCMR is an 8-bit readable/writable register that selects the smart card interface function.

SCMR is initialized to HF2 by a reset and in hardware standby mode. In software standby mode and module stop mode it retains its previous state.

Bits 7 to 4—Reserved: These bits cannot be modified and are always read as 1.

Bit 3—Smart Card Data Transfer Direction (SDIR): Selects the serial/parallel conversion format.

Bit 3

SDIR	Description
0	TDR contents are transmitted LSB-first Receive data is stored in RDR LSB-first (Initial value)
1	TDR contents are transmitted MSB-first Receive data is stored in RDR MSB-first

Bit 2—Smart Card Data Invert (SINV): Specifies inversion of the data logic level. This function is used together with the SDIR bit for communication with an inverse convention card. The SINV bit does not affect the logic level of the parity bit. For parity-related setting procedures, see section 13.3.4, Register Settings.

Bit 2

SINV	Description	
0	TDR contents are transmitted as they are Receive data is stored as it is in RDR	(Initial value)
1	TDR contents are inverted before being transmitted Receive data is stored in inverted form in RDR	

Bit 1—Reserved: Read-only bit, always read as 1.

Bit 0—Smart Card Interface Mode Select (SMIF): Enables or disables the smart card interface function.

Bit 0

SMIF	Description	
0	Smart card interface function is disabled	(Initial value)
1	Smart card interface function is enabled	

13.2.2 Serial Status Register (SSR)

Bit	7	6	5	4	3	2	1	0
	TDRE	RDRF	ORER	ERS	PER	TEND	MPB	MPBT
Initial value :	1	0	0	0	0	1	0	0
R/W :	R/(W)*	R/(W)*	R/(W)*	R/(W)*	R/(W)*	R	R	R/W

Note: * Only 0 can be written to bits 7 to 3, to clear these flags.

Bit 4 of SSR has a different function in smart card interface mode. Coupled with this, the setting conditions for bit 2, TEND, are also different.

Bits 7 to 5—Operate in the same way as for the normal SCI. For details, see section 12.2.7, Serial Status Register (SSR).

Bit 4—Error Signal Status (ERS): In smart card interface mode, bit 4 indicates the status of the error signal sent back from the receiving end in transmission. Framing errors are not detected in smart card interface mode.

Bit 4

ERS	Description
0	Indicates data received normally with no error signal [Clearing conditions] (Initial value) <ul style="list-style-type: none"> • Upon reset, and in standby mode or module stop mode • When 0 is written to ERS after reading ERS = 1
1	Indicates an error signal was sent showing detection of a parity error at the receiving side [Setting condition] When the low level of the error signal is sampled

Note: Clearing the TE bit in SCR to 0 does not affect the ERS flag, which retains its previous state.

Bits 3 to 0—Operate in the same way as for the normal SCI. For details, see section 12.2.7, Serial Status Register (SSR).

However, the setting conditions for the TEND bit, are as shown below.

Bit 2

TEND	Description
0	Indicates transfer in progress [Clearing conditions] <ul style="list-style-type: none"> • When 0 is written to TDRE after reading TDRE = 1 • When the DTC is activated by a TXI interrupt and writes data to TDR
1	Indicates transfer complete [Setting conditions] (Initial value) <ul style="list-style-type: none"> • Upon reset, and in standby mode or module stop mode • When the TE bit in SCR is 0 and the ERS bit is also 0 • When TDRE = 1 and ERS = 0 (normal transmission) 2.5 etu after transmission of a 1-byte serial character when GM = 0 and BLK = 0 • When TDRE = 1 and ERS = 0 (normal transmission) 1.5 etu after transmission of a 1-byte serial character when GM = 0 and BLK = 1 • When TDRE = 1 and ERS = 0 (normal transmission) 1.0 etu after transmission of a 1-byte serial character when GM = 1 and BLK = 0 • When TDRE = 1 and ERS = 0 (normal transmission) 1.0 etu after transmission of a 1-byte serial character when GM = 1 and BLK = 1

Note: etu: Elementary time unit (time for transfer of 1 bit)

13.2.3 Serial Mode Register (SMR)

Bit	:	7	6	5	4	3	2	1	0
		GM	BLK	PE*	O/E	BCP1	BCP0	CKS1	CKS0
Initial value	:	0	0	0	0	0	0	0	0
R/W	:	R/W	R/W	R/W	R/W	R/W	R/W	R/W	R/W

Note: * When the smart card interface is used, set a value of 1 in bit 5.

The function of bits 7, 6, 3, and 2 of SMR changes in smart card interface mode.

Bit 7—GSM Mode (GM): Sets the smart card interface function to GSM mode.

This bit is cleared to 0 when the normal smart card interface is used. In GSM mode, this bit is set to 1, the timing of setting of the TEND flag that indicates transmission completion is advanced, and clock output control mode addition is performed. The contents of the clock output control mode addition are specified by bits 1 and 0 of the serial control register (SCR).

Bit 7

GM	Description
0	Normal smart card interface mode operation (Initial value) <ul style="list-style-type: none"> TEND flag generation 12.5 etu (11.5 etu in block transfer mode) after beginning of start bit Clock output on/off control only
1	GSM mode smart card interface mode operation <ul style="list-style-type: none"> TEND flag generation 11.0 etu after beginning of start bit High/low fixing control possible in addition to clock output on/off control (set by SCR)

Note: etu: Elementary time unit (time for transfer of 1 bit)

Bit 6—Block Transfer Mode (BLK): Selects block transfer mode.

Bit 6

BLK	Description
0	Normal smart card interface mode operation (Initial value) <ul style="list-style-type: none"> • Error signal transmission/detection and automatic data retransmission performed • TXI interrupt generated by TEND flag • TEND flag set 12.5 etu after start of transmission (11.0 etu in GSM mode)
1	Block transfer mode operation <ul style="list-style-type: none"> • Error signal transmission/detection and automatic data retransmission not performed • TXI interrupt generated by TDRE flag • TEND flag set 11.5 etu after start of transmission (11.0 etu in GSM mode)

Note: etu: Elementary time unit (time for transfer of 1 bit)

Bits 3 and 2—Base Clock Pulse 1 and 2 (BCP1, BCP0): These bits specify the number of base clock periods in a 1-bit transfer interval on the smart card interface.

Bit 3 BCP1	Bit 2 BCP0	Description
0	0	32 clock periods (Initial value)
	1	64 clock periods
1	0	372 clock periods
	1	256 clock periods

Bits 5, 4, 1, and 0—Operate in the same way as for the normal SCI. For details, see section 12.2.5, Serial Mode Register (SMR).

13.2.4 Serial Control Register (SCR)

Bit	:	7	6	5	4	3	2	1	0
		TIE	RIE	TE	RE	MPIE	TEIE	CKE1	CKE0
Initial value :		0	0	0	0	0	0	0	0
R/W	:	R/W	R/W	R/W	R/W	R/W	R/W	R/W	R/W

In smart card interface mode, the function of bits 1 and 0 of SCR changes when bit 7 of the serial mode register (SMR) is set to 1.

Bits 7 to 2—Operate in the same way as for the normal SCI. For details, see section 12.2.6, Serial Control Register (SCR).

Bits 1 and 0—**Clock Enable 1 and 0 (CKE1, CKE0)**: These bits are used to select the SCI clock source and enable or disable clock output from the SCK pin.

In smart card interface mode, in addition to the normal switching between clock output enabling and disabling, the clock output can be specified as being fixed high or low.

SCMR	SMR	SCR Setting		SCK Pin Function
SMIF	GM	CKE1	CKE0	
0		See the SCI specification		
1	0	0	0	Operates as port I/O pin
1	0	0	1	Outputs clock as SCK output pin
1	1	0	0	Operates as SCK output pin, with output fixed low
1	1	0	1	Outputs clock as SCK output pin
1	1	1	0	Operates as SCK output pin, with output fixed high
1	1	1	1	Outputs clock as SCK output pin

13.3 Operation

13.3.1 Overview

The main functions of the smart card interface are as follows.

- One frame consists of 8-bit data plus a parity bit.
- In transmission, a guard time of at least 2 etu (1 etu in block transfer mode) (elementary time unit: the time for transfer of 1 bit) is left between the end of the parity bit and the start of the next frame.
- If a parity error is detected during reception, a low error signal level is output for one etu period, 10.5 etu after the start bit. (This does not apply to block transfer mode.)
- If the error signal is sampled during transmission, the same data is transmitted automatically after the elapse of 2 etu or longer. (This does not apply to block transfer mode.)
- Only asynchronous communication is supported; there is no synchronous communication function.

13.3.2 Pin Connections

Figure 13.2 shows a schematic diagram of smart card interface related pin connections.

In communication with an IC card, since both transmission and reception are carried out on a single data communication line, the chip's TxD pin and RxD pin should both be connected to the line, as shown in the figure. The data communication line should be pulled up to the V_{CC} power supply with a resistor.

When the clock generated on the smart card interface is used by an IC card, the SCK pin output is input to the CLK pin of the IC card. No connection is needed if the IC card uses an internal clock.

Chip port output is used as the reset signal.

Other pins must normally be connected to the power supply or ground.

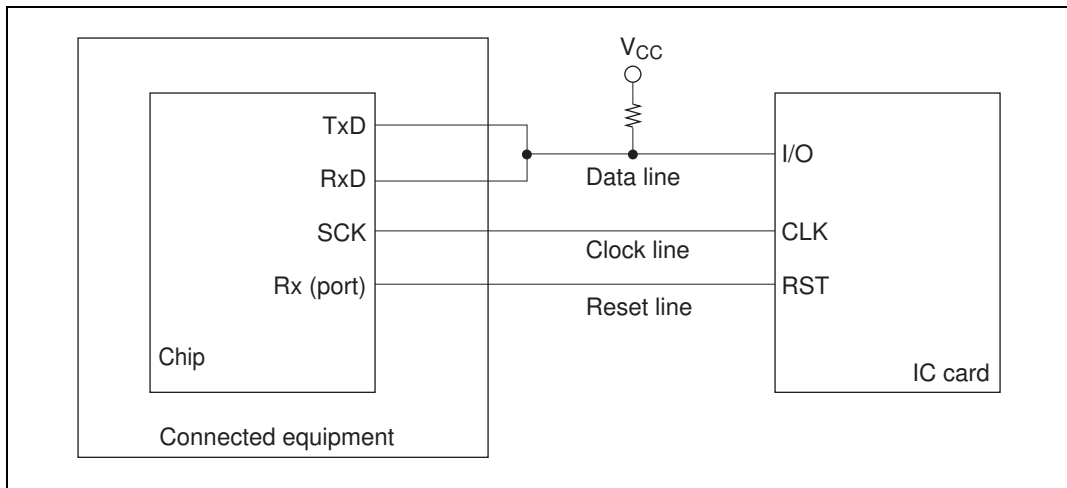

Figure 13.2 Schematic Diagram of Smart Card Interface Pin Connections

Note: If an IC card is not connected, and the TE and RE bits are both set to 1, closed transmission/reception is possible, enabling self-diagnosis to be carried out.

13.3.3 Data Format

Normal Transfer Mode: Figure 13.3 shows the smart card interface data format in the normal transfer mode. In reception in this mode, a parity check is carried out on each frame. If an error is detected an error signal is sent back to the transmitting end, and retransmission of the data is requested. If an error signal is sampled during transmission, the same data is retransmitted.

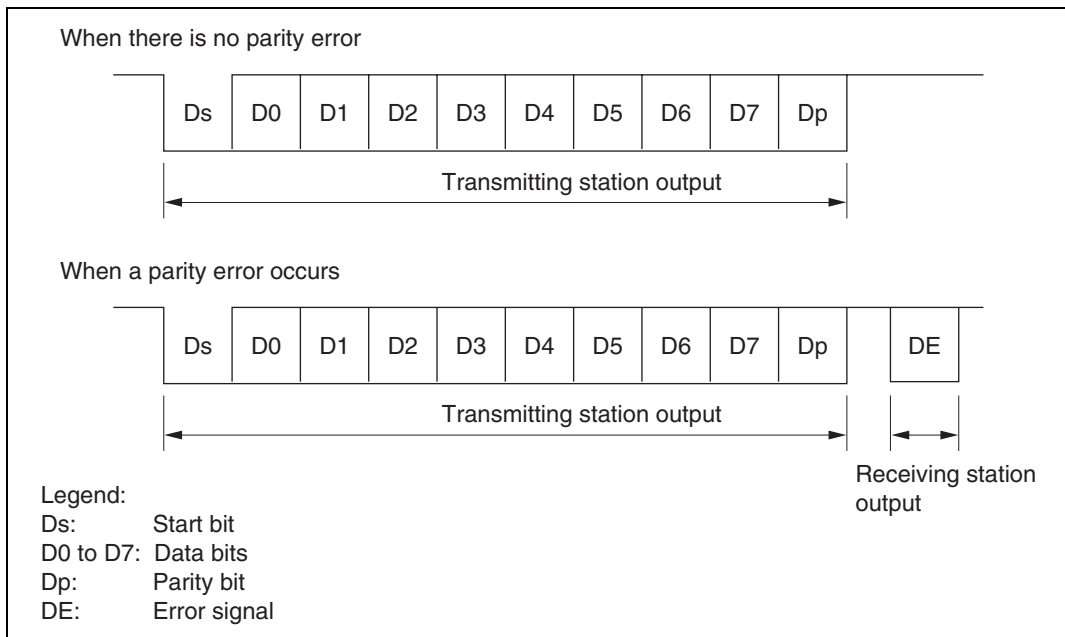

Figure 13.3 Smart Card Interface Data Format

The operation sequence is as follows.

- [1] When the data line is not in use it is in the high-impedance state, and is fixed high with a pull-up resistor.
- [2] The transmitting station starts transfer of one frame of data. The data frame starts with a start bit (Ds, low-level), followed by 8 data bits (D0 to D7) and a parity bit (Dp).
- [3] With the smart card interface, the data line then returns to the high-impedance state. The data line is pulled high with a pull-up resistor.
- [4] The receiving station carries out a parity check.
If there is no parity error and the data is received normally, the receiving station waits for reception of the next data.
If a parity error occurs, however, the receiving station outputs an error signal (DE, low-level) to request retransmission of the data. After outputting the error signal for the prescribed length of time, the receiving station places the signal line in the high-impedance state again. The signal line is pulled high again by a pull-up resistor.
- [5] If the transmitting station does not receive an error signal, it proceeds to transmit the next data frame.
If it does receive an error signal, however, it returns to step [2] and retransmits the data in which the error occurred.

Block Transfer Mode: The operation sequence in block transfer mode is as follows.

- [1] When the data line is not in use it is in the high-impedance state, and is fixed high with a pull-up resistor.
- [2] The transmitting station starts transfer of one frame of data. The data frame starts with a start bit (Ds, low-level), followed by 8 data bits (D0 to D7) and a parity bit (Dp).
- [3] With the smart card interface, the data line then returns to the high-impedance state. The data line is pulled high with a pull-up resistor.
- [4] The receiving station carries out a parity check, but does not output an error signal even if an error has occurred. Since subsequent receive operations cannot be carried out if an error occurs, the error flag must be cleared to 0 before the parity bit for the next frame is received.
- [5] The transmitting station proceeds to transmit the next data frame.

13.3.4 Register Settings

Table 13.3 shows a bit map of the registers used by the smart card interface.

Bits indicated as 0 or 1 must be set to the value shown. The setting of other bits is described below.

Table 13.3 Smart Card Interface Register Settings

Register	Bit							
	Bit 7	Bit 6	Bit 5	Bit 4	Bit 3	Bit 2	Bit 1	Bit 0
SMR	GM	BLK	1	O/E	BCP1	BCP0	CKS1	CKS0
BRR	BRR7	BRR6	BRR5	BRR4	BRR3	BRR2	BRR1	BRR0
SCR	TIE	RIE	TE	RE	0	0	CKE1*	CKE0
TDR	TDR7	TDR6	TDR5	TDR4	TDR3	TDR2	TDR1	TDR0
SSR	TDRE	RDRF	ORER	ERS	PER	TEND	0	0
RDR	RDR7	RDR6	RDR5	RDR4	RDR3	RDR2	RDR1	RDR0
SCMR	—	—	—	—	SDIR	SINV	—	SMIF

Notes: — : Unused bit.

* The CKE1 bit must be cleared to 0 when the GM bit in SMR is cleared to 0.

SMR Settings: The GM bit is cleared to 0 in normal smart card interface mode, and set to 1 in GSM mode. The O/E bit is cleared to 0 if the IC card is of the direct convention type, and set to 1 if of the inverse convention type.

Bits CKS1 and CKS0 select the clock source of the built-in baud rate generator, and bits BCP1 and BCP0 select the number of base clock cycles during transfer of one bit. For details, see section 13.3.5, Clock.

The BLK bit is cleared to 0 when using the normal smart card interface mode, and set to 1 when using block transfer mode.

BRR Setting: BRR is used to set the bit rate. See section 13.3.5, Clock, for the method of calculating the value to be set.

SCR Settings: The function of the TIE, RIE, TE, and RE bits is the same as for the normal SCI. For details, see section 12, Serial Communication Interface (SCI).

Bits CKE1 and CKE0 specify the clock output. When the GM bit in SMR is cleared to 0, set these bits to B'00 if a clock is not to be output, or to B'01 if a clock is to be output. When the GM bit in SMR is set to 1, clock output is performed. The clock output can also be fixed high or low.

Smart Card Mode Register (SCMR) Settings: The SDIR bit is cleared to 0 if the IC card is of the direct convention type, and set to 1 if of the inverse convention type.

The SINV bit is cleared to 0 if the IC card is of the direct convention type, and set to 1 if of the inverse convention type.

The SMIF bit is set to 1 when the smart card interface is used.

Examples of register settings and the waveform of the start character are shown below for the two types of IC card (direct convention and inverse convention).

- Direct convention ($SDIR = SINV = O/\bar{E} = 0$)

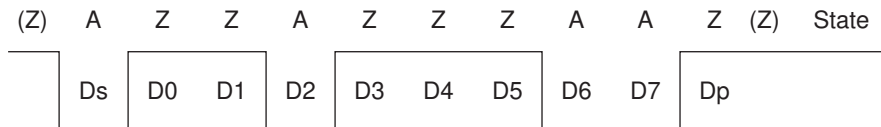

With the direct convention type, the logic 1 level corresponds to state Z and the logic 0 level to state A, and transfer is performed in LSB-first order. The start character data above is H'3B.

The parity bit is 1 since even parity is stipulated for the smart card.

- Inverse convention ($SDIR = SINV = O/\bar{E} = 1$)

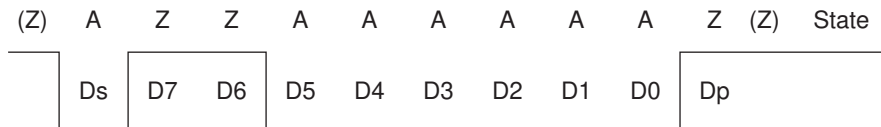

With the inverse convention type, the logic 1 level corresponds to state A and the logic 0 level to state Z, and transfer is performed in MSB-first order. The start character data above is H'3F.

The parity bit is 0, corresponding to state Z, since even parity is stipulated for the smart card.

With the chip, inversion specified by the SINV bit applies only to the data bits, D7 to D0. For parity bit inversion, the O/\bar{E} bit in SMR should be set to odd parity mode (the same applies to both transmission and reception).

13.3.5 Clock

Only an internal clock generated by the built-in baud rate generator can be used as the transmit/receive clock for the smart card interface. The bit rate is set with BRR and the CKS1, CKS0, BCP1, and BCP0 bits in SMR. The formula for calculating the bit rate is as shown below. Table 13.5 shows some sample bit rates.

If clock output is selected by setting CKE0 to 1, the clock is output from the SCK pin. The clock frequency is determined by the bit rate and the setting of bits BCP1 and BCP0.

$$B = \frac{\phi}{S \times 2^{2n+1} \times (N + 1)} \times 10^6$$

Where N = Value set in BRR ($0 \leq N \leq 255$)

B = Bit rate (bits/s)

ϕ = Operating frequency (MHz)

n = See table 13.4

S = Number of internal clock cycles in 1-bit period set by bits BCP1 and BCP0

Table 13.4 Correspondence between n and CKS1, CKS0

n	CKS1	CKS0
0	0	0
1		1
2	1	0
3		1

**Table 13.5 Examples of Bit Rate B (bits/s) for Various BRR Settings
(When n = 0 and S = 372)**

N	ϕ (MHz)							
	10.00	10.714	13.00	14.285	16.00	18.00	20.00	25.00
0	13441	14400	17473	19200	21505	24194	26882	33602
1	6720	7200	8737	9600	10753	12097	13441	16801
2	4480	4800	5824	6400	7168	8065	8961	11201

Note: Bit rates are rounded to the nearest whole number.

The method of calculating the value to be set in the bit rate register (BRR) from the operating frequency and bit rate, on the other hand, is shown below. N is an integer, $0 \leq N \leq 255$, and the smaller error is specified.

$$N = \frac{\phi}{S \times 2^{2n+1} \times B} \times 10^6 - 1$$

Table 13.6 Examples of BRR Settings for Bit Rate B (bits/s) (When n = 0 and S = 372)

Bits/s	ϕ (MHz)																	
	7.1424		10.00		10.7136		13.00		14.2848		16.00		18.00		20.00		25.00	
	N	Error	N	Error	N	Error	N	Error	N	Error	N	Error	N	Error	N	Error	N	Error
9600	0	0.00	1	30	1	25	1	8.99	1	0.00	1	12.01	2	15.99	2	6.60	3	12.49

**Table 13.7 Maximum Bit Rate at Various Frequencies (Smart Card Interface Mode)
(When S = 372)**

ϕ (MHz)	Maximum Bit Rate (bits/s)	N	n
7.1424	9600	0	0
10.00	13441	0	0
10.7136	14400	0	0
13.00	17473	0	0
14.2848	19200	0	0
16.00	21505	0	0
18.00	24194	0	0
20.00	26882	0	0
25.00	33602	0	0

The bit rate error is given by the following formula:

$$\text{Error (\%)} = \left(\frac{\phi}{S \times 2^{2n+1} \times B \times (N + 1)} \times 10^6 - 1 \right) \times 100$$

13.3.6 Data Transfer Operations

Initialization: Before transmitting or receiving data, initialize the SCI as described below. Initialization is also necessary when switching from transmit mode to receive mode, or vice versa.

- [1] Clear the TE and RE bits in SCR to 0.
- [2] Clear the error flags ERS, PER, and ORER in SSR to 0.
- [3] Set the GM, BLK, O/\bar{E} , BCP1, BCP0, CKS1, and CKS0 bits in SMR, and set the PE bit to 1.
- [4] Set the SMIF, SDIR, and SINV bits in SCMR.
When the SMIF bit is set to 1, the TxD and RxD pins are both switched from ports to SCI pins, and are placed in the high-impedance state.
- [5] Set the value corresponding to the bit rate in BRR.
- [6] Set the CKE1 and CKE0 bits in SCR. Clear the TIE, RIE, TE, RE, MPIE, and TEIE bits to 0.
If the CKE0 bit is set to 1, the clock is output from the SCK pin.
- [7] Wait at least one bit interval, then set the TIE, RIE, TE, and RE bits in SCR. Do not set the TE bit and RE bit at the same time, except for self-diagnosis.

Serial Data Transmission (Except Block Transfer Mode): As data transmission in smart card mode involves error signal sampling and retransmission processing, the processing procedure is different from that for the normal SCI. Figure 13.4 shows a flowchart for transmitting, and figure 13.5 shows the relation between a transmit operation and the internal registers.

- [1] Perform smart card interface mode initialization as described above in Initialization.
- [2] Check that the ERS error flag in SSR is cleared to 0.
- [3] Repeat steps [2] and [3] until it can be confirmed that the TEND flag in SSR is set to 1.
- [4] Write the transmit data to TDR, clear the TDRE flag to 0, and perform the transmit operation. The TEND flag is cleared to 0.
- [5] When transmitting data continuously, go back to step [2].
- [6] To end transmission, clear the TE bit to 0.

With the above processing, interrupt handling or data transfer by the DTC is possible.

If transmission ends and the TEND flag is set to 1 while the TIE bit is set to 1 and interrupt requests are enabled, a transmit-data-empty interrupt (TXI) request will be generated. If an error occurs in transmission and the ERS flag is set to 1 while the RIE bit is set to 1 and interrupt requests are enabled, a transmit/receive-error interrupt (ERI) request will be generated.

The timing for setting the TEND flag depends on the value of the GM bit in SMR. The TEND flag setting timing is shown in figure 13.6.

If the DTC is activated by a TXI request, the number of bytes set in the DTC can be transmitted automatically, including automatic retransmission.

For details, see Interrupt Operations and Data Transfer Operation by DTC below.

Note: For details of operation in block transfer mode, see section 12.3.2, Operation in Asynchronous Mode.

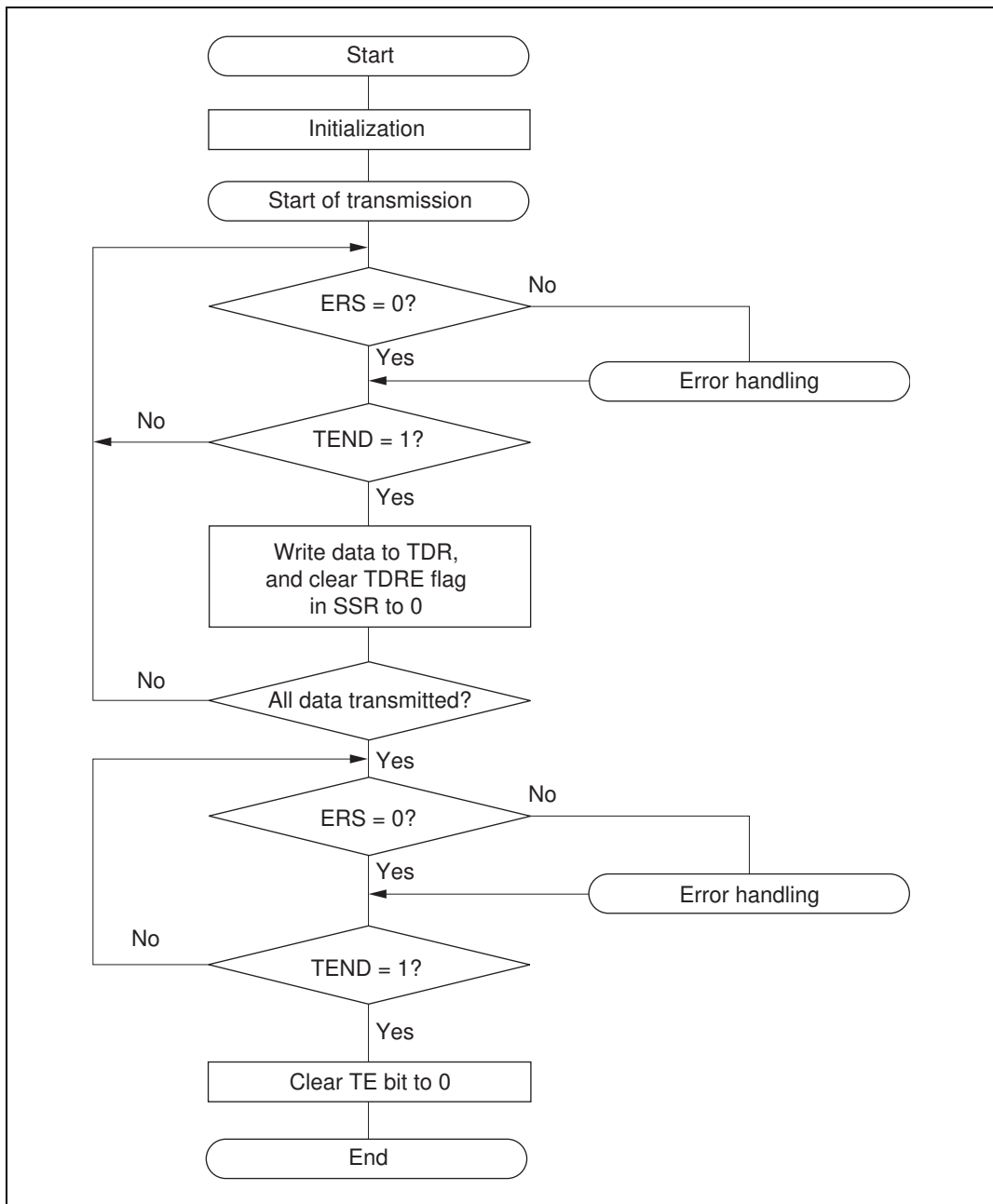

Figure 13.4 Sample Transmission Flowchart

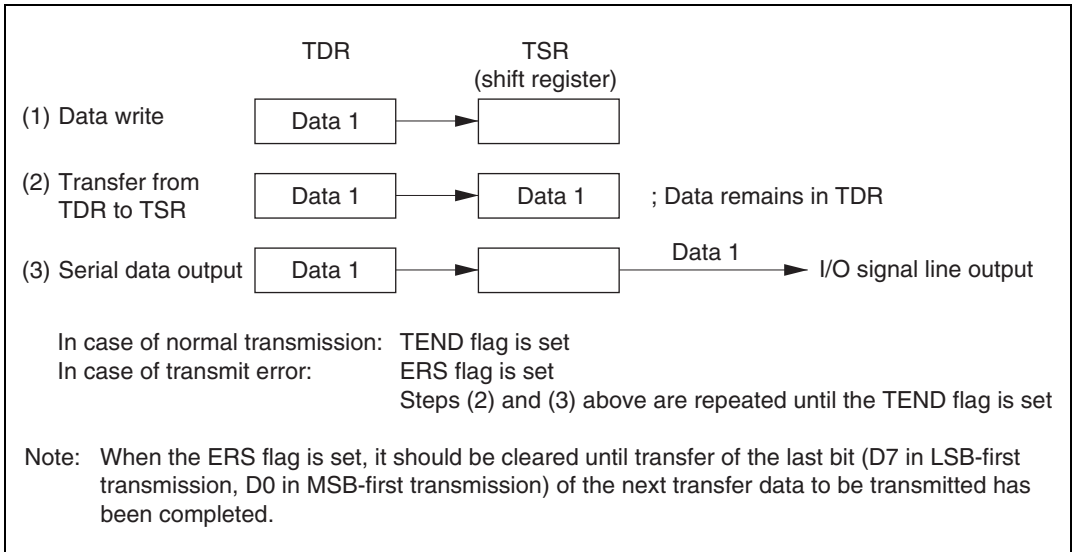

Figure 13.5 Relation Between Transmit Operation and Internal Registers

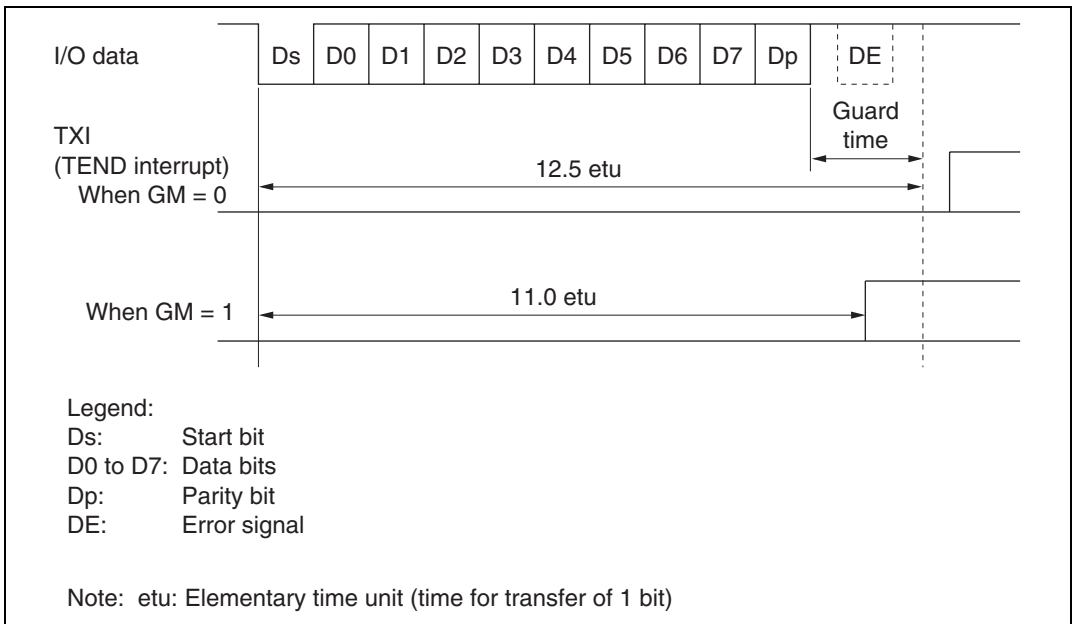

Figure 13.6 TEND Flag Generation Timing in Transmission

Serial Data Reception (Except Block Transfer Mode): Data reception in smart card mode uses the same processing procedure as for the normal SCI. Figure 13.7 shows an example of the transmission processing flow.

- [1] Perform smart card interface mode initialization as described above in Initialization.
- [2] Check that the ORER flag and PER flag in SSR are cleared to 0. If either is set, perform the appropriate receive error handling, then clear both the ORER and the PER flag to 0.
- [3] Repeat steps [2] and [3] until it can be confirmed that the RDRF flag is set to 1.
- [4] Read the receive data from RDR.
- [5] When receiving data continuously, clear the RDRF flag to 0 and go back to step [2].
- [6] To end reception, clear the RE bit to 0.

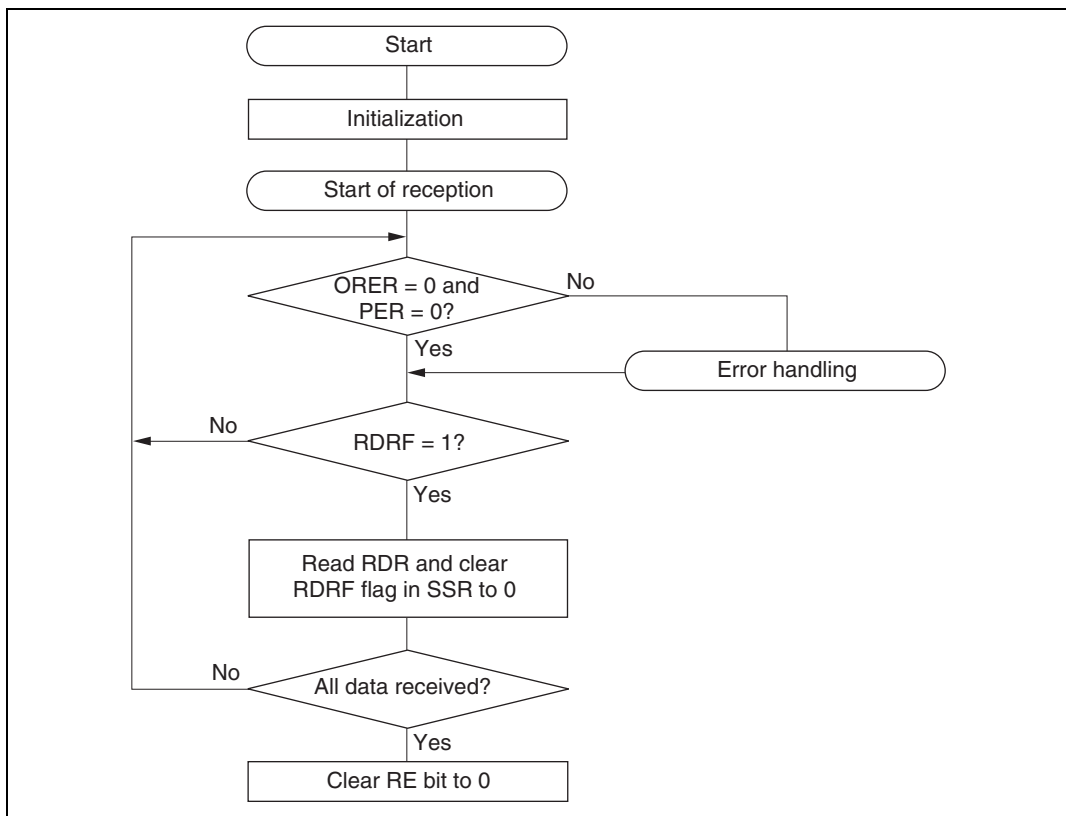

Figure 13.7 Sample Reception Flowchart

With the above processing, interrupt handling or data transfer by the DTC is possible.

If reception ends and the RDRF flag is set to 1 while the RIE bit is set to 1 and interrupt requests are enabled, a receive data full interrupt (RXI) request will be generated. If an error occurs in reception and either the ORER flag or the PER flag is set to 1, a transmit/receive-error interrupt (ERI) request will be generated.

If the DTC is activated by an RXI request, the receive data in which the error occurred is skipped, and only the number of bytes of receive data set in the DTC are transferred.

For details, see Interrupt Operation and Data Transfer Operation by DTC below.

If a parity error occurs during reception and the PER is set to 1, the received data is still transferred to RDR, and therefore this data can be read.

Note: For details of operation in block transfer mode, see section 12.3.2, Operation in Asynchronous Mode.

Mode Switching Operation: When switching from receive mode to transmit mode, first confirm that the receive operation has been completed, then start from initialization, clearing RE bit to 0 and setting TE bit to 1. The RDRF flag or the PER and ORER flags can be used to check that the receive operation has been completed.

When switching from transmit mode to receive mode, first confirm that the transmit operation has been completed, then start from initialization, clearing TE bit to 0 and setting RE bit to 1. The TEND flag can be used to check that the transmit operation has been completed.

Fixing Clock Output: When the GSM bit in SMR is set to 1, the clock output can be fixed with bits CKE1 and CKE0 in SCR. At this time, the minimum clock pulse width can be made the specified width.

Figure 13.8 shows the timing for fixing the clock output. In this example, GSM is set to 1, CKE1 is cleared to 0, and the CKE0 bit is controlled.

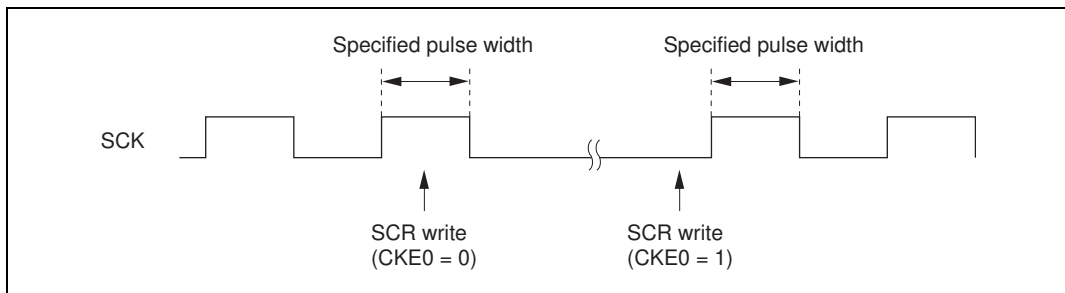

Figure 13.8 Timing for Fixing Clock Output

Interrupt Operation (Except Block Transfer Mode): There are three interrupt sources in smart card interface mode: transmit-data-empty interrupt (TXI) requests, transmit/receive-error interrupt (ERI) requests, and receive-data-full interrupt (RXI) requests. The transmit-end interrupt (TEI) request is not used in this mode.

When the TEND flag in SSR is set to 1, a TXI interrupt request is generated.

When the RDRF flag in SSR is set to 1, an RXI interrupt request is generated.

When any of flags ORER, PER, and ERS in SSR is set to 1, an ERI interrupt request is generated. The relationship between the operating states and interrupt sources is shown in table 13.8.

Note: For details of operation in block transfer mode, see section 12.4, SCI Interrupts.

Table 13.8 Smart Card Mode Operating States and Interrupt Sources

Operating State		Flag	Enable Bit	Interrupt Source	DTC Activation
Transmit Mode	Normal operation	TEND	TIE	TXI	Possible
	Error	ERS	RIE	ERI	Not possible
Receive Mode	Normal operation	RDRF	RIE	RXI	Possible
	Error	PER, ORER	RIE	ERI	Not possible

Data Transfer Operation by DTC: In smart card mode, as with the normal SCI, transfer can be carried out using the DTC. In a transmit operation, the TDRE flag is also set to 1 at the same time as the TEND flag in SSR, and a TXI interrupt is generated. If the TXI request is designated beforehand as a DTC activation source, the DTC will be activated by the TXI request, and transfer of the transmit data will be carried out. The TDRE and TEND flags are automatically cleared to 0 when data transfer is performed by the DTC. In the event of an error, the SCI retransmits the same data automatically. Thus, the number of bytes specified by the SCI is transmitted automatically even in retransmission following an error. However, the ERS flag is not cleared automatically when an error occurs, and so the RIE bit should be set to 1 beforehand so that an ERI request will be generated in the event of an error, and the ERS flag will be cleared.

When performing transfer using the DTC, it is essential to set and enable the DTC before carrying out SCI setting. For details of the DTC setting procedures, see section 7, Data Transfer Controller.

In a receive operation, an RXI interrupt request is generated when the RDRF flag in SSR is set to 1. If the RXI request is designated beforehand as a DTC activation source, the DTC will be activated by the RXI request, and transfer of the receive data will be carried out. The RDRF flag is cleared to 0 automatically when data transfer is performed by the DTC. If an error occurs, an error flag is set but the RDRF flag is not. Consequently, the DTC is not activated, but instead, an ERI interrupt request is sent to the CPU. Therefore, the error flag should be cleared.

Note: For details of operation in block transfer mode, see section 12.4, SCI Interrupts.

13.3.7 Operation in GSM Mode

Switching the Mode: When switching between smart card interface mode and software standby mode, the following switching procedure should be followed in order to maintain the clock duty.

- When changing from smart card interface mode to software standby mode
 - [1] Set the data register (DR) and data direction register (DDR) corresponding to the SCK pin to the value for the fixed output state in software standby mode.
 - [2] Write 0 to the TE bit and RE bit in the serial control register (SCR) to halt the transmit/receive operation. At the same time, set the CKE1 bit to the value for the fixed output state in software standby mode.
 - [3] Write 0 to the CKE0 bit in SCR to halt the clock.
 - [4] Wait for one serial clock period.
During this interval, clock output is fixed at the specified level, with the duty preserved.
 - [5] Write H'00 to SMR and SCMR.
 - [6] Make the transition to the software standby state.
- When returning to smart card interface mode from software standby mode
 - [7] Exit the software standby state.
 - [8] Set the CKE1 bit in SCR to the value for the fixed output state (current SCK pin state) when software standby mode is initiated.
 - [9] Set smart card interface mode and output the clock. Signal generation is started with the normal duty.

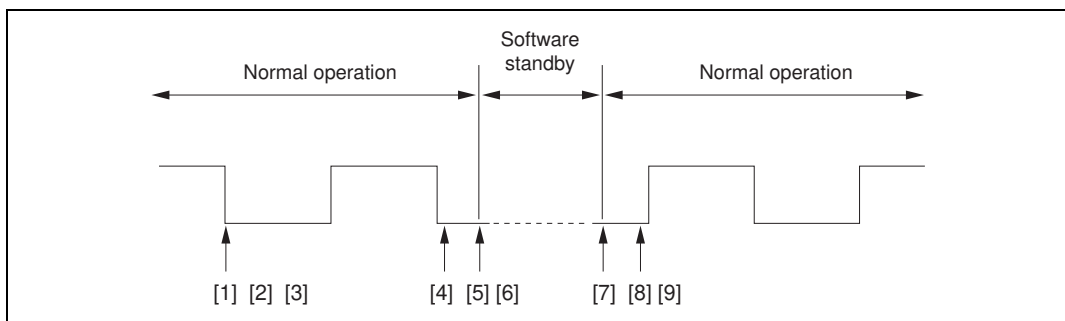

Figure 13.9 Clock Halt and Restart Procedure

Powering On: To secure the clock duty from power-on, the following switching procedure should be followed.

- [1] The initial state is port input and high impedance. Use a pull-up resistor or pull-down resistor to fix the potential.
- [2] Fix the SCK pin to the specified output level with the CKE1 bit in SCR.
- [3] Set SMR and SCMR, and switch to smart card mode operation.
- [4] Set the CKE0 bit in SCR to 1 to start clock output.

13.3.8 Operation in Block Transfer Mode

Operation in block transfer mode is the same as in SCI asynchronous mode, except for the following points. For details, see section 12.3.2, Operation in Asynchronous Mode.

Data Format: The data format is 8 bits with parity. There is no stop bit, but there is a guard time of 2 or more bits (1 or more bits in reception).

Also, except during transmission (with start bit, data bits, and parity bit), the transmission pins go to the high-impedance state, so the signal lines must be fixed high with a pull-up resistor.

Transmit/Receive Clock: Only an internal clock generated by the built-in baud rate generator can be used as the transmit/receive clock. The number of basic clock periods in a 1-bit transfer interval can be set to 32, 64, 372, or 256 with bits BCP1 and BCP0. For details, see section 13.3.5, Clock.

ERS (FER) Flag: As with the normal smart card interface, the ERS flag indicates the error signal status, but since error signal transmission and reception is not performed, this flag is always cleared to 0.

13.4 Usage Notes

The following points should be noted when using the SCI as a smart card interface.

Receive Data Sampling Timing and Receive Margin in Smart Card Interface Mode: In smart card interface mode, the SCI operates on a base clock with a frequency of 32, 64, 372, or 256 times the transfer rate (determined by bits BCP1 and BCP0).

In reception, the SCI samples the falling edge of the start bit using the base clock, and performs internal synchronization. Receive data is latched internally at the rising edge of the 16th, 32nd, 186th, or 128th pulse of the base clock. Use of a 372-times clock is illustrated in figure 13.10.

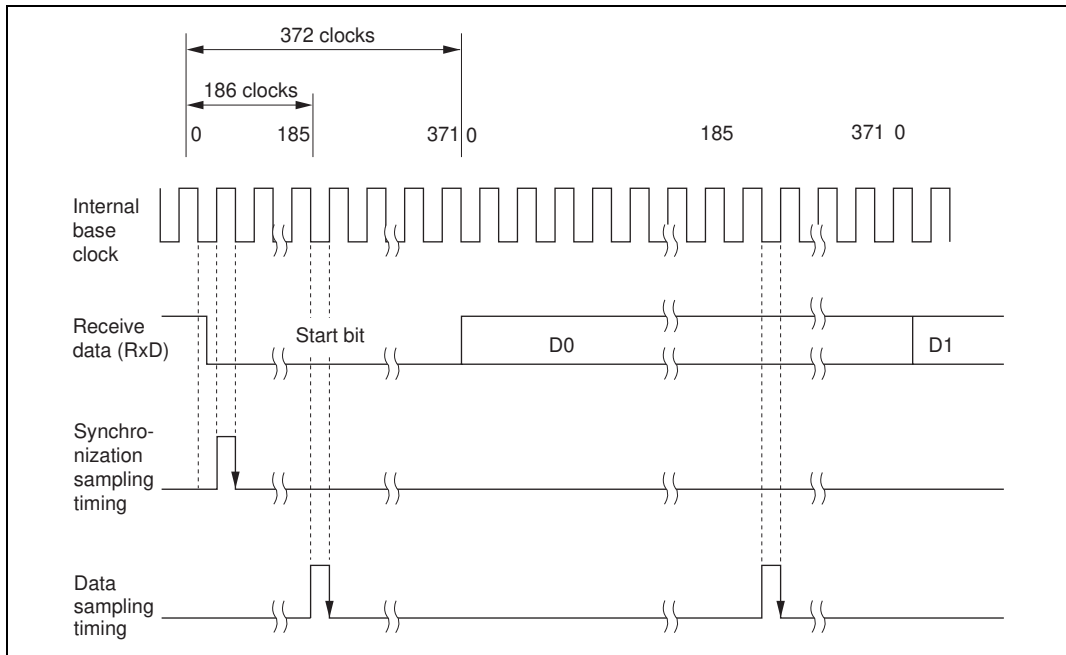

**Figure 13.10 Receive Data Sampling Timing in Smart Card Mode
(When Using 372-Times Clock)**

Thus the receive margin in asynchronous mode is given by the following formula.

$$M = \left| \left(0.5 - \frac{1}{2N} \right) - (L - 0.5) F - \frac{|D - 0.5|}{N} (1 + F) \right| \times 100\%$$

Where M: Receive margin (%)

N: Ratio of bit rate to clock (N = 32, 64, 372, 256)

D: Clock duty (D = 0 to 1.0)

L: Frame length (L = 10)

F: Absolute value of clock frequency deviation

Assuming values of F = 0, D = 0.5, and N=372 in the above formula, the receive margin formula is as follows.

When D = 0.5 and F = 0,

$$\begin{aligned} M &= (0.5 - 1/2 \times 372) \times 100\% \\ &= 49.866\% \end{aligned}$$

Retransfer Operations (Except Block Transfer Mode): Retransfer operations are performed by the SCI in receive mode and transmit mode as described below.

- Retransfer operation when SCI is in receive mode

Figure 13.11 illustrates the retransfer operation when the SCI is in receive mode.

- [1] If an error is found when the received parity bit is checked, the PER bit in SSR is automatically set to 1. If the RIE bit in SCR is enabled at this time, an ERI interrupt request is generated. The PER bit in SSR should be kept cleared to 0 until the next parity bit is sampled.
- [2] The RDRF bit in SSR is not set for a frame in which an error has occurred.
- [3] If no error is found when the received parity bit is checked, the PER bit in SSR is not set.
- [4] If no error is found when the received parity bit is checked, the receive operation is judged to have been completed normally, and the RDRF flag in SSR is automatically set to 1. If the RIE bit in SCR is enabled at this time, an RXI interrupt request is generated.
If DTC data transfer by an RXI source is enabled, the contents of RDR can be read automatically. When the RDR data is read by the DTC, the RDRF flag is automatically cleared to 0.
- [5] When a normal frame is received, the pin retains the high-impedance state at the timing for error signal transmission.

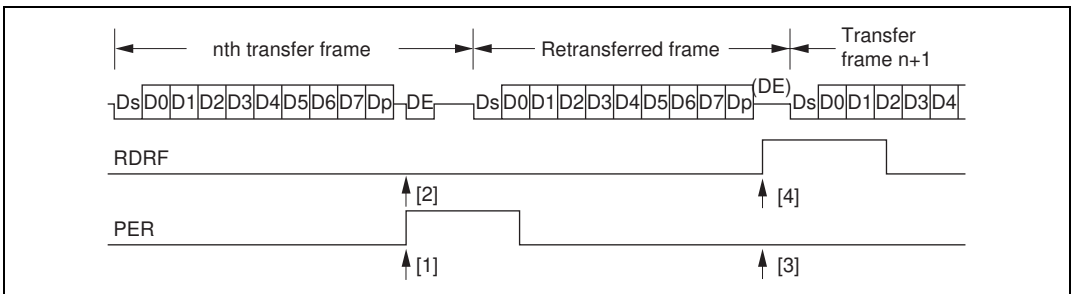

Figure 13.11 Retransfer Operation in SCI Receive Mode

- Retransfer operation when SCI is in transmit mode

Figure 13.12 illustrates the retransfer operation when the SCI is in transmit mode.

- [6] If an error signal is sent back from the receiving end after transmission of one frame is completed, the ERS bit in SSR is set to 1. If the RIE bit in SCR is enabled at this time, an ERI interrupt request is generated. The ERS bit in SSR should be kept cleared to 0 until the next parity bit is sampled.
- [7] The TEND bit in SSR is not set for a frame for which an error signal indicating an abnormality is received.
- [8] If an error signal is not sent back from the receiving end, the ERS bit in SSR is not set.
- [9] If an error signal is not sent back from the receiving end, transmission of one frame, including a retransfer, is judged to have been completed, and the TEND bit in SSR is set to 1. If the TIE bit in SCR is enabled at this time, a TXI interrupt request is generated.

If DTC data transfer by a TXI source is enabled, the next data can be written to TDR automatically. When data is written to TDR by the DTC, the TDRE bit is automatically cleared to 0.

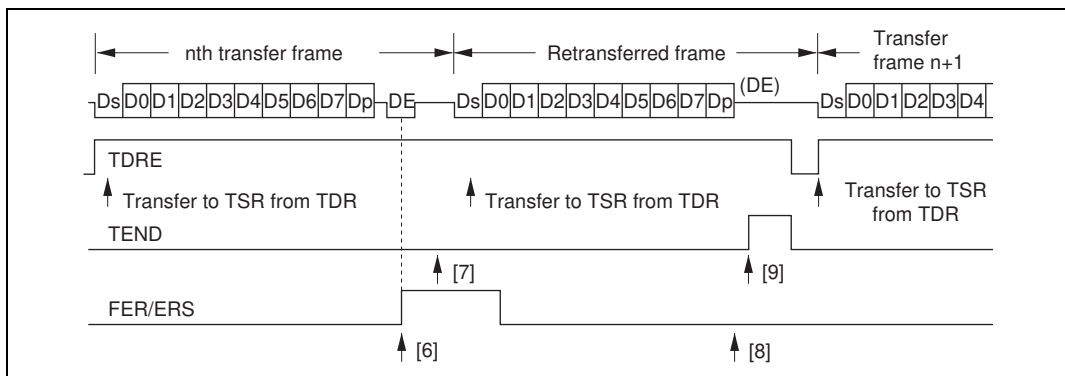

Figure 13.12 Retransfer Operation in SCI Transmit Mode

Section 14 A/D Converter (8 Analog Input Channel Version)

14.1 Overview

The chip incorporates a successive-approximations type 10-bit A/D converter that allows up to eight analog input channels to be selected.

14.1.1 Features

A/D converter features are listed below

- 10-bit resolution
- Eight input channels
- Settable analog conversion voltage range
 - Conversion of analog voltages with the reference voltage pin (V_{ref}) as the analog reference voltage
- High-speed conversion
 - Minimum conversion time: 6.7 μs per channel (at 20-MHz operation)
- Choice of single mode or scan mode
 - Single mode: Single-channel A/D conversion
 - Scan mode: Continuous A/D conversion on 1 to 4 channels
- Four data registers
 - Conversion results are held in a 16-bit data register for each channel
- Sample and hold function
- Three kinds of conversion start
 - Choice of software or timer conversion start trigger (TPU or 8-bit timer), or $\overline{\text{ADTRG}}$ pin
- A/D conversion end interrupt generation
 - A/D conversion end interrupt (ADI) request can be generated at the end of A/D conversion
 - The data transfer controller (DTC) can be activated for data transfer by an interrupt
- Module stop mode can be set
 - As the initial setting, A/D converter operation is halted. Register access is enabled by exiting module stop mode

14.1.2 Block Diagram

Figure 14.1 shows a block diagram of the A/D converter.

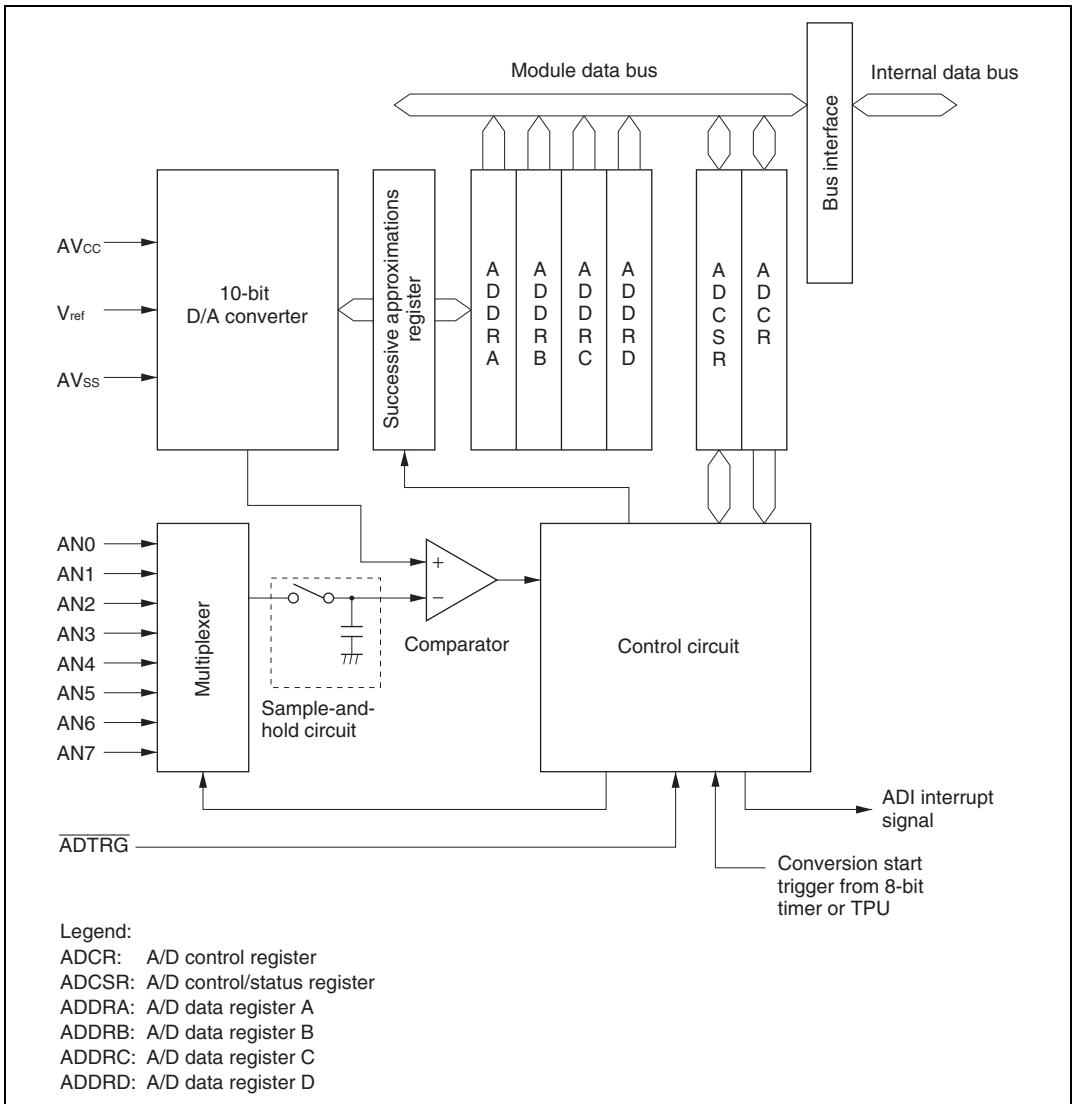

Figure 14.1 Block Diagram of A/D Converter

14.1.3 Pin Configuration

Table 14.1 summarizes the input pins used by the A/D converter.

The AV_{CC} and AV_{SS} pins are the power supply pins for the analog block in the A/D converter. The V_{ref} pin is the A/D conversion reference voltage pin.

The eight analog input pins are divided into two groups: group 0 (AN0 to AN3), and group 1 (AN4 to AN7).

Table 14.1 A/D Converter Pins

Pin Name	Symbol	I/O	Function
Analog power supply pin	AV_{CC}	Input	Analog block power supply
Analog ground pin	AV_{SS}	Input	Analog block ground and A/D conversion reference voltage
Reference voltage pin	V_{ref}	Input	A/D conversion reference voltage
Analog input pin 0	AN0	Input	Group 0 analog inputs
Analog input pin 1	AN1	Input	
Analog input pin 2	AN2	Input	
Analog input pin 3	AN3	Input	
Analog input pin 4	AN4	Input	Group 1 analog inputs
Analog input pin 5	AN5	Input	
Analog input pin 6	AN6	Input	
Analog input pin 7	AN7	Input	
A/D external trigger input pin	\overline{ADTRG}	Input	External trigger input for starting A/D conversion

14.1.4 Register Configuration

Table 14.2 summarizes the registers of the A/D converter.

Table 14.2 A/D Converter Registers

Name	Abbreviation	R/W	Initial Value	Address ^{*1}
A/D data register AH	ADDRAH	R	H'00	H'FF90
A/D data register AL	ADDRAL	R	H'00	H'FF91
A/D data register BH	ADDRBH	R	H'00	H'FF92
A/D data register BL	ADDRBL	R	H'00	H'FF93
A/D data register CH	ADDRCH	R	H'00	H'FF94
A/D data register CL	ADDRCL	R	H'00	H'FF95
A/D data register DH	ADDRDH	R	H'00	H'FF96
A/D data register DL	ADDRDL	R	H'00	H'FF97
A/D control/status register	ADCSR	R/(W) ^{*2}	H'00	H'FF98
A/D control register	ADCR	R/W	H'3F	H'FF99
Module stop control register	MSTPCR	R/W	H'3FFF	H'FF3C

Notes: 1. Lower 16 bits of the address.

2. Bit 7 can only be written with 0 for flag clearing.

14.2 Register Descriptions

14.2.1 A/D Data Registers A to D (ADDRA to ADDR D)

Bit	:	15	14	13	12	11	10	9	8	7	6	5	4	3	2	1	0
		AD9	AD8	AD7	AD6	AD5	AD4	AD3	AD2	AD1	AD0	—	—	—	—	—	—
Initial value :		0	0	0	0	0	0	0	0	0	0	0	0	0	0	0	0
R/W	:	R	R	R	R	R	R	R	R	R	R	R	R	R	R	R	R

There are four 16-bit read-only ADDR registers, ADDRA to ADDR D, used to store the results of A/D conversion.

The 10-bit data resulting from A/D conversion is transferred to the ADDR register for the selected channel and stored there. The upper 8 bits of the converted data are transferred to the upper byte (bits 15 to 8) of ADDR, and the lower 2 bits are transferred to the lower byte (bits 7 and 6) and stored. Bits 5 to 0 are always read as 0.

The correspondence between the analog input channels and ADDR registers is shown in table 14.3.

The ADDR registers can always be read by the CPU. The upper byte can be read directly, but for the lower byte, data transfer is performed via a temporary register (TEMP). For details, see section 14.3, Interface to Bus Master.

The ADDR registers are initialized to H'0000 by a reset, and in standby mode or module stop mode.

Table 14.3 Analog Input Channels and Corresponding ADDR Registers

Analog Input Channel		A/D Data Register
Group 0	Group 1	
AN0	AN4	ADDRA
AN1	AN5	ADDRB
AN2	AN6	ADDRC
AN3	AN7	ADDRD

14.2.2 A/D Control/Status Register (ADCSR)

Bit	:	7	6	5	4	3	2	1	0
		ADF	ADIE	ADST	SCAN	CKS	CH2	CH1	CH0
Initial value :		0	0	0	0	0	0	0	0
R/W	:	R/(W)*	R/W	R/W	R/W	R/W	R/W	R/W	R/W

Note: * Only 0 can be written to bit 7, to clear this flag.

ADCSR is an 8-bit readable/writable register that controls A/D conversion operations and shows the status of the operation.

ADCSR is initialized to H'00 by a reset, and in standby mode or module stop mode.

Bit 7—A/D End Flag (ADF): Status flag that indicates the end of A/D conversion.

Bit 7

ADF	Description	
0	[Clearing conditions]	(Initial value)
	<ul style="list-style-type: none"> When 0 is written to the ADF flag after reading ADF = 1 When the DTC is activated by an ADI interrupt and ADDR is read 	
1	[Setting conditions]	
	<ul style="list-style-type: none"> Single mode: When A/D conversion ends Scan mode: When A/D conversion ends on all specified channels 	

Bit 6—A/D Interrupt Enable (ADIE): Selects enabling or disabling of interrupt (ADI) requests at the end of A/D conversion.

Bit 6

ADIE	Description	
0	A/D conversion end interrupt (ADI) request disabled	(Initial value)
1	A/D conversion end interrupt (ADI) request enabled	

Bit 5—A/D Start (ADST): Selects starting or stopping of A/D conversion. Holds a value of 1 during A/D conversion.

The ADST bit can be set to 1 by software, a timer conversion start trigger, or the A/D external trigger input pin (ADTRG).

Bit 5

ADST	Description
0	A/D conversion stopped (Initial value)
1	<ul style="list-style-type: none"> • Single mode A/D conversion is started. Cleared to 0 automatically when conversion on the specified channel ends • Scan mode A/D conversion is started. Conversion continues sequentially on the selected channels until ADST is cleared to 0 by software, a reset, or a transition to standby mode or module stop mode

Bit 4—Scan Mode (SCAN): Selects single mode or scan mode as the A/D conversion operating mode. See section 14.4, Operation, for details of single mode and scan mode operation. Only set the SCAN bit while conversion is stopped (ADST = 0).

Bit 4

SCAN	Description
0	Single mode (Initial value)
1	Scan mode

Bit 3—Clock Select (CKS): Used together with the CKS1 bit in ADCR to set the A/D conversion time. Only change the conversion time while conversion is stopped (ADST = 0).

ADCR3 CKS1	Bit 3 CKS	Description
0	0	Conversion time = 530 states (max.)
	1	Conversion time = 68 states (max.)
1	0	Conversion time = 266 states (max.) (Initial value)
	1	Conversion time = 134 states (max.)

Bits 2 to 0—Channel Select 2 to 0 (CH2 to CH0): These bits are used together with the SCAN bit to select the analog input channels.

Only set the input channel(s) while conversion is stopped (ADST = 0).

Group Selection	Channel Selection		Description	
	CH2	CH1	CH0	Single Mode (SCAN = 0) Scan Mode (SCAN = 1)
0	0	0	AN0 (Initial value)	AN0
		1	AN1	AN0, AN1
	1	0	AN2	AN0 to AN2
		1	AN3	AN0 to AN3
1	0	0	AN4	AN4
		1	AN5	AN4, AN5
	1	0	AN6	AN4 to AN6
		1	AN7	AN4 to AN7

14.2.3 A/D Control Register (ADCR)

Bit	7	6	5	4	3	2	1	0
	TRGS1	TRGS0	—	—	CKS1	—	—	—
Initial value :	0	0	1	1	1	1	1	1
R/W :	R/W	R/W	—	—	R/W	R/W	—	—

ADCR is an 8-bit readable/writable register that enables or disables external triggering of A/D conversion operations.

ADCR is initialized to H'3F by a reset, and in standby mode or module stop mode.

Bits 7 and 6—Timer Trigger Select 1 and 0 (TRGS1, TRGS0): These bits select enabling or disabling of the start of A/D conversion by a trigger signal. Only set bits TRGS1 and TRGS0 while conversion is stopped (ADST = 0).

Bit 7 TRGS1	Bit 6 TRGS0	Description
0	0	A/D conversion start by external trigger is disabled (Initial value)
	1	A/D conversion start by external trigger (TPU) is enabled
1	0	A/D conversion start by external trigger (8-bit timer) is enabled
	1	A/D conversion start by external trigger pin ($\overline{\text{ADTRG}}$) is enabled

Bits 5, 4, 1, and 0—Reserved: These bits cannot be modified and are always read as 1.

Bit 3—Clock Select 1 (CKS1): Used together with the CKS bit in ADCSR to set the A/D conversion time. See the description of the CKS bit for details.

Bit 2—Reserved: A value of 1 must be written to this bit.

14.2.4 Module Stop Control Register (MSTPCR)

MSTPCRH								MSTPCRL								
Bit	15	14	13	12	11	10	9	8	7	6	5	4	3	2	1	0
Initial value :	0	0	1	1	1	1	1	1	1	1	1	1	1	1	1	1
R/W :	R/W	R/W	R/W	R/W	R/W	R/W	R/W	R/W	R/W	R/W	R/W	R/W	R/W	R/W	R/W	R/W

MSTPCR is a 16-bit readable/writable register that performs module stop mode control.

When the MSTP9 bit in MSTPCR is set to 1, A/D converter operation stops at the end of the bus cycle and a transition is made to module stop mode. Registers cannot be read or written to in module stop mode. For details, see section 19.5, Module Stop Mode.

MSTPCR is initialized to H'3FFF by a reset and in hardware standby mode. It is not initialized in software standby mode.

Bit 9—Module Stop (MSTP9): Specifies the A/D converter module stop mode.

Bit 9 MSTP9	Description
0	A/D converter module stop mode cleared
1	A/D converter module stop mode set (Initial value)

14.3 Interface to Bus Master

ADDRA to ADDRD are 16-bit registers, and the data bus to the bus master is 8 bits wide. Therefore, in accesses by the bus master, the upper byte is accessed directly, but the lower byte is accessed via a temporary register (TEMP).

A data read from ADDR is performed as follows. When the upper byte is read, the upper byte value is transferred to the CPU and the lower byte value is transferred to TEMP. Next, when the lower byte is read, the TEMP contents are transferred to the CPU.

When reading ADDR, always read the upper byte before the lower byte. It is possible to read only the upper byte, but if only the lower byte is read, incorrect data may be obtained.

Figure 14.2 shows the data flow for ADDR access.

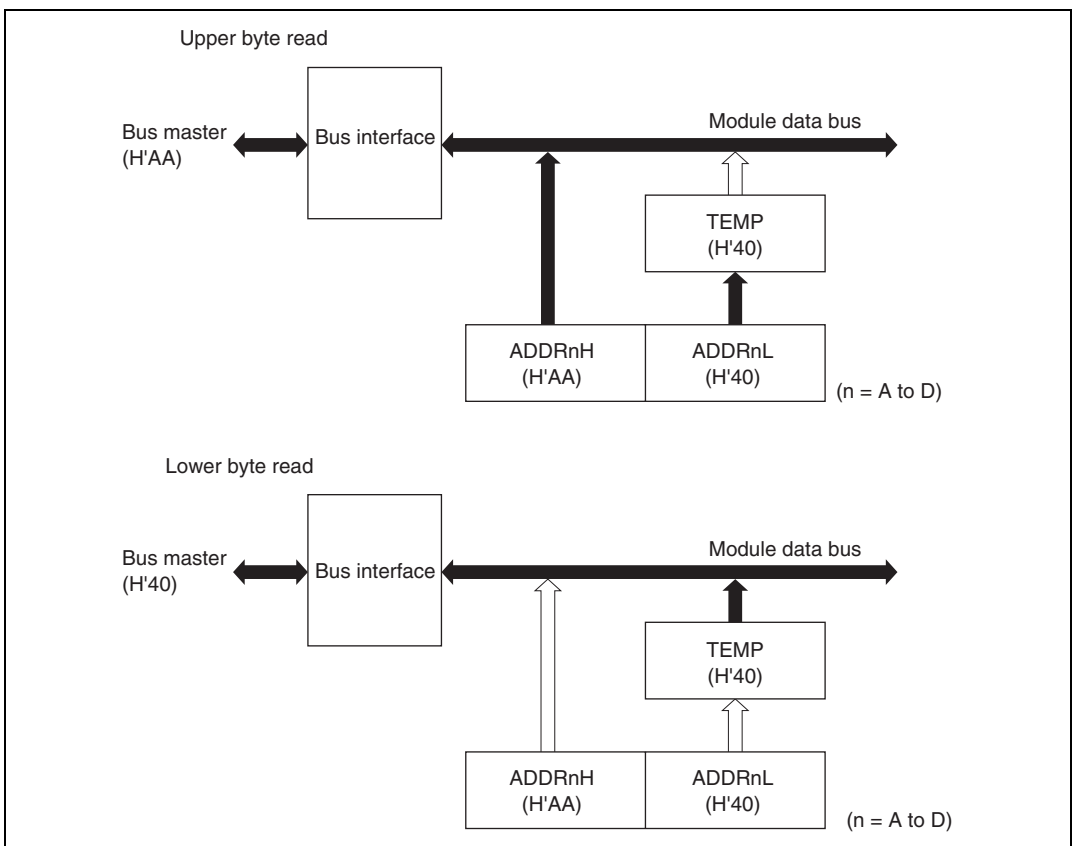

Figure 14.2 ADDR Access Operation (Reading H'AA40)

14.4 Operation

The A/D converter operates by successive approximations with 10-bit resolution. It has two operating modes: single mode and scan mode.

14.4.1 Single Mode (SCAN = 0)

Single mode is selected when A/D conversion is to be performed on a single channel only. A/D conversion is started when the ADST bit is set to 1 by software or by external trigger input. The ADST bit remains set to 1 during A/D conversion, and is automatically cleared to 0 when conversion ends.

On completion of conversion, the ADF flag is set to 1. If the ADIE bit is set to 1 at this time, an ADI interrupt request is generated. The ADF flag is cleared by writing 0 to it after reading ADCSR.

When the operating mode or analog input channel must be changed during analog conversion, to prevent incorrect operation, first clear the ADST bit to 0 in ADCSR to halt A/D conversion. After making the necessary changes, set the ADST bit to 1 to start A/D conversion again. The ADST bit can be set at the same time as the operating mode or input channel is changed.

Typical operations when channel 1 (AN1) is selected in single mode are described next. Figure 14.3 shows a timing diagram for this example.

- [1] Single mode is selected (SCAN = 0), input channel AN1 is selected (CH2 = 0, CH1 = 0, CH0 = 1), the A/D interrupt is enabled (ADIE = 1), and A/D conversion is started (ADST = 1).
- [2] When A/D conversion is completed, the result is transferred to ADDR0. At the same time the ADF flag is set to 1, the ADST bit is cleared to 0, and the A/D converter becomes idle.
- [3] Since ADF = 1 and ADIE = 1, an ADI interrupt is requested.
- [4] The A/D interrupt handling routine starts.
- [5] The routine reads ADCSR, then writes 0 to the ADF flag.
- [6] The routine reads and processes the conversion result (ADDR0).
- [7] Execution of the A/D interrupt handling routine ends. After that, if the ADST bit is set to 1, A/D conversion starts again and steps [2] to [7] are repeated.

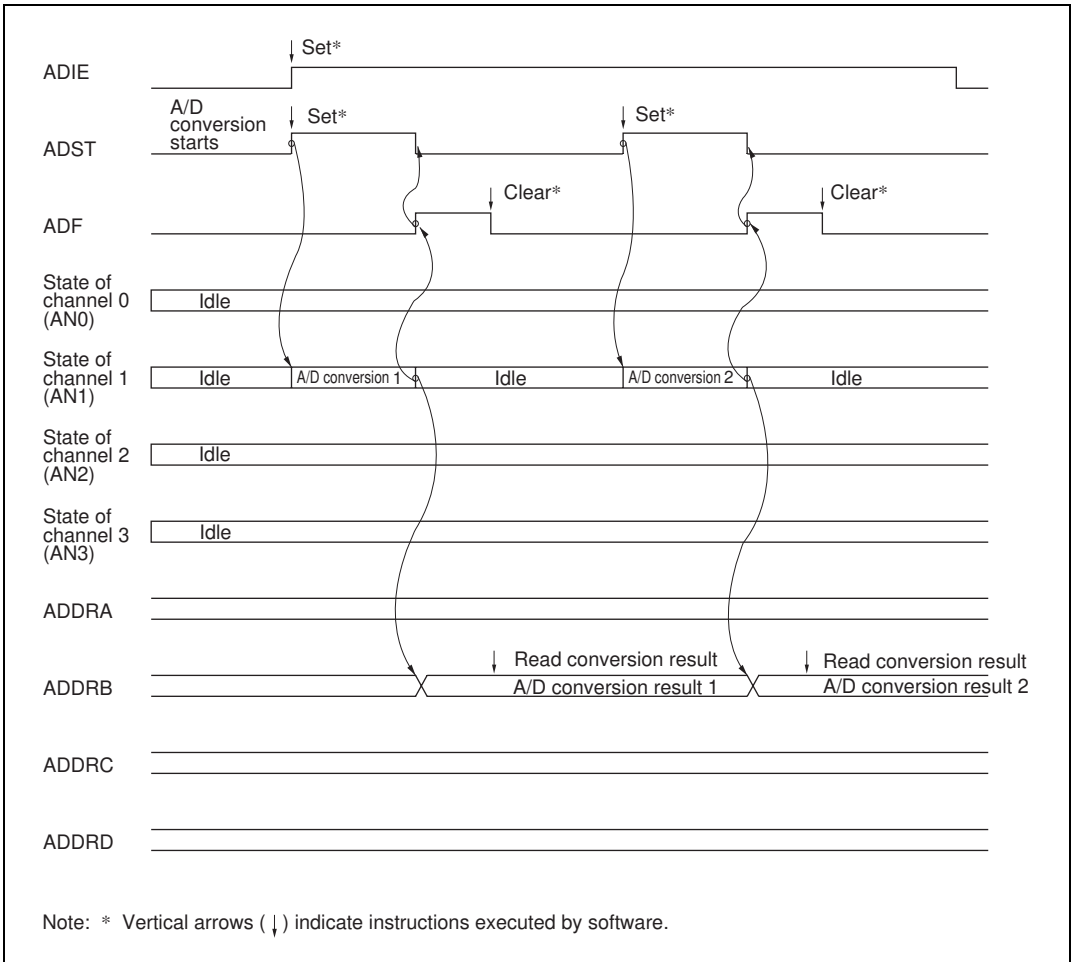

Figure 14.3 Example of A/D Converter Operation (Single Mode, Channel 1 Selected)

14.4.2 Scan Mode (SCAN = 1)

Scan mode is useful for monitoring analog inputs in a group of one or more channels. When the ADST bit is set to 1 by software, or by timer or external trigger input, A/D conversion starts on the first channel in the group (AN0). When two or more channels are selected, after conversion of the first channel ends, conversion of the second channel (AN1) starts immediately. A/D conversion continues cyclically on the selected channels until the ADST bit is cleared to 0. The conversion results are transferred for storage into the ADDR registers corresponding to the channels.

When the operating mode or analog input channel must be changed during analog conversion, to prevent incorrect operation, first clear the ADST bit to 0 in ADCSR to halt A/D conversion. After making the necessary changes, set the ADST bit to 1 to start A/D conversion again. The ADST bit can be set at the same time as the operating mode or input channel is changed.

Typical operations when three channels (AN0 to AN2) are selected in scan mode are described next. Figure 14.4 shows a timing diagram for this example.

- [1] Scan mode is selected (SCAN = 1), scan group 0 is selected (CH2 = 0), analog input channels AN0 to AN2 are selected (CH1 = 1, CH0 = 0), and A/D conversion is started (ADST = 1)
- [2] When A/D conversion of the first channel (AN0) is completed, the result is transferred to ADDR0. Next, conversion of the second channel (AN1) starts automatically.
- [3] Conversion proceeds in the same way through the third channel (AN2).
- [4] When conversion of all the selected channels (AN0 to AN2) is completed, the ADF flag is set to 1 and conversion of the first channel (AN0) starts again. If the ADIE bit is set to 1 at this time, an ADI interrupt is requested after A/D conversion ends.
- [5] Steps [2] to [4] are repeated as long as the ADST bit remains set to 1. When the ADST bit is cleared to 0, A/D conversion stops. After that, if the ADST bit is set to 1, A/D conversion starts again from the first channel (AN0).

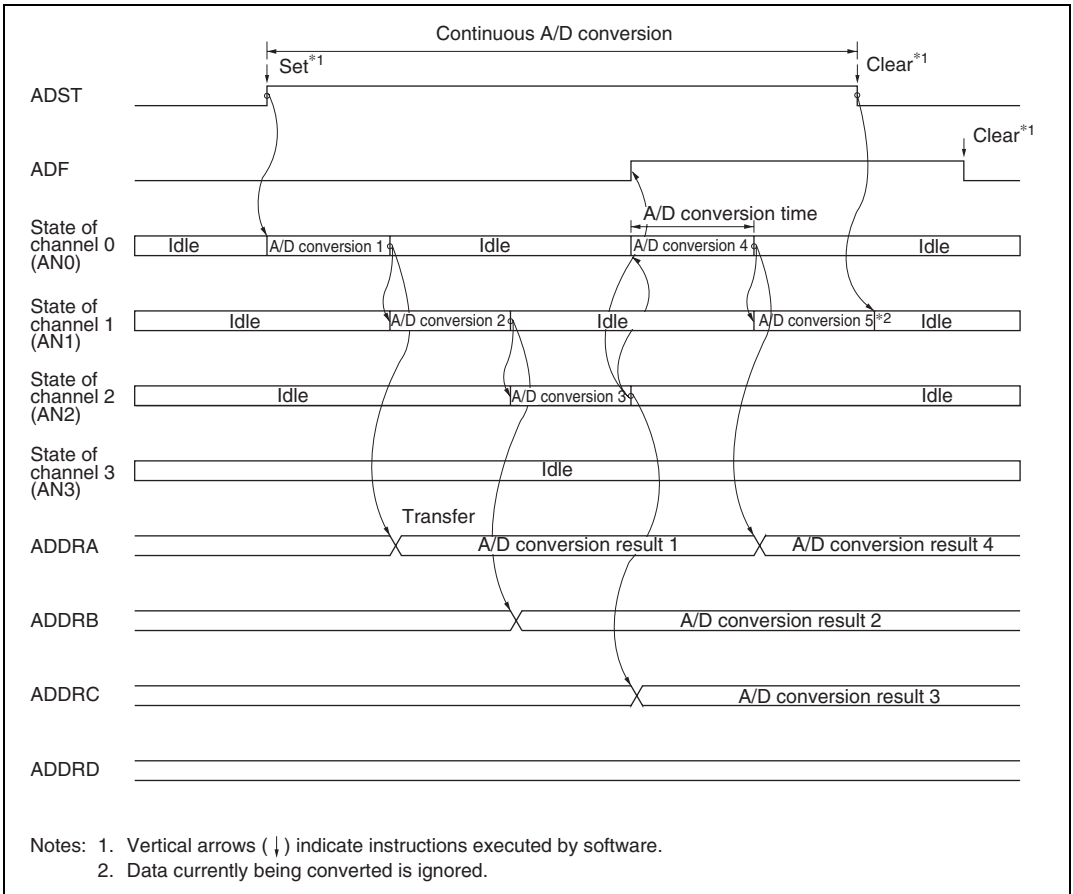

**Figure 14.4 Example of A/D Converter Operation
(Scan Mode, Channels AN0 to AN2 Selected)**

14.4.3 Input Sampling and A/D Conversion Time

The A/D converter has a built-in sample-and-hold circuit. The A/D converter samples the analog input at a time t_D after the ADST bit is set to 1, then starts conversion. Figure 14.5 shows the A/D conversion timing. Table 14.4 indicates the A/D conversion time.

As indicated in figure 14.5, the A/D conversion time includes t_D and the input sampling time. The length of t_D varies depending on the timing of the write access to ADCSR. The total conversion time therefore varies within the ranges indicated in table 14.4.

In scan mode, the values given in table 14.4 apply to the first conversion time. In the second and subsequent conversions the conversion time is as shown in table 14.5.

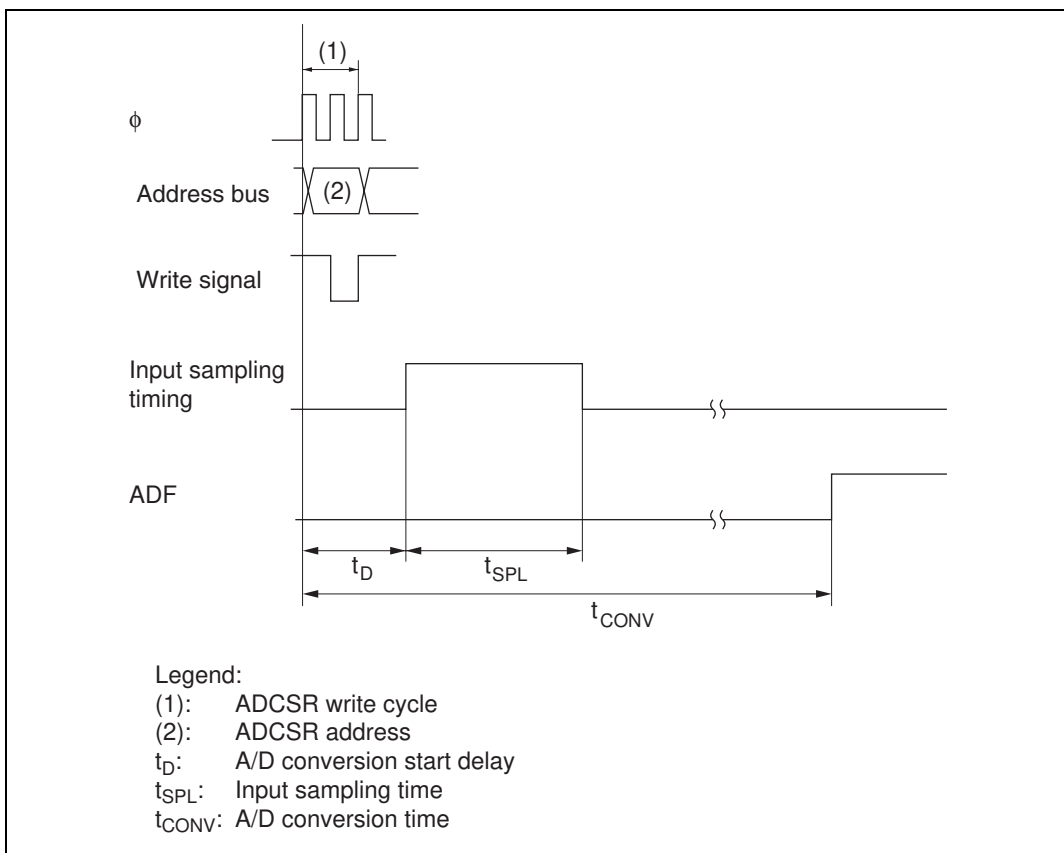

Figure 14.5 A/D Conversion Timing

Table 14.4 A/D Conversion Time (Single Mode)

Item	Symbol	CKS1 = 0						CKS1 = 1					
		CKS = 0			CKS = 1			CKS = 0			CKS = 1		
		Min	Typ	Max	Min	Typ	Max	Min	Typ	Max	Min	Typ	Max
A/D conversion start delay	t_D	18	—	33	4	—	5	10	—	17	6	—	9
Input sampling time	t_{SPL}	—	127	—	—	15	—	—	63	—	—	31	—
A/D conversion time	t_{CONV}	515	—	530	67	—	68	259	—	266	131	—	134

Note: Values in the table are the number of states.

Table 14.5 A/D Conversion Time (Scan Mode)

CKS1	CKS	Conversion Time (States)
0	0	512 (Fixed)
	1	64 (Fixed)
1	0	256 (Fixed)
	1	128 (Fixed)

14.4.4 External Trigger Input Timing

A/D conversion can be externally triggered. When the TRGS1 and TRGS0 bits are set to B'11 in ADCR, external trigger input is enabled at the \overline{ADTRG} pin. A falling edge at the \overline{ADTRG} pin sets the ADST bit to 1 in ADCSR, starting A/D conversion. Other operations, in both single and scan modes, are the same as when the ADST bit has been set to 1 by software. Figure 14.6 shows the timing.

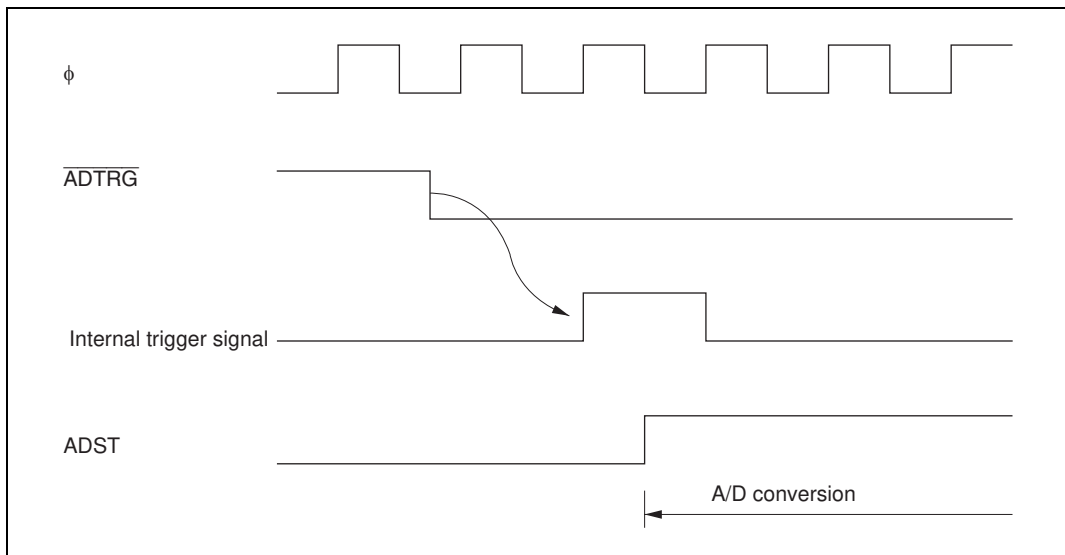

Figure 14.6 External Trigger Input Timing

14.5 Interrupts

The A/D converter generates an A/D conversion end interrupt (ADI) at the end of A/D conversion. ADI interrupt requests can be enabled or disabled by means of the ADIE bit in ADCSR.

The DTC can be activated by an ADI interrupt. Having the converted data read by the DTC in response to an ADI interrupt enables continuous conversion to be achieved without imposing a load on software.

The A/D converter interrupt source is shown in table 14.6.

Table 14.6 A/D Converter Interrupt Source

Interrupt Source	Description	DTC Activation
ADI	Interrupt due to end of conversion	Possible

14.6 Usage Notes

The following points should be noted when using the A/D converter.

Setting Range of Analog Power Supply and Other Pins

1. Analog input voltage range

The voltage applied to analog input pins ANn during A/D conversion should be in the range $AV_{SS} \leq ANn \leq V_{ref}$.

2. Relation between AV_{CC} , AV_{SS} and V_{CC} , V_{SS}

As the relationship between AV_{CC} , AV_{SS} and V_{CC} , V_{SS} , set $AV_{SS} = V_{SS}$. If the A/D converter is not used, the AV_{CC} and AV_{SS} pins must not be left open.

3. V_{ref} input range

The analog reference voltage input at the V_{ref} pin should be set in the range $V_{ref} \leq AV_{CC}$. The V_{ref} pin should be set as $V_{ref} = V_{CC}$ when the A/D converter is not used. Do not leave the V_{ref} pin open.

If conditions 1, 2, and 3 above are not met, the reliability of the device may be adversely affected.

Notes on Board Design: In board design, digital circuitry and analog circuitry should be as mutually isolated as possible, and layout in which digital circuit signal lines and analog circuit signal lines cross or are in close proximity should be avoided as far as possible. Failure to do so may result in incorrect operation of the analog circuitry due to inductance, adversely affecting A/D conversion values.

Also, digital circuitry must be isolated from the analog input signals (AN0 to AN7), analog reference power supply (V_{ref}), and analog power supply (AV_{CC}) by the analog ground (AV_{SS}). Also, the analog ground (AV_{SS}) should be connected at one point to a stable digital ground (V_{SS}) on the board.

Notes on Noise Countermeasures: A protection circuit connected to prevent damage due to an abnormal voltage such as an excessive surge at the analog input pins (AN0 to AN7) and analog reference power supply (V_{ref}) should be connected between AV_{CC} and AV_{SS} as shown in figure 14.7.

Also, the bypass capacitors connected to AV_{CC} and V_{ref} and the filter capacitor connected to AN0 to AN7 must be connected to AV_{SS} .

If a filter capacitor is connected as shown in figure 14.7, the input currents at the analog input pins (AN0 to AN7) are averaged, and so an error may arise. Also, when A/D conversion is performed

frequently, as in scan mode, if the current charged and discharged by the capacitance of the sample-and-hold circuit in the A/D converter exceeds the current input via the input impedance (R_{in}), an error will arise in the analog input pin voltage. Careful consideration is therefore required when deciding the circuit constants.

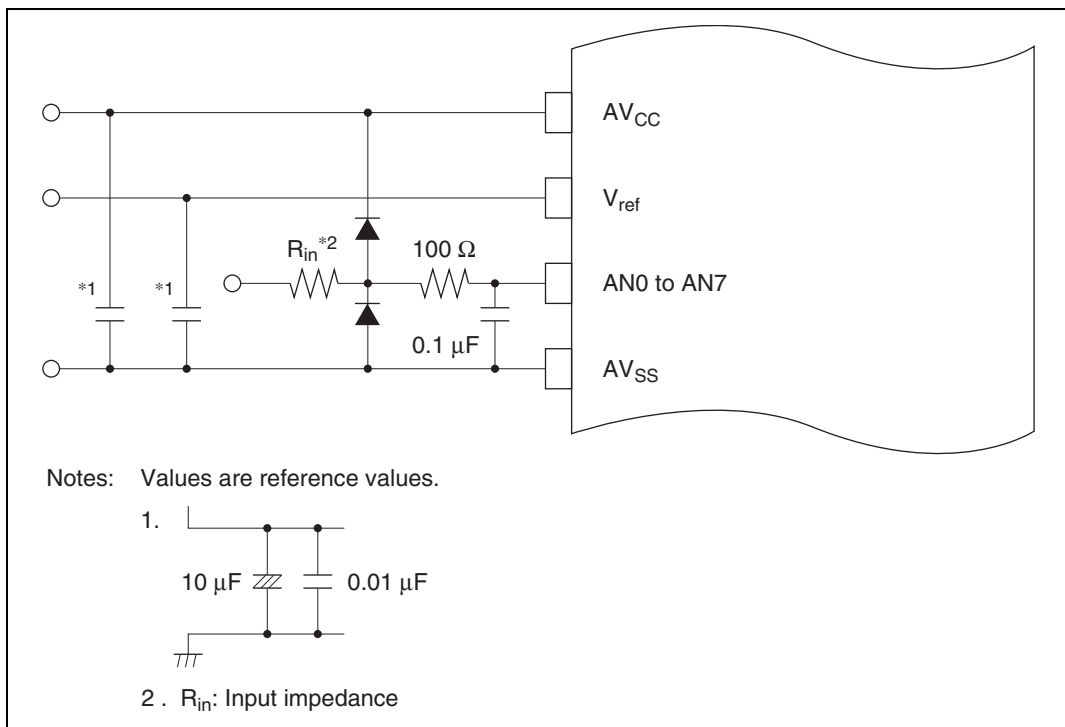

Figure 14.7 Example of Analog Input Protection Circuit

A/D Conversion Precision Definitions: The chip's A/D conversion precision definitions are given below.

- **Resolution**
The number of A/D converter digital output codes.
- **Offset error**
The deviation of the analog input voltage value from the ideal A/D conversion characteristic when the digital output changes from the minimum voltage value B'0000000000 to B'0000000001 (see figure 14.9).
- **Full-scale error**
The deviation of the analog input voltage value from the ideal A/D conversion characteristic when the digital output changes from B'1111111110 to B'1111111111 (see figure 14.9).
- **Quantization error**
The deviation inherent in the A/D converter, given by 1/2 LSB (see figure 14.8).
- **Nonlinearity error**
The error with respect to the ideal A/D conversion characteristic between the zero voltage and the full-scale voltage. Does not include the offset error, full-scale error, or quantization error.
- **Absolute precision**
The deviation between the digital value and the analog input value. Includes the offset error, full-scale error, quantization error, and nonlinearity error.

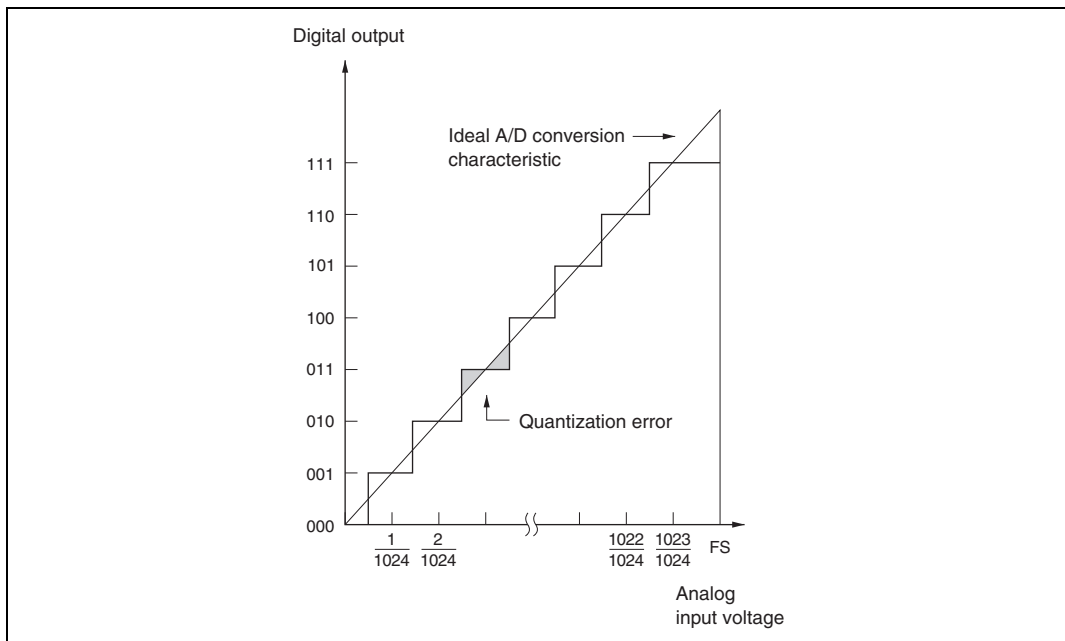

Figure 14.8 A/D Conversion Precision Definitions (1)

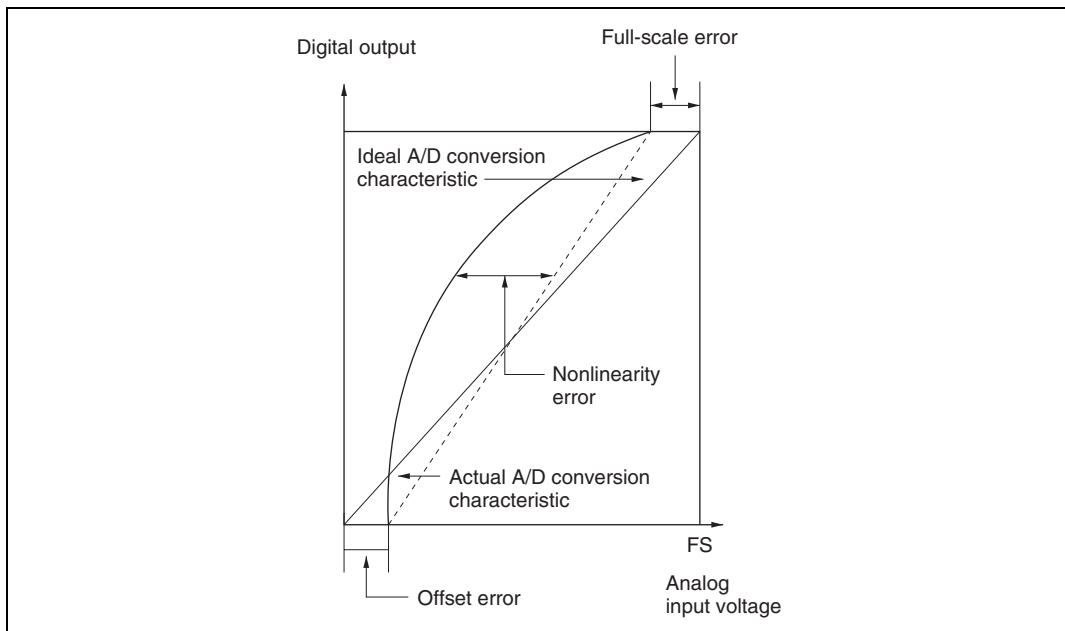

Figure 14.9 A/D Conversion Precision Definitions (2)

Permissible Signal Source Impedance: The chip's analog input is designed so that conversion precision is guaranteed for an input signal for which the signal source impedance is 5 k Ω or less. This specification is provided to enable the A/D converter's sample-and-hold circuit input capacitance to be charged within the sampling time; if the sensor output impedance exceeds 5 k Ω , charging may be insufficient and it may not be possible to guarantee the A/D conversion precision.

If a large capacitance is provided externally, the input load will essentially comprise only the internal input resistance of 10 k Ω , and the signal source impedance is ignored. However, since a low-pass filter effect is obtained in this case, it may not be possible to follow an analog signal with a large differential coefficient (e.g., 5 mV/ μ s or greater).

When converting a high-speed analog signal, a low-impedance buffer should be inserted.

Influences on Absolute Precision: Adding capacitance results in coupling with GND, and therefore noise in GND may adversely affect absolute precision. Be sure to make the connection to an electrically stable GND such as AV_{SS}.

Care is also required to insure that filter circuits do not communicate with digital signals on the mounting board, so acting as antennas.

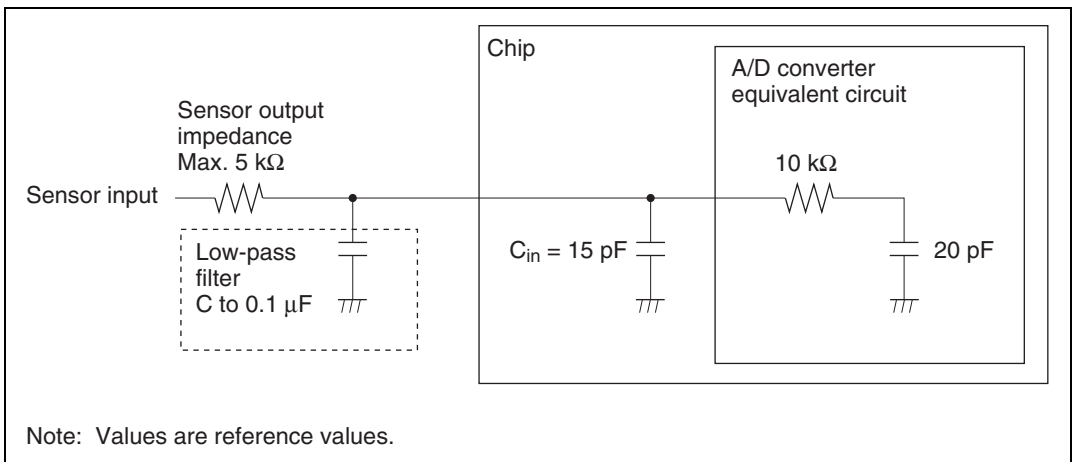

Figure 14.10 Example of Analog Input Circuit

Section 15 D/A Converter

15.1 Overview

The chip includes an 8-bit resolution D/A converter with two analog signal output channels.

15.1.1 Features

D/A converter features are listed below.

- 8-bit resolution
- Two output channels
- Maximum conversion time of 10 μ s (with 20-pF load)
- Output voltage of 0 V to V_{ref}
- D/A output hold function in software standby mode
- Module stop mode can be set
 - As the initial setting, D/A converter operation is halted. Register access is enabled by exiting module stop mode.

15.1.2 Block Diagram

Figure 15.1 shows a block diagram of the D/A converter.

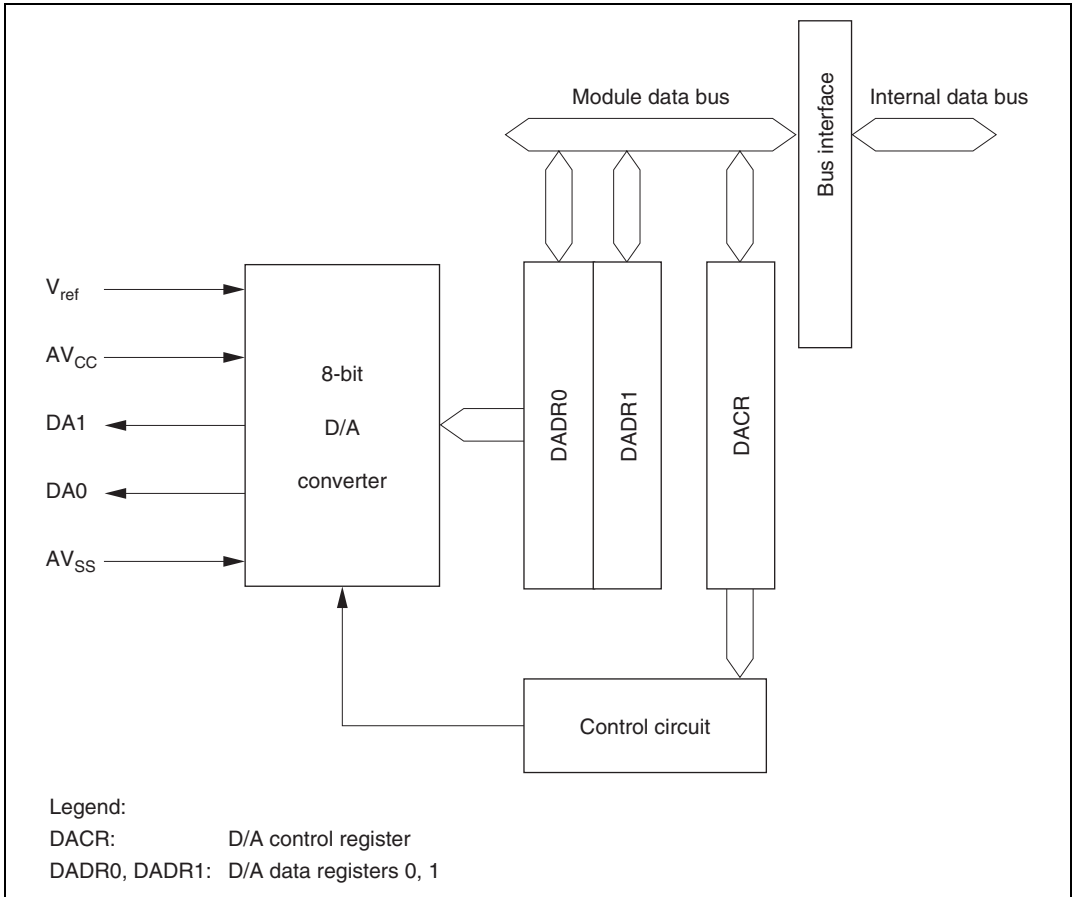

Figure 15.1 Block Diagram of D/A Converter

15.1.3 Pin Configuration

Table 15.1 summarizes the input and output pins of the D/A converter.

Table 15.1 Pin Configuration

Pin Name	Symbol	I/O	Function
Analog power pin	AV_{CC}	Input	Analog power source
Analog ground pin	AV_{SS}	Input	Analog ground and reference voltage
Analog output pin 0	DA0	Output	Channel 0 analog output
Analog output pin 1	DA1	Output	Channel 1 analog output
Reference voltage pin	V_{ref}	Input	Analog reference voltage

15.1.4 Register Configuration

Table 15.2 summarizes the registers of the D/A converter.

Table 15.2 D/A Converter Registers

Channels	Name	Abbreviation	R/W	Initial Value	Address*
0, 1	D/A data register 0	DADR0	R/W	H'00	H'FFA4
	D/A data register 1	DADR1	R/W	H'00	H'FFA5
	D/A control register	DACR01	R/W	H'1F	H'FFA6
Common	Module stop control register	MSTPCR	R/W	H'3FFF	H'FF3C

Note: * Lower 16 bits of the address.

15.2 Register Descriptions

15.2.1 D/A Data Registers 0, 1 (DADR0, DADR1)

Bit	:	7	6	5	4	3	2	1	0
Initial value :		0	0	0	0	0	0	0	0
R/W	:	R/W	R/W	R/W	R/W	R/W	R/W	R/W	R/W

DADR0, DADR1 are 8-bit readable/writable registers that store data for conversion.

Whenever output is enabled, the values in DADR0 and DADR1 are converted and output from the analog output pins.

DADR0 and DADR1 are each initialized to H'00 by a reset and in hardware standby mode.

15.2.2 D/A Control Registers 01 (DACR01)

Bit	:	7	6	5	4	3	2	1	0
		DAOE1	DAOE0	DAE	—	—	—	—	—
Initial value :		0	0	0	1	1	1	1	1
R/W	:	R/W	R/W	R/W	—	—	—	—	—

DACR01 is 8-bit readable/writable register that controls the operation of the D/A converter.

DACR01 is initialized to H'1F by a reset and in hardware standby mode.

Bit 7—D/A Output Enable 1 (DAOE1): Controls D/A conversion and analog output.

Bit 7

DAOE1	Description
0	Analog output DA1 is disabled (Initial value)
1	Channel 1 D/A conversion is enabled; analog output DA1 is enabled

Bit 6—D/A Output Enable 0 (DAOE0): Controls D/A conversion and analog output.

Bit 6

DAOE0	Description
0	Analog output DA0 is disabled (Initial value)
1	Channel 0 D/A conversion is enabled; analog output DA0 is enabled

Bit 5—D/A Enable (DAE): Used together with the DAOE0 and DAOE1 bits to control D/A conversion. When the DAE bit is cleared to 0, channel 0 and 1 D/A conversions are controlled independently. When the DAE bit is set to 1, channel 0 and 1 D/A conversions are controlled together.

Output of conversion results is always controlled independently by the DAOE0 and DAOE1 bits.

Bit 7 DAOE1	Bit 6 DAOE0	Bit 5 DAE	Description
0	0	×	Channel 0 and 1 D/A conversions disabled
		1	Channel 0 D/A conversion enabled Channel 1 D/A conversion disabled
		1	Channel 0 and 1 D/A conversions enabled
1	0	0	Channel 0 D/A conversion disabled Channel 1 D/A conversion enabled
		1	Channel 0 and 1 D/A conversions enabled
		×	Channel 0 and 1 D/A conversions enabled

×: Don't care

If the chip enters software standby mode when D/A conversion is enabled, the D/A output is held and the analog power current is the same as during D/A conversion. When it is necessary to reduce the analog power current in software standby mode, clear both the DAOE0 and DAOE1 bits to 0 to disable D/A output.

Bits 4 to 0—Reserved: These bits cannot be modified and are always read as 1.

15.2.3 Module Stop Control Register (MSTPCR)

		MSTPCRH								MSTPCRL							
Bit	:	15	14	13	12	11	10	9	8	7	6	5	4	3	2	1	0
Initial value	:	0	0	1	1	1	1	1	1	1	1	1	1	1	1	1	1
R/W	:	R/W	R/W	R/W	R/W	R/W	R/W	R/W	R/W	R/W	R/W	R/W	R/W	R/W	R/W	R/W	R/W

MSTPCR is a 16-bit readable/writable register that performs module stop mode control.

When the MSTP10 bit in MSTPCR is set to 1, D/A converter operation stops at the end of the bus cycle and a transition is made to module stop mode. Registers cannot be read or written to in module stop mode. For details, see section 19.5, Module Stop Mode.

MSTPCR is initialized to H'3FFF by a reset and in hardware standby mode. It is not initialized in software standby mode.

Bit 10—Module Stop (MSTP10): Specifies the D/A converter (channels 0, 1) module stop mode.

Bit 10

MSTP10	Description
0	D/A converter (channels 0, 1) module stop mode cleared
1	D/A converter (channels 0, 1) module stop mode set (Initial value)

15.3 Operation

The D/A converter includes D/A conversion circuits for two channels, each of which can operate independently.

D/A conversion is performed continuously while enabled by DACR. If either DADR0 or DADR1 is written to, the new data is immediately converted. The conversion result is output by setting the corresponding DAOE0 or DAOE1 bit to 1.

The operation example described in this section concerns D/A conversion on channel 0. Figure 15.2 shows the timing of this operation.

- [1] Write the conversion data to DADR0.
- [2] Set the DAOE0 bit in DACR01 to 1. D/A conversion is started and the DA0 pin becomes an output pin. The conversion result is output after the conversion time has elapsed. The output value is expressed by the following formula:

$$\frac{\text{DADR contents}}{256} \times V_{\text{ref}}$$

The conversion results are output continuously until DADR0 is written to again or the DAOE0 bit is cleared to 0.

- [3] If DADR0 is written to again, the new data is immediately converted. The new conversion result is output after the conversion time has elapsed.
- [4] If the DAOE0 bit is cleared to 0, the DA0 pin becomes an input pin.

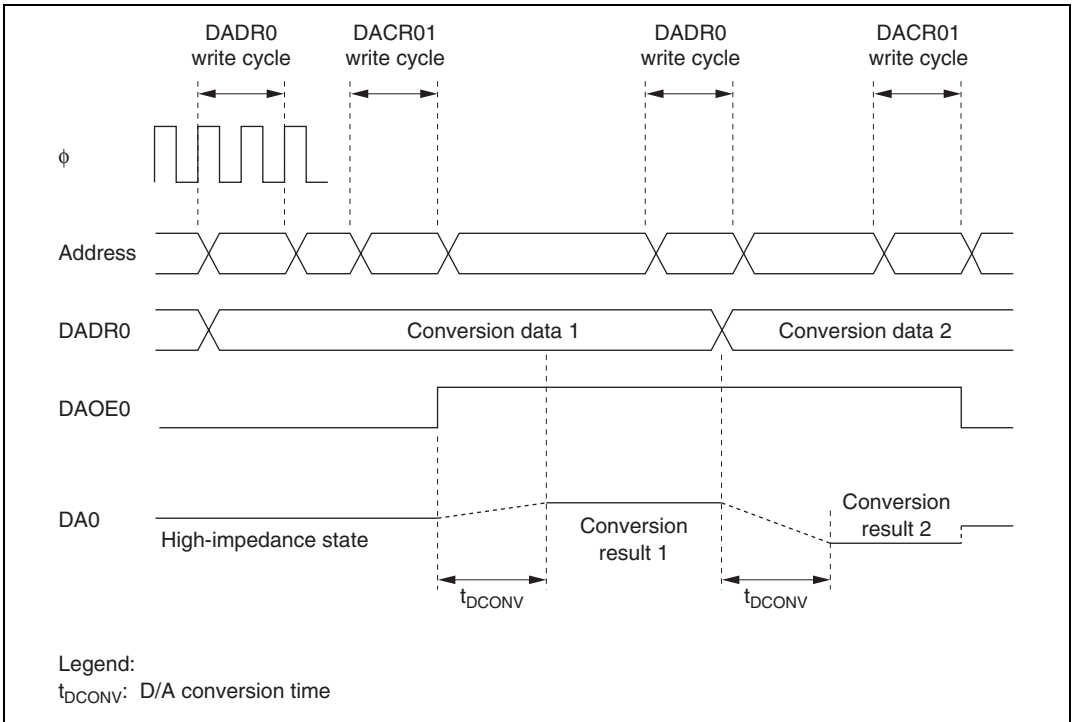

Figure 15.2 Example of D/A Converter Operation

Section 16 RAM

16.1 Overview

The chip has on-chip high-speed static RAM. The RAM is connected to the CPU by a 16-bit data bus, enabling one-state access by the CPU to both byte data and word data. This makes it possible to perform fast word data transfer.

The on-chip RAM can be enabled or disabled by means of the RAM enable bit (RAME) in the system control register (SYSCR).

Note: The amount of on-chip RAM is 16 kbytes in the H8S/2319C, 8 kbytes in the H8S/2319, H8S/2318, H8S/2317, H8S/2317S, H8S/2316S, H8S/2315, and H8S/2312S, 4 kbytes in the H8S/2314.

16.1.1 Block Diagram

Figure 16.1 shows a block diagram of 8 kbytes of on-chip RAM.

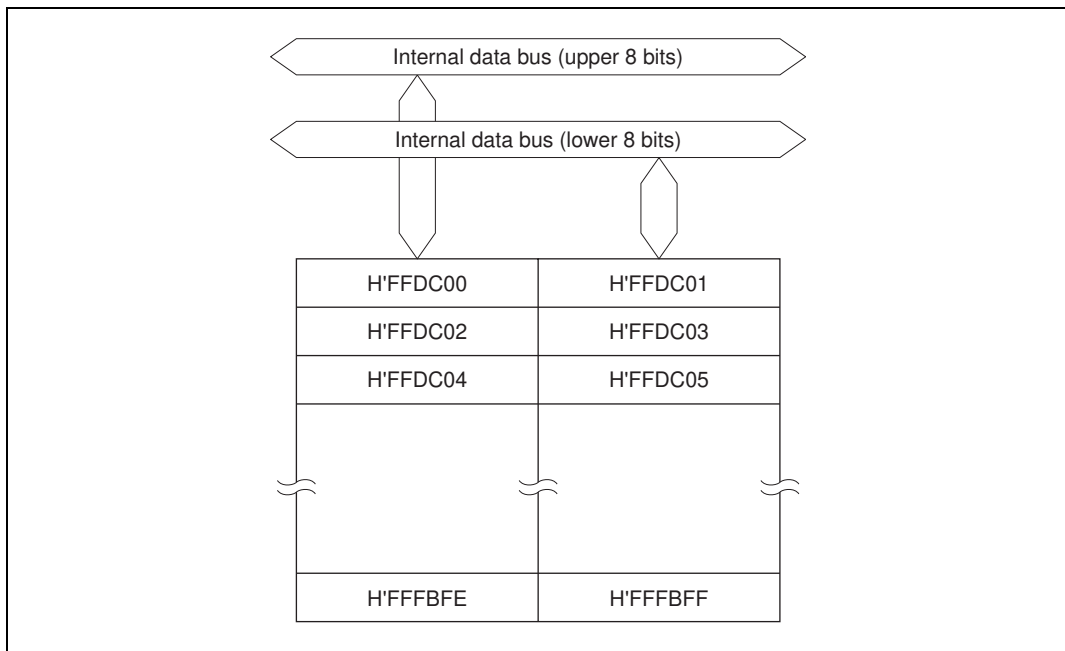

Figure 16.1 Block Diagram of RAM (8 kbytes)

16.1.2 Register Configuration

The on-chip RAM is controlled by SYSCR. Table 16.1 shows the address and initial value of SYSCR.

Table 16.1 RAM Register

Name	Abbreviation	R/W	Initial Value	Address*
System control register	SYSCR	R/W	H'01	H'FF39

Note: * Lower 16 bits of the address.

16.2 Register Descriptions

16.2.1 System Control Register (SYSCR)

Bit	:	7	6	5	4	3	2	1	0
		—	—	INTM1	INTM0	NMIEG	LWROD	—	RAME
Initial value :		0	0	0	0	0	0	0	1
R/W	:	R/W	—	R/W	R/W	R/W	R/W	R/W	R/W

The on-chip RAM is enabled or disabled by the RAME bit in SYSCR. For details of other bits in SYSCR, see section 5.2.1, System Control Register (SYSCR).

Bit 0—RAM Enable (RAME): Enables or disables the on-chip RAM. The RAME bit is initialized when the reset state is released. It is not initialized in software standby mode.

Bit 0 RAME	Description
0	On-chip RAM is disabled
1	On-chip RAM is enabled (Initial value)

16.3 Operation

When the RAME bit is set to 1, accesses to addresses H'FFDC00 to H'FFFBFF* are directed to the on-chip RAM. When the RAME bit is cleared to 0, the off-chip address space is accessed.

Since the on-chip RAM is connected to the CPU by an internal 16-bit data bus, it can be written to and read in byte or word units. Each type of access can be performed in one state.

Even addresses use the upper 8 bits, and odd addresses use the lower 8 bits. Word data must start at an even address.

Note: * The amount of on-chip RAM is 16 kbytes in the H8S/2319C, 8 kbytes in the H8S/2319, H8S/2318, H8S/2317, H8S/2317S, H8S/2316S, H8S/2315, and H8S/2312S, 4 kbytes in the H8S/2314.

16.4 Usage Note

DTC register information can be located in addresses H'FFF800 to H'FFFBFF. When the DTC is used, the RAME bit must not be cleared to 0.

Section 17 ROM

17.1 Overview

This LSI has 512, 384, 256, or 128 kbytes of on-chip flash memory, or 512, 384, 256, 128, or 64 kbytes of on-chip mask ROM. The ROM is connected to the bus master via a 16-bit data bus, enabling both byte and word data to be accessed in one state. Instruction fetching is thus speeded up, and processing speed increased.

The on-chip ROM is enabled and disabled by means of the mode pins (MD2 to MD0) and the EAE bit in BCRL.

The flash memory version of the chip can be erased and programmed with a PROM programmer, as well as on-board.

17.1.1 Block Diagram

Figure 17.1 shows a block diagram of 512 kbytes of on-chip ROM.

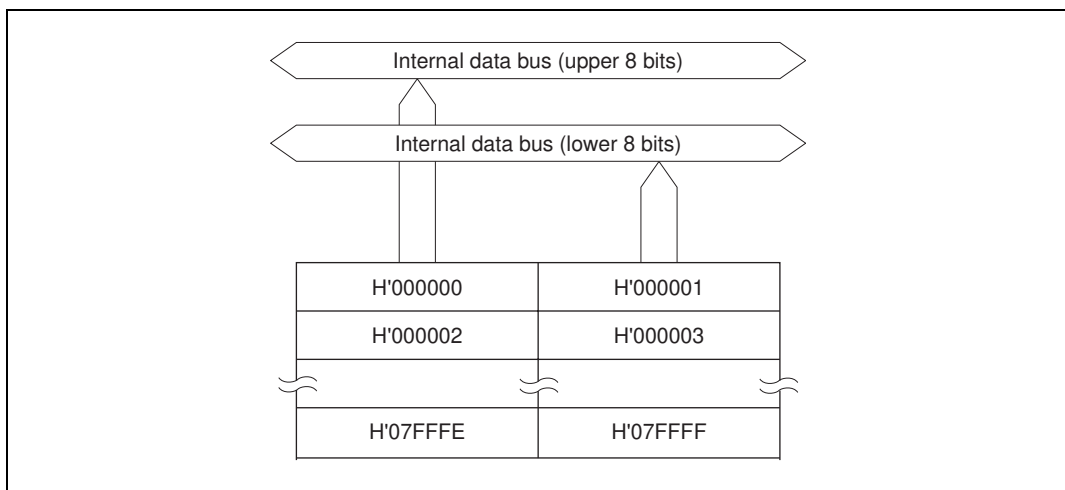

Figure 17.1 Block Diagram of ROM (512 kbytes)

17.1.2 Register Configuration

The operating mode of the chip is controlled by the mode pins and the BCRL register. The ROM-related registers are shown in table 17.1.

Table 17.1 ROM Registers

Register Name	Abbreviation	R/W	Initial Value	Address*
Mode control register	MDCR	R/W	Undefined	H'FF3B
Bus controller register	BCRL	R/W	Undefined	H'FED5

Note: * Lower 16 bits of the address.

17.2 Register Descriptions

17.2.1 Mode Control Register (MDCR)

Bit	:	7	6	5	4	3	2	1	0
		—	—	—	—	—	MDS2	MDS1	MDS0
Initial value :		1	0	0	0	0	—*	—*	—*
R/W	:	—	—	—	—	—	R	R	R

Note: * Determined by pins MD2 to MD0.

MDCR is an 8-bit read-only register used to monitor the current operating mode of the chip.

Bit 7—Reserved: This bit cannot be modified and is always read as 1.

Bits 6 to 3—Reserved: These bits cannot be modified and are always read as 0.

Bits 2 to 0—Mode Select 2 to 0 (MDS2 to MDS0): These bits indicate the input levels at pins MD2 to MD0 (the current operating mode). Bits MDS2 to MDS0 correspond to pins MD2 to MD0. MDS2 to MDS0 are read-only bits, and cannot be modified. The mode pin (MD2 to MD0) input levels are latched into these bits when MDCR is read. These latches are canceled by a reset.

17.2.2 Bus Control Register L (BCRL)

Bit	:	7	6	5	4	3	2	1	0
		BRLE	BREQOE	EAE	—	—	—	—	WAITE
Initial value	:	0	0	1	1	1	1	0	0
R/W	:	R/W	R/W	R/W	R/W	R/W	R/W	R/W	R/W

Enabling or disabling of part of the on-chip ROM area in the chip can be selected by means of the EAE bit in BCRL. For details of the other bits in BCRL, see section 6.2.5, Bus Control Register L (BCRL).

Bit 5—External Address Enable (EAE): Selects whether addresses H'010000 to H'03FFFF*² are to be internal addresses or external addresses.

		Description	
Bit 5 EAE	H8S/2319, H8S/2319C, H8S/2318, H8S/2315, H8S/2314	H8S/2317(S)*³	H8S/2316S
	0	On-chip ROM	Addresses H'010000 to H'01FFFF are in on-chip ROM and addresses H'020000 to H'03FFFF are a reserved area* ¹
1	Addresses H'010000 to H'03FFFF* ² are external addresses (in external expanded mode) or a reserved area* ¹ (in single-chip mode)		(Initial value)

- Notes:
- The reserved area must not be accessed.
 - H'010000 to H'03FFFF in the H8S/2318.
H'010000 to H'05FFFF in the H8S/2315 and H8S/2314.
H'010000 to H'07FFFF in the H8S/2319 and H8S/2319C.
 - H8S/2317S in mask ROM version.

17.3 Operation

The on-chip ROM is connected to the CPU by a 16-bit data bus, and both byte and word data can be accessed in one state. Even addresses are connected to the upper 8 bits, and odd addresses to the lower 8 bits. Word data must start at an even address.

The on-chip ROM is enabled and disabled by setting the mode pins (MD2 to MD0) and the EAE bit in BCRL. These settings are shown in table 17.2 and table 17.3.

Table 17.2 Operating Modes and ROM (H8S/2318 F-ZTAT, H8S/2317 F-ZTAT, H8S/2315 F-ZTAT, H8S/2314 F-ZTAT)

Mode	Operating Mode	Mode Pins				BCRL	
		FWE	MD2	MD1	MD0	EAE	On-Chip ROM
1	—	0	0	0	1	—	—
2				1	0		
3					1		
4	Advanced expanded mode with on-chip ROM disabled		1	0	0	—	Disabled
5	Advanced expanded mode with on-chip ROM disabled				1		
6	Advanced expanded mode with on-chip ROM enabled			1	0	0	Enabled (256 kbytes) ^{*1 *5}
						1	Enabled (64 kbytes)
7	Advanced single-chip mode				1	0	Enabled (256 kbytes) ^{*1 *5}
						1	Enabled (64 kbytes)
8	—	1	0	0	0	—	—
9					1		
10	Boot mode (advanced expanded mode with on-chip ROM enabled) ^{*3}			1	0	0	Enabled (256 kbytes) ^{*2 *5}
						1	Enabled (64 kbytes)
11	Boot mode (advanced single-chip mode) ^{*4}				1	0	Enabled (256 kbytes) ^{*2 *5}
						1	Enabled (64 kbytes)
12	—		1	0	0	—	—
13					1		
14	User program mode (advanced expanded mode with on-chip ROM enabled) ^{*3}			1	0	0	Enabled (256 kbytes) ^{*1 *5}
						1	Enabled (64 kbytes)
15	User program mode (advanced single-chip mode) ^{*4}				1	0	Enabled (256 kbytes) ^{*1 *5}
						1	Enabled (64 kbytes)

-
- Notes:
1. Note that in modes 6, 7, 14, and 15, the on-chip ROM that can be used after a reset is the 64-kbyte area from H'000000 to H'00FFFF.
 2. Note that in the mode 10 and mode 11 boot modes, the on-chip ROM that can be used immediately after all flash memory is erased by the boot program is the 64-kbyte area from H'000000 to H'00FFFF.
 3. Apart from the fact that flash memory can be erased and programmed, operation is the same as in advanced expanded mode with on-chip ROM enabled.
 4. Apart from the fact that flash memory can be erased and programmed, operation is the same as in advanced single-chip mode.
 5. The capacity of on-chip ROM in the H8S/2318 F-ZTAT is 256 kbytes.
The capacity of on-chip ROM in the H8S/2317 F-ZTAT is 128 kbytes.
The capacity of on-chip ROM in the H8S/2315 F-ZTAT and H8S/2314 F-ZTAT is 384 kbytes.

Table 17.3 Operating Modes and ROM (H8S/2319 F-ZTAT, H8S/2319C F-ZTAT, and Mask ROM Version)

Mode	Operating Mode	Mode Pins			BCRL	
		MD2	MD1	MD0	EAE	On-Chip ROM
1 ^{*3}	—	0	0	1	—	—
2 ^{*2}			1	0		
3 ^{*2}				1		
4	Advanced expanded mode with on-chip ROM disabled	1	0	0	—	Disabled
5	Advanced expanded mode with on-chip ROM disabled			1		
6	Advanced expanded mode with on-chip ROM enabled		1	0	0	Enabled (256 kbytes) ^{*1}
					1	Enabled (64 kbytes)
7	Advanced single-chip mode			1	0	Enabled (256 kbytes) ^{*1}
					1	Enabled (64 kbytes)

Notes: 1. Note that in modes 6 and 7, the on-chip ROM that can be used after a reset is the 64-kbyte area from H'000000 to H'00FFFF.

The H8S/2319 and H8S/2319C have 512 kbytes of on-chip ROM.

The H8S/2318 has 256 kbytes of on-chip ROM.

The H8S/2317 and H8S/2317S have 128 kbytes of on-chip ROM.

The H8S/2316S has 64 kbytes of on-chip ROM.

2. Boot mode in the H8S/2319 F-ZTAT and H8S/2319C F-ZTAT.

For boot mode in the H8S/2319 F-ZTAT, see table 17.30. Also see table 17.30, for information on user program mode.

For boot mode in the H8S/2319C F-ZTAT, see table 17.52. Also see table 17.52, for information on user program mode.

3. User boot mode in the H8S/2319C F-ZTAT. For user boot mode in the H8S/2319C F-ZTAT, see table 17.52.

17.4 Overview of Flash Memory (H8S/2318 F-ZTAT, H8S/2317 F-ZTAT, H8S/2315 F-ZTAT, H8S/2314 F-ZTAT)

17.4.1 Features

The H8S/2318 F-ZTAT, H8S/2317 F-ZTAT, H8S/2315 F-ZTAT, and H8S/2314 F-ZTAT have 384, 256, 128 kbytes of on-chip flash memory. The features of the flash memory are summarized below.

- Four flash memory operating modes
 - Program mode
 - Erase mode
 - Program-verify mode
 - Erase-verify mode
- Programming/erase methods

The flash memory is programmed 128 bytes at a time. Erasing is performed by block erase (in single-block units). To erase the entire flash memory, the individual blocks must be erased sequentially. Block erasing can be performed as required on 4-kbyte, 32-kbyte, and 64-kbyte blocks.
- Programming/erase times

The flash memory programming time is 10.0 ms (typ.) for simultaneous 128-byte programming, equivalent to 78 μ s (typ.) per byte, and the erase time is 50 ms (typ.).
- Reprogramming capability

The flash memory can be reprogrammed a minimum of 100 times.
- On-board programming modes

There are two modes in which flash memory can be programmed/erased/verified on-board:

 - Boot mode
 - User program mode
- Automatic bit rate adjustment

With data transfer in boot mode, the bit rate of the chip can be automatically adjusted to match the transfer bit rate of the host.
- Flash memory emulation by RAM*

Part of the RAM area can be overlapped onto flash memory, to emulate flash memory updates in real time.
- Protect modes

There are three protect modes, hardware, software, and error protect, which allow protected status to be designated for flash memory program/erase/verify operations.

- Programmer mode

Flash memory can be programmed/erased in programmer mode, using a PROM programmer, as well as in on-board programming mode.

Note: * Flash memory emulation by RAM is not supported in the H8S/2314 F-ZTAT.

17.4.2 Overview

Block Diagram

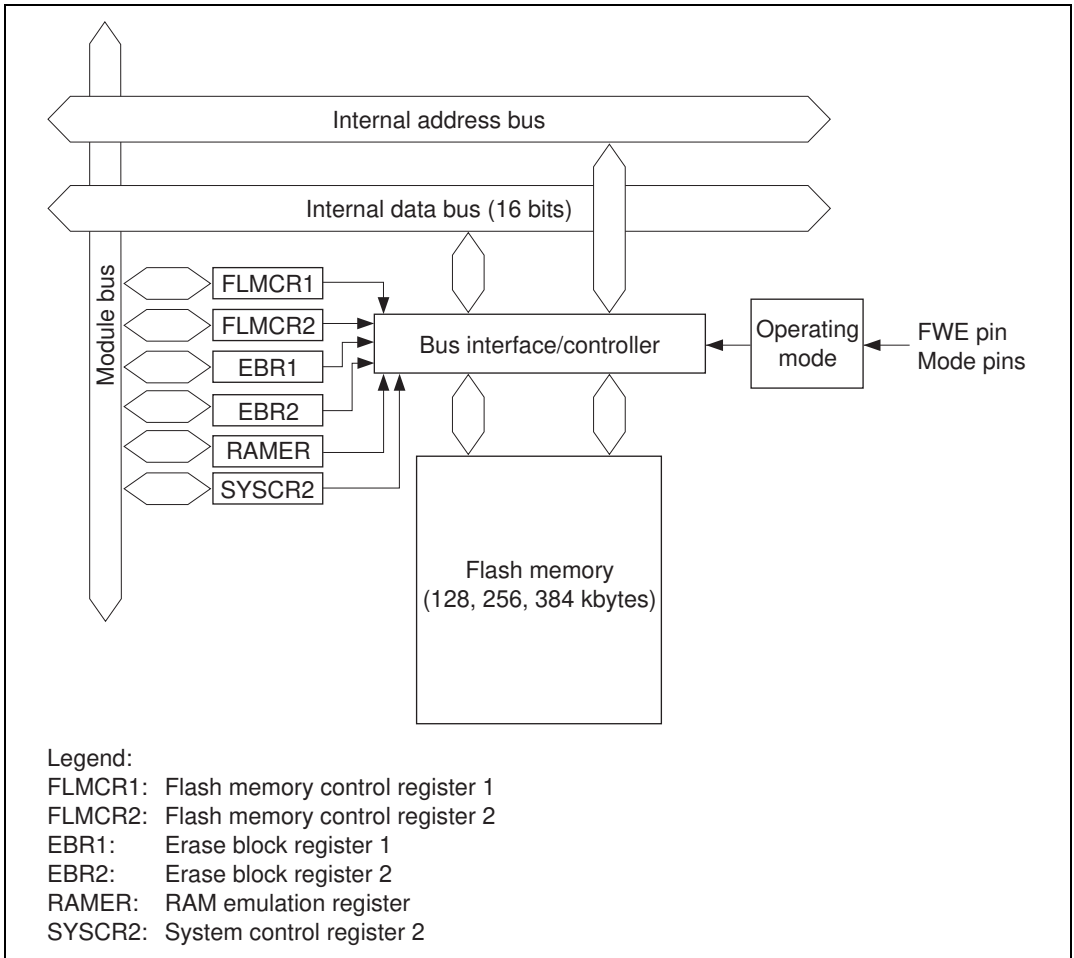

Figure 17.2 Block Diagram of Flash Memory

17.4.3 Flash Memory Operating Modes

Mode Transitions: When the mode pins and the FWE pin are set in the reset state and a reset-start is executed, the chip enters one of the operating modes shown in figure 17.3. In user mode, flash memory can be read but not programmed or erased.

Flash memory can be programmed and erased in boot mode, user program mode, and programmer mode.

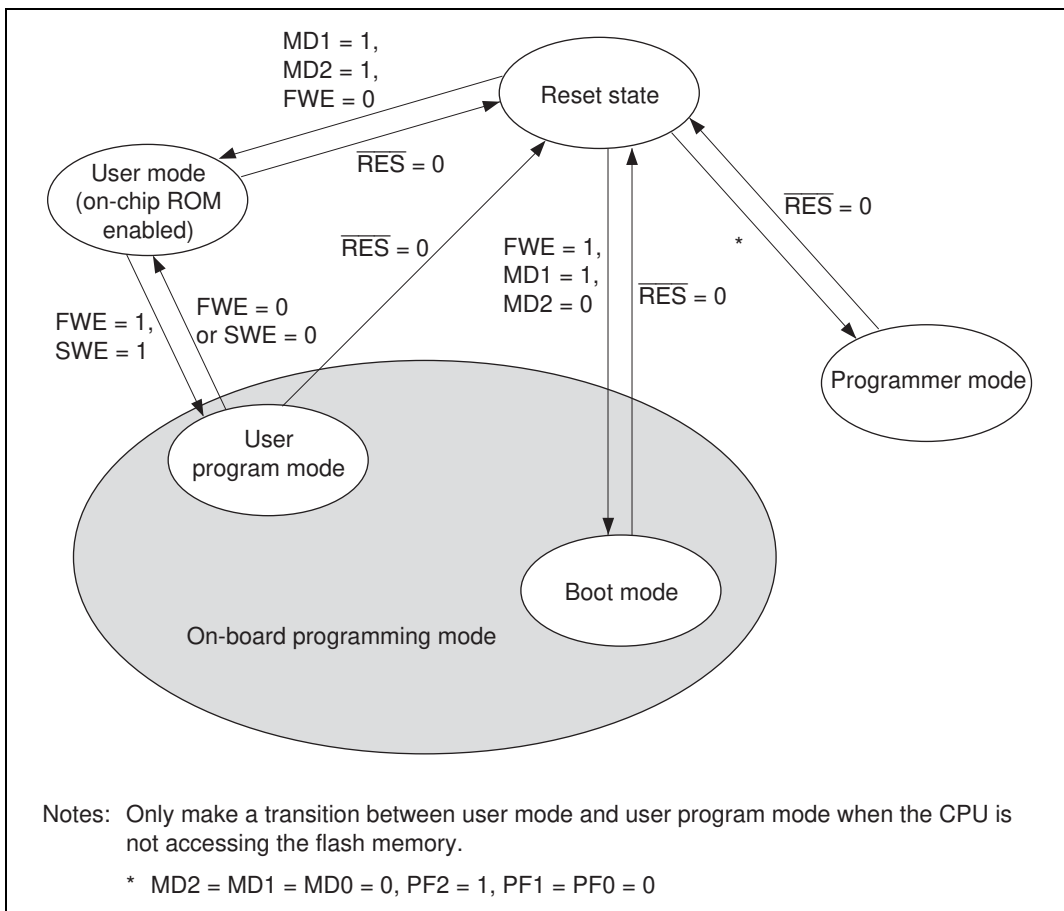

Figure 17.3 Flash Memory Mode Transitions

17.4.4 On-Board Programming Modes

• Boot mode

1. Initial state

The old program version or data remains written in the flash memory. The user should prepare the programming control program and new application program beforehand in the host.

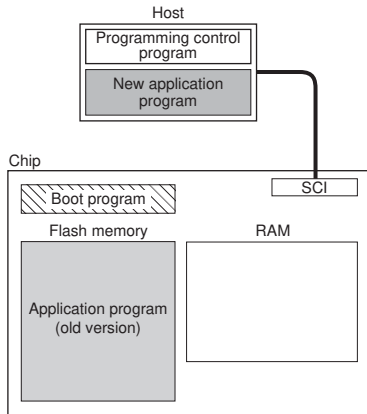

2. Programming control program transfer

When boot mode is entered, the boot program in the chip (originally incorporated in the chip) is started and the programming control program in the host is transferred to RAM via SCI communication. The boot program required for flash memory erasing is automatically transferred to the RAM boot program area.

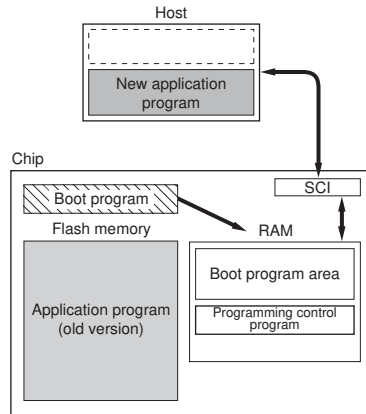

3. Flash memory initialization

The erase program in the boot program area (in RAM) is executed, and the flash memory is initialized (to H'FF'). In boot mode, entire flash memory erasure is performed, without regard to blocks.

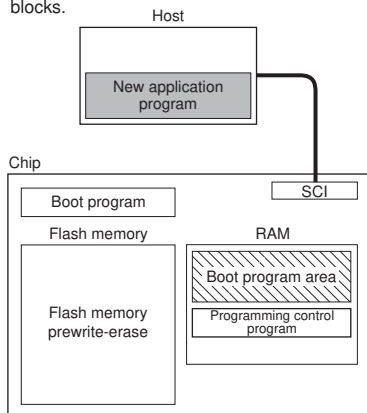

4. Writing new application program

The programming control program transferred from the host to RAM is executed, and the new application program in the host is written into the flash memory.

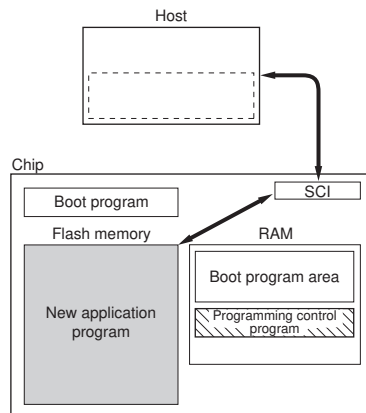

 Program execution state

Figure 17.4 Boot Mode

- User program mode

- Initial state

(1) The FWE assessment program that confirms that the FWE pin has been driven high, and (2) the program that will transfer the programming/erase control program to on-chip RAM should be written into the flash memory by the user beforehand. (3) The programming/erase control program should be prepared in the host or in the flash memory.

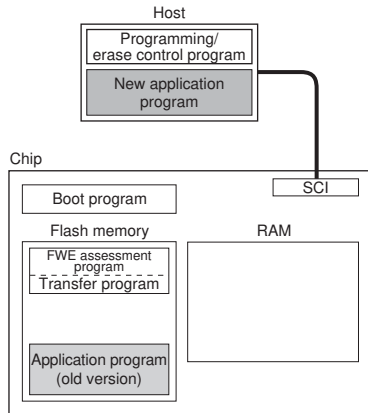

- Programming/erase control program transfer

When the FWE pin is driven high, user software confirms this fact, executes the transfer program in the flash memory, and transfers the programming/erase control program to RAM.

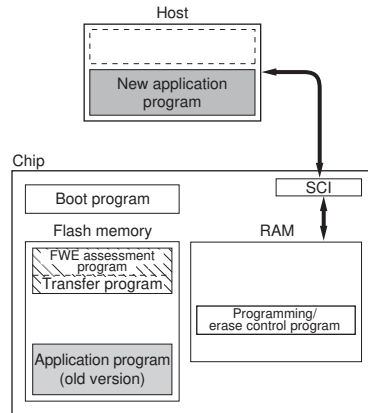

- Flash memory initialization

The programming/erase program in RAM is executed, and the flash memory is initialized (to H'FF). Erasing can be performed in block units, but not in byte units.

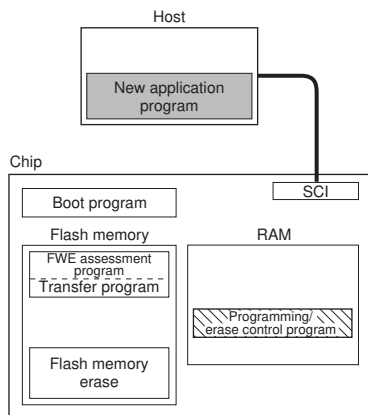

- Writing new application program

Next, the new application program in the host is written into the erased flash memory blocks. Do not write to unerased blocks.

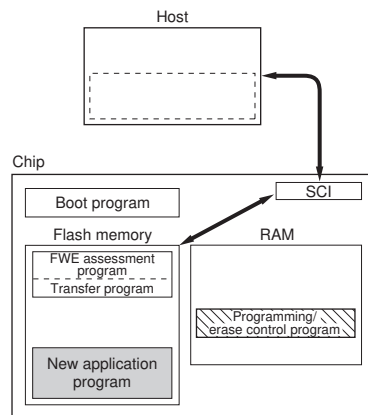

 Program execution state

Figure 17.5 User Program Mode (Example)

17.4.5 Flash Memory Emulation in RAM

Reading Overlap RAM Data in User Mode and User Program Mode: Emulation should be performed in user mode or user program mode. When the emulation block set in RAMER is accessed while the emulation function is being executed, data written in the overlap RAM is read.

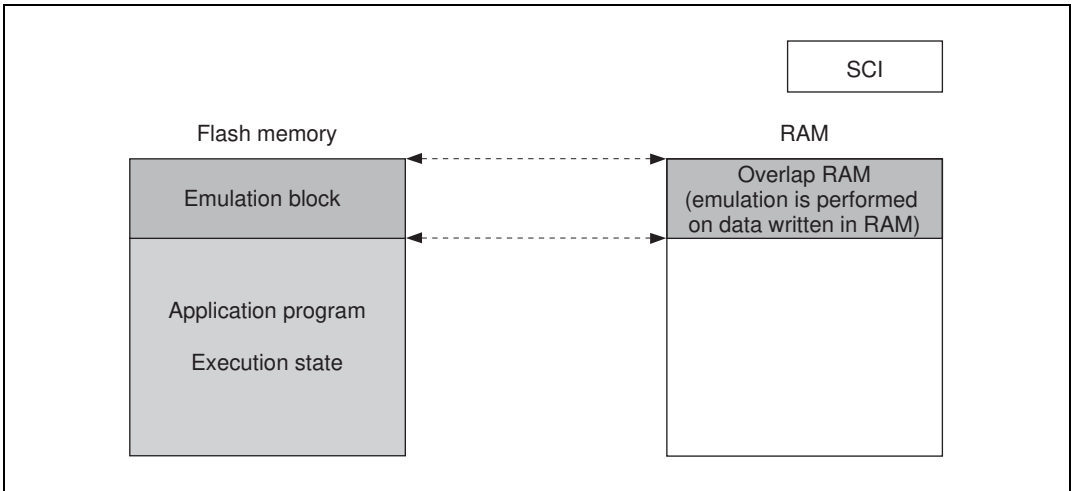

Figure 17.6 Reading Overlap RAM Data in User Mode and User Program Mode

Writing Overlap RAM Data in User Program Mode: When overlap RAM data is confirmed, the RAMS bit is cleared, RAM overlap is released, and writes should actually be performed to the flash memory.

When the programming control program is transferred to RAM, ensure that the transfer destination and the overlap RAM do not overlap, as this will cause data in the overlap RAM to be rewritten.

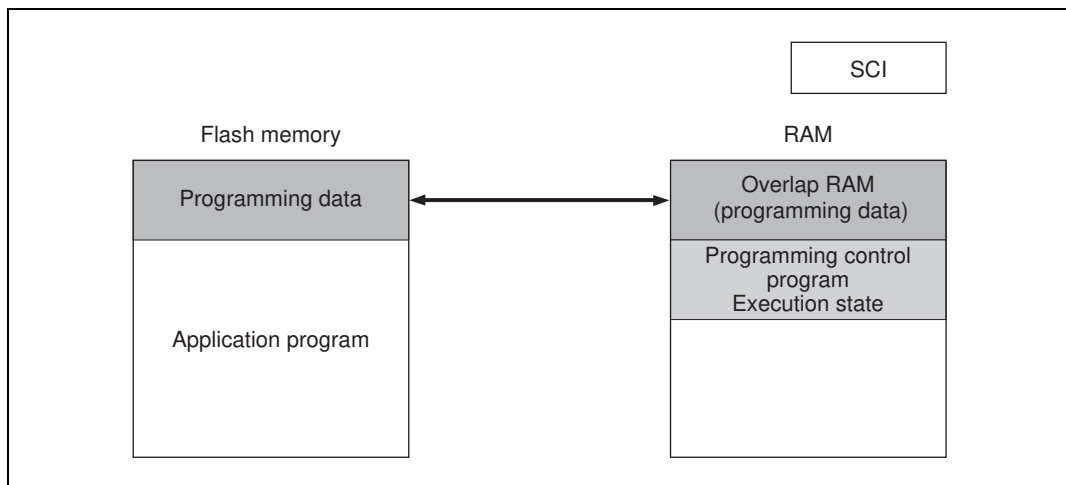

Figure 17.7 Writing Overlap RAM Data in User Program Mode

17.4.6 Differences between Boot Mode and User Program Mode

Table 17.4 Differences between Boot Mode and User Program Mode

	Boot Mode	User Program Mode
Entire memory erase	Yes	Yes
Block erase	No	Yes
Programming control program*	Program/program-verify	Erase/erase-verify/program/ program-verify/emulation

Note: * To be provided by the user, in accordance with the recommended algorithm.

17.4.7 Block Configuration

On-chip 128-kbyte flash memory is divided into one 64-kbyte block, one 32-kbyte block, and eight 4-kbyte blocks. On-chip 256-kbyte flash memory is divided into three 64-kbyte blocks, one 32-kbyte block, and eight 4-kbyte blocks. On-chip 384-kbyte flash memory is divided into five 64-kbyte blocks, one 32-kbyte block, and eight 4-kbyte blocks.

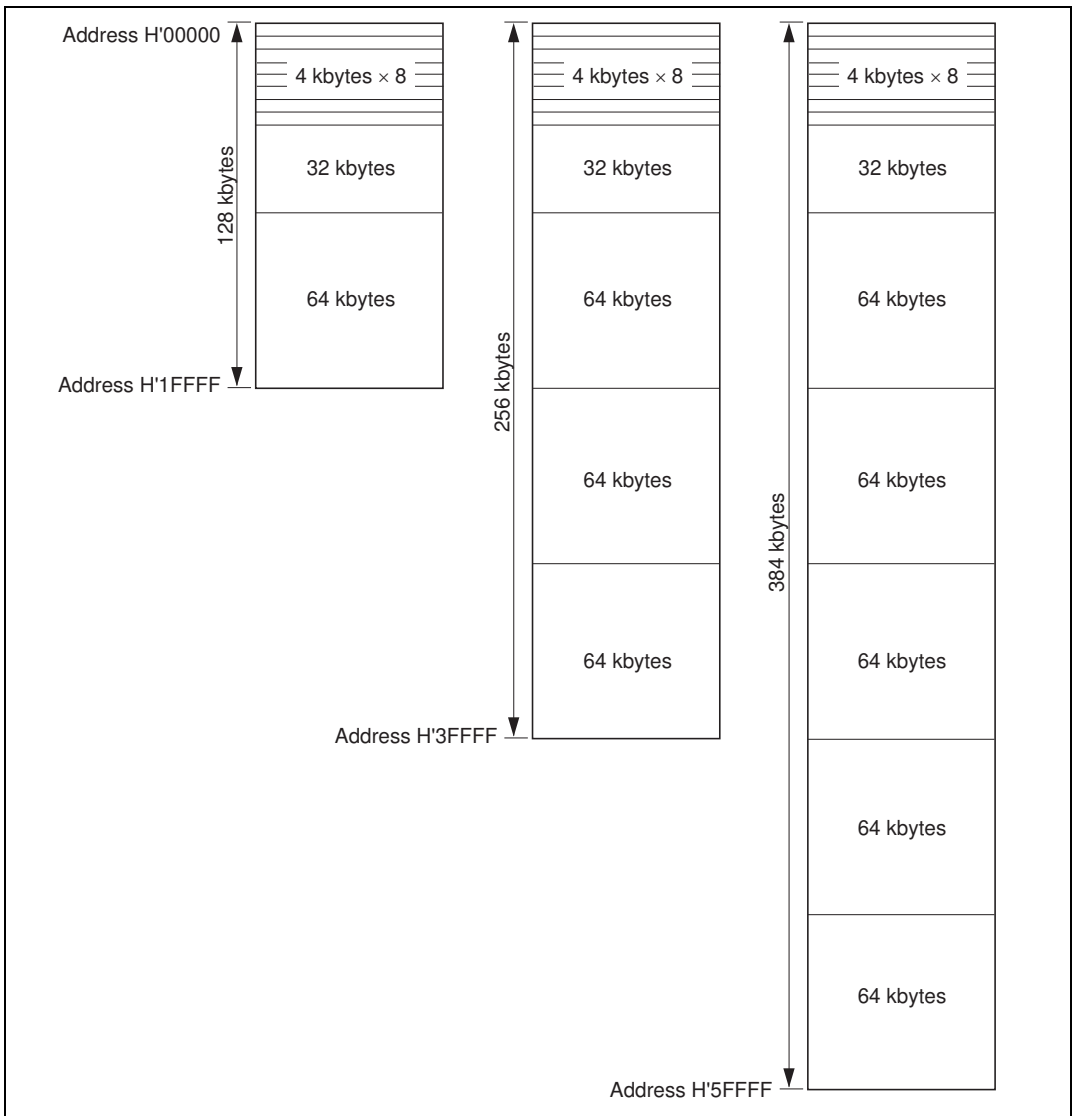

Figure 17.8 Flash Memory Block Configuration

17.4.8 Pin Configuration

The flash memory is controlled by means of the pins shown in table 17.5.

Table 17.5 Flash Memory Pins

Pin Name	Abbreviation	I/O	Function
Reset	RES	Input	Reset
Flash write enable	FWE	Input	Flash program/erase protection by hardware
Mode 2	MD2	Input	Sets MCU operating mode
Mode 1	MD1	Input	Sets MCU operating mode
Mode 0	MD0	Input	Sets MCU operating mode
Port F2	PF2	Input	Sets MCU operating mode in programmer mode
Port F1	PF1	Input	Sets MCU operating mode in programmer mode
Port F0	PF0	Input	Sets MCU operating mode in programmer mode
Transmit data	TxD1	Output	Serial transmit data output
Receive data	RxD1	Input	Serial receive data input

17.4.9 Register Configuration

The registers used to control the on-chip flash memory when enabled are shown in table 17.6. In order to access the FLMCR1, FLMCR2, EBR1, and EBR2 registers, the FLSHE bit must be set to 1 in SYSCR2 (except RAMER).

Table 17.6 Flash Memory Registers

Register Name	Abbreviation	R/W	Initial Value	Address ^{*1}
Flash memory control register 1	FLMCR1 ^{*6}	R/W ^{*3}	H'00 ^{*4}	H'FFC8 ^{*2}
Flash memory control register 2	FLMCR2 ^{*6}	R/W ^{*3}	H'00	H'FFC9 ^{*2}
Erase block register 1	EBR1 ^{*6}	R/W ^{*3}	H'00 ^{*5}	H'FFCA ^{*2}
Erase block register 2	EBR2 ^{*6}	R/W ^{*3}	H'00 ^{*5}	H'FFCB ^{*2}
System control register 2	SYSCR2 ^{*7}	R/W	H'00	H'FF42
RAM emulation register	RAMER	R/W	H'00	H'FEDB

Notes: 1. Lower 16 bits of the address.

2. Flash memory. Registers selection is performed by the FLSHE bit in system control register 2 (SYSCR2).
3. In modes in which the on-chip flash memory is disabled, a read will return H'00, and writes are invalid. Writes are also disabled when the FWE bit is cleared to 0 in FLMCR1.
4. When a high level is input to the FWE pin, the initial value is H'80.
5. When a low level is input to the FWE pin, or if a high level is input and the SWE bit in FLMCR1 is not set, these registers are initialized to H'00.
6. FLMCR1, FLMCR2, EBR1, and EBR2 are 8-bit registers. Only byte accesses are valid for these registers, the access requiring 2 states.
7. The SYSCR2 register can only be used in the F-ZTAT versions. In the mask ROM versions this register will return an undefined value if read, and cannot be modified.

17.5 Register Descriptions

17.5.1 Flash Memory Control Register 1 (FLMCR1)

Bit	:	7	6	5	4	3	2	1	0
		FWE	SWE	ESU	PSU	EV	PV	E	P
Initial value :		1/0	0	0	0	0	0	0	0
R/W	:	R	R/W	R/W	R/W	R/W	R/W	R/W	R/W

FLMCR1 is an 8-bit register used for flash memory operating mode control. Program-verify mode or erase-verify mode is entered by setting SWE to 1 when FWE = 1, then setting the EV or PV bit. Program mode is entered by setting SWE to 1 when FWE = 1, then setting the PSU bit, and finally setting the P bit. Erase mode is entered by setting SWE to 1 when FWE = 1, then setting the ESU bit, and finally setting the E bit. FLMCR1 is initialized by a reset, and in hardware standby mode and software standby mode. Its initial value is H'80 when a high level is input to the FWE pin, and H'00 when a low level is input. When on-chip flash memory is disabled, a read will return H'00, and writes are invalid.

Writes to the SWE bit in FLMCR1 are enabled only when FWE = 1; writes to bits ESU, PSU, EV, and PV only when FWE = 1 and SWE = 1; writes to the E bit only when FWE = 1, SWE = 1, and ESU = 1; and writes to the P bit only when FWE = 1, SWE = 1, and PSU = 1.

Bit 7—Flash Write Enable Bit (FWE): Sets hardware protection against flash memory programming/erasing.

Bit 7

FWE	Description
0	When a low level is input to the FWE pin (hardware-protected state)
1	When a high level is input to the FWE pin

Bit 6—Software Write Enable Bit (SWE): Enables or disables flash memory programming and erasing. This bit should be set when setting FLMCR1 bits 5 to 0, EBR1 bits 7 to 0, and EBR2 bits 3 to 0*.

When SWE = 1, the flash memory can only be read in program-verify or erase-verify mode.

Note: * EBR2 bits 5 to 0 should be set in the H8S/2315 F-ZTAT and H8S/2314 F-ZTAT.
Bits 1 and 0 should be set in the H8S/2317 F-ZTAT.

Bit 6

SWE	Description	
0	Writes disabled	(Initial value)
1	Writes enabled [Setting condition] When FWE = 1	

Bit 5—Erase Setup Bit (ESU): Prepares for a transition to erase mode. Do not set the SWE, PSU, EV, PV, E, or P bit at the same time.

Bit 5

ESU	Description	
0	Erase setup cleared	(Initial value)
1	Erase setup [Setting condition] When FWE = 1 and SWE = 1	

Bit 4—Program Setup Bit (PSU): Prepares for a transition to program mode. Do not set the SWE, ESU, EV, PV, E, or P bit at the same time.

Bit 4

PSU	Description	
0	Program setup cleared	(Initial value)
1	Program setup [Setting condition] When FWE = 1 and SWE = 1	

Bit 3—Erase-Verify (EV): Selects erase-verify mode transition or clearing. Do not set the SWE, ESU, PSU, PV, E, or P bit at the same time.

Bit 3

EV	Description	
0	Erase-verify mode cleared	(Initial value)
1	Transition to erase-verify mode [Setting condition] When FWE = 1 and SWE = 1	

Bit 2—Program-Verify (PV): Selects program-verify mode transition or clearing. Do not set the SWE, ESU, PSU, EV, E, or P bit at the same time.

Bit 2

PV	Description
0	Program-verify mode cleared (Initial value)
1	Transition to program-verify mode [Setting condition] When FWE = 1 and SWE = 1

Bit 1—Erase (E): Selects erase mode transition or clearing. Do not set the SWE, ESU, PSU, EV, PV, or P bit at the same time.

Bit 1

E	Description
0	Erase mode cleared (Initial value)
1	Transition to erase mode [Setting condition] When FWE = 1, SWE = 1, and ESU = 1

Bit 0—Program (P): Selects program mode transition or clearing. Do not set the SWE, PSU, ESU, EV, PV, or E bit at the same time.

Bit 0

P	Description
0	Program mode cleared (Initial value)
1	Transition to program mode [Setting condition] When FWE = 1, SWE = 1, and PSU = 1

17.5.2 Flash Memory Control Register 2 (FLMCR2)

Bit	:	7	6	5	4	3	2	1	0
		FLER	—	—	—	—	—	—	—
Initial value :		0	0	0	0	0	0	0	0
R/W	:	R	—	—	—	—	—	—	—

FLMCR2 is an 8-bit register that controls the flash memory operating modes. FLMCR2 is initialized to H'00 by a reset, and in hardware standby mode and software standby mode.

When on-chip flash memory is disabled, a read will return H'00 and writes are invalid.

Bit 7—Flash Memory Error (FLER): Indicates that an error has occurred during an operation on flash memory (programming or erasing). When FLER is set to 1, flash memory goes to the error-protection state.

Bit 7

FLER	Description
0	Flash memory is operating normally (Initial value) Flash memory program/erase protection (error protection) is disabled [Clearing condition] Reset or hardware standby mode
1	An error has occurred during flash memory programming/erasing Flash memory program/erase protection (error protection) is enabled [Setting condition] See section 17.8.3, Error Protection

Bits 6 to 0—Reserved: These bits cannot be modified and are always read as 0.

17.5.3 Erase Block Register 1 (EBR1)

Bit	:	7	6	5	4	3	2	1	0
EBR1		EB7	EB6	EB5	EB4	EB3	EB2	EB1	EB0
Initial value	:	0	0	0	0	0	0	0	0
R/W	:	R/W	R/W	R/W	R/W	R/W	R/W	R/W	R/W

EBR1 is an 8-bit register that specifies the flash memory erase area block by block. EBR1 is initialized to H'00 by a reset, in hardware standby mode and software standby mode, when a low level is input to the FWE pin, and when a high level is input to the FWE pin and the SWE bit in FLMCR1 is not set. When a bit in EBR1 is set, the corresponding block can be erased. Other blocks are erase-protected. Set only one bit in EBR1 and EBR2 together (setting more than one bit will automatically clear all EBR1 and EBR2 bits to 0). When on-chip flash memory is disabled, a read will return H'00 and writes are invalid.

The flash memory block configuration is shown in table 17.7.

17.5.4 Erase Block Register 2 (EBR2)

Bit	:	7	6	5	4	3	2	1	0
EBR2		—	—	EB13 ^{*1}	EB12 ^{*1}	EB11 ^{*2}	EB10 ^{*2}	EB9	EB8
Initial value	:	0	0	0	0	0	0	0	0
R/W	:	—	—	R/W ^{*1}	R/W ^{*1}	R/W	R/W	R/W	R/W

Notes: 1. Available only in the H8S/2315 F-ZTAT and H8S/2314 F-ZTAT.

2. Reserved in the H8S/2317 F-ZTAT. Only 0 should be written.

EBR2 is an 8-bit register that specifies the flash memory erase area block by block. EBR2 is initialized to H'00 by a reset, in hardware standby mode and software standby mode, when a low level is input to the FWE pin, and when a high level is input to the FWE pin and the SWE bit in FLMCR1 is not set. When a bit in EBR2 is set, the corresponding block can be erased. Other blocks are erase-protected. Set only one bit in EBR2 and EBR1 together (setting more than one bit will automatically clear all EBR1 and EBR2 bits to 0, bits 7 to 2 are reserved in the H8S/2317 F-ZTAT). Bits 7 to 4 are reserved (bits 7 and 6 are reserved in the H8S/2315 F-ZTAT and H8S/2314 F-ZTAT): they are always read as 0 and cannot be modified. When on-chip flash memory is disabled, a read will return H'00, and writes are invalid.

The flash memory block configuration is shown in table 17.7.

Table 17.7 Flash Memory Erase Blocks

Block (Size)	Address
EB0 (4 kbytes)	H'000000 to H'000FFF
EB1 (4 kbytes)	H'001000 to H'001FFF
EB2 (4 kbytes)	H'002000 to H'002FFF
EB3 (4 kbytes)	H'003000 to H'003FFF
EB4 (4 kbytes)	H'004000 to H'004FFF
EB5 (4 kbytes)	H'005000 to H'005FFF
EB6 (4 kbytes)	H'006000 to H'006FFF
EB7 (4 kbytes)	H'007000 to H'007FFF
EB8 (32 kbytes)	H'008000 to H'00FFFF
EB9 (64 kbytes)	H'010000 to H'01FFFF
EB10 (64 kbytes) ^{*2}	H'020000 to H'02FFFF
EB11 (64 kbytes) ^{*2}	H'030000 to H'03FFFF
EB12 (64 kbytes) ^{*1}	H'040000 to H'04FFFF
EB13 (64 kbytes) ^{*1}	H'050000 to H'05FFFF

Notes: 1. These blocks are valid only in the H8S/2315 F-ZTAT and H8S/2314 F-ZTAT.
 2. Not available in the H8S/2317 F-ZTAT.

17.5.5 System Control Register 2 (SYSCR2)

Bit	:	7	6	5	4	3	2	1	0
		—	—	—	—	FLSHE	—	—	—
Initial value	:	0	0	0	0	0	0	0	0
R/W	:	—	—	—	—	R/W	—	—	—

SYSCR2 is an 8-bit readable/writable register that performs on-chip flash memory control.

SYSCR2 is initialized to H'00 by a reset and in hardware standby mode.

SYSCR2 can only be used in the F-ZTAT versions. In the mask ROM versions this register will return an undefined value if read, and cannot be modified.

Bits 7 to 4—Reserved: These bits cannot be modified and are always read as 0.

Bit 3—Flash Memory Control Register Enable (FLSHE): Controls CPU access to the flash memory control registers (FLMCR1, FLMCR2, EBR1, and EBR2). Writing 1 to the FLSHE bit enables the flash memory control registers to be read and written to. Clearing FLSHE to 0 designates these registers as unselected (the register contents are retained).

Bit 3

FLSHE	Description
0	Flash control registers are not selected for addresses H'FFFFC8 to H'FFFFCB (Initial value)
1	Flash control registers are selected for addresses H'FFFFC8 to H'FFFFCB

Bits 2 to 0—Reserved: These bits cannot be modified and are always read as 0.

17.5.6 RAM Emulation Register (RAMER)

Bit	:	7	6	5	4	3	2	1	0
		—	—	—	—	RAMS	RAM2	RAM1	RAM0
Initial value :		0	0	0	0	0	0	0	0
R/W :		—	—	—	—	R/W	R/W	R/W	R/W

RAMER specifies the area of flash memory to be overlapped with part of RAM when emulating real-time flash memory programming. RAMER is initialized to H'00 by a reset and in hardware standby mode. It is not initialized in software standby mode. RAMER settings should be made in user mode or user program mode.

Flash memory area divisions are shown in table 17.8. To ensure correct operation of the emulation function, the ROM for which RAM emulation is performed should not be accessed immediately after this register has been modified. Normal execution of an access immediately after register modification is not guaranteed.

Note: RAM emulation function is not supported in the H8S/2314 F-ZTAT.

Bits 7 to 4—Reserved: These bits cannot be modified and are always read as 0.

Bit 3—RAM Select (RAMS): Specifies selection or non-selection of flash memory emulation in RAM. When RAMS = 1, all flash memory blocks are program/erase-protected.

Bit 3

RAMS	Description	
0	Emulation not selected Program/erase-protection of all flash memory blocks is disabled	(Initial value)
1	Emulation selected Program/erase-protection of all flash memory blocks is enabled	

Bits 2 to 0—Flash Memory Area Selection (RAM2 to RAM0): These bits are used together with bit 3 to select the flash memory area to be overlapped with RAM (see table 17.8).

Table 17.8 Flash Memory Area Divisions

RAM Area	Block Name	RAMS	RAM2	RAM1	RAM0
H'FFDC00 to H'FFEBFF	RAM area, 4 kbytes	0	×	×	×
H'000000 to H'000FFF	EB0 (4 kbytes)	1	0	0	0
H'001000 to H'001FFF	EB1 (4 kbytes)	1	0	0	1
H'002000 to H'002FFF	EB2 (4 kbytes)	1	0	1	0
H'003000 to H'003FFF	EB3 (4 kbytes)	1	0	1	1
H'004000 to H'004FFF	EB4 (4 kbytes)	1	1	0	0
H'005000 to H'005FFF	EB5 (4 kbytes)	1	1	0	1
H'006000 to H'006FFF	EB6 (4 kbytes)	1	1	1	0
H'007000 to H'007FFF	EB7 (4 kbytes)	1	1	1	1

×: Don't care

17.6 On-Board Programming Modes

When pins are set to on-board programming mode, program/erase/verify operations can be performed on the on-chip flash memory. There are two on-board programming modes: boot mode and user program mode. The pin settings for transition to each of these modes are shown in table 17.9. For a diagram of the transitions to the various flash memory modes, see figure 17.3.

Table 17.9 Setting On-Board Programming Modes

MCU Mode	Modes	Pins			
	CPU Operating Mode	FWE	MD2	MD1	MD0
Boot mode	Advanced expanded mode with on-chip ROM enabled	1	0	1	0
	Advanced single-chip mode				1
User program mode*	Advanced expanded mode with on-chip ROM enabled	1	1	1	0
	Advanced single-chip mode				1

Note: * Normally, user mode should be used. Set the FWE pin to 1 to make a transition to user program mode before performing a program/erase/verify operation.

17.6.1 Boot Mode

When boot mode is used, the flash memory programming control program must be prepared in the host beforehand. The channel 1 SCI to be used is set to asynchronous mode.

When a reset-start is executed after the H8S/2318 F-ZTAT, H8S/2317 F-ZTAT, H8S/2315 F-ZTAT, or H8S/2314 F-ZTAT chip's pins have been set to boot mode, the boot program built into the chip is started and the programming control program prepared in the host is serially transmitted to the chip via the SCI. In the chip, the programming control program received via the SCI is written into the programming control program area in on-chip RAM. After the transfer is completed, control branches to the start address of the programming control program area and the programming control program execution state is entered (flash memory programming is performed).

The transferred programming control program must therefore include coding that follows the programming algorithm given later.

The system configuration in boot mode is shown in figure 17.9, and the boot program mode execution procedure in figure 17.10.

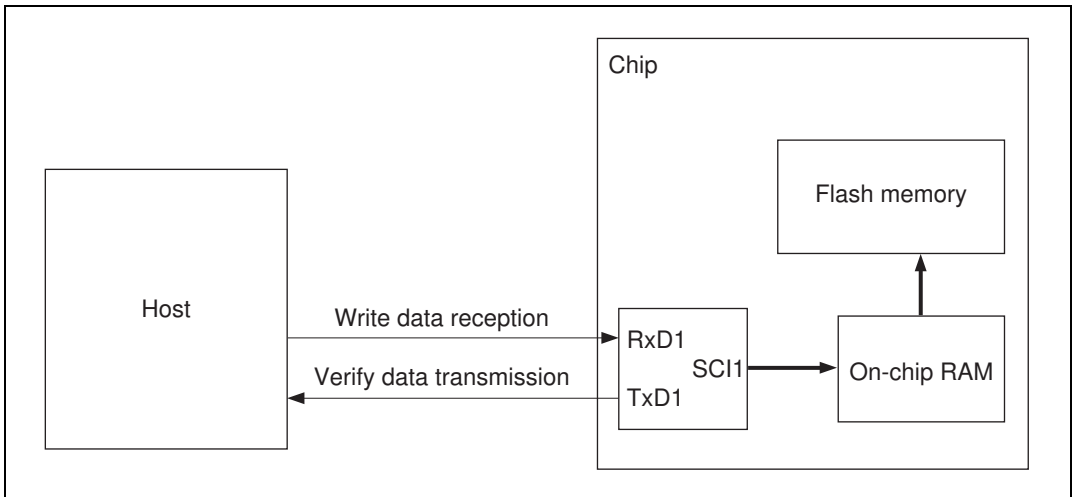

Figure 17.9 System Configuration in Boot Mode

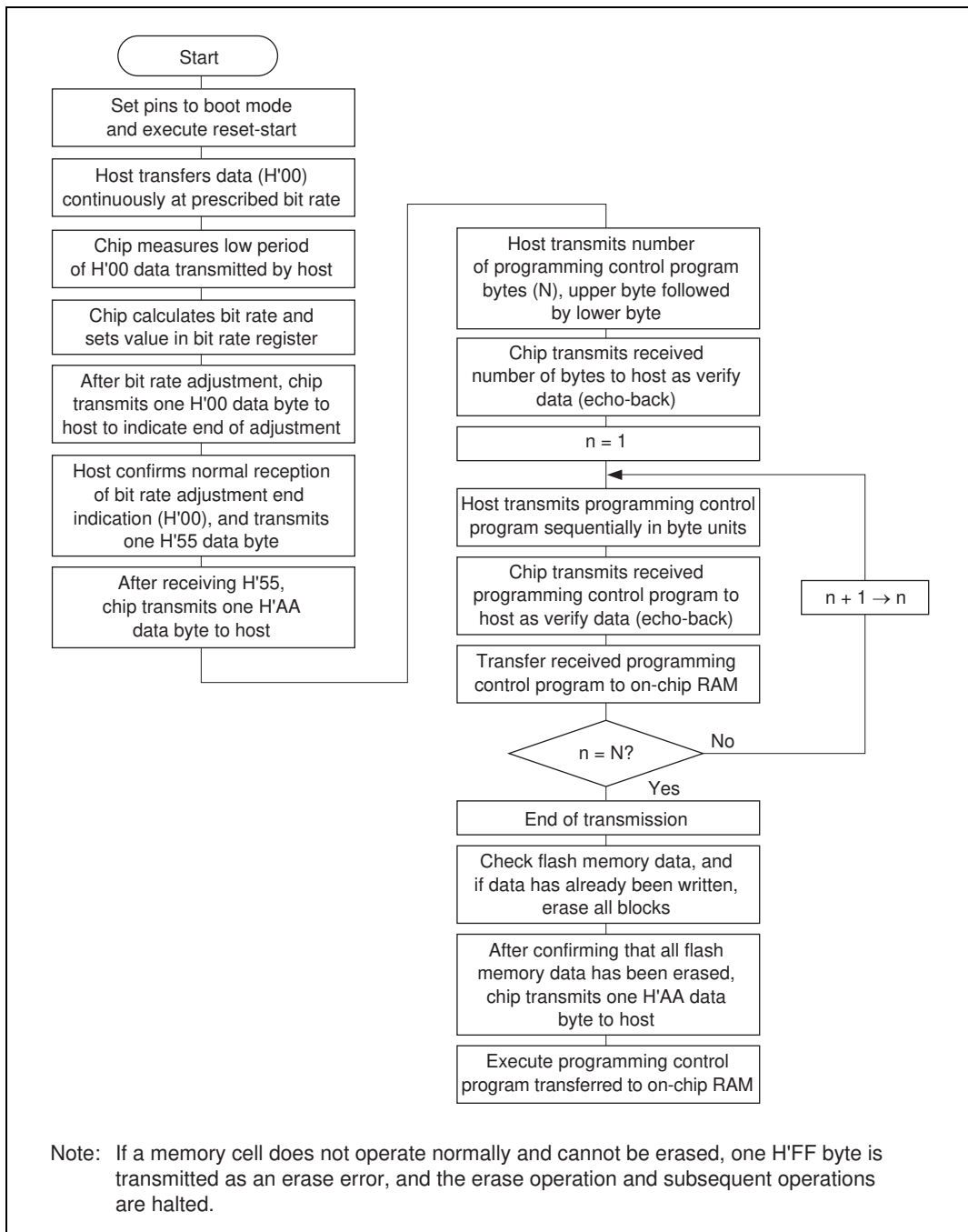

Figure 17.10 Boot Mode Execution Procedure

Automatic SCI Bit Rate Adjustment: When boot mode is initiated, the H8S/2318 F-ZTAT, H8S/2317 F-ZTAT, H8S/2315 F-ZTAT, or H8S/2314 F-ZTAT chip measures the low period of the asynchronous SCI communication data (H'00) transmitted continuously from the host. The SCI transmit/receive format should be set as follows: 8-bit data, 1 stop bit, no parity. The chip calculates the bit rate of the transmission from the host from the measured low period, and transmits one H'00 byte to the host to indicate the end of bit rate adjustment. The host should confirm that this adjustment end indication (H'00) has been received normally, and transmit one H'55 byte to the chip. If reception cannot be performed normally, initiate boot mode again (reset), and repeat the above operations. Depending on the host's transmission bit rate and the chip's system clock frequency, there will be a discrepancy between the bit rates of the host and the chip. To ensure correct SCI operation, the host's transfer bit rate should be set to 9,600 or 19,200 bps.

Table 17.10 shows typical host transfer bit rates and system clock frequencies for which automatic adjustment of the MCU's bit rate is possible. The boot program should be executed within this system clock range.

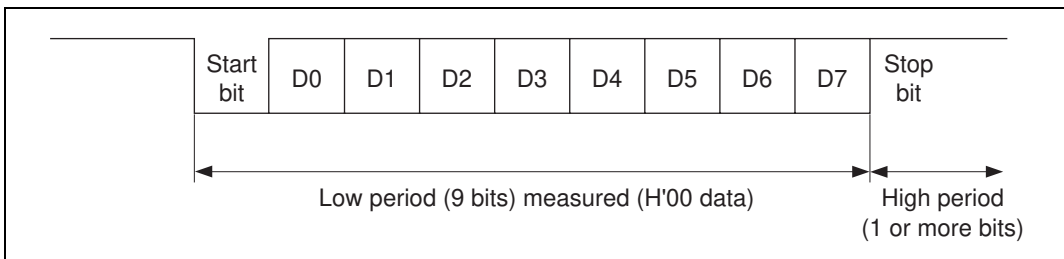

Figure 17.11 Automatic SCI Bit Rate Adjustment

Table 17.10 System Clock Frequencies for Which Automatic Adjustment of H8S/2318 F-ZTAT, H8S/2317 F-ZTAT, H8S/2315 F-ZTAT, or H8S/2314 F-ZTAT Bit Rate Is Possible

Host Bit Rate	System Clock Frequency for Which Automatic Adjustment of H8S/2318 F-ZTAT, H8S/2317 F-ZTAT, H8S/2315 F-ZTAT, or H8S/2314 F-ZTAT Bit Rate Is Possible
19,200 bps	16 to 25 MHz
9,600 bps	8 to 25 MHz

On-Chip RAM Area Divisions in Boot Mode: In boot mode, the 2-kbyte area from H'FFDC00 to H'FFE3FF is reserved for use by the boot program, as shown in figure 17.12. The area to which the programming control program is transferred is H'FFE400 to H'FFFBFF. The boot program area can be used when the programming control program transferred into RAM enters the execution state. A stack area should be set up as required.

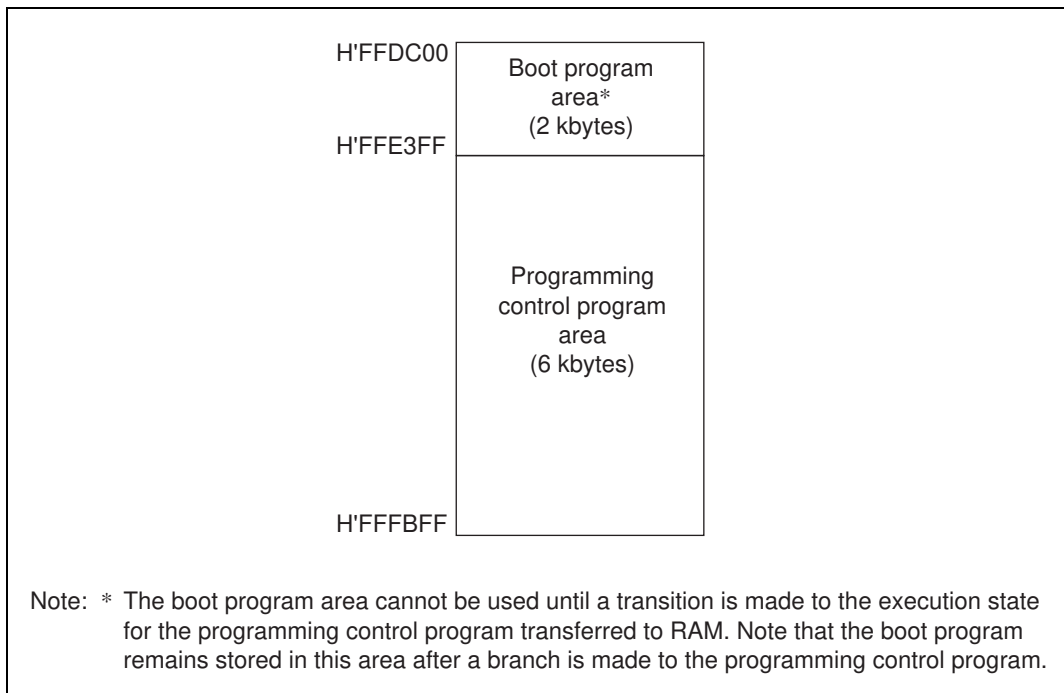

Figure 17.12 RAM Areas in Boot Mode

H8S/2314 F-ZTAT On-Chip RAM Area Divisions in Boot Mode: In boot mode, the 2-kbyte area from H'FFDC00 to H'FFE3FF is reserved for boot program use, as shown in figure 17.13. The area to which the programming control program is transferred is H'FFE400 to H'FFFBFF. The boot program area becomes available when a transition is made to the execution state for the programming control program transferred to RAM. A stack area should be set as required.

The 4-kbyte area from H'FFDC00 to H'FFE3FF is a reserved area used only in boot mode. It should not be used for any purpose other than flash memory programming/erasing.

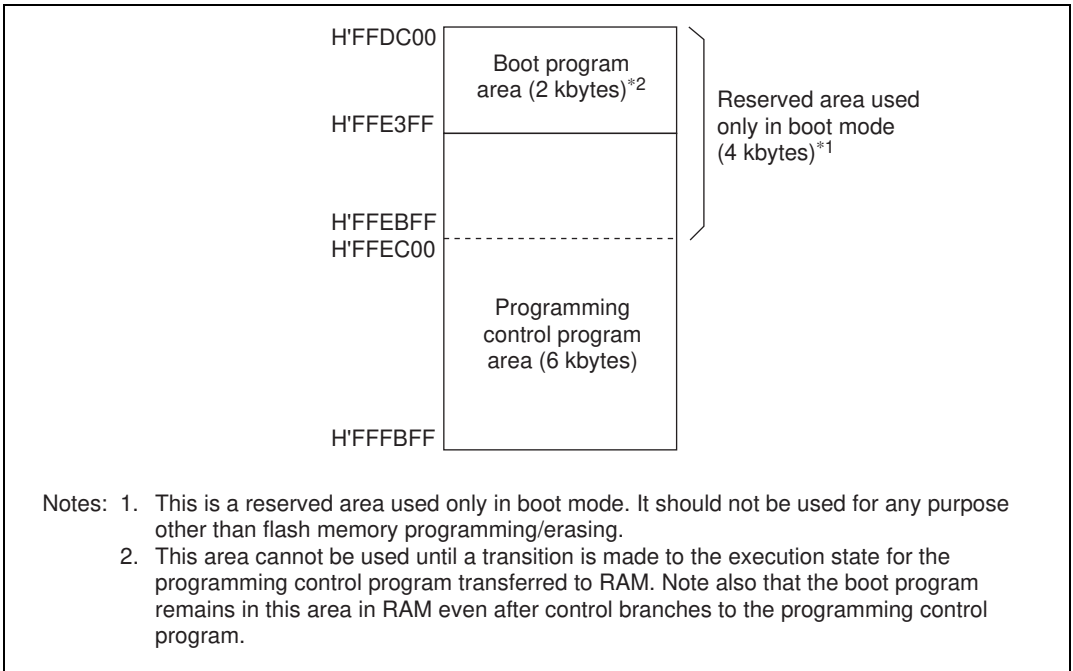

Figure 17.13 RAM Areas in Boot Mode

Notes on Use of Boot Mode

- When the chip comes out of reset in boot mode, it measures the low-level period of the input at the SCI's RxD1 pin. The reset should end with RxD1 high. After the reset ends, it takes approximately 100 states before the chip is ready to measure the low-level period of the RxD1 pin.
- In boot mode, if any data has been programmed into the flash memory (if all data is not 1), all flash memory blocks are erased. Boot mode is for use when user program mode is unavailable, such as the first time on-board programming is performed, or if the program activated in user program mode is accidentally erased.
- Interrupts cannot be used while the flash memory is being programmed or erased.
- The RxD1 and TxD1 pins should be pulled up on the board.
- Before branching to the programming control program (RAM area H'FFE400 to H'FFFBFF), the chip terminates transmit and receive operations by the on-chip SCI (channel 1) (by clearing the RE and TE bits in SCR to 0), but the adjusted bit rate value remains set in BRR. The transmit data output pin, TxD1, goes to the high-level output state (P31DDR = 1, P31DR = 1).

The contents of the CPU's internal general registers are undefined at this time, so these registers must be initialized immediately after branching to the programming control program. In particular, since the stack pointer (SP) is used implicitly in subroutine calls, etc., a stack area must be specified for use by the programming control program.

Initial settings must also be made for the other on-chip registers.

- Boot mode can be entered by making the pin settings shown in table 17.9 and executing a reset-start.

Boot mode can be cleared by driving the reset pin low, waiting at least 20 states, then setting the FWE pin and mode pins, and executing reset release^{*1}. Boot mode can also be cleared by a WDT overflow reset.

Do not change the mode pin input levels in boot mode, and do not drive the FWE pin low while the boot program is being executed or while flash memory is being programmed or erased^{*2}.

- If the mode pin input levels are changed (for example, from low to high) during a reset, the state of ports with multiplexed address functions and bus control output pins (AS, RD, HWR) will change according to the change in the microcomputer's operating mode^{*3}.

Therefore, care must be taken to make pin settings to prevent these pins from becoming output signal pins during a reset, or to prevent collision with signals outside the microcomputer.

- Notes:
1. Mode pins and FWE pin input must satisfy the mode programming setup time ($t_{MDS} = 200$ ns) with respect to the reset release timing, as shown in figures 17.30 to 17.32.
 2. For further information on FWE application and disconnection, see section 17.12, Flash Memory Programming and Erasing Precautions.
 3. See section 8, I/O Ports.

17.6.2 User Program Mode

When set to user program mode, the chip can program and erase its flash memory by executing a user program/erase control program. Therefore, on-board reprogramming of the on-chip flash memory can be carried out by providing on-board means of FWE control and supply of programming data, and storing a program/erase control program in part of the program area as necessary.

To select user program mode, select a mode that enables the on-chip flash memory (mode 6 or 7), and apply a high level to the FWE pin. In this mode, on-chip supporting modules other than flash memory operate as they normally would in modes 6 and 7.

The flash memory itself cannot be read while the SWE bit is set to 1 to perform programming or erasing, so the control program that performs programming and erasing should be run in on-chip RAM or external memory. When the program is located in external memory, an instruction for programming the flash memory and the following instruction should be located in on-chip RAM.

Figure 17.14 shows the procedure for executing the program/erase control program when transferred to on-chip RAM.

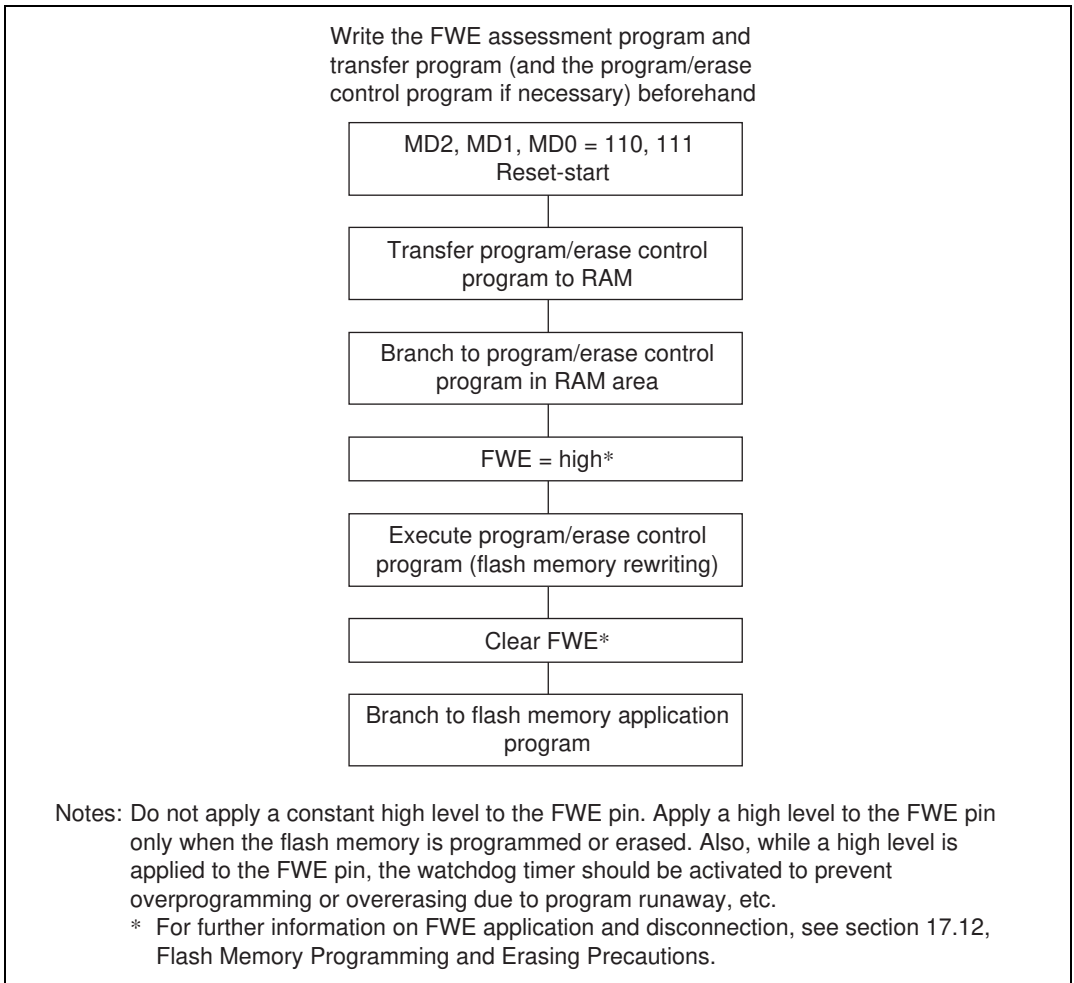

Figure 17.14 User Program Mode Execution Procedure

17.7 Programming/Erasing Flash Memory

In the on-board programming modes, flash memory programming and erasing is performed by software, using the CPU. There are four flash memory operating modes: program mode, erase mode, program-verify mode, and erase-verify mode. Transition to these modes can be made for the on-chip ROM area by setting the PSU, ESU, P, E, PV, and EV bits in FLMCR1.

The flash memory cannot be read while being programmed or erased. Therefore, the program that controls flash memory programming/erasing (the programming control program) should be located and executed in on-chip RAM or external memory. When the program is located in external memory, an instruction for programming the flash memory and the following instruction should be located in on-chip RAM. The DTC should not be activated before or after the instruction for programming the flash memory is executed.

- Notes:
1. Operation is not guaranteed if setting/resetting of the SWE, ESU, PSU, EV, PV, E, and P bits in FLMCR1 is executed by a program in flash memory.
 2. When programming or erasing, set FWE to 1 (programming/erasing will not be executed if FWE = 0).
 3. Perform programming in the erased state. Do not perform additional programming on previously programmed addresses.

17.7.1 Program Mode

Follow the procedure shown in the program/program-verify flowchart in figure 17.15 to write data or programs to flash memory. Performing program operations according to this flowchart will enable data or programs to be written to flash memory without subjecting the device to voltage stress or sacrificing program data reliability. Programming should be carried out 128 bytes at a time.

For the wait times (x , y , $z1$, $z2$, $z3$, α , β , γ , ε , η , θ) after bits are set or cleared in flash memory control register 1 (FLMCR1) and the maximum number of programming operations (N), see section 20.3.6, Flash Memory Characteristics.

Following the elapse of (x) μ s or more after the SWE bit is set to 1 in flash memory control register 1 (FLMCR1), 128-byte program data is stored in the program data area and reprogram data area, and the 128-byte data in the reprogram data area is written consecutively to the write addresses. The lower 8 bits of the first address written to must be H'00 or H'80. 128 consecutive byte data transfers are performed. The program address and program data are latched in the flash memory. A 128-byte data transfer must be performed even if writing fewer than 128 bytes; in this case, H'FF data must be written to the extra addresses.

Next, the watchdog timer is set to prevent overprogramming in the event of program runaway, etc. Set a value greater than $(y + z2 + \alpha + \beta)$ μs as the WDT overflow period. After this, preparation for program mode (program setup) is carried out by setting the PSU bit in FLMCR1, and after the elapse of (y) μs or more, the operating mode is switched to program mode by setting the P bit in FLMCR1. The time during which the P bit is set is the flash memory programming time. Set the programming time according to the table in the programming flowchart.

17.7.2 Program-Verify Mode

In program-verify mode, the data written in program mode is read to check whether it has been correctly written in the flash memory.

After the elapse of a given programming time, the programming mode is exited (the P bit in FLMCR1 is cleared to 0, then the PSU bit is cleared to 0 at least (α) μs later). Next, the watchdog timer is cleared after the elapse of (β) μs or more, and the operating mode is switched to program-verify mode by setting the PV bit in FLMCR1. Before reading in program-verify mode, a dummy write of H'FF data should be made to the addresses to be read. The dummy write should be executed after the elapse of (γ) μs or more. When the flash memory is read in this state (verify data is read in 16-bit units), the data at the latched address is read. Wait at least (ε) μs after the dummy write before performing this read operation. Next, the originally written data is compared with the verify data, and reprogram data is computed (see figure 17.15) and transferred to the reprogram data area. After 128 bytes of data have been verified, exit program-verify mode, wait for at least (η) μs , then clear the SWE bit in FLMCR1 to 0, and wait again for at least (θ) μs . If reprogramming is necessary, set program mode again, and repeat the program/program-verify sequence as before. However, ensure that the program/program-verify sequence is not repeated more than (N) times on the same bits.

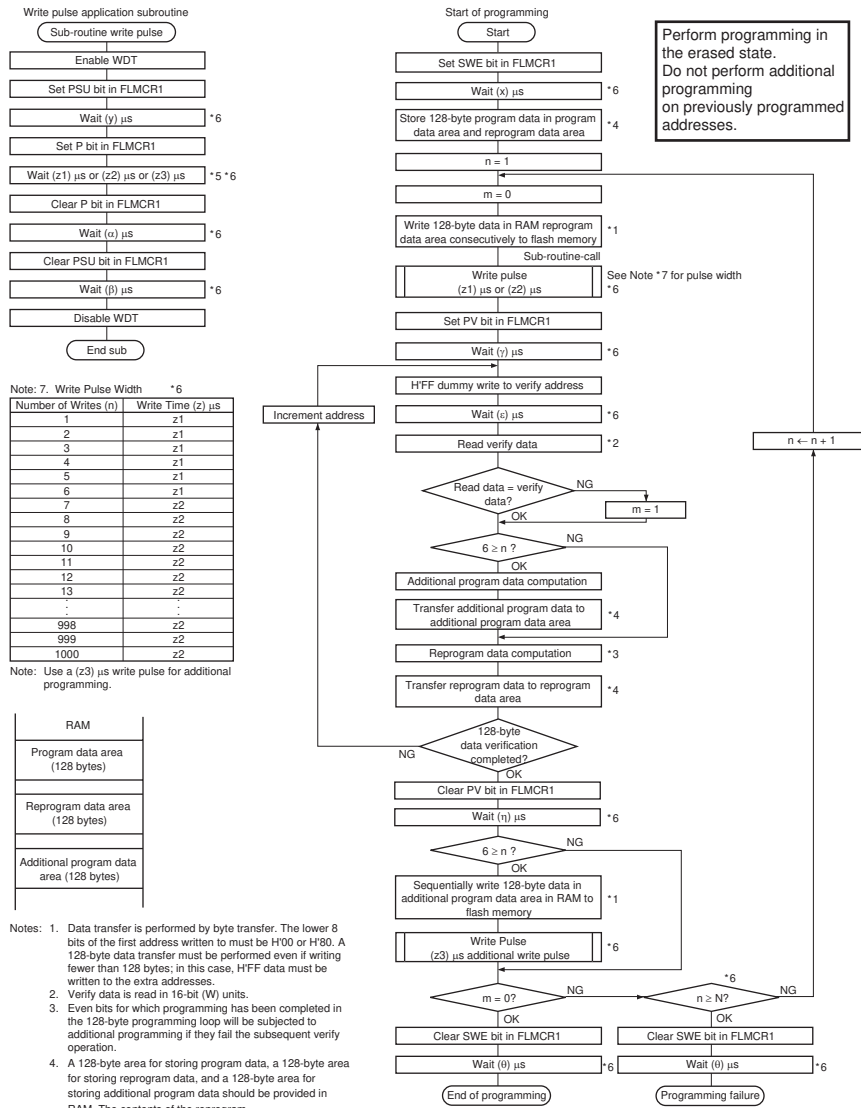

Note: 7. Write Pulse Width *6

Number of Writes (n)	Write Time (z) μ s
1	z1
2	z1
3	z1
4	z1
5	z1
6	z1
7	z2
8	z2
9	z2
10	z2
11	z2
12	z2
13	z2
.	.
998	z2
999	z2
1000	z2

Note: Use a (z3) μ s write pulse for additional programming.

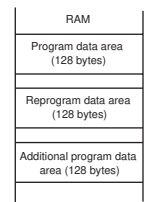

- Notes:
1. Data transfer is performed by byte transfer. The lower 8 bits of the first address written to must be H'00 or H'80. A 128-byte data transfer must be performed even if writing fewer than 128 bytes; in this case, HFF data must be written to the extra addresses.
 2. Verify data is read in 16-bit (W) units.
 3. Even bits for which programming has been completed in the 128-byte programming loop will be subjected to additional programming if they fail the subsequent verify operation.
 4. A 128-byte area for storing program data, a 128-byte area for storing reprogram data, and a 128-byte area for storing additional program data should be provided in RAM. The contents of the reprogram data and additional program data areas are modified as programming proceeds.
 5. A write pulse of (z1) or (z2) ms should be applied according to the progress of programming. See note 7 for the pulse widths. When the additional program data is programmed, a write pulse of (z3) μ s should be applied. Reprogram data 'X' stands for reprogram data to which a write pulse has been applied.
 6. For the values of x, y, z1, z2, z3, α , β , γ , ϵ , η , θ , and N, see section 20.3.6, Flash Memory Characteristics.

Program Data Operation Chart

Original Data (D)	Verify Data (V)	Reprogram Data (X)	Comments
0	0	1	Programming completed
0	1	0	Programming incomplete; reprogram
1	0	1	Still in erased state; no action
1	1		

Additional Program Data Operation Chart

Reprogram Data (X)	Verify Data (V)	Additional Program Data (Y)	Comments
0	0	0	Additional programming executed
0	1	1	Additional programming not executed
1	0		Additional programming not executed
1	1		Additional programming not executed

Figure 17.15 Program/Program-Verify Flowchart



17.7.3 Erase Mode

Flash memory erasing should be performed block by block following the procedure shown in the erase/erase-verify flowchart (single-block erase) shown in figure 17.16.

For the wait times (x , y , z , α , β , γ , ε , η , θ) after bits are set or cleared in flash memory control register 1 (FLMCR1) and the maximum number of programming operations (N), see section 20.3.6, Flash Memory Characteristics.

To perform data or program erasure, make a 1 bit setting for the flash memory area to be erased in erase block register 1 or 2 (EBR1 or EBR2) at least (x) μ s after setting the SWE bit to 1 in flash memory control register 1 (FLMCR1). Next, the watchdog timer is set to prevent overerasing in the event of program runaway, etc. Set a value greater than ($y + z + \alpha + \beta$) ms as the WDT overflow period. After this, preparation for erase mode (erase setup) is carried out by setting the ESU bit in FLMCR1, and after the elapse of (y) μ s or more, the operating mode is switched to erase mode by setting the E bit in FLMCR1. The time during which the E bit is set is the flash memory erase time. Ensure that the erase time does not exceed (z) ms.

Note: With flash memory erasing, prewriting (setting all data in the memory to be erased to 0) is not necessary before starting the erase procedure.

17.7.4 Erase-Verify Mode

In erase-verify mode, data is read after memory has been erased to check whether it has been correctly erased.

After the elapse of the erase time, erase mode is exited (the E bit in FLMCR1 is cleared to 0, then the ESU bit in FLMCR1 is cleared to 0 at least (α) μ s later), the watchdog timer is cleared after the elapse of (β) μ s or more, and the operating mode is switched to erase-verify mode by setting the EV bit in FLMCR1. Before reading in erase-verify mode, a dummy write of H'FF data should be made to the addresses to be read. The dummy write should be executed after the elapse of (γ) μ s or more. When the flash memory is read in this state (verify data is read in 16-bit units), the data at the latched address is read. Wait at least (ε) μ s after the dummy write before performing this read operation. If the read data has been erased (all 1), a dummy write is performed to the next address, and erase-verify is performed. If the read data has not been erased, set erase mode again, and repeat the erase/erase-verify sequence in the same way. However, ensure that the erase/erase-verify sequence is not repeated more than (N) times. When verification is completed, exit erase-verify mode, and wait for at least (η) μ s. If erasure has been completed on all the erase blocks, clear the SWE bit in FLMCR1 to 0 and wait for at least (θ) μ s. If there are any unerased blocks, make a 1 bit setting for the flash memory area to be erased, and repeat the erase/erase-verify sequence in the same way.

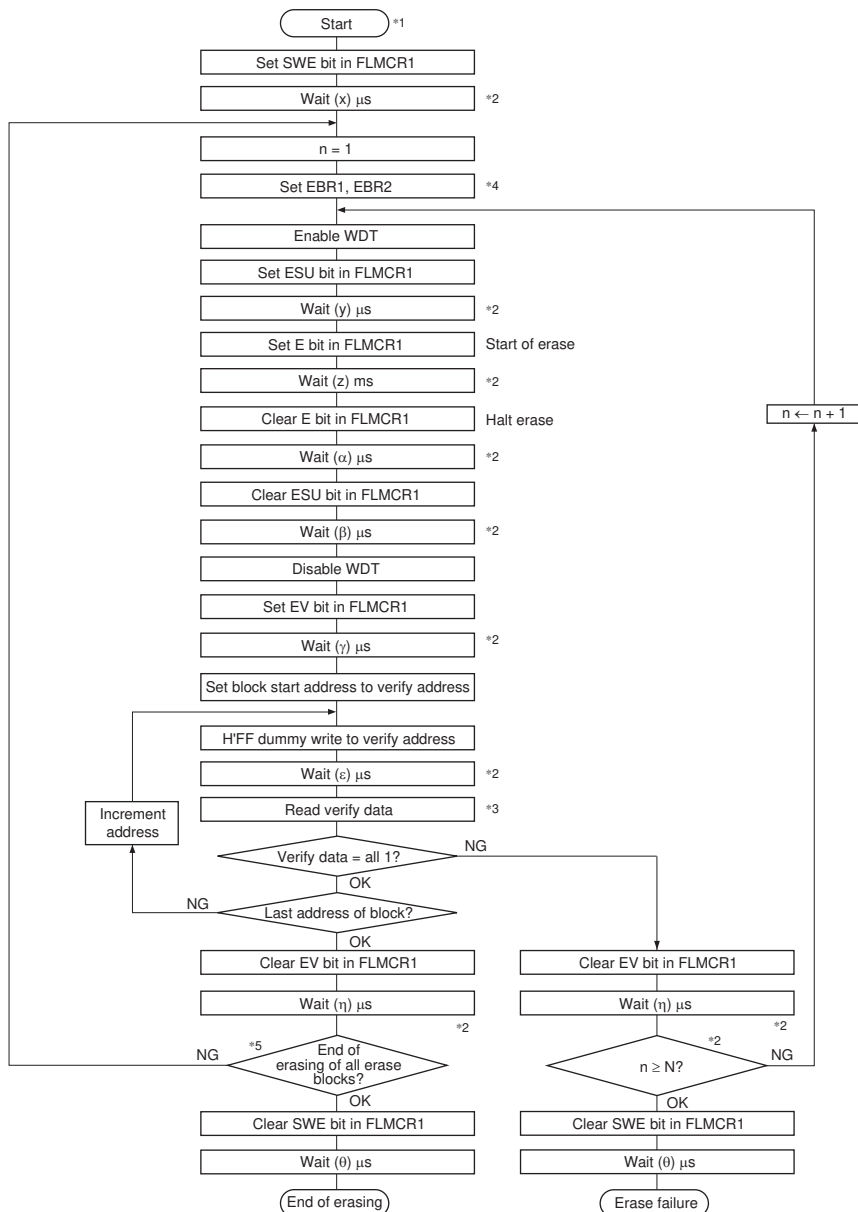

- Notes: 1. Prewriting (setting erase block data to all 0) is not necessary.
 2. The values of x, y, z, α, β, γ, ε, η, θ, and N are shown in section 20.3.6, Flash Memory Characteristics.
 3. Verify data is read in 16-bit (W) units.
 4. Set only one bit in EBR1 or EBR2. More than one bit cannot be set.
 5. Erasing is performed in block units. To erase a number of blocks, the individual blocks must be erased sequentially.

Figure 17.16 Erase/Eraser-Verify Flowchart

17.8 Flash Memory Protection

There are three kinds of flash memory program/erase protection: hardware protection, software protection, and error protection.

17.8.1 Hardware Protection

Hardware protection refers to a state in which programming/erasing of flash memory is forcibly disabled or aborted. Settings in flash memory control registers 1 and 2 (FLMCR1, FLMCR2) and erase block registers 1 and 2 (EBR1, EBR2) are reset (see table 17.11).

Table 17.11 Hardware Protection

Item	Description	Functions	
		Program	Erase
FWE pin protection	<ul style="list-style-type: none"> When a low level is input to the FWE pin, FLMCR1, FLMCR2, EBR1, and EBR2 are initialized, and the program/erase-protected state is entered. 	Yes	Yes
Reset/standby protection	<ul style="list-style-type: none"> In a reset (including a WDT overflow reset) and in standby mode, FLMCR1, FLMCR2, EBR1, and EBR2 are initialized, and the program/erase-protected state is entered. In a reset via the $\overline{\text{RES}}$ pin, the reset state is not entered unless the $\overline{\text{RES}}$ pin is held low until oscillation stabilizes after powering on. In the case of a reset during operation, hold the $\overline{\text{RES}}$ pin low for the $\overline{\text{RES}}$ pulse width specified in section 20.3.3, AC Characteristics. 	Yes	Yes

17.8.2 Software Protection

Software protection can be implemented by setting the SWE bit in flash memory control register 1 (FLMCR1), erase block registers 1 and 2 (EBR1, EBR2), and the RAMS bit in the RAM emulation register (RAMER). When software protection is in effect, setting the P or E bit in FLMCR1 does not cause a transition to program mode or erase mode (see table 17.12).

Table 17.12 Software Protection

Item	Description	Functions	
		Program	Erase
SWE bit protection	<ul style="list-style-type: none"> Clearing the SWE bit to 0 in FLMCR1 sets the program/erase-protected state for all blocks (Execute in on-chip RAM or external memory.) 	Yes	Yes
Block specification protection	<ul style="list-style-type: none"> Erase protection can be set for individual blocks by settings in erase block registers 1 and 2 (EBR1, EBR2). Setting EBR1 and EBR2 to H'00 places all blocks in the erase-protected state. 	—	Yes
Emulation protection	<ul style="list-style-type: none"> Setting the RAMS bit to 1 in the RAM emulation register (RAMER) places all blocks in the program/erase-protected state. 	Yes	Yes

17.8.3 Error Protection

In error protection, an error is detected when MCU runaway occurs during flash memory programming/erasing, or operation is not performed in accordance with the program/erase algorithm, and the program/erase operation is aborted. Aborting the program/erase operation prevents damage to the flash memory due to overprogramming or overerasing.

If the MCU malfunctions during flash memory programming/erasing, the FLER bit is set to 1 in FLMCR2 and the error protection state is entered. The FLMCR1, FLMCR2, EBR1, and EBR2 settings are retained, but program mode or erase mode is aborted at the point at which the error occurred. Program mode or erase mode cannot be re-entered by re-setting the P or E bit. However, PV and EV bit setting is enabled, and a transition can be made to verify mode.

FLER bit setting conditions are as follows:

- When flash memory is read during programming/erasing (including a vector read or instruction fetch)
- Immediately after exception handling (excluding a reset) during programming/erasing
- When a SLEEP instruction (including software standby) is executed during programming/erasing

- When a bus master other than the CPU (the DTC) has control of the bus during programming/erasing

Error protection is released only by a reset and in hardware standby mode.

Figure 17.17 shows the flash memory state transition diagram.

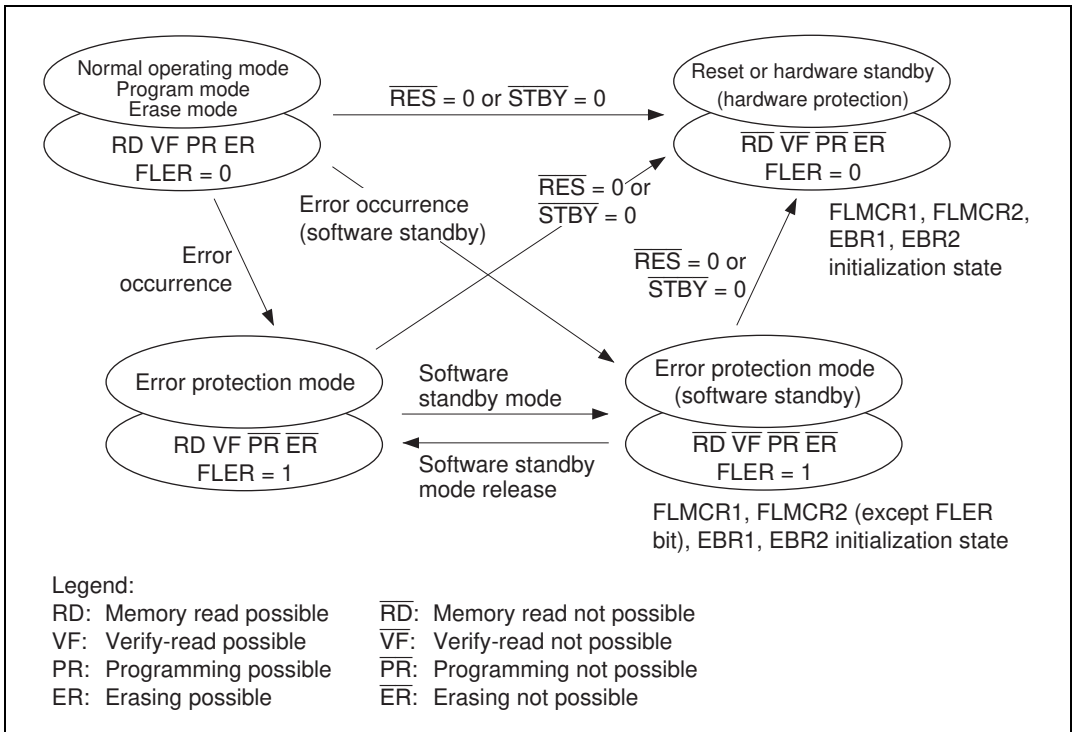

Figure 17.17 Flash Memory State Transitions

17.9 Flash Memory Emulation in RAM

17.9.1 Emulation in RAM

Making a setting in the RAM emulation register (RAMER) enables part of RAM to be overlapped onto the flash memory area so that data to be written to flash memory can be emulated in RAM in real time. After the RAMER setting has been made, accesses can be made from the flash memory area or the RAM area overlapping flash memory. Emulation can be performed in user mode and user program mode. Figure 17.18 shows an example of emulation of real-time flash memory programming.

Note: Flash memory emulation by RAM is not supported in the H8S/2314 F-ZTAT.

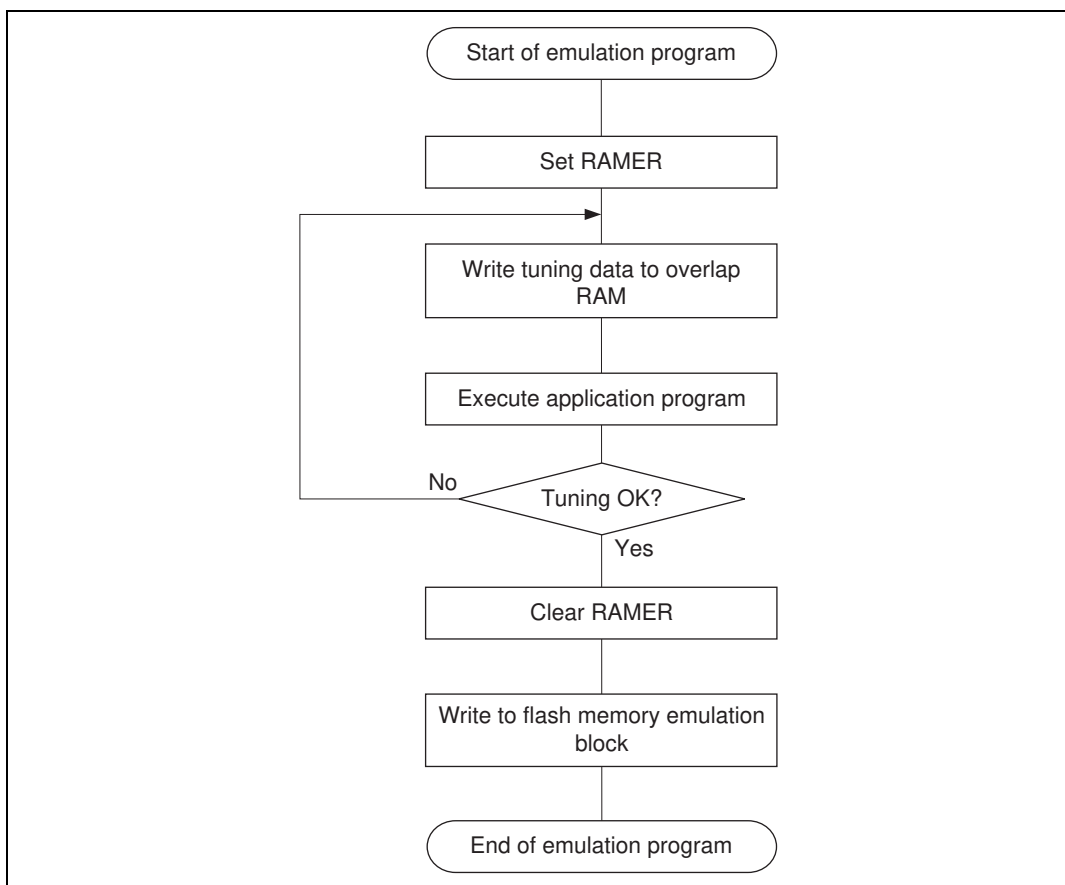

Figure 17.18 Flowchart for Flash Memory Emulation in RAM

17.9.2 RAM Overlap

An example in which flash memory block area EB1 is overlapped is shown below.

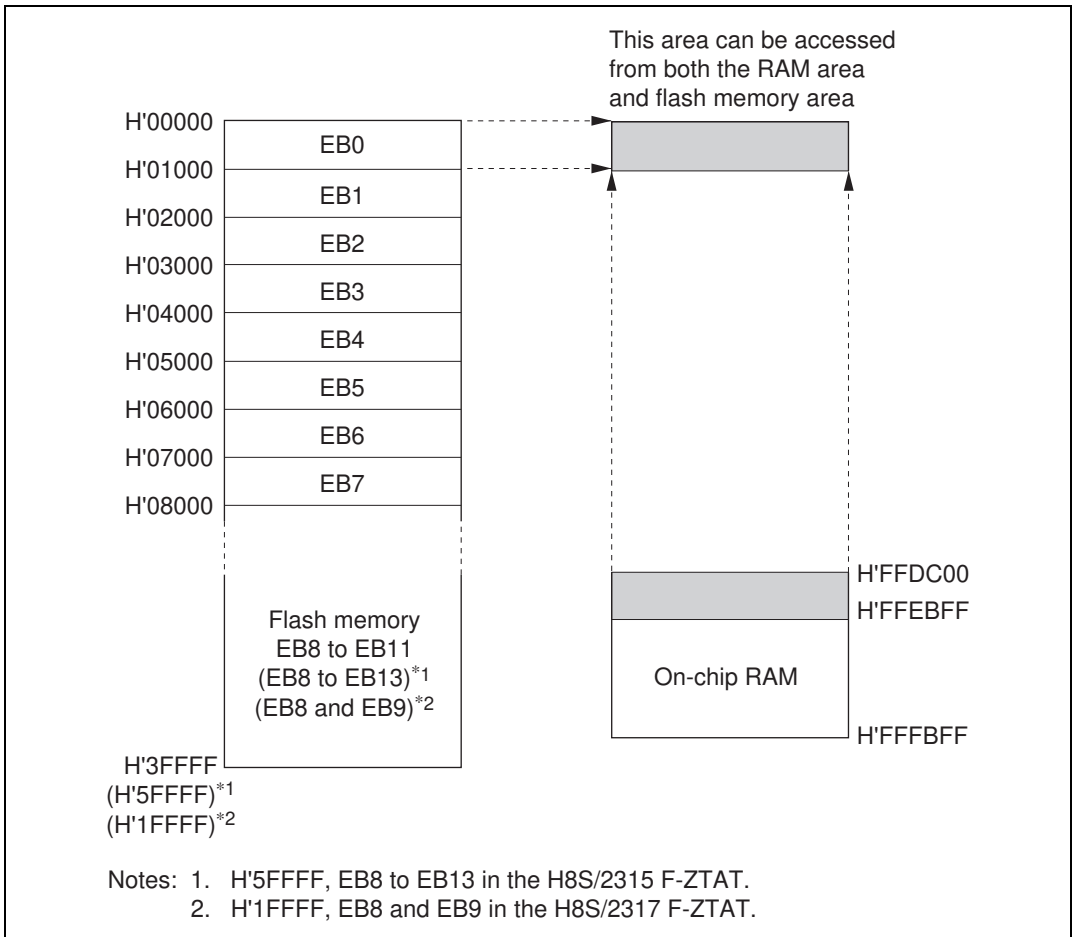

Figure 17.19 Example of RAM Overlap Operation

Example in Which Flash Memory Block Area EB1 Is Overlapped

1. Set bits RAMS, RAM2, RAM1, and RAM0 in RAMER to 1, 0, 0, 1, to overlap part of RAM onto the area (EB1) for which real-time programming is required.
2. Real-time programming is performed using the overlapping RAM.
3. After the program data has been confirmed, the RAMS bit is cleared, releasing RAM overlap.
4. The data written in the overlapping RAM is written into the flash memory space (EB1).

- Notes:
1. When the RAMS bit is set to 1, program/erase protection is enabled for all blocks regardless of the value of RAM2, RAM1, and RAM0 (emulation protection). In this state, setting the P or E bit in flash memory control register 1 (FLMCR1) will not cause a transition to program mode or erase mode. When actually programming a flash memory area, the RAMS bit should be cleared to 0.
 2. A RAM area cannot be erased by execution of software in accordance with the erase algorithm while flash memory emulation in RAM is being used.
 3. Block area EBO includes the vector table. When performing RAM emulation, the vector table is needed by the overlap RAM.

17.10 Interrupt Handling when Programming/Erasing Flash Memory

All interrupts, including NMI input, are disabled when flash memory is being programmed or erased (when the P or E bit is set in FLMCR1), and while the boot program is executing in boot mode*¹, to give priority to the program or erase operation. There are three reasons for this:

1. Interrupt during programming or erasing might cause a violation of the programming or erasing algorithm, with the result that normal operation could not be assured.
2. In the interrupt exception handling sequence during programming or erasing, the vector would not be read correctly*², possibly resulting in MCU runaway.
3. If an interrupt occurred during boot program execution, it would not be possible to execute the normal boot mode sequence.

For these reasons, in on-board programming mode alone there are conditions for disabling interrupts, as an exception to the general rule. However, this provision does not guarantee normal erasing and programming or MCU operation. All interrupt requests, including NMI, must therefore be restricted inside and outside the MCU when programming or erasing flash memory. The NMI interrupt is also disabled in the error-protection state while the P or E bit remains set in FLMCR1.

- Notes:
1. Interrupt requests must be disabled inside and outside the MCU until the programming control program has completed programming.
 2. The vector may not be read correctly in this case for the following two reasons:
 - If flash memory is read while being programmed or erased (while the P or E bit is set in FLMCR1), correct read data will not be obtained (undetermined values will be returned).
 - If the interrupt entry in the vector table has not been programmed yet, interrupt exception handling will not be executed correctly.

17.11 Flash Memory Programmer Mode

17.11.1 Programmer Mode Setting

Programs and data can be written and erased in programmer mode as well as in the on-board programming modes. In programmer mode, the on-chip ROM can be freely programmed using a PROM programmer* that supports the Renesas Technology microcomputer device type with 256-kbyte on-chip flash memory (FZTAT256V3A). Flash memory read mode, auto-program mode, auto-erase mode, and status read mode are supported with this device type. In auto-program mode, auto-erase mode, and status read mode, a status polling procedure is used, and in status read mode, detailed internal signals are output after execution of an auto-program or auto-erase operation.

Note: * In the H8S/2315 F-ZTAT and H8S/2314 F-ZTAT, a PROM programmer that supports the Renesas Technology microcomputer device type with 512-kbyte on-chip flash memory (FZTAT512V3A) is used.

Table 17.13 shows programmer mode pin settings.

Table 17.13 Programmer Mode Pin Settings

Pin Names	Settings/External Circuit Connection
Mode pins: MD2, MD1, MD0	Low-level input
Mode setting pins: PF2, PF1, PF0	High-level input to PF2, low-level input to PF1 and PF0
FWE pin	High-level input (in auto-program and auto-erase modes)
$\overline{\text{STBY}}$ pin	High-level input (do not select hardware standby mode)
NMI pin	High-level input
$\overline{\text{RES}}$ pin	Reset circuit
XTAL, EXTAL pins	Oscillator circuit
Other pins requiring setting: P23, P25	High-level input to P23, low-level input to P25

17.11.2 Socket Adapters and Memory Map

In programmer mode, a socket adapter is connected to the chip as shown in figure 17.21. This enables the chip to fit a 40-pin socket. Figure 17.20 shows the on-chip ROM memory map and figure 17.21 shows the socket adapter pin assignments.

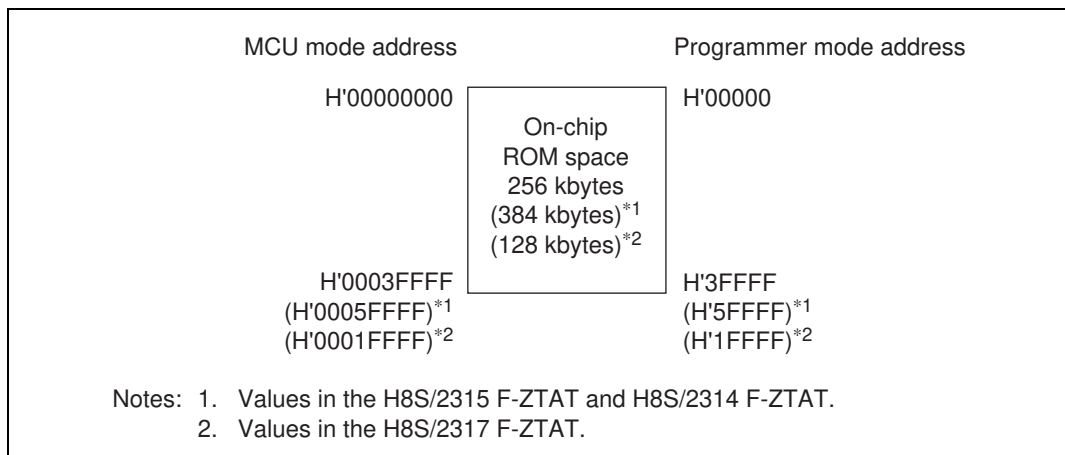

Figure 17.20 Memory Map in PROM Mode

H8S/2318 F-ZTAT, H8S/2317 F-ZTAT, H8S/2315 F-ZTAT, H8S/2314 F-ZTAT			Socket Adapter (40-Pin Conversion)	HN27C4096HG (40 Pins)	
TFP-100B, TFP-100G	FP-100A	Pin Name		Pin No.	Pin Name
32	34	A ₀		21	A ₀
33	35	A ₁		22	A ₁
34	36	A ₂		23	A ₂
35	37	A ₃		24	A ₃
36	38	A ₄		25	A ₄
37	39	A ₅		26	A ₅
38	40	A ₆		27	A ₆
39	41	A ₇		28	A ₇
41	43	A ₈		29	A ₈
42	44	A ₉		31	A ₉
43	45	A ₁₀		32	A ₁₀
44	46	A ₁₁		33	A ₁₁
45	47	A ₁₂		34	A ₁₂
46	48	A ₁₃		35	A ₁₃
47	49	A ₁₄		36	A ₁₄
48	50	A ₁₅		37	A ₁₅
50	52	A ₁₆		38	A ₁₆
51	53	A ₁₇		39	A ₁₇
52	54	A ₁₈		10	A ₁₈
53	55	A ₁₉		9	A ₁₉
99	1	A ₂₀		8	A ₂₀
23	25	D ₈		19	I/O ₀
24	26	D ₉		18	I/O ₁
25	27	D ₁₀		17	I/O ₂
26	28	D ₁₁		16	I/O ₃
27	29	D ₁₂		15	I/O ₄
28	30	D ₁₃		14	I/O ₅
29	31	D ₁₄		13	I/O ₆
30	32	D ₁₅		12	I/O ₇
55	57	CE		2	CE
54	56	OE		20	OE
56	58	WE		3	WE
60	62	FWE		4	FWE
40, 63, 64, 65, 74, 77, 78, 98, 59	42, 65, 66, 67, 76, 79, 80, 100, 61	V _{CC}		1, 40	V _{CC}
7, 18, 31, 49, 57, 58, 61, 68, 75, 76, 87, 88, 90	9, 20, 33, 51, 59, 60, 63, 70, 77, 78, 89, 90, 92	V _{SS}		11, 30	V _{SS}
62	64	RES	Reset circuit	5, 6, 7	NC
66	68	XTAL	Oscillation circuit		
67	69	EXTAL			
Other pins		NC (OPEN)			

Notes: This figure shows pin assignments, and does not show the entire socket adapter circuit.

1. A reset oscillation stabilization time (t_{OSCT}) of at least 10 ms is required.
2. A 12-MHz crystal resonator should be used.

**Figure 17.21 H8S/2318 F-ZTAT, H8S/2317 F-ZTAT, H8S/2315 F-ZTAT,
H8S/2314 F-ZTAT Socket Adapter Pin Assignments**

17.11.3 Programmer Mode Operation

Table 17.14 shows how the different operating modes are set when using programmer mode, and table 17.15 lists the commands used in programmer mode. Details of each mode are given below.

Memory Read Mode: Memory read mode supports byte reads.

Auto-Program Mode: Auto-program mode supports programming of 128 bytes at a time. Status polling is used to confirm the end of auto-programming.

Auto-Erase Mode: Auto-erase mode supports automatic erasing of the entire flash memory. Status polling is used to confirm the end of auto-erasing.

Status Read Mode: Status polling is used for auto-programming and auto-erasing, and normal termination can be confirmed by reading the I/O₆ signal. In status read mode, error information is output if an error occurs.

Table 17.14 Settings for Each Operating Mode in Programmer Mode

Mode	Pin Names					
	FWE	\overline{CE}	\overline{OE}	\overline{WE}	I/O ₇ to I/O ₀	A ₁₈ to A ₀
Read	H or L	L	L	H	Data output	Ain
Output disable	H or L	L	H	H	Hi-Z	×
Command write	H or L ^{*3}	L	H	L	Data input	Ain ^{*2}
Chip disable ^{*1}	H or L	H	×	×	Hi-Z	×

Legend:

H: High level

L: Low level

Hi-Z: High impedance

×: Don't care

Notes: 1. Chip disable is not a standby state; internally, it is an operation state.

2. Ain indicates that there is also address input in auto-program mode.

3. For command writes when making a transition to auto-program or auto-erase mode, input a high level to the FWE pin.

Table 17.15 Programmer Mode Commands

Command Name	Number of Cycles	1st Cycle			2nd Cycle		
		Mode	Address	Data	Mode	Address	Data
Memory read mode	1 + n	Write	×	H'00	Read	RA	Dout
Auto-program mode	129	Write	×	H'40	Write	PA	Din
Auto-erase mode	2	Write	×	H'20	Write	×	H'20
Status read mode	2	Write	×	H'71	Write	×	H'71

Legend:

RA: Read address

PA: Program address

×: Don't care

Notes: 1. In auto-program mode, 129 cycles are required for command writing by a simultaneous 128-byte write.

2. In memory read mode, the number of cycles depends on the number of address write cycles (n).

17.11.4 Memory Read Mode

- After the end of an auto-program, auto-erase, or status read operation, the command wait state is entered. To read memory contents, a transition must be made to memory read mode by means of a command write before the read is executed.
- Command writes can be performed in memory read mode, just as in the command wait state.
- Once memory read mode has been entered, consecutive reads can be performed.
- After power-on, memory read mode is entered.

Table 17.16 AC Characteristics in Memory Read Mode

Conditions: $V_{CC} = 3.3\text{ V} \pm 0.3\text{ V}$, $V_{SS} = 0\text{ V}$, $T_a = 25^\circ\text{C} \pm 5^\circ\text{C}$

Item	Symbol	Min	Max	Unit
Command write cycle	t_{nxtc}	20	—	μs
$\overline{\text{CE}}$ hold time	t_{ceh}	0	—	ns
$\overline{\text{CE}}$ setup time	t_{ces}	0	—	ns
Data hold time	t_{dh}	50	—	ns
Data setup time	t_{ds}	50	—	ns
Write pulse width	t_{wep}	70	—	ns
$\overline{\text{WE}}$ rise time	t_r	—	30	ns
$\overline{\text{WE}}$ fall time	t_f	—	30	ns

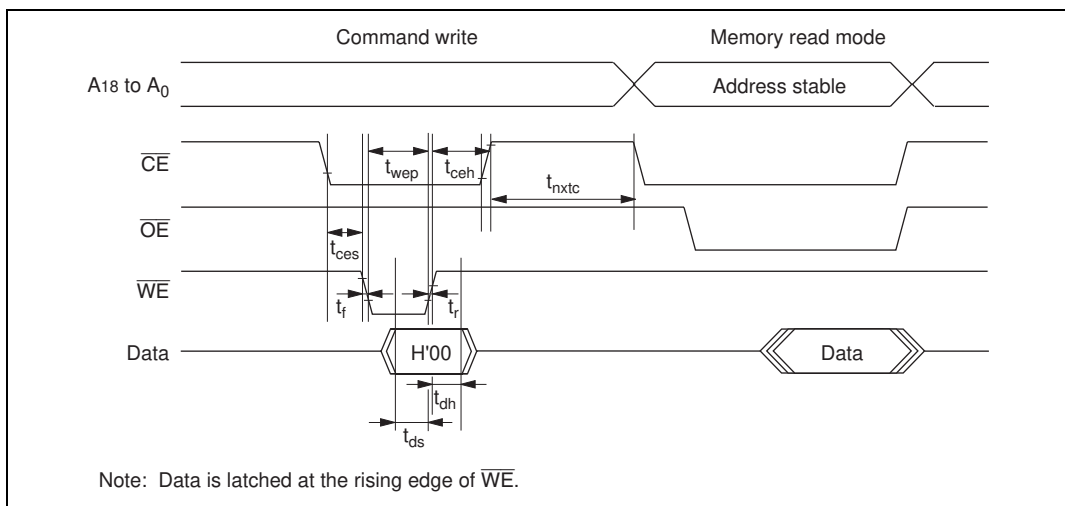

Figure 17.22 Memory Read Mode Timing Waveforms after Command Write

Table 17.17 AC Characteristics when Entering Another Mode from Memory Read ModeConditions: $V_{CC} = 3.3 \text{ V} \pm 0.3 \text{ V}$, $V_{SS} = 0 \text{ V}$, $T_a = 25^\circ\text{C} \pm 5^\circ\text{C}$

Item	Symbol	Min	Max	Unit
Command write cycle	t_{nxtc}	20	—	μs
$\overline{\text{CE}}$ hold time	t_{ceh}	0	—	ns
$\overline{\text{CE}}$ setup time	t_{ces}	0	—	ns
Data hold time	t_{dh}	50	—	ns
Data setup time	t_{ds}	50	—	ns
Write pulse width	t_{wep}	70	—	ns
$\overline{\text{WE}}$ rise time	t_r	—	30	ns
$\overline{\text{WE}}$ fall time	t_f	—	30	ns

**Figure 17.23 Timing Waveforms when Entering Another Mode from Memory Read Mode**

Table 17.18 AC Characteristics in Memory Read ModeConditions: $V_{CC} = 3.3\text{ V} \pm 0.3\text{ V}$, $V_{SS} = 0\text{ V}$, $T_a = 25^\circ\text{C} \pm 5^\circ\text{C}$

Item	Symbol	Min	Max	Unit
Access time	t_{acc}	—	20	μs
$\overline{\text{CE}}$ output delay time	t_{ce}	—	150	ns
$\overline{\text{OE}}$ output delay time	t_{oe}	—	150	ns
Output disable delay time	t_{df}	—	100	ns
Data output hold time	t_{oh}	5	—	ns

**Figure 17.24 Timing Waveforms for $\overline{\text{CE}}/\overline{\text{OE}}$ Enable State Read****Figure 17.25 Timing Waveforms for $\overline{\text{CE}}/\overline{\text{OE}}$ Clocked Read**

17.11.5 Auto-Program Mode

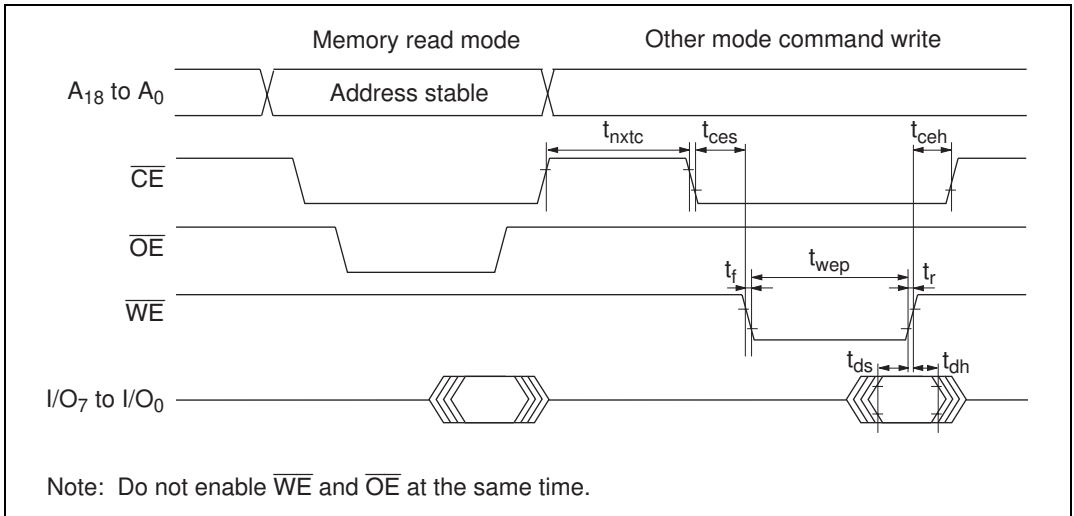
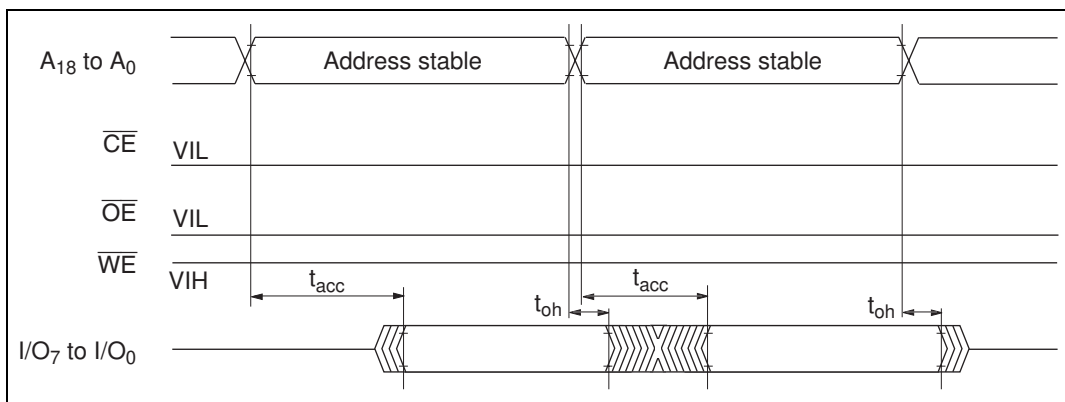
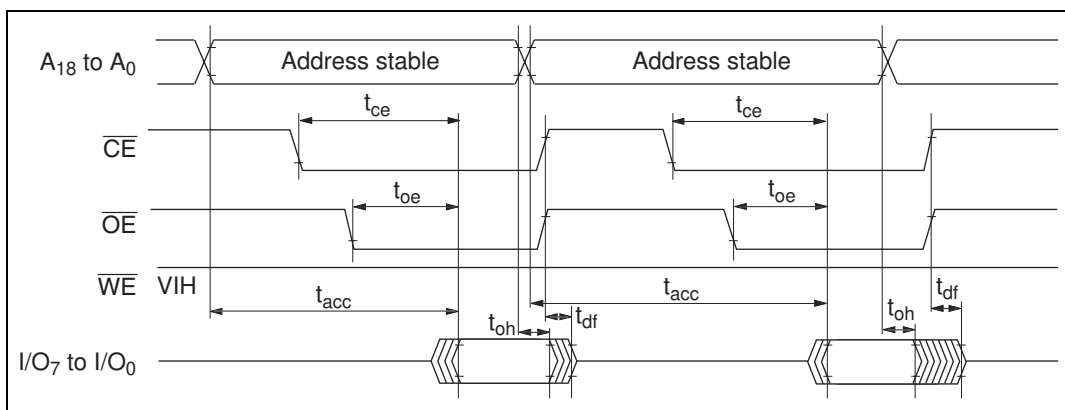
- In auto-program mode, 128 bytes are programmed simultaneously. For this purpose, 128 consecutive byte data transfers should be performed.
- A 128-byte data transfer must be performed even if writing fewer than 128 bytes; in this case, H'FF data must be written to the extra addresses.
- The lower 7 bits of the transfer address must be held low. If an invalid address is input, memory programming will be started but a programming error will occur.
- Memory address transfer is executed in the second cycle (figure 17.26). Do not perform transfer later than the second cycle.
- Do not perform a command write during a programming operation.
- Perform one auto-programming operation for a 128-byte block for each address. One or more additional programming operations cannot be carried out on address blocks that have already been programmed.
- Confirm normal end of auto-programming by checking I/O₆. Alternatively, status read mode can also be used for this purpose (the I/O₇ status polling pin is used to identify the end of an auto-program operation).
- Status polling I/O₆ and I/O₇ information is retained until the next command write. As long as the next command write has not been performed, reading is possible by enabling \overline{CE} and \overline{OE} .

AC Characteristics

Table 17.19 AC Characteristics in Auto-Program Mode

Conditions: $V_{CC} = 3.3 \text{ V} \pm 0.3 \text{ V}$, $V_{SS} = 0 \text{ V}$, $T_a = 25^\circ\text{C} \pm 5^\circ\text{C}$

Item	Symbol	Min	Max	Unit
Command write cycle	t_{nxtc}	20	—	μs
$\overline{\text{CE}}$ hold time	t_{ceh}	0	—	ns
$\overline{\text{CE}}$ setup time	t_{ces}	0	—	ns
Data hold time	t_{dh}	50	—	ns
Data setup time	t_{ds}	50	—	ns
Write pulse width	t_{wep}	70	—	ns
Status polling start time	t_{wsts}	1	—	ms
Status polling access time	t_{spa}	—	150	ns
Address setup time	t_{as}	0	—	ns
Address hold time	t_{ah}	60	—	ns
Memory write time	t_{write}	1	3000	ms
Write setup time	t_{pns}	100	—	ns
Write end setup time	t_{pnh}	100	—	ns
$\overline{\text{WE}}$ rise time	t_r	—	30	ns
$\overline{\text{WE}}$ fall time	t_f	—	30	ns

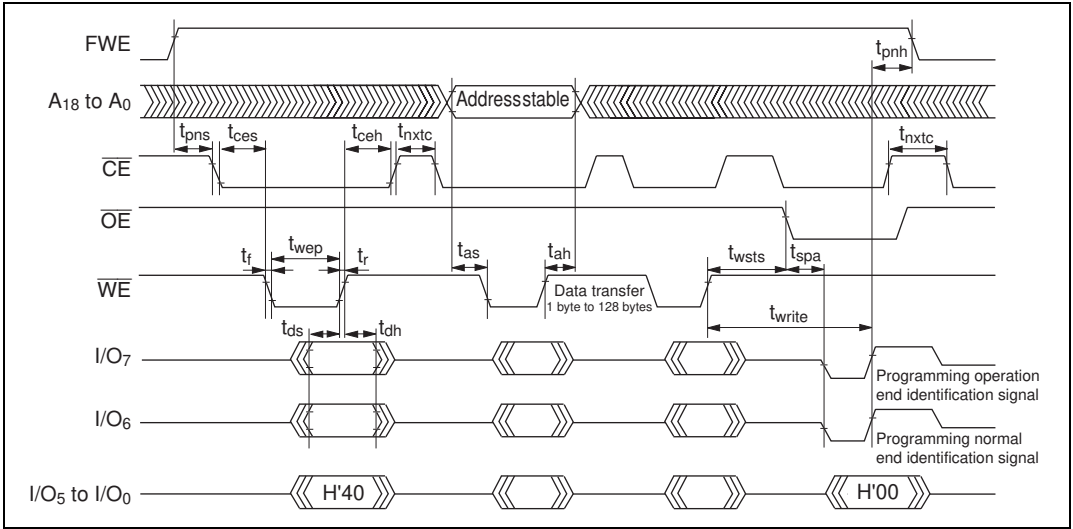

Figure 17.26 Auto-Program Mode Timing Waveforms

17.11.6 Auto-Erase Mode

- Auto-erase mode supports only total memory erasing.
- Do not perform a command write during auto-erasing.
- Confirm normal end of auto-erasing by checking I/O₆. Alternatively, status read mode can also be used for this purpose (the I/O₇ status polling pin is used to identify the end of an auto-erase operation).
- Status polling I/O₆ and I/O₇ pin information is retained until the next command write. As long as the next command write has not been performed, reading is possible by enabling \overline{CE} and \overline{OE} .

AC Characteristics

Table 17.20 AC Characteristics in Auto-Erase Mode

Conditions: $V_{CC} = 3.3\text{ V} \pm 0.3\text{ V}$, $V_{SS} = 0\text{ V}$, $T_a = 25^\circ\text{C} \pm 5^\circ\text{C}$

Item	Symbol	Min	Max	Unit
Command write cycle	t_{nxtc}	20	—	μs
$\overline{\text{CE}}$ hold time	t_{ceh}	0	—	ns
$\overline{\text{CE}}$ setup time	t_{ces}	0	—	ns
Data hold time	t_{dh}	50	—	ns
Data setup time	t_{ds}	50	—	ns
Write pulse width	t_{wep}	70	—	ns
Status polling start time	t_{ests}	1	—	ms
Status polling access time	t_{spa}	—	150	ns
Memory erase time	t_{erase}	100	40000	ms
Erase setup time	t_{ens}	100	—	ns
Erase end setup time	t_{enh}	100	—	ns
$\overline{\text{WE}}$ rise time	t_r	—	30	ns
$\overline{\text{WE}}$ fall time	t_f	—	30	ns

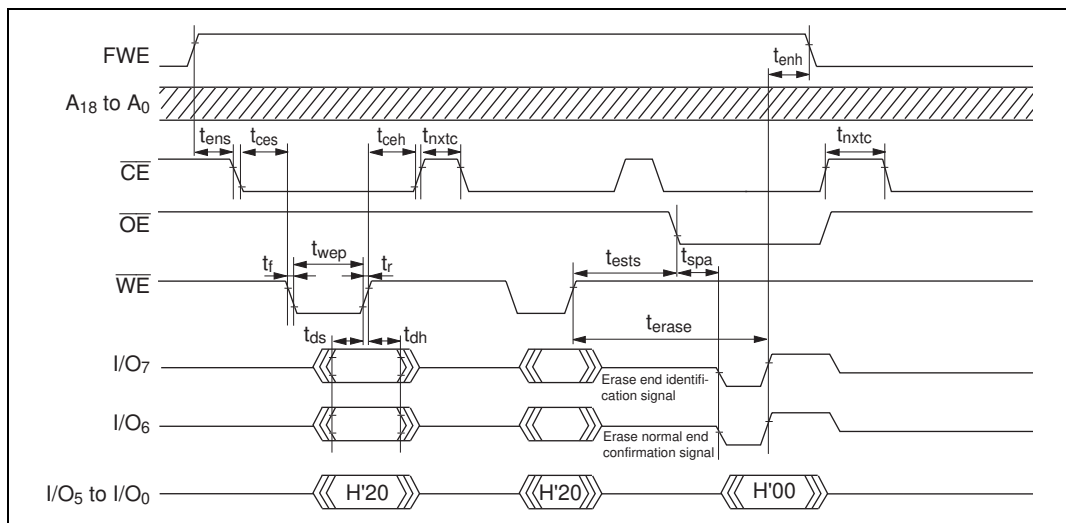

Figure 17.27 Auto-Erase Mode Timing Waveforms

17.11.7 Status Read Mode

- Status read mode is used to identify what type of abnormal end has occurred. Use this mode when an abnormal end occurs in auto-program mode or auto-erase mode.
- The return code is retained until a command write for other than status read mode is performed.

Table 17.21 AC Characteristics in Status Read Mode

Conditions: $V_{CC} = 3.3 \text{ V} \pm 0.3 \text{ V}$, $V_{SS} = 0 \text{ V}$, $T_a = 25^\circ\text{C} \pm 5^\circ\text{C}$

Item	Symbol	Min	Max	Unit
Command write cycle	t_{nxtc}	20	—	μs
$\overline{\text{CE}}$ hold time	t_{ceh}	0	—	ns
$\overline{\text{CE}}$ setup time	t_{ces}	0	—	ns
Data hold time	t_{dh}	50	—	ns
Data setup time	t_{ds}	50	—	ns
Write pulse width	t_{wep}	70	—	ns
$\overline{\text{OE}}$ output delay time	t_{oe}	—	150	ns
Disable delay time	t_{df}	—	100	ns
$\overline{\text{CE}}$ output delay time	t_{ce}	—	150	ns
$\overline{\text{WE}}$ rise time	t_r	—	30	ns
$\overline{\text{WE}}$ fall time	t_f	—	30	ns

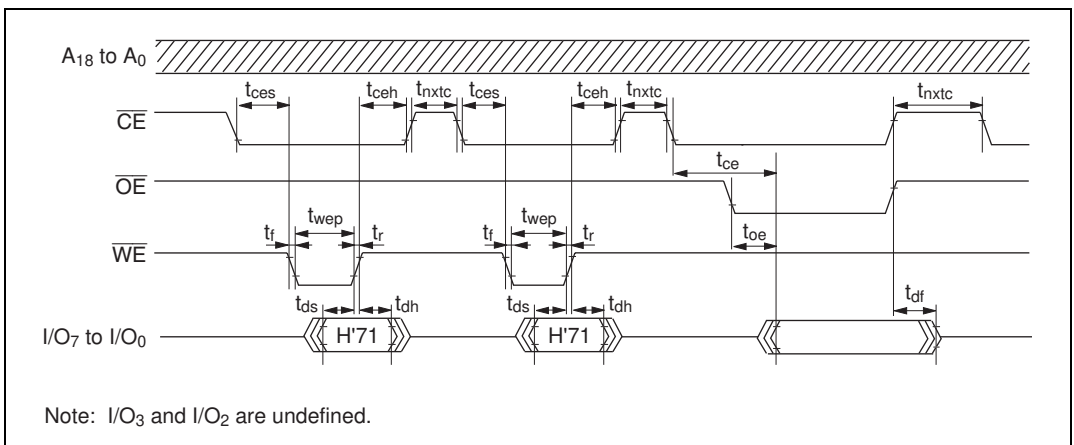

Figure 17.28 Status Read Mode Timing Waveforms

Table 17.22 Status Read Mode Return Commands

Pin Name	I/O ₇	I/O ₆	I/O ₅	I/O ₄	I/O ₃	I/O ₂	I/O ₁	I/O ₀
Attribute	Normal end identification	Command error	Programming error	Erase error	—	—	Programming or erase count exceeded	Effective address error
Initial value	0	0	0	0	0	0	0	0
Indications	Normal end: 0 Abnormal end: 1	Command error: 1 Otherwise: 0	Programming error: 1 Otherwise: 0	Erase error: 1 Otherwise: 0	—	—	Count exceeded: 1 Otherwise: 0	Effective address error: 1 Otherwise: 0

Note: I/O₃ and I/O₂ are undefined.

17.11.8 Status Polling

- The I/O₇ status polling flag indicates the operating status in auto-program or auto-erase mode.
- The I/O₆ status polling flag indicates a normal or abnormal end in auto-program or auto-erase mode.

Table 17.23 Status Polling Output Truth Table

Pin Names	Internal Operation		—	Normal End
	in Progress	Abnormal End		
I/O ₇	0	1	0	1
I/O ₆	0	0	1	1
I/O ₀ to I/O ₅	0	0	0	0

17.11.9 Programmer Mode Transition Time

Commands cannot be accepted during the oscillation stabilization period or the programmer mode setup period. After the programmer mode setup time, a transition is made to memory read mode.

Table 17.24 Command Wait State Transition Time Specifications

Item	Symbol	Min	Max	Unit
Standby release (oscillation stabilization time)	t_{osc1}	30	—	ms
Programmer mode setup time	t_{bmV}	10	—	ms
V_{CC} hold time	t_{dwn}	0	—	ms

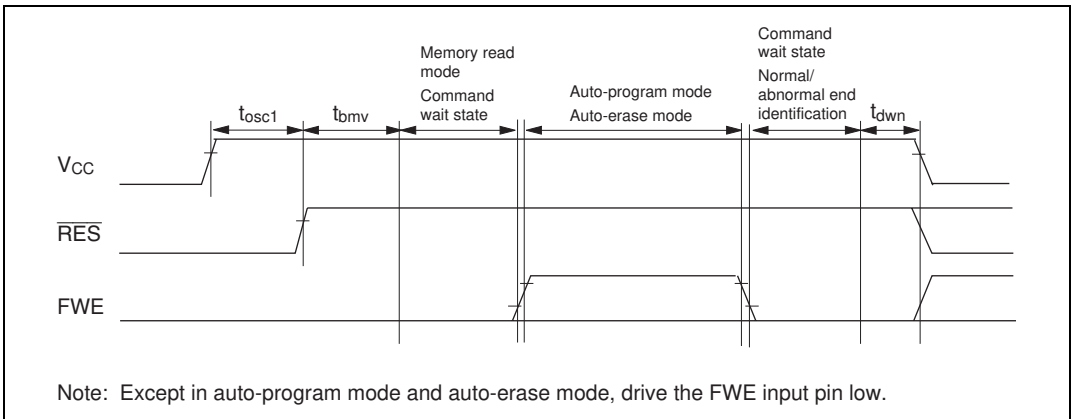

Figure 17.29 Oscillation Stabilization Time, Programmer Mode Setup Time, and Power Supply Fall Sequence

17.11.10 Notes on Memory Programming

- When programming addresses which have previously been programmed, carry out auto-erasing before auto-programming.
- When performing programming using PROM mode on a chip that has been programmed/erased in an on-board programming mode, auto-erasing is recommended before carrying out auto-programming.

Notes: 1. The flash memory is initially in the erased state when the device is shipped by Renesas Technology. For other chips for which the erasure history is unknown, it is recommended that auto-erasing be executed to check and supplement the initialization (erase) level.

2. Auto-programming should be performed once only on the same address block. Additional programming cannot be carried out on address blocks that have already been programmed.

17.12 Flash Memory Programming and Erasing Precautions

Precautions concerning the use of on-board programming mode, the RAM emulation function, and PROM mode are summarized below.

Use the specified voltages and timing for programming and erasing: Applied voltages in excess of the rating can permanently damage the device. Use a PROM programmer that supports the Renesas Technology microcomputer device type with 256-kbyte on-chip flash memory (FZTAT256V3A) or the Renesas Technology microcomputer device type with 512-kbyte on-chip flash memory (FZTAT512V3A).

Do not select the HN27C4096 setting for the PROM programmer, and only use the specified socket adapter. Failure to observe these points may result in damage to the device.

Powering on and off (see figures 17.30 to 17.32): Do not apply a high level to the FWE pin until V_{CC} has stabilized. Also, drive the FWE pin low before turning off V_{CC} .

When applying or disconnecting V_{CC} power, fix the FWE pin low and place the flash memory in the hardware protection state.

The power-on and power-off timing requirements should also be satisfied in the event of a power failure and subsequent recovery.

FWE application/disconnection (see figures 17.30 to 17.32): FWE application should be carried out when MCU operation is in a stable condition. If MCU operation is not stable, fix the FWE pin low and set the protection state.

The following points must be observed concerning FWE application and disconnection to prevent unintentional programming or erasing of flash memory:

- Apply FWE when the V_{CC} voltage has stabilized within its rated voltage range.
Apply FWE when oscillation has stabilized (after the elapse of the oscillation stabilization time).
- In boot mode, apply and disconnect FWE during a reset.
- In user program mode, FWE can be switched between high and low level regardless of the reset state. FWE input can also be switched during execution of a program in flash memory.
- Do not apply FWE if program runaway has occurred.
- Disconnect FWE only when the SWE, ESU, PSU, EV, PV, P, and E bits in FLMCR1 are cleared.
Make sure that the SWE, ESU, PSU, EV, PV, P, and E bits are not set by mistake when applying or disconnecting FWE.

Do not apply a constant high level to the FWE pin: Apply a high level to the FWE pin only when programming or erasing flash memory. A system configuration in which a high level is constantly applied to the FWE pin should be avoided. Also, while a high level is applied to the FWE pin, the watchdog timer should be activated to prevent overprogramming or overerasing due to program runaway, etc.

Use the recommended algorithm when programming and erasing flash memory: The recommended algorithm enables programming and erasing to be carried out without subjecting the device to voltage stress or sacrificing program data reliability. When setting the P or E bit in FLMCR1, the watchdog timer should be set beforehand as a precaution against program runaway, etc.

Do not set or clear the SWE bit during execution of a program in flash memory: Wait for at least 100 μ s after clearing the SWE bit before executing a program or reading data in flash memory. When the SWE bit is set, data in flash memory can be rewritten, but when $SWE = 1$, flash memory can only be read in program-verify or erase-verify mode. Access flash memory only for verify operations (verification during programming/erasing). Also, do not clear the SWE bit during programming, erasing, or verifying.

Similarly, when using the RAM emulation function while a high level is being input to the FWE pin, the SWE bit must be cleared before executing a program or reading data in flash memory.

However, the RAM area overlapping flash memory space can be read and written to regardless of whether the SWE bit is set or cleared.

Do not use interrupts while flash memory is being programmed or erased: All interrupt requests, including NMI, should be disabled during FWE application to give priority to program/erase operations.

Do not perform additional programming. Erase the memory before reprogramming: In on-board programming, perform only one programming operation on a 128-byte programming unit block. In PROM mode, too, perform only one programming operation on a 128-byte programming unit block. Programming should be carried out with the entire programming unit block erased.

Before programming, check that the chip is correctly mounted in the PROM programmer: Overcurrent damage to the device can result if the index marks on the PROM programmer socket, socket adapter, and chip are not correctly aligned.

Do not touch the socket adapter or chip during programming: Touching either of these can cause contact faults and write errors.

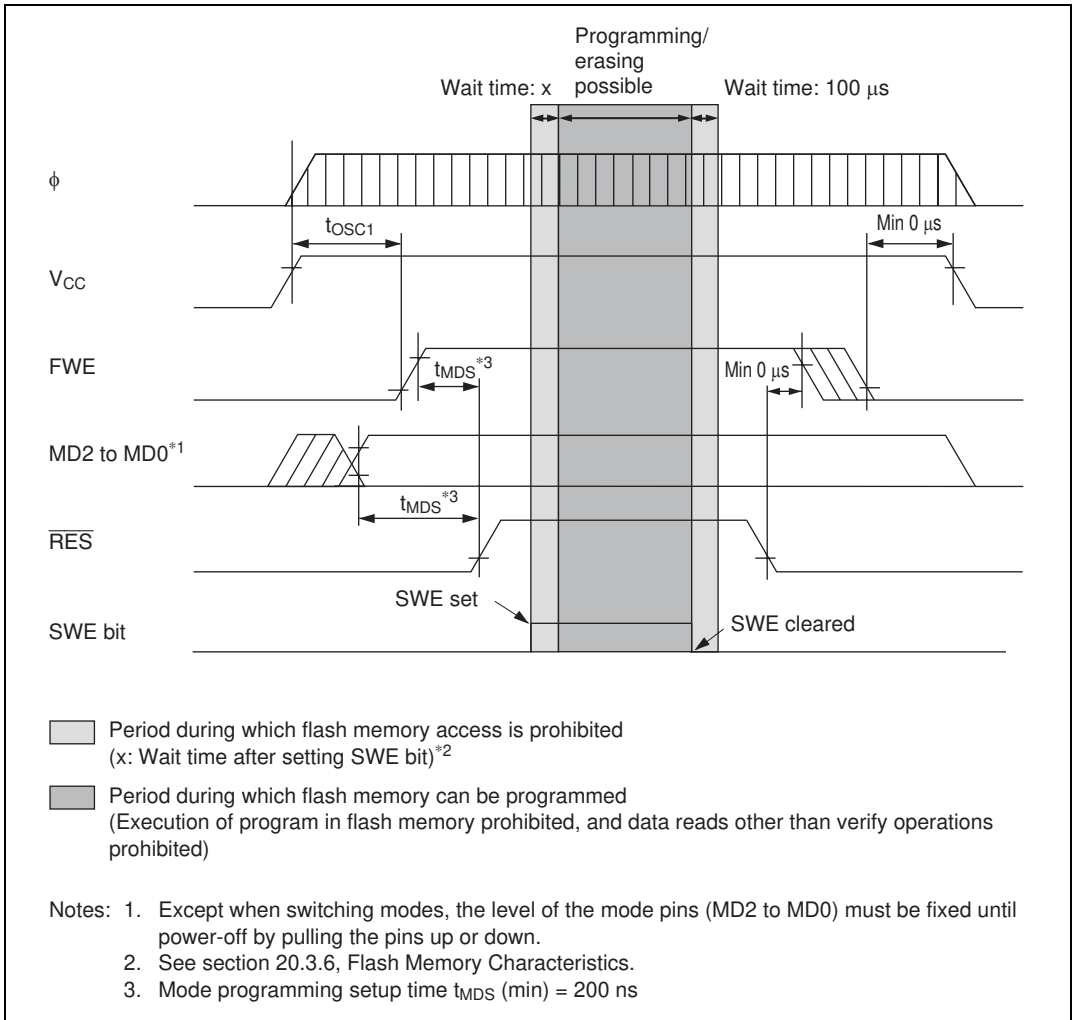

Figure 17.30 Power-On/Off Timing (Boot Mode)

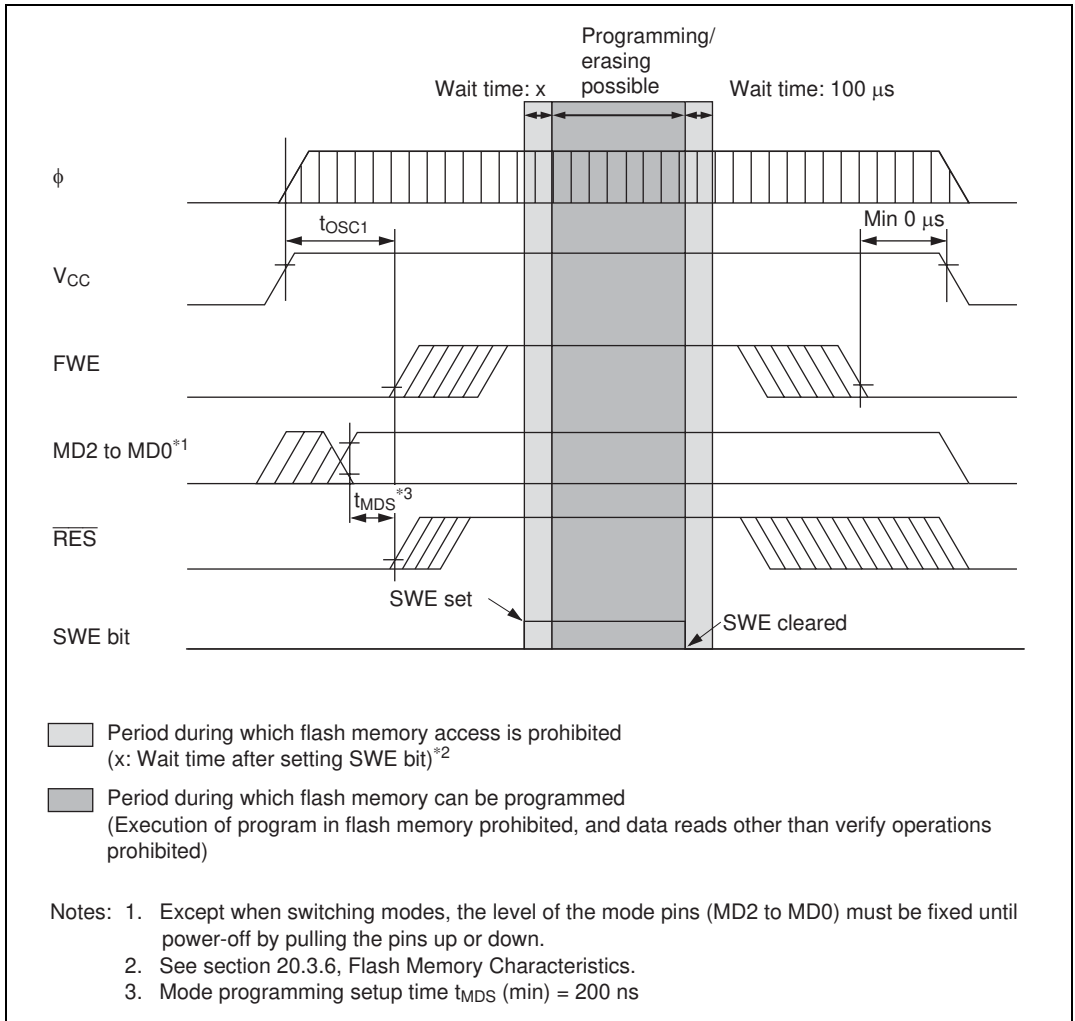

Figure 17.31 Power-On/Off Timing (User Program Mode)

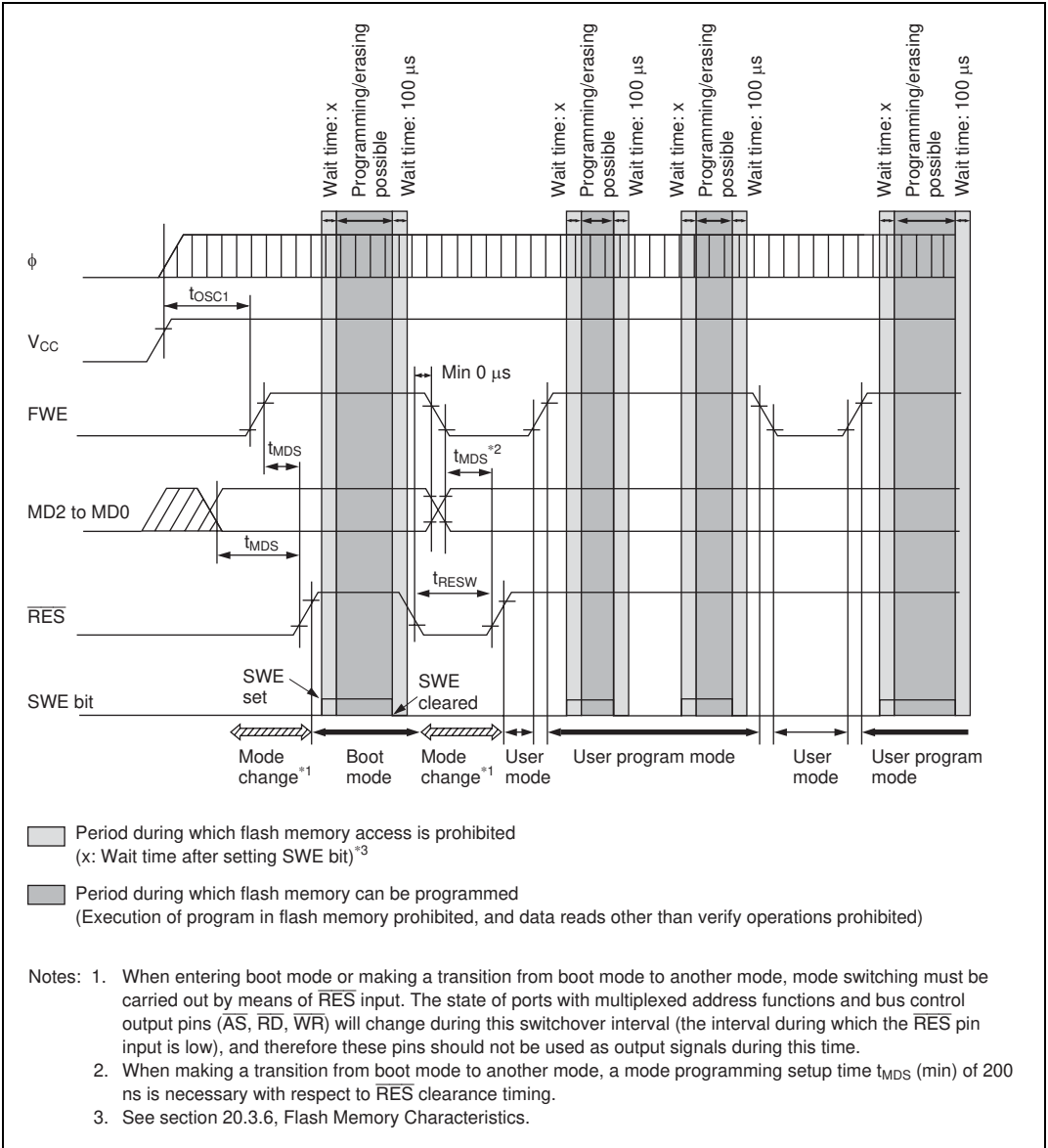

Figure 17.32 Mode Transition Timing
(Example: Boot Mode → User Mode ↔ User Program Mode)

17.13 Overview of Flash Memory (H8S/2319 F-ZTAT)

17.13.1 Features

The H8S/2319 F-ZTAT has 512 kbytes of on-chip flash memory. The features of the flash memory are summarized below.

- Four flash memory operating modes
 - Program mode
 - Erase mode
 - Program-verify mode
 - Erase-verify mode
- Programming/erase methods

The flash memory is programmed 128 bytes at a time. Erasing is performed by block erase (in single-block units). To erase the entire flash memory, the individual blocks must be erased sequentially. Block erasing can be performed as required on 4-kbyte, 32-kbyte, and 64-kbyte blocks.
- Programming/erase times

The flash memory programming time is 10.0 ms (typ.) for simultaneous 128-byte programming, equivalent to 78 μ s (typ.) per byte, and the erase time is 50 ms (typ.).
- Reprogramming capability

The flash memory can be reprogrammed a minimum of 100 times.
- On-board programming modes

There are two modes in which flash memory can be programmed/erased/verified on-board:

 - Boot mode
 - User program mode
- Automatic bit rate adjustment

With data transfer in boot mode, the bit rate of the chip can be automatically adjusted to match the transfer bit rate of the host.
- Flash memory emulation by RAM

Part of the RAM area can be overlapped onto flash memory, to emulate flash memory updates in real time.
- Protect modes

There are three protect modes, hardware, software, and error protect, which allow protected status to be designated for flash memory program/erase/verify operations.

- Programmer mode

Flash memory can be programmed/erased in programmer mode, using a PROM programmer, as well as in on-board programming mode.

17.13.2 Overview

Block Diagram

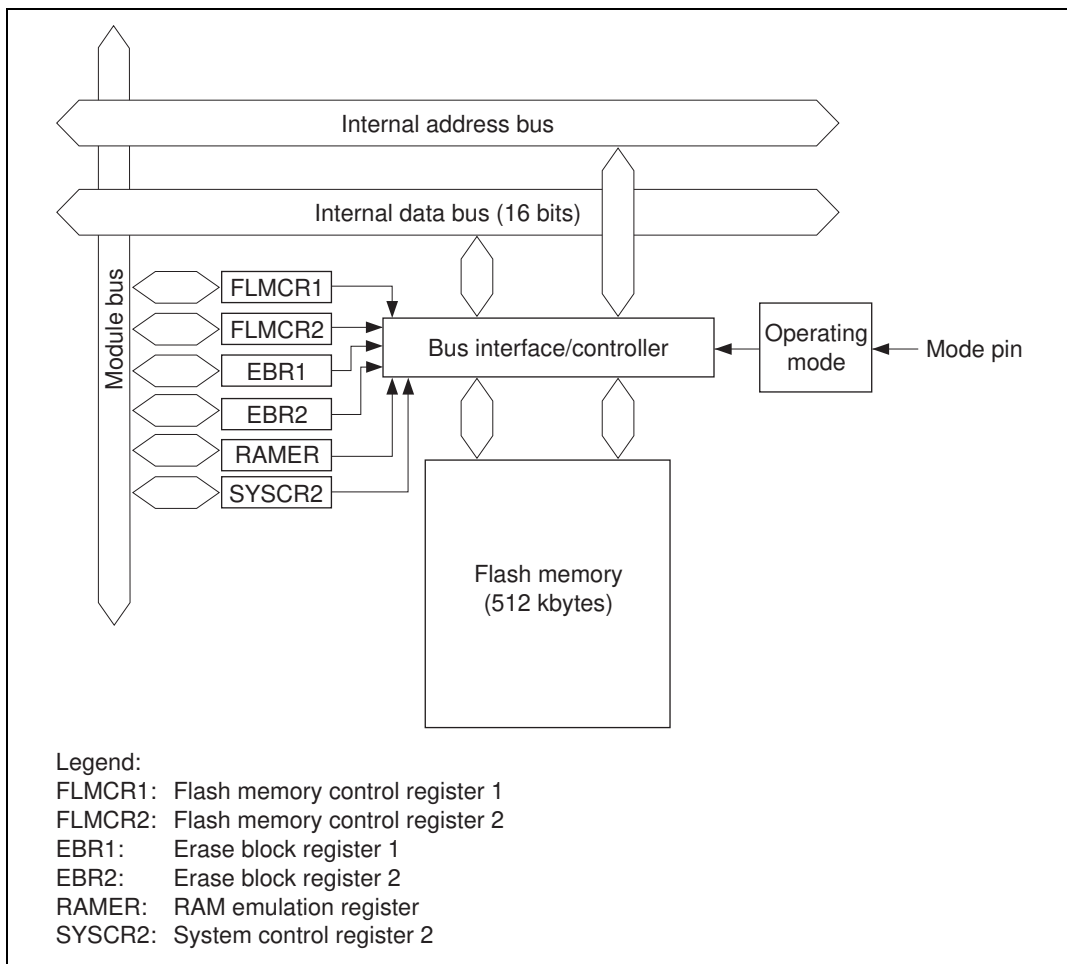

Figure 17.33 Block Diagram of Flash Memory

17.13.3 Flash Memory Operating Modes

Mode Transitions: When the mode pins are set in the reset state and a reset-start is executed, the chip enters one of the operating modes shown in figure 17.34. In user mode, flash memory can be read but not programmed or erased.

Flash memory can be programmed and erased in boot mode, user program mode, and PROM mode.

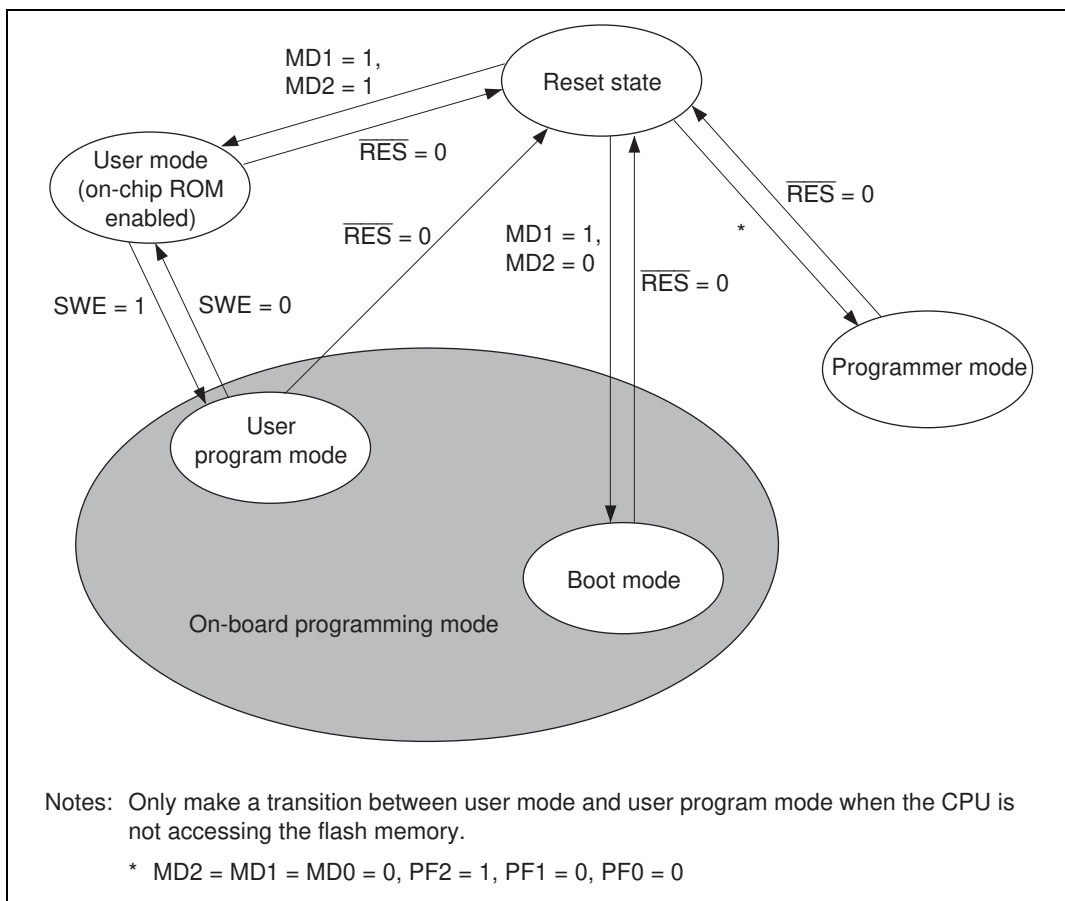

Figure 17.34 Flash Memory Mode Transitions

17.13.4 On-Board Programming Modes

- Boot mode

1. Initial state

The old program version or data remains written in the flash memory. The user should prepare the programming control program and new application program beforehand in the host.

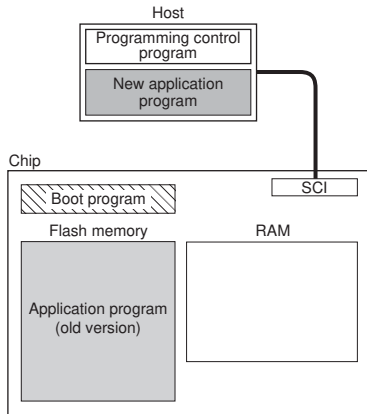

2. Programming control program transfer

When boot mode is entered, the boot program in the chip (originally incorporated in the chip) is started and the programming control program in the host is transferred to RAM via SCI communication. The boot program required for flash memory erasing is automatically transferred to the RAM boot program area.

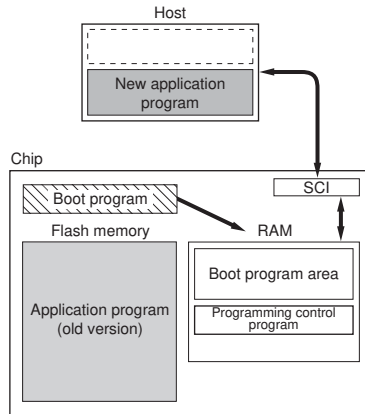

3. Flash memory initialization

The erase program in the boot program area (in RAM) is executed, and the flash memory is initialized (to H'FF'). In boot mode, entire flash memory erasure is performed, without regard to blocks.

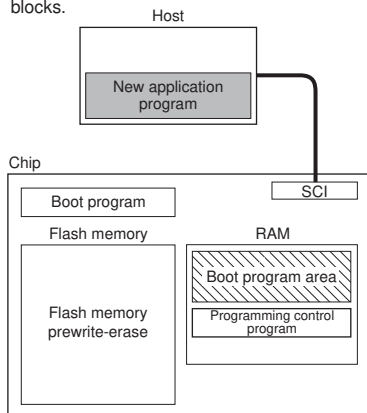

4. Writing new application program

The programming control program transferred from the host to RAM is executed, and the new application program in the host is written into the flash memory.

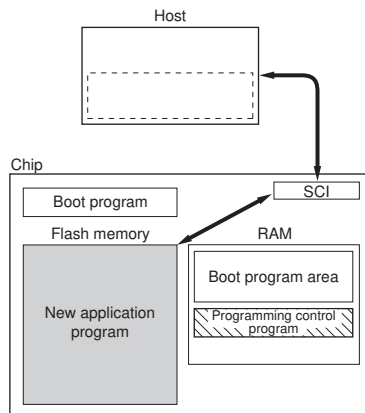

 Program execution state

Figure 17.35 Boot Mode

- User program mode

1. Initial state

(1) The program that will transfer the programming/erase control program to on-chip RAM should be written into the flash memory by the user beforehand. (2) The programming/erase control program should be prepared in the host or in the flash memory.

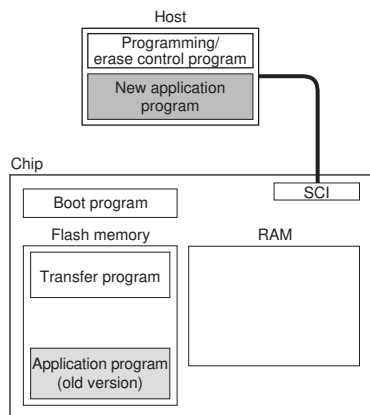

2. Programming/erase control program transfer

Executes the transfer program in the flash memory, and transfers the programming/erase control program to RAM.

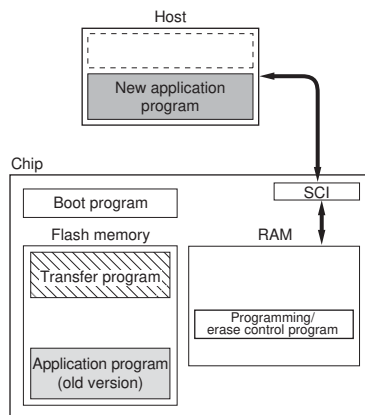

3. Flash memory initialization

The programming/erase program in RAM is executed, and the flash memory is initialized (to H'FF). Erasing can be performed in block units, but not in byte units.

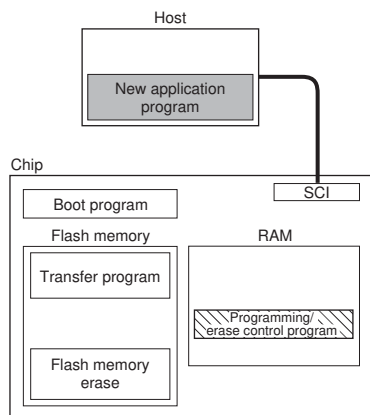

4. Writing new application program

Next, the new application program in the host is written into the erased flash memory blocks. Do not write to unerased blocks.

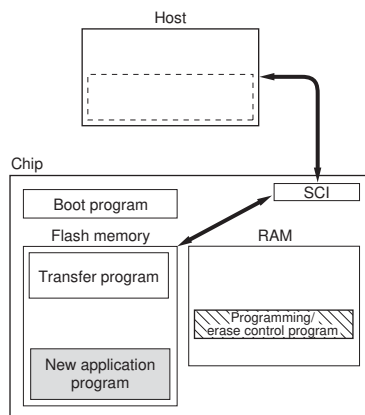

 Program execution state

Figure 17.36 User Program Mode (Example)

17.13.5 Flash Memory Emulation in RAM

Reading Overlap RAM Data in User Mode and User Program Mode: Emulation should be performed in user mode or user program mode. When the emulation block set in RAMER is accessed while the emulation function is being executed, data written in the overlap RAM is read.

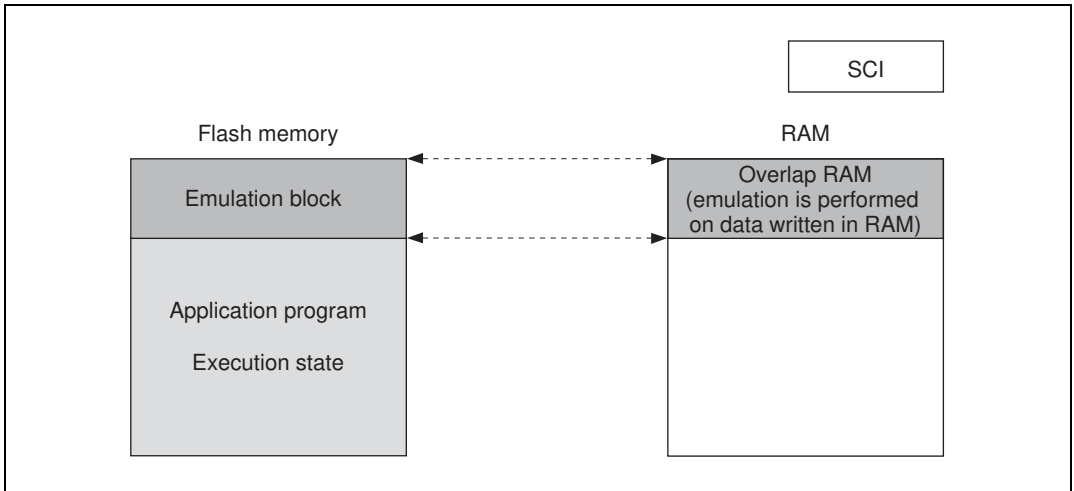

Figure 17.37 Reading Overlap RAM Data in User Mode and User Program Mode

Writing Overlap RAM Data in User Program Mode: When overlap RAM data is confirmed, the RAMS bit is cleared, RAM overlap is released, and writes should actually be performed to the flash memory.

When the programming control program is transferred to RAM, ensure that the transfer destination and the overlap RAM do not overlap, as this will cause data in the overlap RAM to be rewritten.

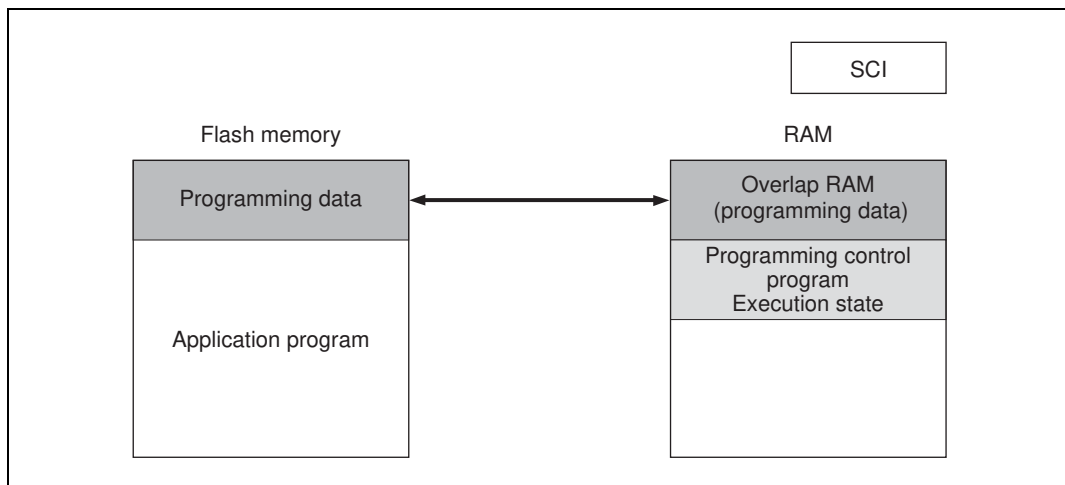

Figure 17.38 Writing Overlap RAM Data in User Program Mode

17.13.6 Differences between Boot Mode and User Program Mode

Table 17.25 Differences between Boot Mode and User Program Mode

	Boot Mode	User Program Mode
Entire memory erase	Yes	Yes
Block erase	No	Yes
Programming control program*	Program/program-verify	Erase/erase-verify/program/ program-verify/emulation

Note: * To be provided by the user, in accordance with the recommended algorithm.

17.13.7 Block Configuration

The flash memory is divided into seven 64-kbyte blocks, one 32-kbyte block, and eight 4-kbyte blocks.

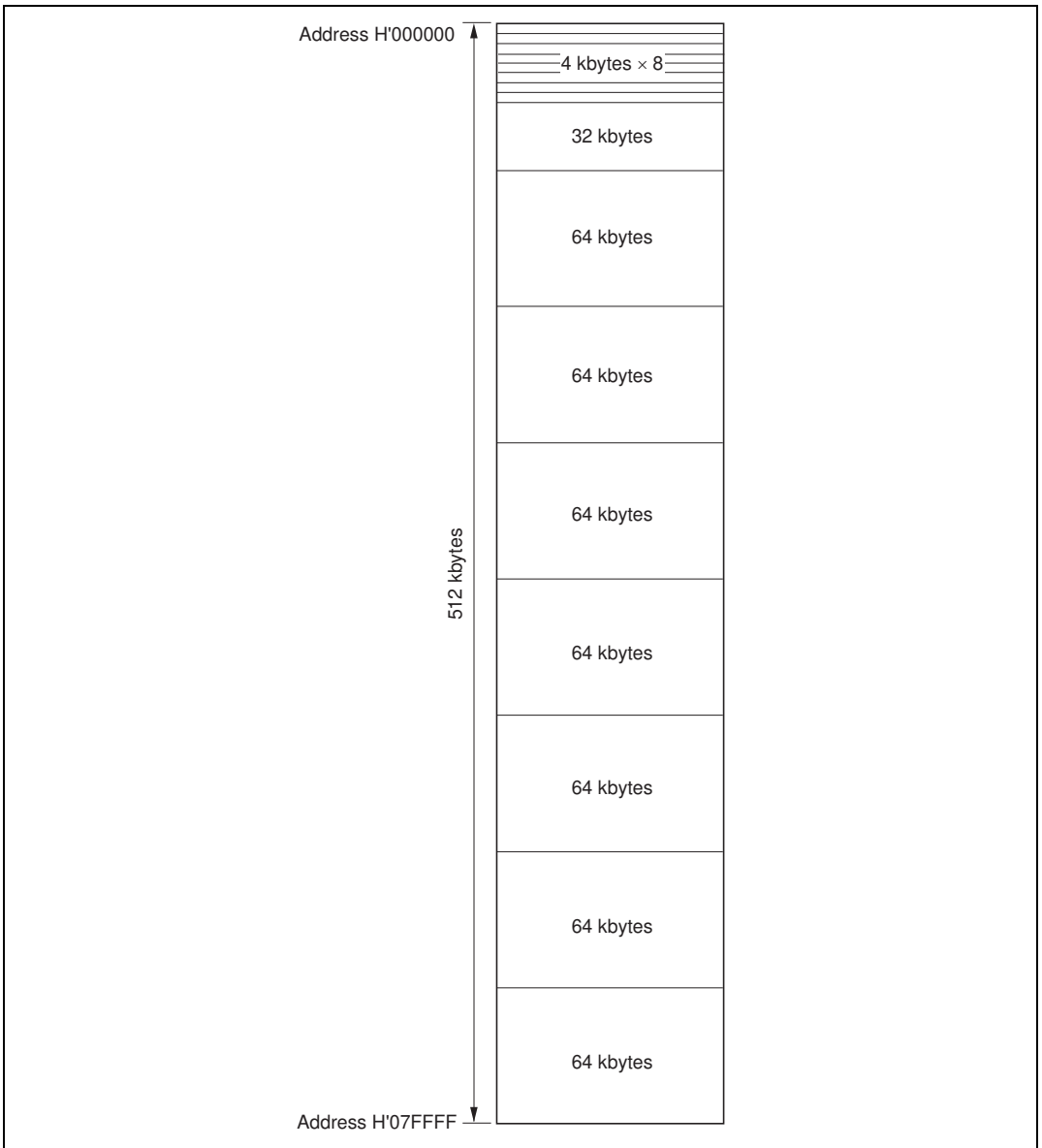

Figure 17.39 Flash Memory Block Configuration

17.13.8 Pin Configuration

The flash memory is controlled by means of the pins shown in table 17.26.

Table 17.26 Flash Memory Pins

Pin Name	Abbreviation	I/O	Function
Reset	RES	Input	Reset
Mode 2	MD2	Input	Sets MCU operating mode
Mode 1	MD1	Input	Sets MCU operating mode
Mode 0	MD0	Input	Sets MCU operating mode
Port PF2	PF2	Input	Sets MCU operating mode in programmer mode
Port PF1	PF1	Input	Sets MCU operating mode in programmer mode
Port PF0	PF0	Input	Sets MCU operating mode in programmer mode
Transmit data	TxD1	Output	Serial transmit data output
Receive data	RxD1	Input	Serial receive data input

17.13.9 Register Configuration

The registers used to control the on-chip flash memory when enabled are shown in table 17.27. In order to access the FLMCR1, FLMCR2, EBR1, and EBR2 registers, the FLSHE bit must be set to 1 in SYSCR2 (except RAMER).

Table 17.27 Flash Memory Registers

Register Name	Abbreviation	R/W	Initial Value	Address ^{*1}
Flash memory control register 1	FLMCR1 ^{*6}	R/W ^{*3}	H'80	H'FFC8 ^{*2}
Flash memory control register 2	FLMCR2 ^{*6}	R/W ^{*3}	H'00	H'FFC9 ^{*2}
Erase block register 1	EBR1 ^{*6}	R/W ^{*3}	H'00 ^{*4}	H'FFCA ^{*2}
Erase block register 2	EBR2 ^{*6}	R/W ^{*3}	H'00 ^{*5}	H'FFCB ^{*2}
System control register 2	SYSCR2 ^{*7}	R/W	H'00	H'FF42
RAM emulation register	RAMER	R/W	H'00	H'FEDB

Notes: 1. Lower 16 bits of the address.

2. Flash memory. Registers selection is performed by the FLSHE bit in system control register 2 (SYSCR2).
3. In modes in which the on-chip flash memory is disabled, a read will return H'00, and writes are invalid.
4. If a high level is input and the SWE bit in FLMCR1 is not set, these registers are initialized to H'00.
5. Bits 3 to 0 are initialized to 0 when the SWE1 bit in FLMCR1 is not set, and bits 7 to 4 are initialized to 0 when the SWE2 bit in FLMCR2 is not set.
6. FLMCR1, FLMCR2, EBR1, and EBR2 are 8-bit registers. Only byte accesses are valid for these registers, the access requiring 2 states.
7. The SYSCR2 register can only be used in the F-ZTAT version. In the mask ROM version this register will return an undefined value if read, and cannot be modified.

17.14 Register Descriptions

17.14.1 Flash Memory Control Register 1 (FLMCR1)

Bit	:	7	6	5	4	3	2	1	0
		FWE1	SWE1	ESU1	PSU1	EV1	PV1	E1	P1
Initial value	:	1	0	0	0	0	0	0	0
R/W	:	R	R/W	R/W	R/W	R/W	R/W	R/W	R/W

FLMCR1 is an 8-bit register used for flash memory operating mode control. Program-verify mode or erase-verify mode for addresses H'000000 to H'03FFFF is entered by setting SWE1 to 1 then setting the EV1 or PV1 bit. Program mode for addresses H'000000 to H'03FFFF is entered by setting SWE1 to 1 then setting the PSU1 bit, and finally setting the P1 bit. Erase mode for addresses H'000000 to H'03FFFF is entered by setting SWE1 to 1 then setting the ESU1 bit, and finally setting the E1 bit. FLMCR1 is initialized to H'80 by a reset, and in hardware standby mode and software standby mode. When on-chip flash memory is disabled, a read will return H'00, and writes are invalid.

Writes to bits ESU1, PSU1, EV1, and PV1 only when SWE1 = 1; writes to the E1 bit only when SWE1 = 1, and ESU1 = 1; and writes to the P1 bit only when SWE1 = 1, and PSU1 = 1.

Bit 7—Flash Write Enable Bit (FWE): Sets hardware protection against flash memory programming/erasing. This bit cannot be modified and is always read as 1 in this model.

Bit 6—Software Write Enable Bit 1 (SWE1): Enables or disables flash memory programming and erasing for addresses H'000000 to H'03FFFF. This bit should be set when setting FLMCR1 bits 5 to 0, EBR1 bits 7 to 0, and EBR2 bits 3 to 0.

When SWE1 = 1, the flash memory can only be read in program-verify or erase-verify mode.

Bit 6

SWE1	Description
0	Writes disabled (Initial value)
1	Writes enabled

Bit 5—Erase Setup Bit 1 (ESU1): Prepares for a transition to erase mode for addresses H'000000 to H'03FFFF. Do not set the SWE1, PSU1, EV1, PV1, E1, or P1 bit at the same time.

Bit 5 ESU1	Description	
0	Erase setup cleared	(Initial value)
1	Erase setup [Setting condition] When SWE1 = 1	

Bit 4—Program Setup Bit 1 (PSU1): Prepares for a transition to program mode for addresses H'000000 to H'03FFFF. Do not set the SWE1, ESU1, EV1, PV1, E1, or P1 bit at the same time.

Bit 4 PSU1	Description	
0	Program setup cleared	(Initial value)
1	Program setup [Setting condition] When SWE1 = 1	

Bit 3—Erase-Verify 1 (EV1): Selects erase-verify mode transition or clearing for addresses H'000000 to H'03FFFF. Do not set the SWE1, ESU1, PSU1, PV1, E1, or P1 bit at the same time.

Bit 3 EV1	Description	
0	Erase-verify mode cleared	(Initial value)
1	Transition to erase-verify mode [Setting condition] When SWE1 = 1	

Bit 2—Program-Verify 1 (PV1): Selects program-verify mode transition or clearing for addresses H'000000 to H'03FFFF. Do not set the SWE1, ESU1, PSU1, EV1, E1, or P1 bit at the same time.

Bit 2

PV1	Description
0	Program-verify mode cleared (Initial value)
1	Transition to program-verify mode [Setting condition] When SWE1 = 1

Bit 1—Erase 1 (E1): Selects erase mode transition or clearing for addresses H'000000 to H'03FFFF. Do not set the SWE1, ESU1, PSU1, EV1, PV1, or P1 bit at the same time.

Bit 1

E1	Description
0	Erase mode cleared (Initial value)
1	Transition to erase mode [Setting condition] When SWE1 = 1, and ESU1 = 1

Bit 0—Program 1 (P1): Selects program mode transition or clearing for addresses H'000000 to H'03FFFF. Do not set the SWE1, PSU1, ESU1, EV1, PV1, or E1 bit at the same time.

Bit 0

P1	Description
0	Program mode cleared (Initial value)
1	Transition to program mode [Setting condition] When SWE1 = 1, and PSU1 = 1

17.14.2 Flash Memory Control Register 2 (FLMCR2)

Bit	:	7	6	5	4	3	2	1	0
		FLER	SWE2	ESU2	PSU2	EV2	PV2	E2	P2
Initial value	:	0	0	0	0	0	0	0	0
R/W	:	R	R/W	R/W	R/W	R/W	R/W	R/W	R/W

FLMCR2 is an 8-bit register used for flash memory operating mode control. Program-verify mode or erase-verify mode for addresses H'040000 to H'07FFFF is entered by setting SWE2 to 1 then setting the EV2 or PV2 bit. Program mode for addresses H'040000 to H'07FFFF is entered by setting SWE2 to 1 then setting the PSU2 bit, and finally setting the P2 bit. Erase mode for addresses H'040000 to H'07FFFF is entered by setting SWE2 to 1 then setting the ESU2 bit, and finally setting the E2 bit. FLMCR2 is initialized to H'00 by a reset, and in hardware standby mode and software standby mode. When on-chip flash memory is disabled, a read will return H'00, and writes are invalid.

Writes to bits ESU2, PSU2, EV2, and PV2 only when SWE2 = 1; writes to the E2 bit only when SWE2 = 1, and ESU2 = 1; and writes to the P2 bit only when SWE2 = 1, and PSU2 = 1.

Bit 7—Flash Memory Error (FLER): Indicates that an error has occurred during an operation on flash memory (programming or erasing). When FLER is set to 1, flash memory goes to the error-protection state.

Bit 7

FLER	Description
0	Flash memory is operating normally (Initial value) Flash memory program/erase protection (error protection) is disabled [Clearing condition] Reset or hardware standby mode
1	An error has occurred during flash memory programming/erasing Flash memory program/erase protection (error protection) is enabled [Setting condition] See section 17.17.3, Error Protection

Bit 6—Software Write Enable Bit 2 (SWE2): Enables or disables flash memory programming and erasing for addresses H'040000 to H'07FFFF. This bit should be set when setting FLMCR2 bits 5 to 0, and EBR2 bits 7 to 4.

When SWE2 = 1, the flash memory can only be read in program-verify or erase-verify mode.

Bit 6

SWE2	Description
0	Writes disabled (Initial value)
1	Writes enabled

Bit 5—Erase Setup Bit 2 (ESU2): Prepares for a transition to erase mode for addresses H'040000 to H'07FFFF. Do not set the SWE2, PSU2, EV2, PV2, E2, or P2 bit at the same time.

Bit 5

ESU2	Description
0	Erase setup cleared (Initial value)
1	Erase setup [Setting condition] When SWE2 = 1

Bit 4—Program Setup Bit 2 (PSU2): Prepares for a transition to program mode for addresses H'040000 to H'07FFFF. Do not set the SWE2, ESU2, EV2, PV2, E2, or P2 bit at the same time.

Bit 4

PSU2	Description
0	Program setup cleared (Initial value)
1	Program setup [Setting condition] When SWE2 = 1

Bit 3—Erase-Verify 2 (EV2): Selects erase-verify mode transition or clearing for addresses H'040000 to H'07FFFF. Do not set the SWE2, ESU2, PSU2, PV2, E2, or P2 bit at the same time.

Bit 3

EV2	Description
0	Erase-verify mode cleared (Initial value)
1	Transition to erase-verify mode [Setting condition] When SWE2 = 1

Bit 2—Program-Verify 2 (PV2): Selects program-verify mode transition or clearing for addresses H'040000 to H'07FFFF. Do not set the SWE2, ESU2, PSU2, EV2, E2, or P2 bit at the same time.

Bit 2

PV2	Description
0	Program-verify mode cleared (Initial value)
1	Transition to program-verify mode [Setting condition] When SWE2 = 1

Bit 1—Erase 2 (E2): Selects erase mode transition or clearing for addresses H'040000 to H'07FFFF. Do not set the SWE2, ESU2, PSU2, EV2, PV2, or P2 bit at the same time.

Bit 1

E2	Description
0	Erase mode cleared (Initial value)
1	Transition to erase mode [Setting condition] When SWE2 = 1, and ESU2 = 1

Bit 0—Program 2 (P2): Selects program mode transition or clearing for H'040000 to H'07FFFF. Do not set the SWE2, PSU2, ESU2, EV2, PV2, or E2 bit at the same time.

Bit 0

P2	Description
0	Program mode cleared (Initial value)
1	Transition to program mode [Setting condition] When SWE2 = 1, and PSU2 = 1

17.14.3 Erase Block Register 1 (EBR1)

Bit	:	7	6	5	4	3	2	1	0
EBR1		EB7	EB6	EB5	EB4	EB3	EB2	EB1	EB0
Initial value	:	0	0	0	0	0	0	0	0
R/W	:	R/W	R/W	R/W	R/W	R/W	R/W	R/W	R/W

EBR1 is an 8-bit register that specifies the flash memory erase area block by block. EBR1 is initialized to H'00 by a reset, in hardware standby mode and software standby mode, and the SWE1 bit in FLMCR1 is not set. When a bit in EBR1 is set, the corresponding block can be erased. Other blocks are erase-protected. Set only one bit in EBR1 and EBR2 together (setting more than one bit will automatically clear all EBR1 and EBR2 bits to 0). When on-chip flash memory is disabled, a read will return H'00 and writes are invalid.

The flash memory block configuration is shown in table 17.28.

17.14.4 Erase Block Register 2 (EBR2)

Bit	:	7	6	5	4	3	2	1	0
EBR2		EB15	EB14	EB13	EB12	EB11	EB10	EB9	EB8
Initial value :		0	0	0	0	0	0	0	0
R/W	:	R/W	R/W	R/W	R/W	R/W	R/W	R/W	R/W

EBR2 is an 8-bit register that specifies the flash memory erase area block by block. EBR2 is initialized to H'00 by a reset, in hardware standby mode and software standby mode, and when the SWE1 bit in FLMCR1 is not set. When a bit in EBR2 is set, the corresponding block can be erased. Other blocks are erase-protected. Set only one bit in EBR2 and EBR1 together (setting more than one bit will automatically clear all EBR1 and EBR2 bits to 0). When on-chip flash memory is disabled, a read will return H'00, and writes are invalid.

The flash memory block configuration is shown in table 17.28.

Table 17.28 Flash Memory Erase Blocks

Block (Size)	Address
EB0 (4 kbytes)	H'000000 to H'000FFF
EB1 (4 kbytes)	H'001000 to H'001FFF
EB2 (4 kbytes)	H'002000 to H'002FFF
EB3 (4 kbytes)	H'003000 to H'003FFF
EB4 (4 kbytes)	H'004000 to H'004FFF
EB5 (4 kbytes)	H'005000 to H'005FFF
EB6 (4 kbytes)	H'006000 to H'006FFF
EB7 (4 kbytes)	H'007000 to H'007FFF
EB8 (32 kbytes)	H'008000 to H'00FFFF
EB9 (64 kbytes)	H'010000 to H'01FFFF
EB10 (64 kbytes)	H'020000 to H'02FFFF
EB11 (64 kbytes)	H'030000 to H'03FFFF
EB12 (64 kbytes)	H'040000 to H'04FFFF
EB13 (64 kbytes)	H'050000 to H'05FFFF
EB14 (64 kbytes)	H'060000 to H'06FFFF
EB15 (64 kbytes)	H'070000 to H'07FFFF

17.14.5 System Control Register 2 (SYSCR2)

Bit	:	7	6	5	4	3	2	1	0
		—	—	—	—	FLSHE	—	—	—
Initial value	:	0	0	0	0	0	0	0	0
R/W	:	—	—	—	—	R/W	—	—	R/W

SYSCR2 is an 8-bit readable/writable register that performs on-chip flash memory control.

SYSCR2 is initialized to H'00 by a reset and in hardware standby mode.

SYSCR2 can only be used in the F-ZTAT version. In the mask ROM version this register will return an undefined value if read, and cannot be modified.

Bits 7 to 4—Reserved: These bits cannot be modified and are always read as 0.

Bit 3—Flash Memory Control Register Enable (FLSHE): Controls CPU access to the flash memory control registers (FLMCR1, FLMCR2, EBR1, and EBR2). Writing 1 to the FLSHE bit enables the flash memory control registers to be read and written to. Clearing FLSHE to 0 designates these registers as unselected (the register contents are retained).

Bit 3

FLSHE	Description
0	Flash control registers are not selected for addresses H'FFFC8 to H'FFFCB (Initial value)
1	Flash control registers are selected for addresses H'FFFC8 to H'FFFCB

Bits 2 and 1—Reserved: These bits cannot be modified and are always read as 0.

Bit 0—Reserved: Only 0 should be written.

17.14.6 RAM Emulation Register (RAMER)

Bit	:	7	6	5	4	3	2	1	0
		—	—	—	—	RAMS	RAM2	RAM1	RAM0
Initial value	:	0	0	0	0	0	0	0	0
R/W	:	—	—	—	—	R/W	R/W	R/W	R/W

RAMER specifies the area of flash memory to be overlapped with part of RAM when emulating real-time flash memory programming. RAMER is initialized to H'00 by a reset and in hardware

standby mode. It is not initialized in software standby mode. RAMER settings should be made in user mode or user program mode.

Flash memory area divisions are shown in table 17.29. To ensure correct operation of the emulation function, the ROM for which RAM emulation is performed should not be accessed immediately after this register has been modified. Normal execution of an access immediately after register modification is not guaranteed.

Bits 7 to 4—Reserved: These bits cannot be modified and are always read as 0.

Bit 3—RAM Select (RAMS): Specifies selection or non-selection of flash memory emulation in RAM. When RAMS = 1, all flash memory blocks are program/erase-protected.

Bit 3 RAMS	Description	
0	Emulation not selected Program/erase-protection of all flash memory blocks is disabled	(Initial value)
1	Emulation selected Program/erase-protection of all flash memory blocks is enabled	

Bits 2 to 0—Flash Memory Area Selection (RAM2 to RAM0): These bits are used together with bit 3 to select the flash memory area to be overlapped with RAM (see table 17.29).

Table 17.29 Flash Memory Area Divisions

RAM Area	Block Name	RAMS	RAM2	RAM1	RAM0
H'FFDC00 to H'FFEBFF	RAM area, 4 kbytes	0	×	×	×
H'000000 to H'000FFF	EB0 (4 kbytes)	1	0	0	0
H'001000 to H'001FFF	EB1 (4 kbytes)	1	0	0	1
H'002000 to H'002FFF	EB2 (4 kbytes)	1	0	1	0
H'003000 to H'003FFF	EB3 (4 kbytes)	1	0	1	1
H'004000 to H'004FFF	EB4 (4 kbytes)	1	1	0	0
H'005000 to H'005FFF	EB5 (4 kbytes)	1	1	0	1
H'006000 to H'006FFF	EB6 (4 kbytes)	1	1	1	0
H'007000 to H'007FFF	EB7 (4 kbytes)	1	1	1	1

×: Don't care

17.15 On-Board Programming Modes

When pins are set to on-board programming mode, program/erase/verify operations can be performed on the on-chip flash memory. There are two on-board programming modes: boot mode and user program mode. The pin settings for transition to each of these modes are shown in table 17.30. For a diagram of the transitions to the various flash memory modes, see figure 17.34.

Table 17.30 Setting On-Board Programming Modes

MCU Mode	Modes	Pins		
	CPU Operating Mode	MD2	MD1	MD0
Boot mode	Advanced expanded mode with on-chip ROM enabled	0	1	0
	Advanced single-chip mode			1
User program mode*	Advanced expanded mode with on-chip ROM enabled	1	1	0
	Advanced single-chip mode			1

Note: * Normally, user mode should be used. Set the SWE bit to 1 to make a transition to user program mode before performing a program/erase/verify operation.

17.15.1 Boot Mode

When boot mode is used, the flash memory programming control program must be prepared in the host beforehand. The channel 1 SCI to be used is set to asynchronous mode.

When a reset-start is executed after the H8S/2319 F-ZTAT chip's pins have been set to boot mode, the boot program built into the chip is started and the programming control program prepared in the host is serially transmitted to the chip via the SCI. In the chip, the programming control program received via the SCI is written into the programming control program area in on-chip RAM. After the transfer is completed, control branches to the start address of the programming control program area and the programming control program execution state is entered (flash memory programming is performed).

The transferred programming control program must therefore include coding that follows the programming algorithm given later.

The system configuration in boot mode is shown in figure 17.40, and the boot program mode execution procedure in figure 17.41.

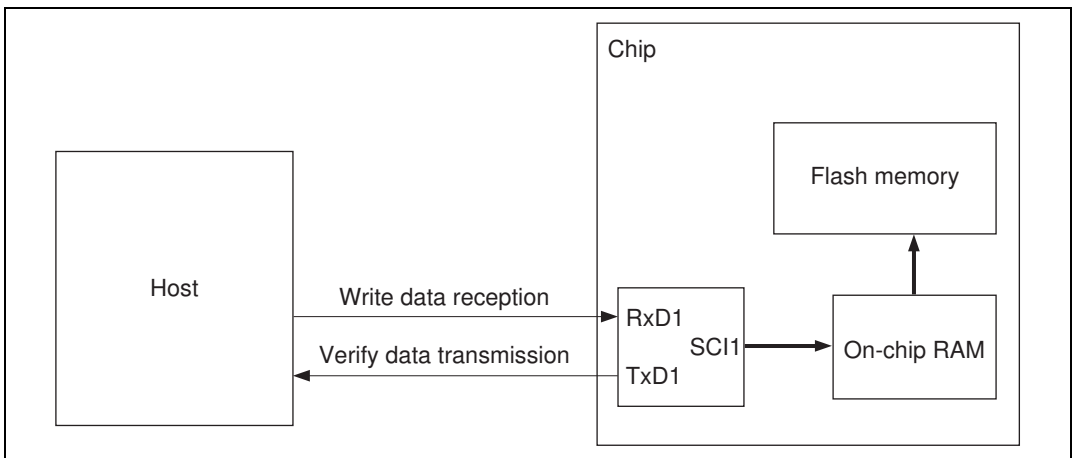

Figure 17.40 System Configuration in Boot Mode

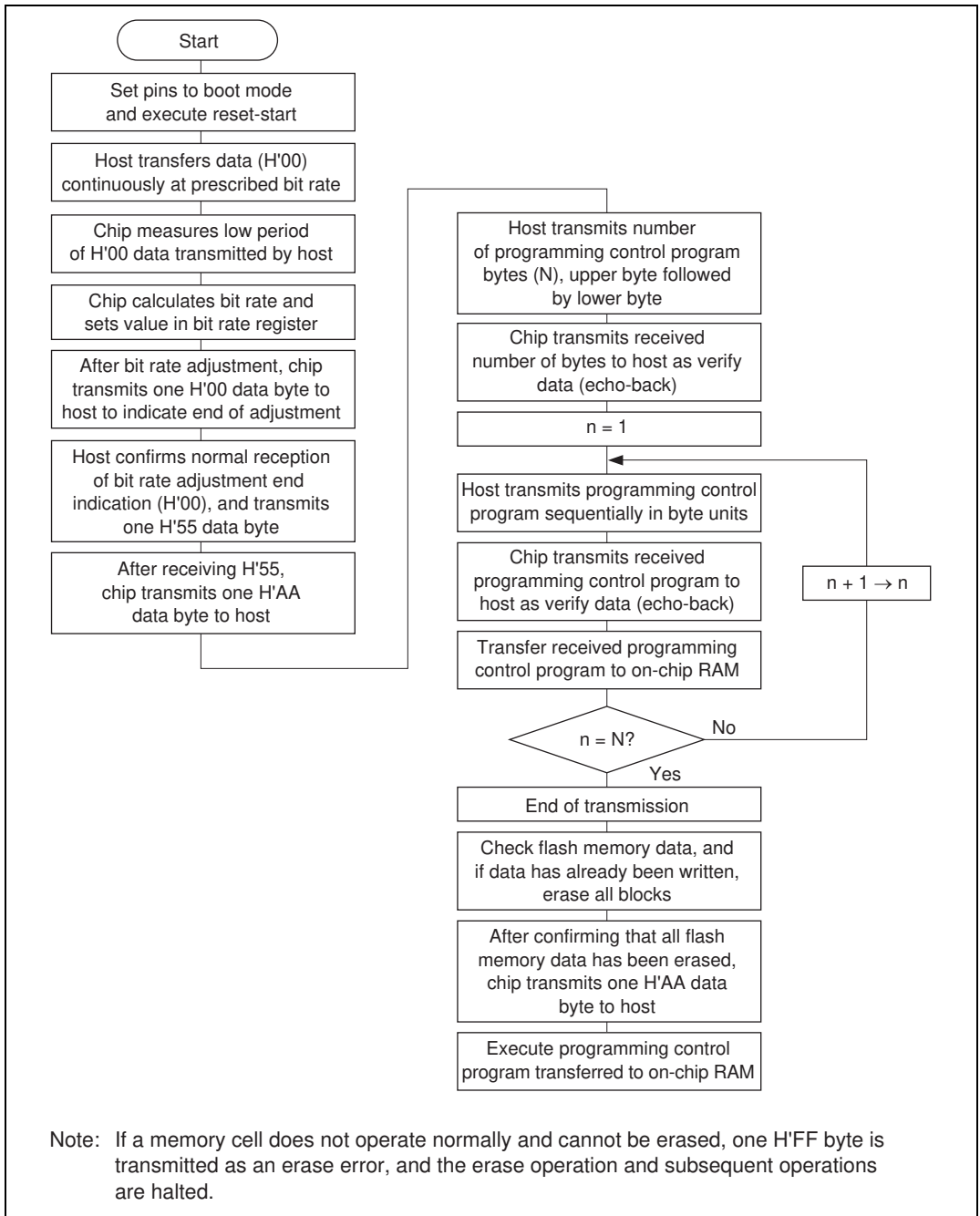

Figure 17.41 Boot Mode Execution Procedure

Automatic SCI Bit Rate Adjustment: When boot mode is initiated, the H8S/2319 F-ZTAT chip measures the low period of the asynchronous SCI communication data (H'00) transmitted continuously from the host. The SCI transmit/receive format should be set as follows: 8-bit data, 1 stop bit, no parity. The chip calculates the bit rate of the transmission from the host from the measured low period, and transmits one H'00 byte to the host to indicate the end of bit rate adjustment. The host should confirm that this adjustment end indication (H'00) has been received normally, and transmit one H'55 byte to the chip. If reception cannot be performed normally, initiate boot mode again (reset), and repeat the above operations. Depending on the host's transmission bit rate and the chip's system clock frequency, there will be a discrepancy between the bit rates of the host and the chip. To ensure correct SCI operation, the host's transfer bit rate should be set to 9,600 or 19,200 bps.

Table 17.31 shows typical host transfer bit rates and system clock frequencies for which automatic adjustment of the MCU's bit rate is possible. The boot program should be executed within this system clock range.

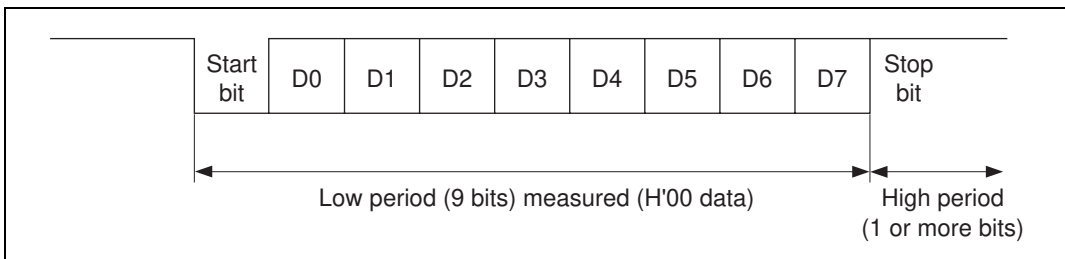

Figure 17.42 Automatic SCI Bit Rate Adjustment

Table 17.31 System Clock Frequencies for Which Automatic Adjustment of H8S/2319 F-ZTAT Bit Rate Is Possible

Host Bit Rate	System Clock Frequency for Which Automatic Adjustment of H8S/2319 F-ZTAT Bit Rate Is Possible
19,200 bps	16 MHz to 25 MHz
9,600 bps	8 MHz to 25 MHz

On-Chip RAM Area Divisions in Boot Mode: In boot mode, the 2-kbyte area from H'FFDC00 to H'FFE3FF is reserved for use by the boot program, as shown in figure 17.43. The area to which the programming control program is transferred is H'FFE400 to H'FFFBFF. The boot program area can be used when the programming control program transferred into RAM enters the execution state. A stack area should be set up as required.

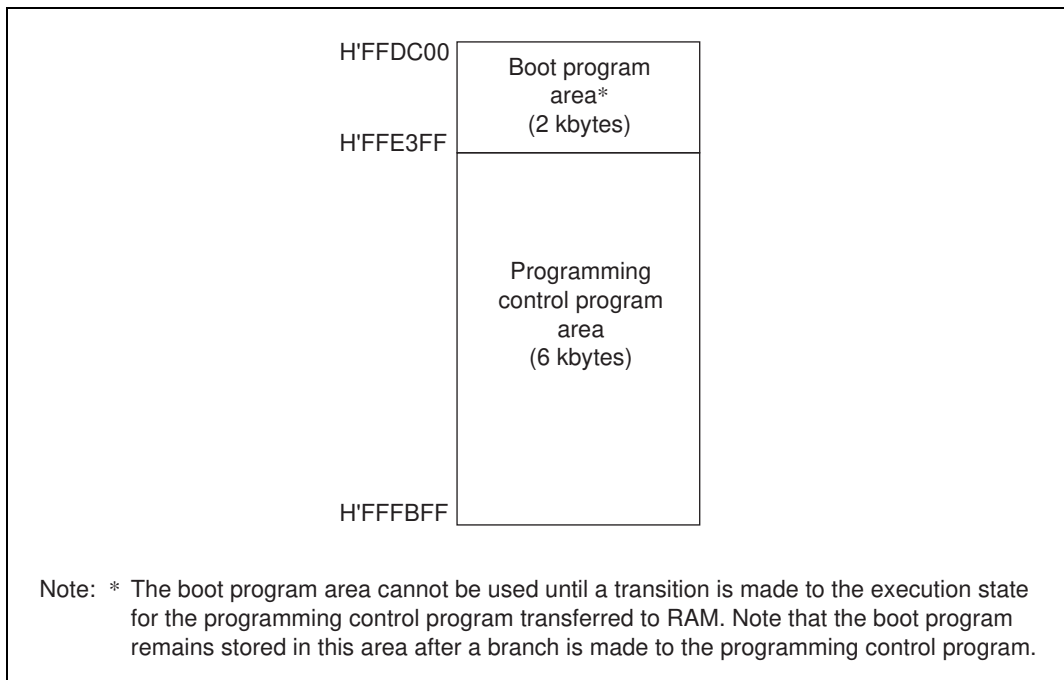

Figure 17.43 RAM Areas in Boot Mode

Notes on Use of Boot Mode

- When the chip comes out of reset in boot mode, it measures the low-level period of the input at the SCI's RxD1 pin. The reset should end with RxD1 high. After the reset ends, it takes approximately 100 states before the chip is ready to measure the low-level period of the RxD1 pin.
- In boot mode, if any data has been programmed into the flash memory (if all data is not 1), all flash memory blocks are erased. Boot mode is for use when user program mode is unavailable, such as the first time on-board programming is performed, or if the program activated in user program mode is accidentally erased.
- Interrupts cannot be used while the flash memory is being programmed or erased.

- The RxD1 and TxD1 pins should be pulled up on the board.
- Before branching to the programming control program (RAM area H'FFE400 to H'FFFBFF), the chip terminates transmit and receive operations by the on-chip SCI (channel 1) (by clearing the RE and TE bits in SCR to 0), but the adjusted bit rate value remains set in BRR. The transmit data output pin, TxD1, goes to the high-level output state (P31DDR = 1, P31DR = 1).

The contents of the CPU's internal general registers are undefined at this time, so these registers must be initialized immediately after branching to the programming control program. In particular, since the stack pointer (SP) is used implicitly in subroutine calls, etc., a stack area must be specified for use by the programming control program.

Initial settings must also be made for the other on-chip registers.

- Boot mode can be entered by making the pin settings shown in table 17.30 and executing a reset-start.

Boot mode can be cleared by driving the reset pin low, waiting at least 20 states, then setting the mode pins, and executing reset release^{*1}. Boot mode can also be cleared by a WDT overflow reset.

Do not change the mode pin input levels in boot mode.

- If the mode pin input levels are changed (for example, from low to high) during a reset, the state of ports with multiplexed address functions and bus control output pins (AS, RD, HWR) will change according to the change in the microcomputer's operating mode^{*2}.

Therefore, care must be taken to make pin settings to prevent these pins from becoming output signal pins during a reset, or to prevent collision with signals outside the microcomputer.

- Notes: 1. Mode pins input must satisfy the mode programming setup time ($t_{MDS} = 200$ ns) with respect to the reset release timing.
2. See section 8, I/O Ports.

17.15.2 User Program Mode

When set to user program mode, the chip can program and erase its flash memory by executing a user program/erase control program. Therefore, on-board reprogramming of the on-chip flash memory can be carried out by providing an on-board means to supply programming data, and storing a program/erase control program in part of the program area if necessary.

To select user program mode, select a mode that enables the on-chip flash memory (mode 6 or 7). In this mode, on-chip supporting modules other than flash memory operate as they normally would in modes 6 and 7.

While the SWE1 bit is set to 1 to perform programming or erasing for the addresses H'000000 to H'03FFFF, this address area cannot be read. While the SWE2 bit is set to 1 to perform programming or erasing for the addresses H'040000 to H'07FFFF, this address area cannot be read. The control program that performs programming and erasing should be run in on-chip RAM or flash memory except for the above address areas. When the program is located in external memory, an instruction for programming the flash memory and the following instruction should be located in on-chip RAM.

Figure 17.44 shows the procedure for executing the program/erase control program when transferred to on-chip RAM.

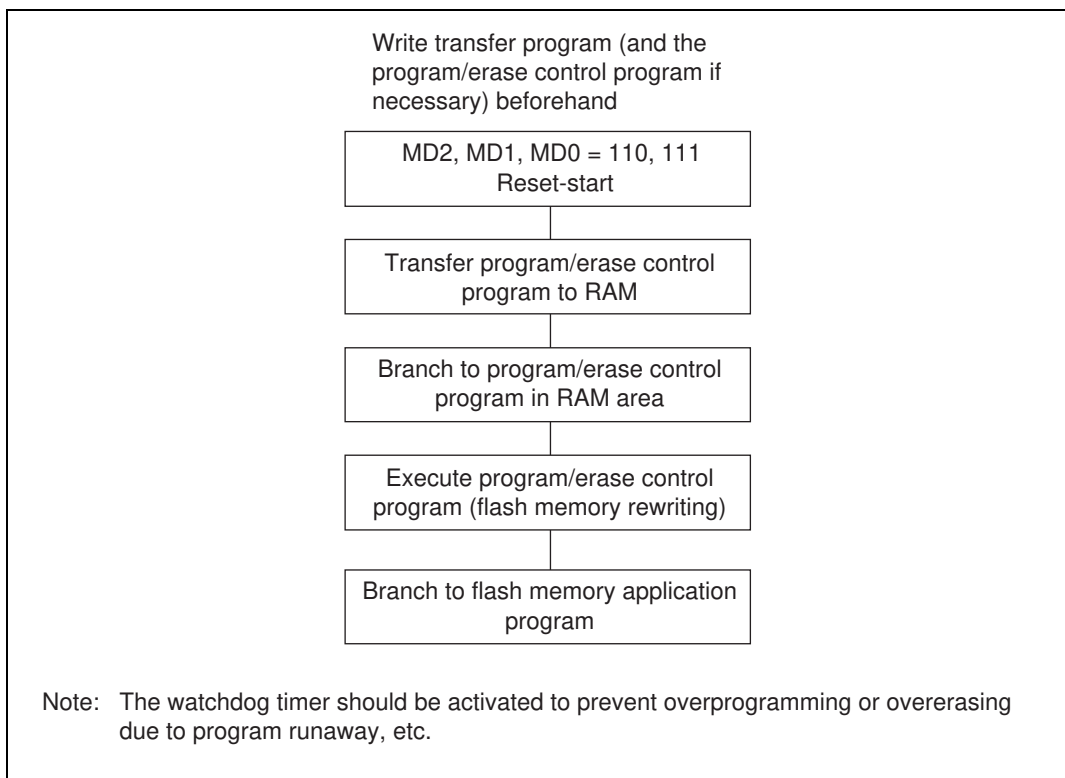

Figure 17.44 User Program Mode Execution Procedure

17.16 Programming/Erasing Flash Memory

In the on-board programming modes, flash memory programming and erasing is performed by software, using the CPU. There are four flash memory operating modes: program mode, erase mode, program-verify mode, and erase-verify mode. Transition to these modes can be made for addresses H'000000 to H'03FFFF by setting the PSU1, ESU1, P1, E1, PV1, and EV1 bits in FLMCR1, and for addresses H'040000 to H'07FFFF by setting the PSU2, ESU2, P2, E2, PV2, and EV2 bits in FLMCR2.

The flash memory cannot be read while being programmed or erased. Therefore, the program that controls flash memory programming/erasing (the programming control program) should be located and executed in on-chip RAM, external memory, or flash memory except for the above address areas. When the program is located in external memory, an instruction for programming the flash memory and the following instruction should be located in on-chip RAM. The DTC should not be activated before or after the instruction for programming the flash memory is executed.

- Notes:
1. Operation is not guaranteed if setting/resetting of the SWE1, ESU1, PSU1, EV1, PV1, E1, and P1 bits in FLMCR1 or setting/resetting of the SWE2, ESU2, PSU2, EV2, PV2, E2, and P2 bits in FLMCR2 is executed by a program in flash memory.
 2. Perform programming in the erased state. Do not perform additional programming on previously programmed addresses.
 3. Do not program addresses H'000000 to H'03FFFF and H'040000 to H'07FFFF simultaneously. Operation is not guaranteed when programming is performed simultaneously.

17.16.1 Program Mode (n = 1 for addresses H'000000 to H'03FFFF, and n = 2 for addresses H'040000 to H'07FFFF)

Follow the procedure shown in the program/program-verify flowchart in figure 17.45 to write data or programs to flash memory. Performing program operations according to this flowchart will enable data or programs to be written to flash memory without subjecting the device to voltage stress or sacrificing program data reliability. Programming should be carried out 128 bytes at a time.

For the wait times (x , y , $z1$, $z2$, $z3$ α , β , γ , ε , η , and θ) after bits are set or cleared in flash memory control register n (FLMCR n) and the maximum number of programming operations (N), see section 20.3.6, Flash Memory Characteristics.

Following the elapse of (x) μ s or more after the SWEn bit is set to 1 in flash memory control register n (FLMCR n), 128-byte program data is stored in the program data area and reprogram

data area, and the 128-byte data in the reprogram data area is written consecutively to the write addresses. The lower 8 bits of the first address written to must be H'00 or H'80. The 128 consecutive byte data transfers are performed. The program address and program data are latched in the flash memory. A 128-byte data transfer must be performed even if writing fewer than 128 bytes; in this case, H'FF data must be written to the extra addresses.

Next, the watchdog timer is set to prevent overprogramming in the event of program runaway, etc. Set a value greater than $(y + z2 + \alpha + \beta) \mu\text{s}$ as the WDT overflow period. After this, preparation for program mode (program setup) is carried out by setting the PSUn bit in FLMCRn, and after the elapse of $(y) \mu\text{s}$ or more, the operating mode is switched to program mode by setting the Pn bit in FLMCRn. The time during which the Pn bit is set is the flash memory programming time. Set the programming time according to the table in the programming flowchart.

17.16.2 Program-Verify Mode (n = 1 for addresses H'000000 to H'03FFFF, and n = 2 for addresses H'040000 to H'07FFFF)

In program-verify mode, the data written in program mode is read to check whether it has been correctly written in the flash memory.

After the elapse of a given programming time, the programming mode is exited (the Pn bit in FLMCRn is cleared to 0, then the PSUn bit is cleared to 0 at least $(\alpha) \mu\text{s}$ later). Next, the watchdog timer is cleared after the elapse of $(\beta) \mu\text{s}$ or more, and the operating mode is switched to program-verify mode by setting the PVn bit in FLMCRn. Before reading in program-verify mode, a dummy write of H'FF data should be made to the addresses to be read. The dummy write should be executed after the elapse of $(\gamma) \mu\text{s}$ or more. When the flash memory is read in this state (verify data is read in 16-bit units), the data at the latched address is read. Wait at least $(\epsilon) \mu\text{s}$ after the dummy write before performing this read operation. Next, the originally written data is compared with the verify data, and reprogram data is computed (see figure 17.45) and transferred to the reprogram data area. After 128 bytes of data have been verified, exit program-verify mode and wait for at least $(\eta) \mu\text{s}$, then clear the SWEn bit in FLMCRn to 0, and wait again for at least $(\theta) \mu\text{s}$. If reprogramming is necessary, set program mode again, and repeat the program/program-verify sequence as before. However, ensure that the program/program-verify sequence is not repeated more than (N) times on the same bits.

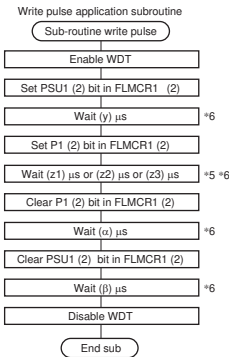

Note: 7. Write Pulse Width *6

Number of Writes (n)	Write Time (z) μs
1	z1
2	z1
3	z1
4	z1
5	z1
6	z1
7	z2
8	z2
9	z2
10	z2
11	z2
12	z2
13	z2
...	...
998	z2
999	z2
1000	z2

Note: Use a (z3) μs write pulse for additional programming.

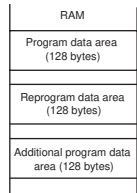

- Notes:
- Data transfer is performed by byte transfer. The lower 8 bits of the first address written to must be H'00 or H'80. A 128-byte data transfer must be performed even if writing fewer than 128 bytes; in this case, HFF dummy write to the extra addresses.
 - Verify data is read in 16-bit (W) units.
 - Even bits for which programming has been completed in the 128-byte programming loop will be subjected to additional programming if they fail the subsequent verify operation.
 - A 128-byte area for storing program data, a 128-byte area for storing reprogram data, and a 128-byte area for storing additional program data should be provided in RAM. The contents of the reprogram data and additional program data areas are modified as programming proceeds.
 - A write pulse of (z1) or (z2) μs should be applied according to the progress of programming. See Note *7 for the pulse widths. When the additional program data is programmed, a write pulse of (z3) μs should be applied. Reprogram data 'X' stands for reprogram data to which a write pulse has been applied.
 - For the values of x, y, z1, z2, z3, α, β, γ, ε, η, θ, and N, see section 20.3.6, Flash Memory Characteristics.

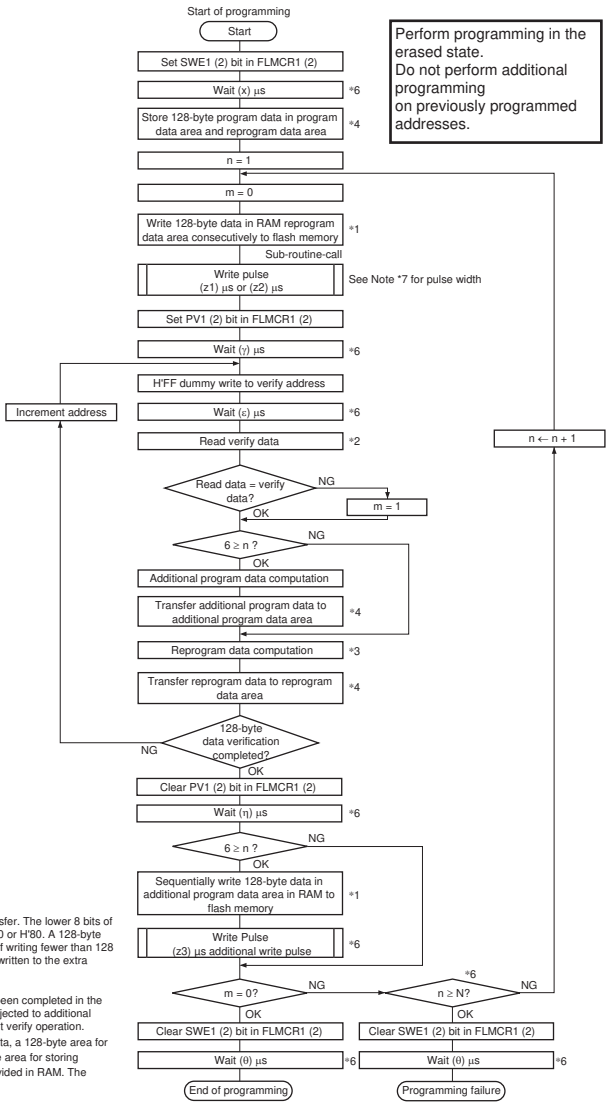

Perform programming in the erased state. Do not perform additional programming on previously programmed addresses.

Program Data Operation Chart

Original Data (D)	Verify Data (V)	Reprogram Data (X)	Comments
0	0	1	Programming completed
0	1	0	Programming incomplete; reprogram
1	0	1	Still in erased state; no action

Additional Program Data Operation Chart

Reprogram Data (X)	Verify Data (V)	Additional Program Data (Y)	Comments
0	0	0	Additional programming executed
0	1	1	Additional programming not executed
1	0	0	Additional programming not executed
1	1	1	Additional programming not executed

Figure 17.45 Program/Program-Verify Flowchart



17.16.3 Erase Mode (n = 1 for addresses H'000000 to H'03FFFF, and n = 2 for addresses H'040000 to H'07FFFF)

Flash memory erasing should be performed block by block following the procedure shown in the erase/erase-verify flowchart (single-block erase) shown in figure 17.46.

For the wait times (x , y , z , α , β , γ , ε , η , θ) after bits are set or cleared in flash memory control register n (FLMCR n) and the maximum number of programming operations (N), see section 20.3.6, Flash Memory Characteristics.

To perform data or program erasure, make a 1 bit setting for the flash memory area to be erased in erase block register 1 or 2 (EBR1 or EBR2) at least (x) μ s after setting the SWEn bit to 1 in flash memory control register n (FLMCR n). Next, the watchdog timer is set to prevent overerasing in the event of program runaway, etc. Set a value greater than ($y + z + \alpha + \beta$) ms as the WDT overflow period. After this, preparation for erase mode (erase setup) is carried out by setting the ESUn bit in FLMCR n , and after the elapse of (y) μ s or more, the operating mode is switched to erase mode by setting the En bit in FLMCR n . The time during which the En bit is set is the flash memory erase time. Ensure that the erase time does not exceed (z) ms.

Note: With flash memory erasing, prewriting (setting all data in the memory to be erased to 0) is not necessary before starting the erase procedure.

17.16.4 Erase-Verify Mode (n = 1 for addresses H'000000 to H'03FFFF, and n = 2 for addresses H'040000 to H'07FFFF)

In erase-verify mode, data is read after memory has been erased to check whether it has been correctly erased.

After the elapse of the erase time, erase mode is exited (the En bit in FLMCRn is cleared to 0, then the ESUn bit in FLMCRn is cleared to 0 at least (α) μ s later), the watchdog timer is cleared after the elapse of (β) μ s or more, and the operating mode is switched to erase-verify mode by setting the EVn bit in FLMCRn. Before reading in erase-verify mode, a dummy write of H'FF data should be made to the addresses to be read. The dummy write should be executed after the elapse of (γ) μ s or more. When the flash memory is read in this state (verify data is read in 16-bit units), the data at the latched address is read. Wait at least (ε) μ s after the dummy write before performing this read operation. If the read data has been erased (all 1), a dummy write is performed to the next address, and erase-verify is performed. If the read data has not been erased, set erase mode again, and repeat the erase/erase-verify sequence in the same way. However, ensure that the erase/erase-verify sequence is not repeated more than (N) times. When verification is completed, exit erase-verify mode, and wait for at least (η) μ s. If erasure has been completed on all the erase blocks, clear the SWEn bit in FLMCRn to 0 and wait for at least (θ) μ s. If there are any unerased blocks, make a 1 bit setting for the flash memory area to be erased, and repeat the erase/erase-verify sequence in the same way.

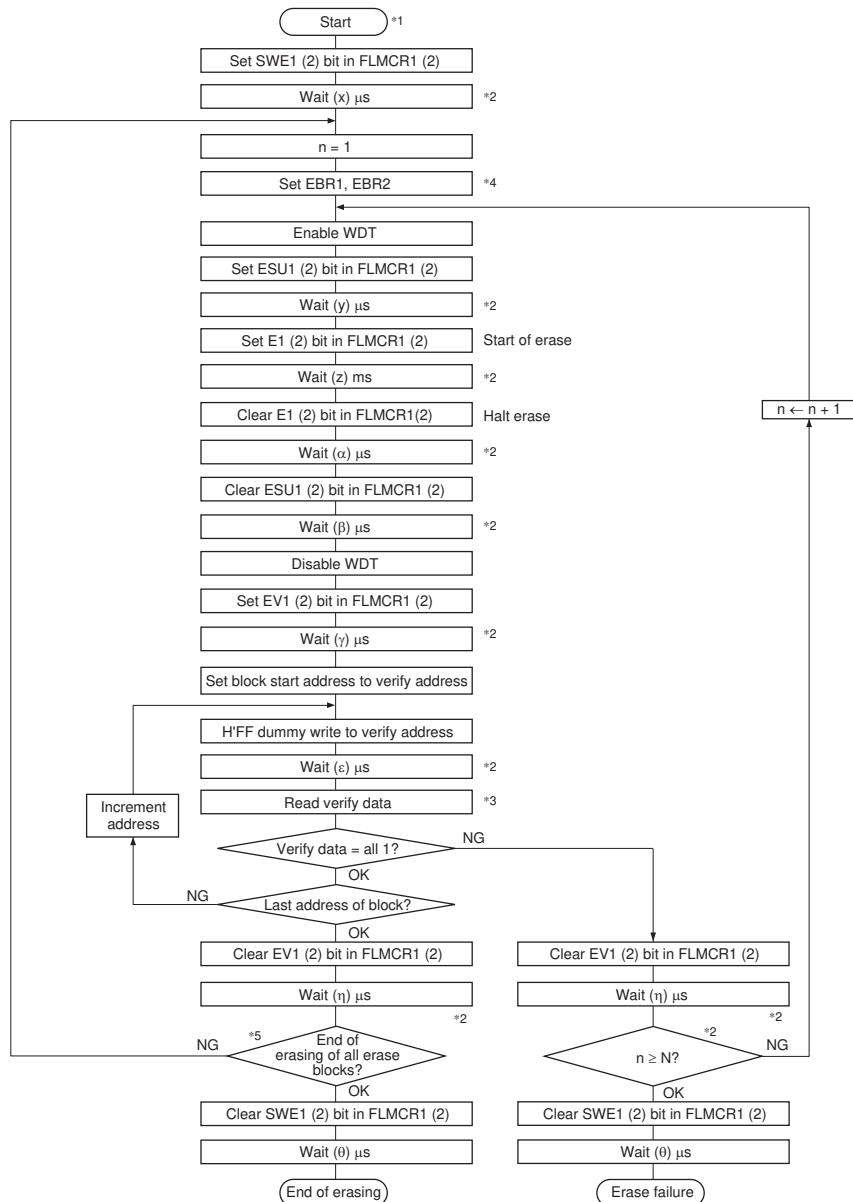

- Notes:
1. Prewriting (setting erase block data to all 0) is not necessary.
 2. The values of x, y, z, α, β, γ, ε, η, θ, and N are shown in section 20.3.6, Flash Memory Characteristics.
 3. Verify data is read in 16-bit (W) units.
 4. Set only one bit in EBR1 or EBR2. More than one bit cannot be set.
 5. Erasing is performed in block units. To erase a number of blocks, the individual blocks must be erased sequentially.

Figure 17.46 Erase/Erase-Verify Flowchart

17.17 Flash Memory Protection

There are three kinds of flash memory program/erase protection: hardware protection, software protection, and error protection.

17.17.1 Hardware Protection

Hardware protection refers to a state in which programming/erasing of flash memory is forcibly disabled or aborted. Settings in flash memory control registers 1 and 2 (FLMCR1, FLMCR2) and erase block registers 1 and 2 (EBR1, EBR2) are reset (see table 17.32).

Table 17.32 Hardware Protection

Item	Description	Functions	
		Program	Erase
Reset/standby protection	<ul style="list-style-type: none"> In a reset (including a WDT overflow reset) and in standby mode, FLMCR1, FLMCR2, EBR1, and EBR2 are initialized, and the program/erase-protected state is entered. In a reset via the $\overline{\text{RES}}$ pin, the reset state is not entered unless the $\overline{\text{RES}}$ pin is held low until oscillation stabilizes after powering on. In the case of a reset during operation, hold the $\overline{\text{RES}}$ pin low for the $\overline{\text{RES}}$ pulse width specified in section 20.3.3, AC Characteristics. 	Yes	Yes

17.17.2 Software Protection

Software protection can be implemented by setting the SWE1 bit in flash memory control register 1 (FLMCR1), SWE2 bit in FLMCR2 erase block registers 1 and 2 (EBR1, EBR2), and the RAMS bit in the RAM emulation register (RAMER). When software protection is in effect, setting the P1 or E1 bit in FLMCR1, or the P2 or E2 bit in FLMCR2 does not cause a transition to program mode or erase mode (see table 17.33).

Table 17.33 Software Protection

Item	Description	Functions	
		Program	Erase
SWE bit protection	<ul style="list-style-type: none"> Clearing the SWE1 bit to 0 in FLMCR1 sets the program/erase-protected state for area H'000000 to H'03FFFF (Execute in on-chip RAM, external memory, or addresses H'040000 to H'07FFFF) Clearing the SWE2 bit to 0 in FLMCR2 sets the program/erase-protected state for area H'040000 to H'07FFFF (Execute in on-chip RAM, external memory, or addresses H'000000 to H'03FFFF) 	Yes	Yes
Block specification protection	<ul style="list-style-type: none"> Erase protection can be set for individual blocks by settings in erase block registers 1 and 2 (EBR1, EBR2). Setting EBR1 and EBR2 to H'00 places all blocks in the erase-protected state. 	—	Yes
Emulation protection	<ul style="list-style-type: none"> Setting the RAMS bit to 1 in the RAM emulation register (RAMER) places all blocks in the program/erase-protected state. 	Yes	Yes

17.17.3 Error Protection

In error protection, an error is detected when MCU runaway occurs during flash memory programming/erasing, or operation is not performed in accordance with the program/erase algorithm, and the program/erase operation is aborted. Aborting the program/erase operation prevents damage to the flash memory due to overprogramming or overerasing.

If the MCU malfunctions during flash memory programming/erasing, the FLER bit is set to 1 in FLMCR2 and the error protection state is entered. The FLMCR1, FLMCR2, EBR1, and EBR2 settings are retained, but program mode or erase mode is aborted at the point at which the error occurred. Program mode or erase mode cannot be re-entered by re-setting the P1, P2, E1, or E2 bit. However, PV1, PV2, EV1, and EV2 bit setting is enabled, and a transition can be made to verify mode.

FLER bit setting conditions are as follows:

- When flash memory is read during programming/erasing (including a vector read or instruction fetch)
- Immediately after exception handling (excluding a reset) during programming/erasing
- When a SLEEP instruction (including software standby) is executed during programming/erasing
- When a bus master other than the CPU (the DTC) has control of the bus during programming/erasing

Error protection is released only by a reset and in hardware standby mode.

Figure 17.47 shows the flash memory state transition diagram.

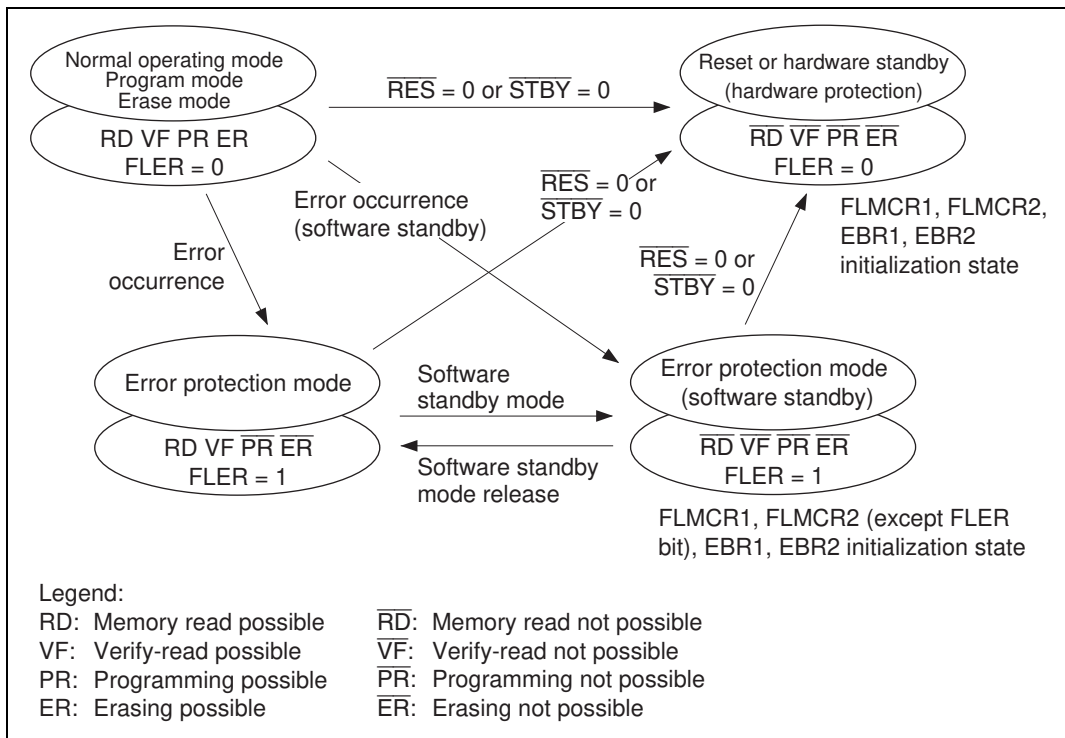

Figure 17.47 Flash Memory State Transitions

17.18 Flash Memory Emulation in RAM

17.18.1 Emulation in RAM

Making a setting in the RAM emulation register (RAMER) enables part of RAM to be overlapped onto the flash memory area so that data to be written to flash memory can be emulated in RAM in real time. After the RAMER setting has been made, accesses can be made from the flash memory area or the RAM area overlapping flash memory. Emulation can be performed in user mode and user program mode. Figure 17.48 shows an example of emulation of real-time flash memory programming.

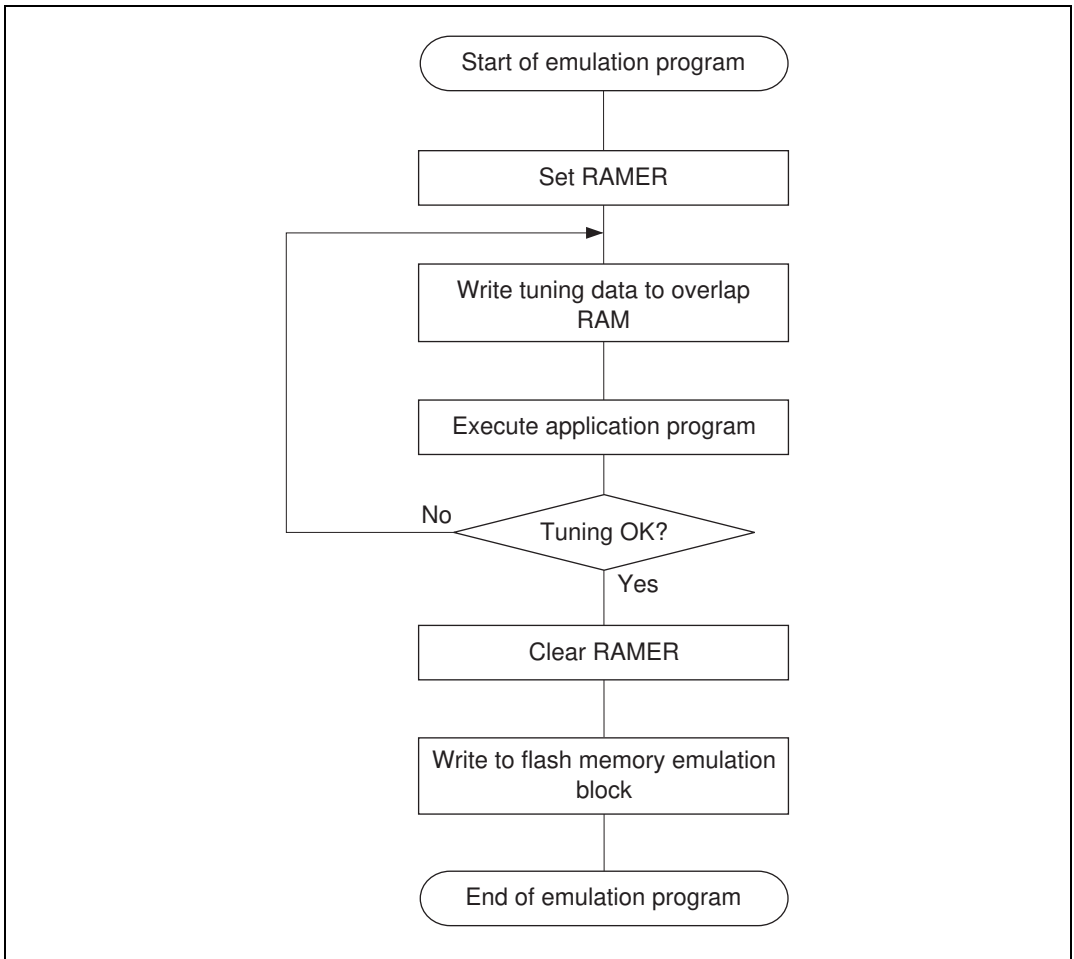

Figure 17.48 Flowchart for Flash Memory Emulation in RAM

17.18.2 RAM Overlap

An example in which flash memory block area EB1 is overlapped is shown below.

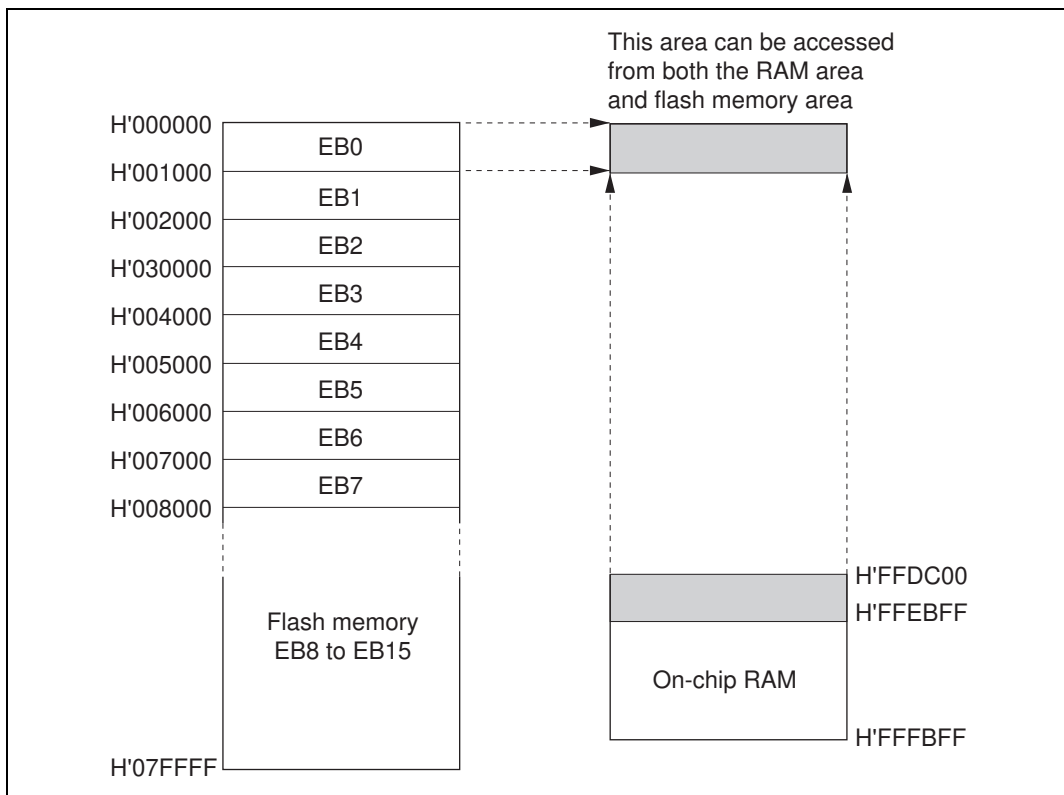

Figure 17.49 Example of RAM Overlap Operation

Example in Which Flash Memory Block Area EB1 Is Overlapped

1. Set bits RAMS, RAM2, RAM1, and RAM0 in RAMER to 1, 0, 0, 1, to overlap part of RAM onto the area (EB1) for which real-time programming is required.
2. Real-time programming is performed using the overlapping RAM.
3. After the program data has been confirmed, the RAMS bit is cleared, releasing RAM overlap.
4. The data written in the overlapping RAM is written into the flash memory space (EB1).

Notes: 1. When the RAMS bit is set to 1, program/erase protection is enabled for all blocks regardless of the value of RAM2, RAM1, and RAM0 (emulation protection). In this state, setting the P1 or E1 bit in flash memory control register 1 (FLMCR1), or setting

the P2 or E2 bit in FLMCR2 will not cause a transition to program mode or erase mode. When actually programming a flash memory area, the RAMS bit should be cleared to 0.

2. A RAM area cannot be erased by execution of software in accordance with the erase algorithm while flash memory emulation in RAM is being used.
3. Block area EB0 includes the vector table. When performing RAM emulation, the vector table is needed by the overlap RAM.

17.19 Interrupt Handling when Programming/Erasing Flash Memory

All interrupts, including NMI input, are disabled when flash memory is being programmed or erased (when the P1 or E1 bit is set in FLMCR1, or the P2 or E2 bit is set in FLMCR2), and while the boot program is executing in boot mode^{*1}, to give priority to the program or erase operation.

There are three reasons for this:

1. Interrupt during programming or erasing might cause a violation of the programming or erasing algorithm, with the result that normal operation could not be assured.
2. In the interrupt exception handling sequence during programming or erasing, the vector would not be read correctly^{*2}, possibly resulting in MCU runaway.
3. If an interrupt occurred during boot program execution, it would not be possible to execute the normal boot mode sequence.

For these reasons, in on-board programming mode alone there are conditions for disabling interrupts, as an exception to the general rule. However, this provision does not guarantee normal erasing and programming or MCU operation. All requests, including NMI, must therefore be restricted inside and outside the MCU when programming or erasing flash memory. The NMI interrupt is also disabled in the error-protection state while the P1 or E1 bit remains set in FLMCR1, or the P2 or E2 bit remains set in FLMCR2.

- Notes:
1. Interrupt requests must be disabled inside and outside the MCU until the programming control program has completed programming.
 2. The vector may not be read correctly in this case for the following two reasons:
 - If flash memory is read while being programmed or erased (while the P1 or E1 bit is set in FLMCR1, or the P2 or E2 bit is set in FLMCR2), correct read data will not be obtained (undetermined values will be returned).
 - If the interrupt entry in the vector table has not been programmed yet, interrupt exception handling will not be executed correctly.

17.20 Flash Memory Programmer Mode

17.20.1 Programmer Mode Setting

Programs and data can be written and erased in programmer mode as well as in the on-board programming modes. In programmer mode, the on-chip ROM can be freely programmed using a PROM programmer that supports the Renesas Technology microcomputer device type with 512-kbyte on-chip flash memory (FZTAT512V3A). Flash memory read mode, auto-program mode, auto-erase mode, and status read mode are supported with this device type. In auto-program mode, auto-erase mode, and status read mode, a status polling procedure is used, and in status read mode, detailed internal signals are output after execution of an auto-program or auto-erase operation.

Table 17.34 shows programmer mode pin settings.

Table 17.34 Programmer Mode Pin Settings

Pin Names	Settings/External Circuit Connection
Mode pins: MD2, MD1, MD0	Low-level input
Mode setting pins: PF2, PF1, PF0	High-level input to PF2, low-level input to PF1 and PF0
$\overline{\text{STBY}}$ pin	High-level input (do not select hardware standby mode)
$\overline{\text{RES}}$ pin	Reset circuit
XTAL, EXTAL pins	Oscillator circuit
Other pins requiring setting: P23, P25	High-level input to P23, low-level input to P25

17.20.2 Socket Adapters and Memory Map

In programmer mode, a socket adapter is connected to the chip as shown in figure 17.51. This enables the chip to fit a 40-pin socket. Figure 17.50 shows the on-chip ROM memory map and figure 17.51 shows the socket adapter pin assignments.

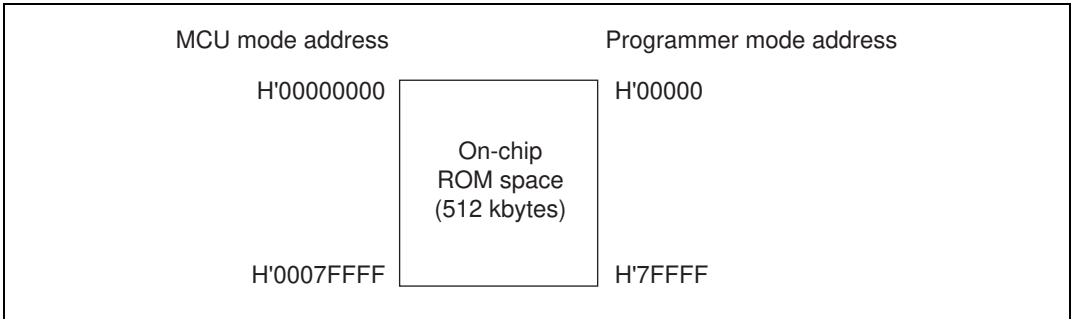

Figure 17.50 Memory Map in Programmer Mode

H8S/2319 F-ZTAT			Socket Adapter (40-Pin Conversion)	HN27C4096HG (40 Pins)	
TFP-100B	FP-100A	Pin Name		Pin No.	Pin Name
32	34	A ₀		21	A ₀
33	35	A ₁		22	A ₁
34	36	A ₂		23	A ₂
35	37	A ₃		24	A ₃
36	38	A ₄		25	A ₄
37	39	A ₅		26	A ₅
38	40	A ₆		27	A ₆
39	41	A ₇		28	A ₇
41	43	A ₈		29	A ₈
42	44	A ₉		31	A ₉
43	45	A ₁₀		32	A ₁₀
44	46	A ₁₁		33	A ₁₁
45	47	A ₁₂		34	A ₁₂
46	48	A ₁₃		35	A ₁₃
47	49	A ₁₄		36	A ₁₄
48	50	A ₁₅		37	A ₁₅
50	52	A ₁₆		38	A ₁₆
51	53	A ₁₇		39	A ₁₇
52	54	A ₁₈		10	A ₁₈
53	55	A ₁₉		9	A ₁₉
99	1	A ₂₀		8	A ₂₀
23	25	D ₈		19	I/O ₀
24	26	D ₉		18	I/O ₁
25	27	D ₁₀		17	I/O ₂
26	28	D ₁₁		16	I/O ₃
27	29	D ₁₂		15	I/O ₄
28	30	D ₁₃		14	I/O ₅
29	31	D ₁₄		13	I/O ₆
30	32	D ₁₅		12	I/O ₇
55	57	\overline{CE}		2	\overline{CE}
54	56	\overline{OE}		20	\overline{OE}
56	58	\overline{WE}		3	\overline{WE}
60	62	EMLE ^{*3}		4	FWE
40, 63, 64, 65, 74, 77, 78, 98, 59	42, 65, 66, 67, 76, 79, 80, 100, 61	V _{CC}		1, 40	V _{CC}
7, 18, 31, 49, 57, 58, 61, 68, 75, 76, 87, 88, 90	9, 20, 33, 51, 59, 60, 63, 70, 77, 78, 89, 90, 92	V _{SS}		11, 30	V _{SS}
62	64	\overline{RES}	Reset circuit	5, 6, 7	NC
66	68	XTAL	Oscillation circuit		
67	69	EXTAL			
Other pins		NC (OPEN)			

Notes: This figure shows pin assignments, and does not show the entire socket adapter circuit.

1. A reset oscillation stabilization time (t_{osc1}) of at least 10 ms is required.
2. A 12-MHz crystal resonator should be used.
3. As the FWE pin becomes V_{CC} in the H8S/2319 F-ZTAT, the EMLE pin is ignored in programmer mode.

Legend:
 EMLE: Emulation enable
 I/O₇ to I/O₀: Data input/output
 A₁₈ to A₀: Address input
 CE: Chip enable
 OE: Output enable
 WE: Write enable

Figure 17.51 H8S/2319F-ZTAT Socket Adapter Pin Assignments

17.20.3 Programmer Mode Operation

Table 17.35 shows how the different operating modes are set when using programmer mode, and table 17.36 lists the commands used in programmer mode. Details of each mode are given below.

Memory Read Mode: Memory read mode supports byte reads.

Auto-Program Mode: Auto-program mode supports programming of 128 bytes at a time. Status polling is used to confirm the end of auto-programming.

Auto-Erase Mode: Auto-erase mode supports automatic erasing of the entire flash memory. Status polling is used to confirm the end of auto-erasing.

Status Read Mode: Status polling is used for auto-programming and auto-erasing, and normal termination can be confirmed by reading the I/O₆ signal. In status read mode, error information is output if an error occurs.

Table 17.35 Settings for Each Operating Mode in Programmer Mode

Mode	Pin Names				
	\overline{CE}	\overline{OE}	\overline{WE}	I/O ₇ to I/O ₀	A ₁₈ to A ₀
Read	L	L	H	Data output	Ain
Output disable	L	H	H	Hi-Z	×
Command write	L	H	L	Data input	Ain ^{*2}
Chip disable ^{*1}	H	×	×	Hi-Z	×

Legend:

H: High level

L: Low level

Hi-Z: High impedance

×: Don't care

Notes: 1. Chip disable is not a standby state; internally, it is an operation state.

2. Ain indicates that there is also address input in auto-program mode.

Table 17.36 Programmer Mode Commands

Command Name	Number of Cycles	1st Cycle			2nd Cycle		
		Mode	Address	Data	Mode	Address	Data
Memory read mode	1 + n	Write	×	H'00	Read	RA	Dout
Auto-program mode	129	Write	×	H'40	Write	PA	Din
Auto-erase mode	2	Write	×	H'20	Write	×	H'20
Status read mode	2	Write	×	H'71	Write	×	H'71

Legend:

RA: Read address

PA: Program address

×: Don't care

Notes: 1. In auto-program mode, 129 cycles are required for command writing by a simultaneous 128-byte write.
 2. In memory read mode, the number of cycles depends on the number of address write cycles (n).

17.20.4 Memory Read Mode

- After the end of an auto-program, auto-erase, or status read operation, the command wait state is entered. To read memory contents, a transition must be made to memory read mode by means of a command write before the read is executed.
- Command writes can be performed in memory read mode, just as in the command wait state.
- Once memory read mode has been entered, consecutive reads can be performed.
- After power-on, memory read mode is entered.

Table 17.37 AC Characteristics in Memory Read ModeConditions: $V_{CC} = 3.3 \text{ V} \pm 0.3 \text{ V}$, $V_{SS} = 0 \text{ V}$, $T_a = 25^\circ\text{C} \pm 5^\circ\text{C}$

Item	Symbol	Min	Max	Unit
Command write cycle	t_{nxtc}	20	—	μs
$\overline{\text{CE}}$ hold time	t_{ceh}	0	—	ns
$\overline{\text{CE}}$ setup time	t_{ces}	0	—	ns
Data hold time	t_{dh}	50	—	ns
Data setup time	t_{ds}	50	—	ns
Write pulse width	t_{wep}	70	—	ns
$\overline{\text{WE}}$ rise time	t_r	—	30	ns
$\overline{\text{WE}}$ fall time	t_f	—	30	ns

**Figure 17.52 Memory Read Mode Timing Waveforms after Command Write**

Table 17.38 AC Characteristics when Entering Another Mode from Memory Read Mode

Conditions: $V_{CC} = 3.3\text{ V} \pm 0.3\text{ V}$, $V_{SS} = 0\text{ V}$, $T_a = 25^\circ\text{C} \pm 5^\circ\text{C}$

Item	Symbol	Min	Max	Unit
Command write cycle	t_{nxtc}	20	—	μs
$\overline{\text{CE}}$ hold time	t_{ceh}	0	—	ns
$\overline{\text{CE}}$ setup time	t_{ces}	0	—	ns
Data hold time	t_{dh}	50	—	ns
Data setup time	t_{ds}	50	—	ns
Write pulse width	t_{wep}	70	—	ns
$\overline{\text{WE}}$ rise time	t_r	—	30	ns
$\overline{\text{WE}}$ fall time	t_f	—	30	ns

**Figure 17.53 Timing Waveforms when Entering Another Mode from Memory Read Mode**

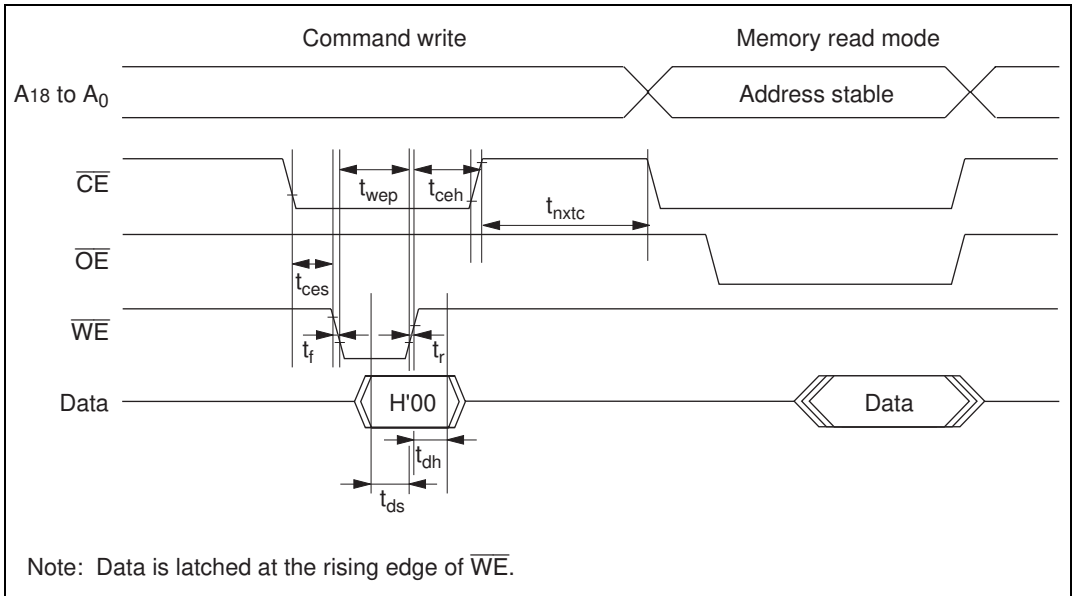
Table 17.39 AC Characteristics in Memory Read ModeConditions: $V_{CC} = 3.3 \text{ V} \pm 0.3 \text{ V}$, $V_{SS} = 0 \text{ V}$, $T_a = 25^\circ\text{C} \pm 5^\circ\text{C}$

Item	Symbol	Min	Max	Unit
Access time	t_{acc}	—	20	μs
$\overline{\text{CE}}$ output delay time	t_{ce}	—	150	ns
$\overline{\text{OE}}$ output delay time	t_{oe}	—	150	ns
Output disable delay time	t_{df}	—	100	ns
Data output hold time	t_{oh}	5	—	ns

**Figure 17.54 Timing Waveforms for $\overline{\text{CE}}/\overline{\text{OE}}$ Enable State Read****Figure 17.55 Timing Waveforms for $\overline{\text{CE}}/\overline{\text{OE}}$ Clocked Read**

17.20.5 Auto-Program Mode

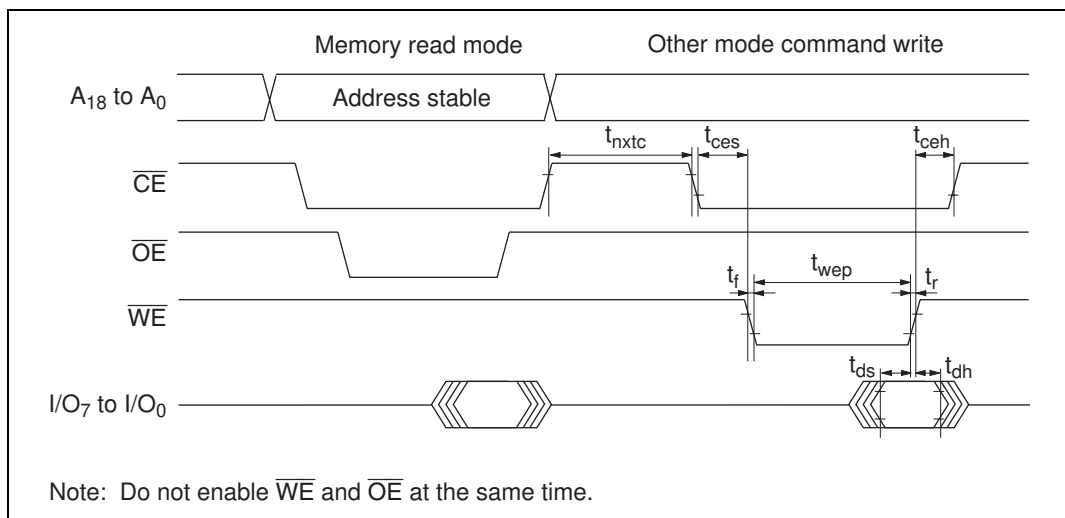
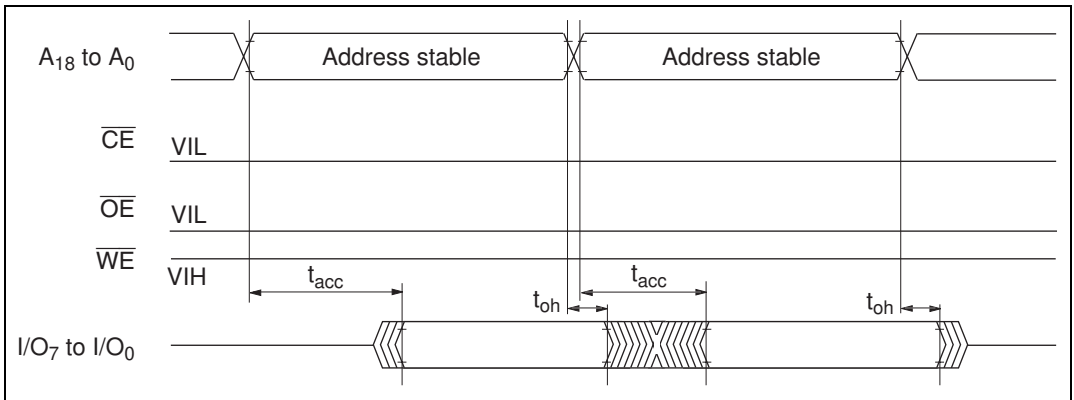
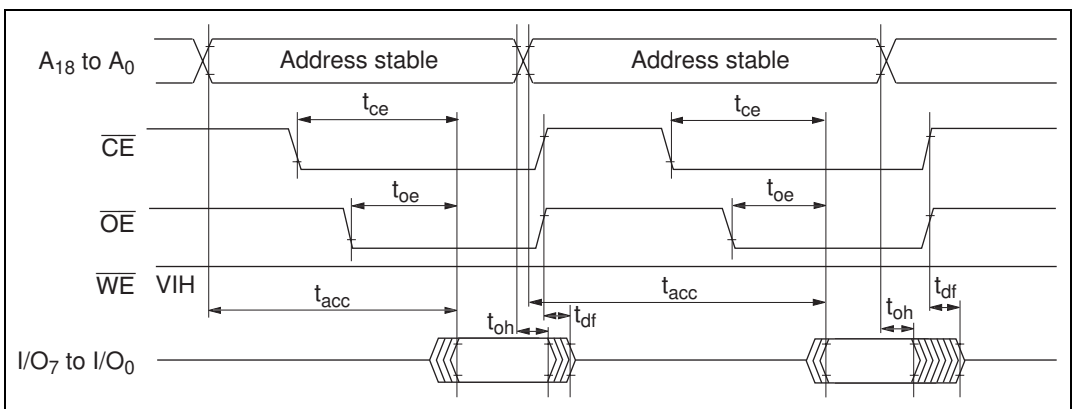
- In auto-program mode, 128 bytes are programmed simultaneously. For this purpose, 128 consecutive byte data transfers should be performed.
- A 128-byte data transfer must be performed even if writing fewer than 128 bytes; in this case, H'FF data must be written to the extra addresses.
- The lower 7 bits of the transfer address must be held low. If an invalid address is input, memory programming will be started but a programming error will occur.
- Memory address transfer is executed in the second cycle (figure 17.56). Do not perform transfer later than the second cycle.
- Do not perform a command write during a programming operation.
- Perform one auto-programming operation for a 128-byte block for each address. One or more additional programming operations cannot be carried out on address blocks that have already been programmed.
- Confirm normal end of auto-programming by checking I/O_6 . Alternatively, status read mode can also be used for this purpose (the I/O_7 status polling pin is used to identify the end of an auto-program operation).
- Status polling I/O_6 and I/O_7 information is retained until the next command write. As long as the next command write has not been performed, reading is possible by enabling \overline{CE} and \overline{OE} .

AC Characteristics

Table 17.40 AC Characteristics in Auto-Program Mode

Conditions: $V_{CC} = 3.3 \text{ V} \pm 0.3 \text{ V}$, $V_{SS} = 0 \text{ V}$, $T_a = 25^\circ\text{C} \pm 5^\circ\text{C}$

Item	Symbol	Min	Max	Unit
Command write cycle	t_{nxtc}	20	—	μs
$\overline{\text{CE}}$ hold time	t_{ceh}	0	—	ns
$\overline{\text{CE}}$ setup time	t_{ces}	0	—	ns
Data hold time	t_{dh}	50	—	ns
Data setup time	t_{ds}	50	—	ns
Write pulse width	t_{wep}	70	—	ns
Status polling start time	t_{wsts}	1	—	ms
Status polling access time	t_{spa}	—	150	ns
Address setup time	t_{as}	0	—	ns
Address hold time	t_{ah}	60	—	ns
Memory write time	t_{write}	1	3000	ms
$\overline{\text{WE}}$ rise time	t_r	—	30	ns
$\overline{\text{WE}}$ fall time	t_f	—	30	ns

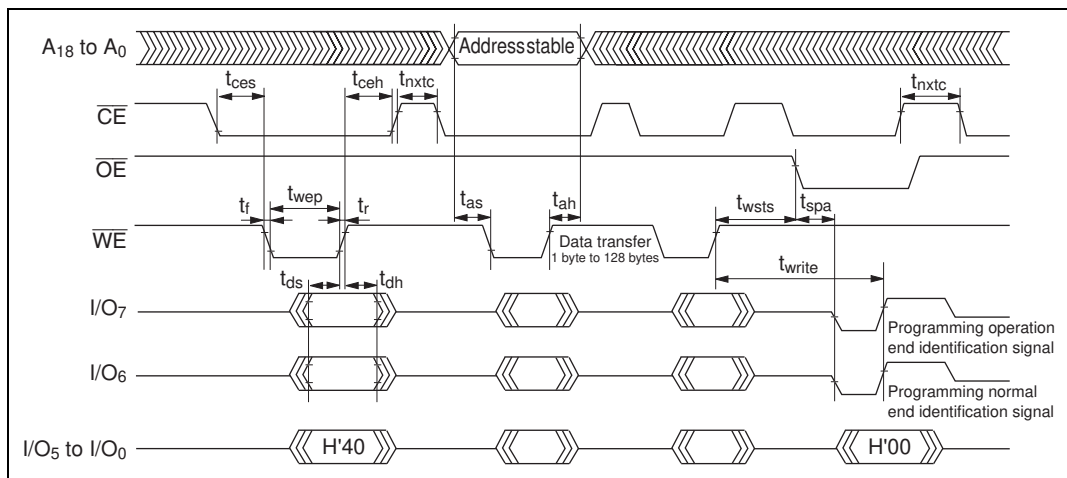

Figure 17.56 Auto-Program Mode Timing Waveforms

17.20.6 Auto-Erase Mode

- Auto-erase mode supports only total memory erasing.
- Do not perform a command write during auto-erasing.
- Confirm normal end of auto-erasing by checking I/O₆. Alternatively, status read mode can also be used for this purpose (the I/O₇ status polling pin is used to identify the end of an auto-erase operation).
- Status polling I/O₆ and I/O₇ pin information is retained until the next command write. As long as the next command write has not been performed, reading is possible by enabling $\overline{\text{CE}}$ and $\overline{\text{OE}}$.

AC Characteristics

Table 17.41 AC Characteristics in Auto-Erase Mode

Conditions: $V_{CC} = 3.3 \text{ V} \pm 0.3 \text{ V}$, $V_{SS} = 0 \text{ V}$, $T_a = 25^\circ\text{C} \pm 5^\circ\text{C}$

Item	Symbol	Min	Max	Unit
Command write cycle	t_{nxtc}	20	—	μs
$\overline{\text{CE}}$ hold time	t_{ceh}	0	—	ns
$\overline{\text{CE}}$ setup time	t_{ces}	0	—	ns
Data hold time	t_{dh}	50	—	ns
Data setup time	t_{ds}	50	—	ns
Write pulse width	t_{wep}	70	—	ns
Status polling start time	t_{ests}	1	—	ms
Status polling access time	t_{spa}	—	150	ns
Memory erase time	t_{erase}	100	40000	ms
$\overline{\text{WE}}$ rise time	t_{r}	—	30	ns
$\overline{\text{WE}}$ fall time	t_{f}	—	30	ns

Table 17.44 Status Polling Output Truth Table

Pin Names	Internal Operation in Progress	Abnormal End	—	Normal End
I/O ₇	0	1	0	1
I/O ₆	0	0	1	1
I/O ₀ to I/O ₅	0	0	0	0

17.20.9 Programmer Mode Transition Time

Commands cannot be accepted during the oscillation stabilization period or the programmer mode setup period. After the programmer mode setup time, a transition is made to memory read mode.

Table 17.45 Command Wait State Transition Time Specifications

Item	Symbol	Min	Max	Unit
Standby release (oscillation stabilization time)	t_{osc1}	30	—	ms
Programmer mode setup time	t_{bmv}	10	—	ms
V_{CC} hold time	t_{dwn}	0	—	ms

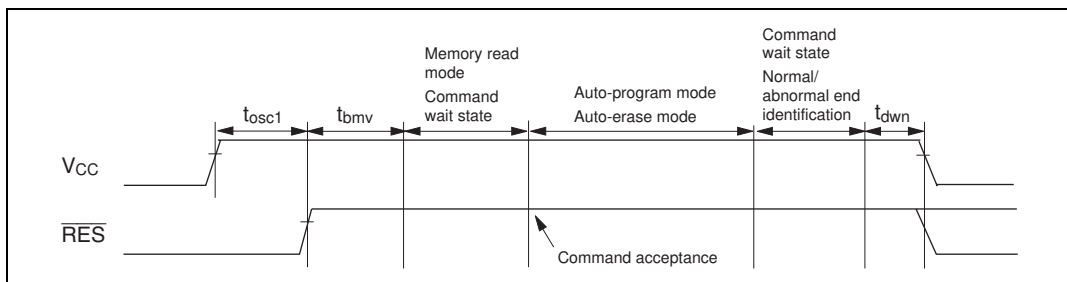

Figure 17.59 Oscillation Stabilization Time, Programmer Mode Setup Time, and Power Supply Fall Sequence

17.20.10 Notes on Memory Programming

- When programming addresses which have previously been programmed, carry out auto-erasing before auto-programming.

- When performing programming using PROM mode on a chip that has been programmed/erased in an on-board programming mode, auto-erasing is recommended before carrying out auto-programming.

- Notes:
1. The flash memory is initially in the erased state when the device is shipped by Renesas Technology. For other chips for which the erasure history is unknown, it is recommended that auto-erasing be executed to check and supplement the initialization (erase) level.
 2. Auto-programming should be performed once only on the same address block. Additional programming cannot be carried out on address blocks that have already been programmed.

17.21 Flash Memory Programming and Erasing Precautions

Precautions concerning the use of on-board programming mode, the RAM emulation function, and programmer mode are summarized below.

Use the specified voltages and timing for programming and erasing: Applied voltages in excess of the rating can permanently damage the device. Use a PROM programmer that supports the Renesas Technology microcomputer device type with 512-kbyte on-chip flash memory (FZTAT512V3A).

Do not select the HN27C4096 setting for the PROM programmer, and only use the specified socket adapter. Failure to observe these points may result in damage to the device.

Powering on and off: When applying or disconnecting V_{CC} power, fix the \overline{RES} pin low and place the flash memory in the hardware protection state.

The power-on and power-off timing requirements should also be satisfied in the event of a power failure and subsequent recovery.

Use the recommended algorithm when programming and erasing flash memory: The recommended algorithm enables programming and erasing to be carried out without subjecting the device to voltage stress or sacrificing program data reliability. When setting the P1 or E1 bit in FLMCR1 or the P2 or E2 bit in FLMCR2, the watchdog timer should be set beforehand as a precaution against program runaway, etc.

Do not set or clear the SWE1 and SWE2 bit during execution of a program in flash memory: Wait for at least 100 μ s after clearing the SWE1 and SWE2 bit before executing a program or reading data in flash memory. When the SWE1 and SWE2 bit is set, data in flash memory can be rewritten, but addresses H'000000 to H'03FFFF in flash memory can only be read in program-verify or erase-verify mode when SWE1 = 1, and addresses H'040000 to H'07FFFF in flash memory can only be read in program-verify or erase-verify mode when SWE2 = 1. Access those address areas only for verify operations (verification during programming/erasing). Also, do not clear the SWE1 or SWE2 bit during programming, erasing, or verifying.

Similarly, when using the RAM emulation function the SWE1 bit must be cleared before executing a program or reading data in flash memory.

However, the RAM area overlapping flash memory space can be read and written to regardless of whether the SWE1 bit is set or cleared.

Do not use interrupts while flash memory is being programmed or erased: When flash memory is programmed or erased, all interrupt requests, including NMI, should be disabled to give priority to program/erase operations.

Do not perform additional programming. Erase the memory before reprogramming: In on-board programming, perform only one programming operation on a 128-byte programming unit block. In programmer mode, too, perform only one programming operation on a 128-byte programming unit block. Programming should be carried out with the entire programming unit block erased.

Before programming, check that the chip is correctly mounted in the PROM programmer: Overcurrent damage to the device can result if the index marks on the PROM programmer socket, socket adapter, and chip are not correctly aligned.

Do not touch the socket adapter or chip during programming: Touching either of these can cause contact faults and write errors.

17.22 Overview of Flash Memory (H8S/2319C 0.18 μ m F-ZTAT)

17.22.1 Features

This LSI has an on-chip 512-kbyte flash memory. The flash memory has the following features.

- Two flash-memory MATs according to LSI initiation mode
The on-chip flash memory has two memory spaces in the same address space (hereafter referred to as memory MATs). The mode setting in the initiation determines which memory MAT is initiated first. The MAT can be switched by using the bank-switching method after initiation.
 - The user memory MAT is initiated at a power-on reset in user mode: 512 kbytes
 - The user boot memory MAT is initiated at a power-on reset in user boot mode: 8 kbytes
- On-board programming modes
 - Boot mode
This mode is a program mode that uses an on-chip SCI interface. The user MAT and user boot MAT can be programmed. This mode can automatically adjust the bit rate between host and this LSI.
 - User program mode
The user MAT can be programmed by using the optional interface.
 - User boot mode
The user boot program of the optional interface can be made and the user MAT can be programmed.
- PROM mode
This mode uses the PROM programmer. The user MAT and user boot MAT can be programmed.
- Programming/erasing interface by the download of on-chip program
This LSI has a dedicated programming/erasing program. After downloading this program to the on-chip RAM, programming/erasing can be performed by setting the argument parameter.
- Emulation function of flash memory by using the on-chip RAM
As flash memory is overlapped with part of the on-chip RAM, the flash memory programming can be emulated in real time.
- Protection modes
There are three protection modes: software protection by the register setting, hardware protection by reset/hardware standby, and error protection. The protection state for flash memory programming/erasing can be set.

When abnormalities, such as runaway of programming/erasing are detected, these modes enter the error protection state and the programming/erasing processing is suspended.

- Programming/erasing time

The flash memory programming time is 3 ms (typ) for 128-byte simultaneous programming, which is equivalent to 25 μ s per byte. The erasing time is 1000 ms (typ) per 64-kbyte block.

- Number of programming

Flash memory programming can be performed a minimum of 100 times.

17.22.2 Overview

(1) Block Diagram

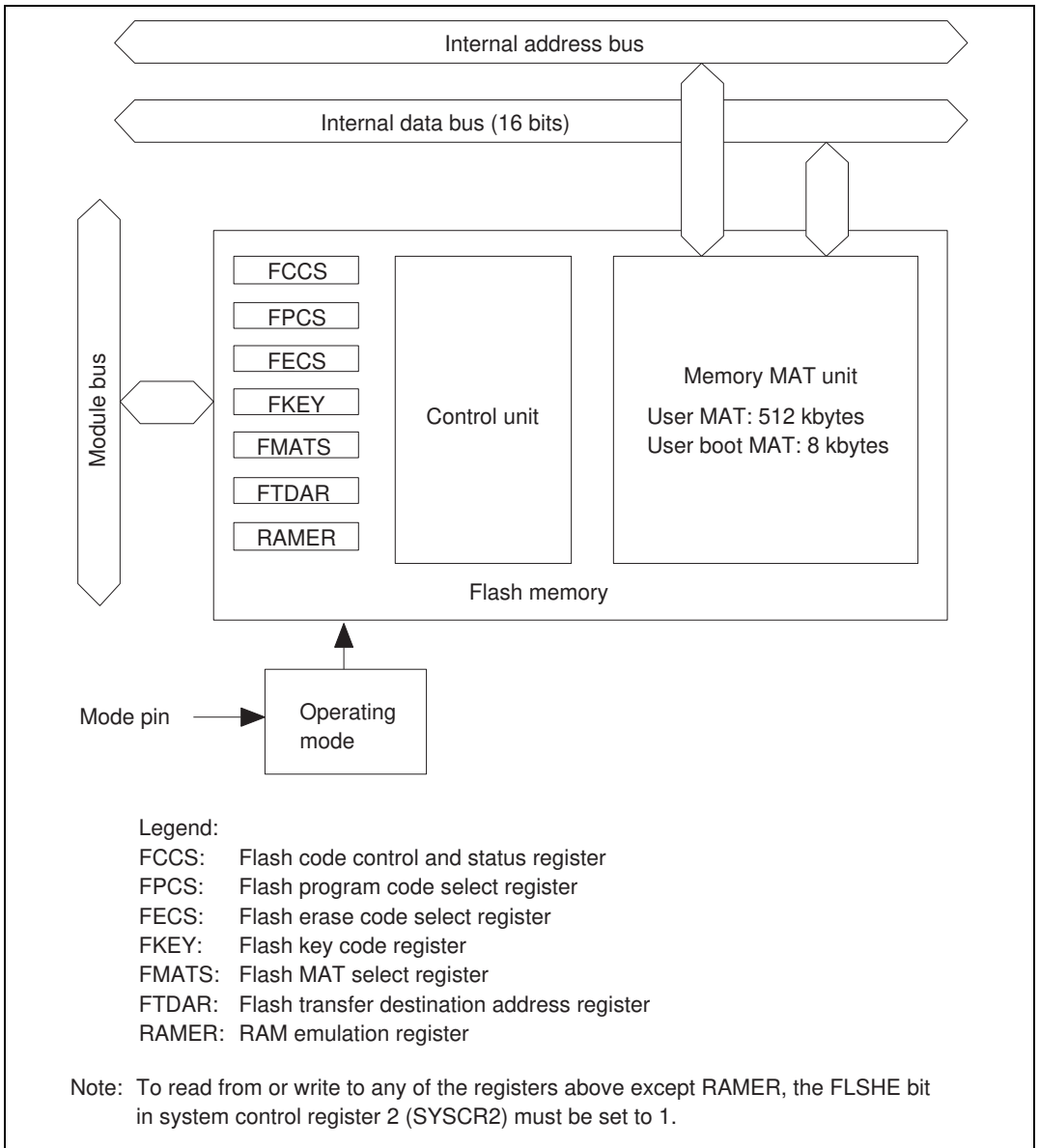

Figure 17.60 Block Diagram of Flash Memory

17.22.3 Operating Mode of Flash Memory

When each mode pin is set in the reset state and reset start is performed, the microcomputer enters each operating mode as shown in figure 17.61. For the setting of each mode pin, see table 17.52.

- Flash memory cannot be read, programmed, or erased in ROM invalid mode.
- Flash memory can be read in user mode, but cannot be programmed or erased.
- Flash memory can be read, programmed, or erased on the board only in user program mode, user boot mode, and boot mode.
- Flash memory can be read, programmed, or erased by means of the PROM programmer in PROM mode.

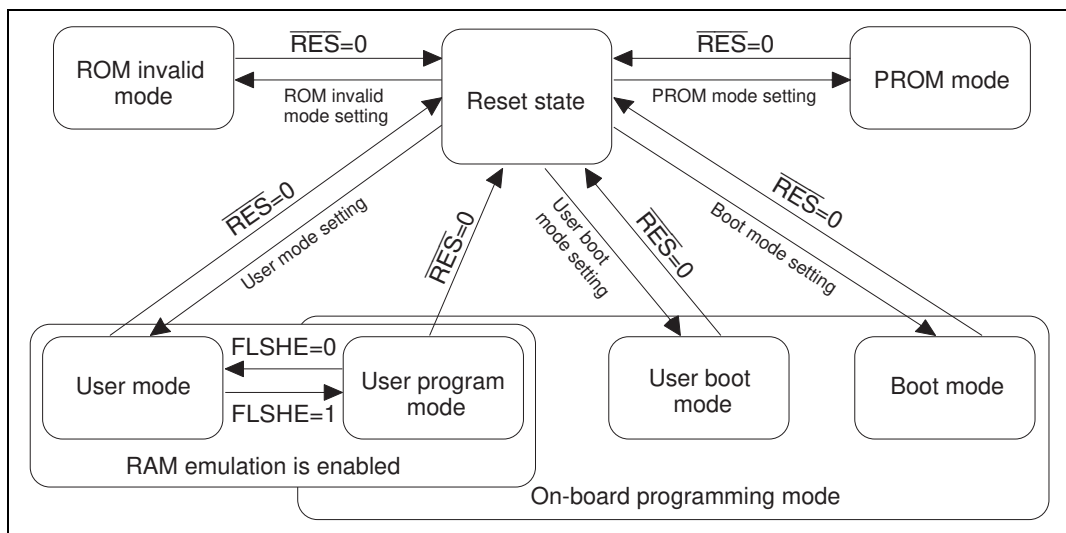

Figure 17.61 Mode Transition of Flash Memory

17.22.4 Mode Comparison

The comparison table of programming and erasing related items about boot mode, user program mode, user boot mode, and PROM mode is shown in table 17.46.

Table 17.46 Comparison of Programming Modes

	Boot mode	User program mode	User boot mode	PROM mode
Programming/ Erasing Environment	On-board programming	On-board programming	On-board programming	On-board programming
Programming/ Erasing Enable MAT	User MAT User boot MAT	User MAT	User MAT	User MAT User boot MAT
Program/Erase Control	Command method	Programming/ Erasing Interface	Programming/ Erasing Interface	Command method
All Erasure	○ (Automatic)	○	○	○ (Automatic)
Block Division Erasure	○ *1	○	○	×
Program Data Transfer	From host via SCI	From optional device via RAM	From optional device via RAM	Via programmer
RAM Emulation	×	○	×	×
Reset Initiation MAT	Embedded program storage MAT	User MAT	User boot MAT*2	—
Transition to User Mode	Mode setting change and reset	FLSHE bit setting change	Mode setting change and reset	—

Notes: 1. All-erasure is performed. After that, the specified block can be erased.

2. Initiation starts from the embedded program storage MAT. After checking the flash-memory related registers, initiation starts from the reset vector of the user MAT.

- The user boot MAT can be programmed or erased only in boot mode and PROM mode.
- The user MAT and user boot MAT are erased in boot mode. Then, the user MAT and user boot MAT can be programmed by means of the command method. However, the contents of the MAT cannot be read until this state.
Only user boot MAT is programmed and the user MAT is programmed in user boot mode or only user MAT is programmed because user boot mode is not used.
- The boot operation of the optional interface can be performed by the mode pin setting different from user program mode in user boot mode.

17.22.5 Flash MAT Configuration

This LSI's flash memory is configured by the 512-kbyte user MAT and 8-kbyte user boot MAT.

The start address is allocated to the same address in the user MAT and user boot MAT. Therefore, when the program execution or data access is performed between two MATs, the MAT must be switched by using FMATS.

The user MAT or user boot MAT can be read in all modes if it is in ROM valid mode. However, the user boot MAT can be programmed only in boot mode and PROM mode.

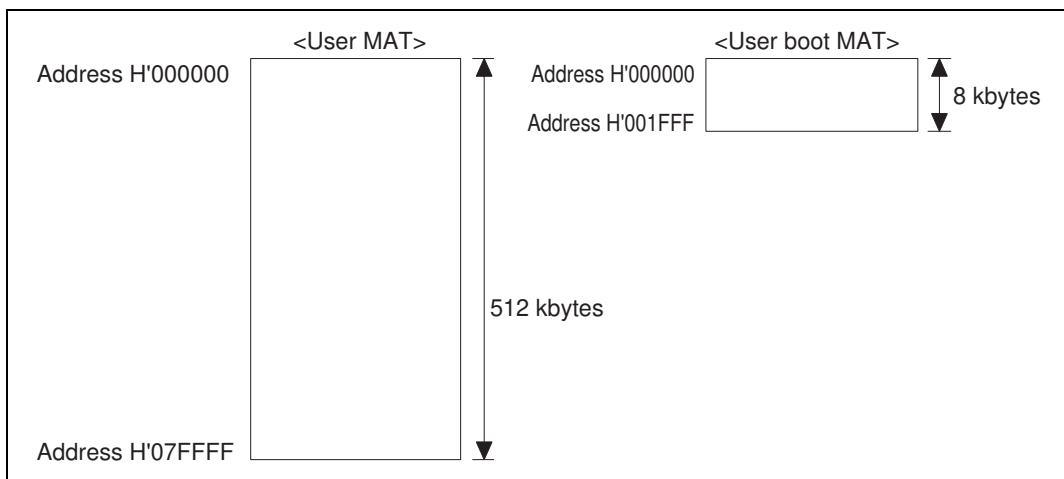

Figure 17.62 Flash Memory Configuration

The user MAT and user boot MAT have different memory sizes. Do not access a user boot MAT that is 8 kbytes or more. When a user boot MAT exceeding 8 kbytes is read from, an undefined value is read.

17.22.6 Block Division

The user MAT is divided into 64 kbytes (seven blocks), 32 kbytes (one block), and 4 kbytes (eight blocks) as shown in figure 17.63. The user MAT can be erased in this divided-block units and the erase-block number of EB0 to EB15 is specified when erasing.

The RAM emulation can be performed in the eight blocks of 4 kbytes.

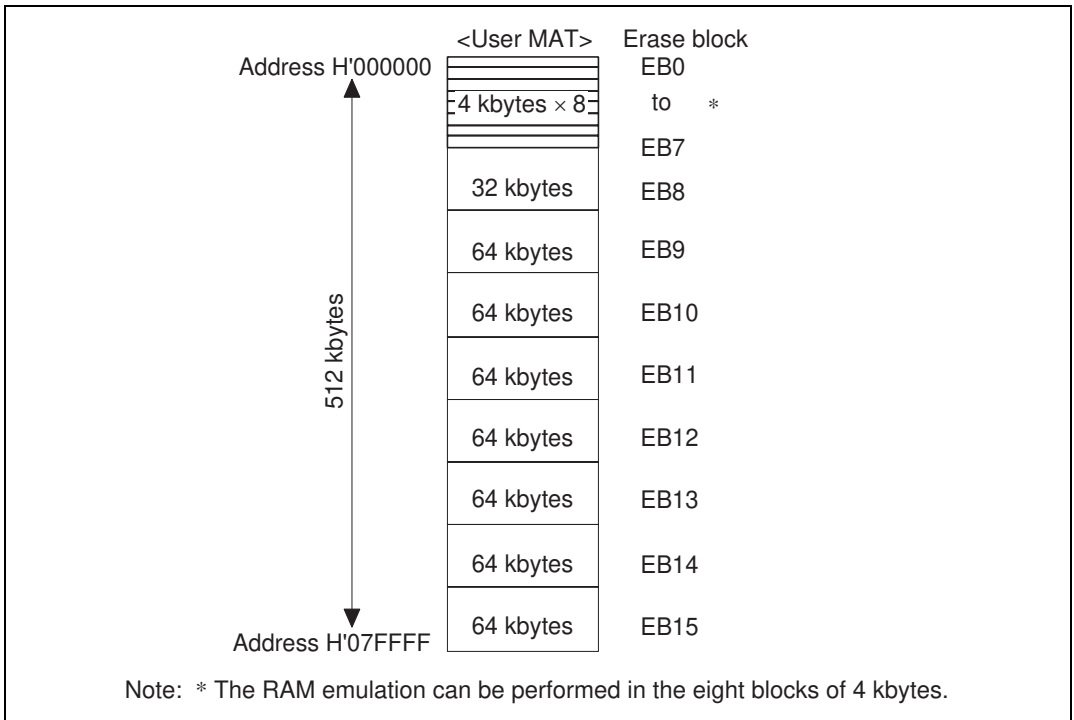

Figure 17.63 Block Division of User MAT

17.22.7 Programming/Erasing Interface

Programming/erasing is executed by downloading the on-chip program to the on-chip RAM and specifying the program address/data and erase block by using the interface register/parameter.

The procedure program is made by the user in user program mode and user boot mode. The overview of the procedure is as follows. For details, see section 17.24.2, User Program Mode.

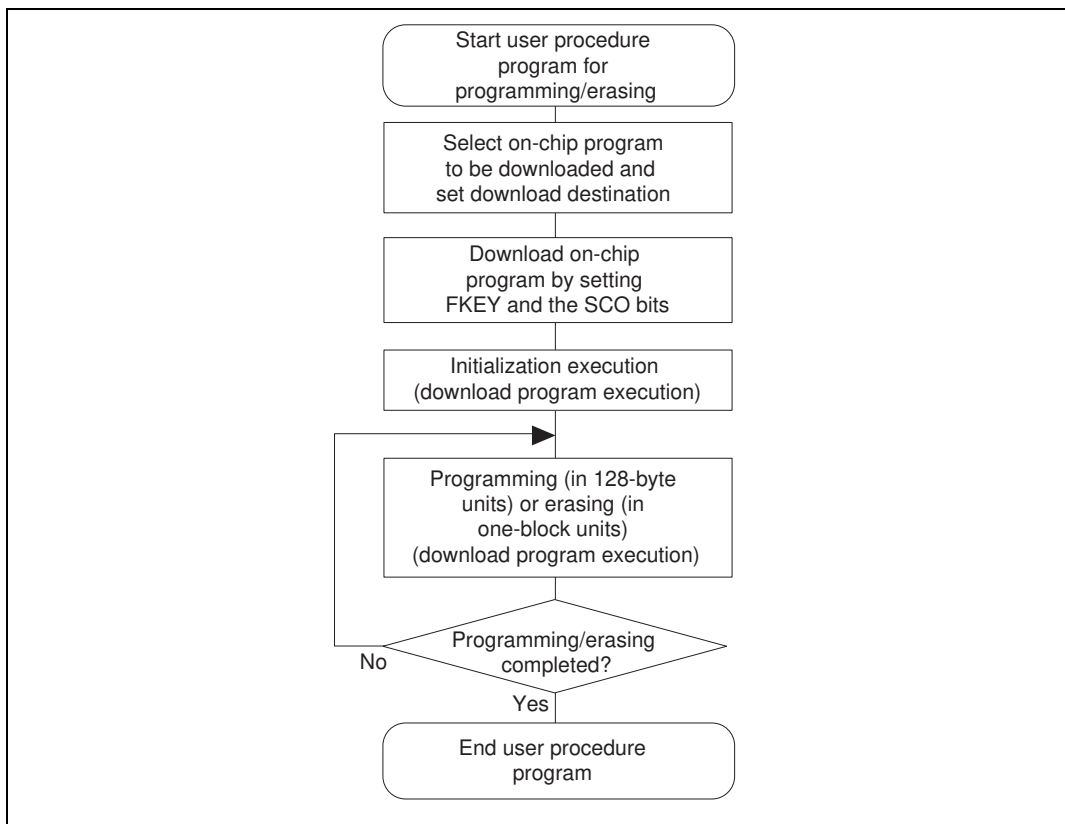

Figure 17.64 Overview of User Procedure Program

1. Selection of on-chip program to be downloaded and setting of download destination

This LSI has programming/erasing programs and they can be downloaded to the on-chip RAM. The on-chip program to be downloaded is selected by setting the corresponding bits in the programming/erasing interface register. The download destination can be specified by FTDAR.

2. Download of on-chip program

The on-chip program is automatically downloaded by setting the SCO bit in the flash key code register (FKEY) and the flash code control and status register (FCCS), which are programming/erasing interface registers.

The user MAT is replaced to the embedded program storage area when downloading. Since the flash memory cannot be read when programming/erasing, the procedure program, which is working from download to completion of programming/erasing, must be executed in a space other than the flash memory to be programmed/erased (for example, on-chip RAM).

Since the result of download is returned to the programming/erasing interface parameters, whether the normal download is executed or not can be confirmed.

3. Initialization of programming/erasing

The operating frequency is set before execution of programming/erasing. This setting is performed by using the programming/erasing interface parameters.

4. Programming/erasing execution

To program or erase, the FLSHE bit in system control register 2 (SYSCR2) must be set to 1 and the user program mode must be entered.

The program data/programming destination address is specified in 128-byte units when programming.

The block to be erased is specified in erase-block units when erasing.

These specifications are set by using the programming/erasing interface parameters and the on-chip program is initiated. The on-chip program is executed by using the JSR or BSR instruction to perform the subroutine call of the specified address in the on-chip RAM. The execution result is returned to the programming/erasing interface parameters.

The area to be programmed must be erased in advance when programming flash memory.

All interrupts are prohibited during programming and erasing. Interrupts must not occur in the user system.

5. When programming/erasing is executed consecutively

When the processing is not ended by the 128-byte programming or one-block erasure, the program address/data and erase-block number must be updated and consecutive programming/erasing is required.

Since the downloaded on-chip program is left in the on-chip RAM after the processing, download and initialization are not required when the same processing is executed consecutively.

17.22.8 Pin Configuration

Flash memory is controlled by the pin as shown in table 17.47.

Table 17.47 Pin Configuration

Pin Name	Abbreviation	Input/Output	Function
Reset	$\overline{\text{RES}}$	Input	Reset
Mode 2	MD2	Input	Sets operating mode of this LSI
Mode 1	MD1	Input	Sets operating mode of this LSI
Mode 0	MD0	Input	Sets operating mode of this LSI
Port 66	P66	Input	Sets operating mode of this LSI in PROM Mode
Port 65	P65	Input	Sets operating mode of this LSI in PROM Mode
Port 64	P64	Input	Sets operating mode of this LSI in PROM Mode
Transmit data	TxD1	Output	Serial transmit data output
Receive data	RxD1	Input	Serial receive data input

Note: For the pin configuration in PROM mode, see section 17.28, PROM Mode.

17.22.9 Register Configuration

(1) Registers

The registers/parameters which control flash memory when the on-chip flash memory is valid are shown in table 17.48.

To access any of the flash memory control registers except RAMER, the FLSHE bit in SYSCR2 must be set to 1 in a mode in which flash memory is enabled.

There are several operating modes for accessing flash memory, for example, read mode/program mode.

There are two memory MATs: user MAT and user boot MAT. The dedicated registers/parameters are allocated for each operating mode and MAT selection. The correspondence of operating modes and registers/parameters for use is shown in table 17.49.

Table 17.48 (1) Register Configuration

Name	Abbreviation	R/W	Initial Value	Address
Flash code control status register	FCCS	R, W ^{*1}	H'00 H'80	H'FFC4
Flash program code select register	FPCS	R/W	H'00	H'FFC5
Flash erase code select register	FECS	R/W	H'00	H'FFC6
Flash key code register	FKEY	R/W	H'00	H'FFC8
Flash MAT select register	FMATS	R/W	H'00 ^{*2} H'AA ^{*2}	H'FFC9
Flash transfer destination address register	FTDAR	R/W	H'00	H'FFCA
System control register 2	SYSCR2 ^{*3}	R/W	H'00	H'FF42
RAM emulation register	RAMER	R/W	H'00	H'FEDB

- Notes: 1. The bits except the SCO bit are read-only bits. The SCO bit is a programming-only bit. (The value which can be read is always 0.)
2. The initial value at initiation in user mode or user program mode is H'00. The initial value at initiation in user boot mode is H'AA.
3. SYSCR2 is dedicated to the F-ZTAT versions.

Table 17.48 (2) Parameter Configuration

Name	Abbreviation	R/W	Initial Value	Address
Download pass/fail result	DPFR	R/W	Undefined	On-chip RAM*
Flash pass/fail result	FPFR	R/W	Undefined	R0L of CPU
Flash multipurpose address area	FMPAR	R/W	Undefined	ER1 of CPU
Flash multipurpose data destination area	FMPDR	R/W	Undefined	ER0 of CPU
Flash erase block select	FEBS	R/W	Undefined	ER0 of CPU
Flash program and erase frequency control	FPEFEQ	R/W	Undefined	ER0 of CPU

Note: * One byte of the start address in the on-chip RAM area specified by FTDAR is valid.

Table 17.49 Register/Parameter and Target Mode

		Download	Initiali- zation	Program- ming	Erasure	Read	RAM Emulation
Programming/ erasing interface registers	FCCS	○	—	—	—	—	—
	FPCS	○	—	—	—	—	—
	PECS	○	—	—	—	—	—
	FKEY	○	—	○	○	—	—
	FMATS	—	—	○ *1	○ *1	○ *2	—
Programming/ erasing interface parameter	FPFR	○	○	○	○	—	—
	FPEFEQ	—	○	—	—	—	—
	FMPAR	—	—	○	—	—	—
	FMPDR	—	—	○	—	—	—
	FEBS	—	—	—	○	—	—
RAM emulation	RAMER	—	—	—	—	—	○

- Notes: 1. The setting is required when programming or erasing user MAT in user boot mode.
 2. The setting may be required according to the combination of initiation mode and read target MAT.

17.23 Register Description of Flash Memory

17.23.1 Programming/Erasing Interface Register

The programming/erasing interface registers are as described below. They are all 8-bit registers that can be accessed in byte. Except for the FLER bit in FCCS, these registers are initialized at a power-on reset, in hardware standby mode, or in software standby mode. The FLER bit is not initialized in software standby mode.

(1) Flash Code Control and Status Register (FCCS)

FCCS is configured by bits which request the error occurrence during programming or erasing flash memory and the download of on-chip program.

Bit	:	7	6	5	4	3	2	1	0
		—	—	—	FLER	—	—	—	SCO
Initial value	:	1	0	0	0	0	0	0	0
R/W	:	R	R	R	R	R	R	R	(R)/W

Bit 7—Reserved: This bit is always read as 1. The write value should always be 1.

Bits 6 and 5—Reserved: These bits are always read as 0. The write value should always be 0.

Bit 4—Flash Memory Error (FLER): Indicates an error occurs during programming and erasing flash memory.

When FLER is set to 1, flash memory enters the error protection state.

This bit is initialized at a power-on reset or in hardware standby mode.

When FLER is set to 1, high voltage is applied to the internal flash memory. To reduce the damage to flash memory, the reset must be released after the reset period of 100 μ s which is longer than normal.

Bit 4

FLER	Description
0	Flash memory operates normally (Initial value) Programming/erasing protection for flash memory (error protection) is invalid. [Clearing condition] At a power-on reset or in hardware standby mode
1	Indicates an error occurs during programming/erasing flash memory. Programming/erasing protection for flash memory (error protection) is valid. [Setting condition] See section 17.25.3, Error Protection.

Bits 3 to 1—Reserved: These bits are always read as 0. The write value should always be 0.

Bit 0—Source Program Copy Operation (SCO): Requests the on-chip programming/erasing program to be downloaded to the on-chip RAM.

When this bit is set to 1, the on-chip program which is selected by FPCS/FECS is automatically downloaded in the on-chip RAM area specified by FTDAR.

In order to set this bit to 1, RAM emulation state must be canceled, H'A5 must be written to FKEY, and this operation must be in the on-chip RAM.

Four NOP instructions must be executed immediately after setting this bit to 1.

Since this bit is cleared to 0 when download is completed, this bit cannot be read as 1.

All interrupts are prohibited during programming and erasing. Interrupts must not occur in the user system.

Bit 0

SCO	Description
0	Download of the on-chip programming/erasing program to the on-chip RAM is not executed (Initial value) [Clear condition] When download is completed
1	Request that the on-chip programming/erasing program is downloaded to the on-chip RAM is occurred [Set conditions] When all of the following conditions are satisfied and 1 is written to this bit <ul style="list-style-type: none"> • FKEY is written to H'A5 • During execution in the on-chip RAM • Not in RAM emulation mode (RAMS in RAMER = 0)

(2) Flash Program Code Select Register (FPCS)

FPCS selects the on-chip programming program to be downloaded.

Bit	:	7	6	5	4	3	2	1	0
		—	—	—	—	—	—	—	PPVS
Initial value :		0	0	0	0	0	0	0	0
R/W	:	R	R	R	R	R	R	R	R/W

Bits 7 to 1—Reserved: These bits are always read as 0. The write value should always be 0.

Bit 0—Program Pulse Verify (PPVS): Selects the programming program.

Bit 0

PPVS	Description
0	On-chip programming program is not selected (Initial value) [Clear condition] When transfer is completed
1	On-chip programming program is selected

(3) Flash Erase Code Select Register (FECS)

FECS selects download of the on-chip erasing program.

Bit	:	7	6	5	4	3	2	1	0
		—	—	—	—	—	—	—	EPVB
Initial value :		0	0	0	0	0	0	0	0
R/W	:	R	R	R	R	R	R	R	R/W

Bits 7 to 1—Reserved: These bits are always read as 0. The write value should always be 0.

Bit 0—Erase Pulse Verify Block (EPVB): Selects the erasing program.

Bit 0

EPVB	Description
0	On-chip erasing program is not selected (Initial value) [Clear condition] When transfer is completed
1	On-chip erasing program is selected

(4) Flash Key Code Register (FKEY)

FKEY is a register for software protection that enables download of on-chip program and programming/erasing of flash memory. Before setting the SCO bit to 1 in order to download on-chip program or executing the downloaded programming/erasing program, these processing cannot be executed if the key code is not written.

Bit	:	7	6	5	4	3	2	1	0
		K7	K6	K5	K4	K3	K2	K1	K0
Initial value	:	0	0	0	0	0	0	0	0
R/W	:	R/W	R/W	R/W	R/W	R/W	R/W	R/W	R/W

Bits 7 to 0—Key Code (K7 to K0): Only when H'A5 is written, writing to the SCO bit is valid. When the value other than H'A5 is written to FKEY, 1 cannot be written to the SCO bit. Therefore downloading to the on-chip RAM cannot be executed.

Only when H'5A is written, programming/erasing can be executed. Even if the on-chip programming/erasing program is executed, flash memory cannot be programmed or erased when the value other than H'5A is written to FKEY.

Bits 7 to 0

K7 to K0	Description
H'A5	Writing to the SCO bit is enabled (The SCO bit cannot be set by the value other than H'A5.)
H'5A	Programming/erasing is enabled (The value other than H'5A is in software protection state.)
H'00	Initial value

(5) Flash MAT Select Register (FMATS)

FMATS specifies whether user MAT or user boot MAT is selected.

Bit	:	7	6	5	4	3	2	1	0									
		<table border="1" style="width: 100%; border-collapse: collapse;"> <tr> <td style="padding: 2px;">MS7</td> <td style="padding: 2px;">MS6</td> <td style="padding: 2px;">MS5</td> <td style="padding: 2px;">MS4</td> <td style="padding: 2px;">MS3</td> <td style="padding: 2px;">MS2</td> <td style="padding: 2px;">MS1</td> <td style="padding: 2px;">MS0</td> </tr> </table>								MS7	MS6	MS5	MS4	MS3	MS2	MS1	MS0	
MS7	MS6	MS5	MS4	MS3	MS2	MS1	MS0											
Initial value :		0	0	0	0	0	0	0	0	(When not in user boot mode)								
Initial value :		1	0	1	0	1	0	1	0	(When in user boot mode)								
R/W	:	R/W	R/W	R/W	R/W	R/W	R/W	R/W	R/W									

Bits 7 to 0—MAT Select (MS7 to MS0): These bits are in user-MAT selection state when the value other than H'AA is written and in user-boot-MAT selection state when H'AA is written.

The MAT is switched by writing the value in FMATS.

When the MAT is switched, follow section 17.27, Switching between User MAT and User Boot MAT. (The user boot MAT cannot be programmed in user programming mode if user boot MAT is selected by FMATS. The user boot MAT must be programmed in boot mode or in PROM mode.)

Bits 7 to 0**MS7 to MS0 Description**

H'AA	The user boot MAT is selected (in user-MAT selection state when the value of these bits are other than H'AA) Initial value when these bits are initiated in user boot mode.
H'00	Initial value when these bits are initiated in a mode except for user boot mode (in user-MAT selection state)

[Programmable condition] These bits are in the execution state in the on-chip RAM.

(6) Flash Transfer Destination Address Register (FTDAR)

FTDAR specifies the on-chip RAM address to which the on-chip program is downloaded. Make settings for FTDAR before writing 1 to the SCO bit in FCCS. The initial value is H'00 which points to the start address (H'FFBC00) in on-chip RAM.

Bit	:	7	6	5	4	3	2	1	0
		TDER	TDA6	TDA5	TDA4	TDA3	TDA2	TDA1	TDA0
Initial value :		0	0	0	0	0	0	0	0
R/W	:	R/W	R/W	R/W	R/W	R/W	R/W	R/W	R/W

Bit 7—Transfer Destination Address Setting Error: This bit is set to 1 when there is an error in the download start address set by bits 6 to 0 (TDA6 to TDA0). Whether the address setting is erroneous or not is judged by checking whether the setting of TDA6 to TDA0 is between the range of H'00 and H'03 after setting the SCO bit in FCCS to 1 and performing download. Before setting the SCO bit to 1 be sure to set the FTDAR value between H'00 to H'03 as well as clearing this bit to 0.

Bit 7

TDER	Description (Return Value after Download)
0	Setting of TDA6 to TDA0 is normal (Initial value)
1	Setting of TDER and TDA4 to TDA0 is H'04 to H'FF and download has been aborted

Bits 6 to 0—Transfer Destination Address (TDA6 to TDA0): These bits specify the download start address. A value from H'00 to H'03 can be set to specify the download start address in on-chip RAM in 4-kbyte units.

A value from H'04 to H'7F cannot be set. If such a value is set, the TDER bit (bit 7) in this register is set to 1 to prevent download from being executed.

Bits 6 to 0

TDA6 to TDA0	Description
H'00	Download start address is set to H'FFBC00
H'01	Download start address is set to H'FFCC00
H'02	Download start address is set to H'FFDC00
H'03	Download start address is set to H'FFEC00
H'04 to H'7F	Setting prohibited. If this value is set, the TDER bit (bit 7) is set to 1 to abort the download processing.

17.23.2 Programming/Erasing Interface Parameter

The programming/erasing interface parameter specifies the operating frequency, storage place for program data, programming destination address, and erase block and exchanges the processing result for the downloaded on-chip program. This parameter uses the general registers of the CPU (ER0 and ER1) or the on-chip RAM area. The initial value is undefined at a power-on reset or in hardware standby mode.

When download, initialization, or on-chip program is executed, registers of the CPU except for ER0 and ER1 are stored. The return value of the processing result is written in R0L. Since the stack area is used for storing the registers except for ER0 and ER1, the stack area must be saved at the processing start. (A maximum size of a stack area to be used is 128 bytes.)

The programming/erasing interface parameter is used in the following four items.

- (1) Download control
- (2) Initialization before programming or erasing
- (3) Programming
- (4) Erasing

These items use different parameters. The correspondence table is shown in table 17.50.

Here the FPFR parameter returns the results of initialization processing, programming processing, or erasing processing, but the meaning of the bits differs depending on the type of processing. For details, refer to the FPFR descriptions for the individual processes.

Table 17.50 Usable Parameters and Target Modes

Name of Parameter	Abbreviation	Download	Initialization	Programming	Erasure	R/W	Initial Value	Allocation
Download pass/fail result	DPFR	○	—	—	—	R/W	Undefined	On-chip RAM*
Flash pass/fail result	FPFR	—	○	○	○	R/W	Undefined	R0L of CPU
Flash programming/erasing frequency control	FPEFEQ	—	○	—	—	R/W	Undefined	ER0 of CPU
Flash multipurpose address area	FMPAR	—	—	○	—	R/W	Undefined	ER1 of CPU
Flash multi-purpose data destination area	FMPDR	—	—	○	—	R/W	Undefined	ER0 of CPU
Flash erase block select	FEBS	—	—	—	○	R/W	Undefined	ER0 of CPU

Note: * One byte of start address of download destination specified by FTDAR

(1) Download Control

The on-chip program is automatically downloaded by setting the SCO bit to 1. The on-chip RAM area to be downloaded is the area as much as 4 kbytes starting from the start address specified by FTDAR. For the address map of the on-chip RAM, see figure 17.69.

The download control is set by using the programming/erasing interface register. The return value is given by the DPFR parameter.

(a) Download pass/fail result parameter (DPFR: one byte of start address of on-chip RAM specified by FTDAR)

This parameter indicates the return value of the download result. The value of this parameter can be used to determine if downloading is executed or not. Since the confirmation whether the SCO bit is set to 1 is difficult, the certain determination must be performed by setting one byte of the start address of the on-chip RAM area specified by FTDAR to a value other than the return value of download (for example, H'FF) before the download start (before setting the SCO bit to 1). Refer to item [e] in the User Program Mode Programming Procedure portion of section 17.24.2, for information on the method for checking the download result.

Bit	:	7	6	5	4	3	2	1	0
		0	0	0	0	0	SS	FK	SF
Initial value :		—	—	—	—	—	—	—	—
R/W	:	—	—	—	—	—	R/W	R/W	R/W

Bits 7 to 3—Reserved: Return 0.

Bit 2—Source Select Error Detect (SS): The on-chip program which can be downloaded can be specified only one type. When more than two types of the program are selected, the program is not selected, or the program is selected without mapping, error is occurred.

Bit 2

SS	Description
0	Download program can be selected normally
1	Download error is occurred (Multi-selection or program which is not mapped is selected)

Bit 1—Flash Key Register Error Detect (FK): Returns the check result whether the value of FKEY is set to H'A5.

Bit 1

FK	Description
0	FKEY setting is normal (FKEY = H'A5)
1	Setting value of FKEY becomes error (FKEY = value other than H'A5)

Bit 0—Success/Fail (SF): Returns the result whether download is ended normally or not. The judgement result whether program that is downloaded to the on-chip RAM is read back and then transferred to the on-chip RAM is returned.

Bit 0

SF	Description
0	Downloading on-chip program is ended normally (no error)
1	Downloading on-chip program is ended abnormally (error occurs)

(2) Programming/Erasing Initialization

The on-chip programming/erasing program to be downloaded includes the initialization program.

The specified period pulse must be applied when programming or erasing. The specified pulse width is made by the method in which wait loop is configured by the CPU instruction. The operating frequency of the CPU must be set.

The initial program is set as a parameter of the programming/erasing program which has downloaded these settings.

(a) Flash programming/erasing frequency parameter (FPEFEQ: general register ER0 of CPU)

This parameter sets the operating frequency of the CPU.

The operating frequency range of this LSI is 2 MHz to 25 MHz.

Bit	:	31	30	29	28	27	26	25	24
		0	0	0	0	0	0	0	0

Initial value : — — — — — — — —

R/W : — — — — — — — —

Bit	:	23	22	21	20	19	18	17	16
		0	0	0	0	0	0	0	0

Initial value : — — — — — — — —

R/W : — — — — — — — —

Bit	:	15	14	13	12	11	10	9	8
		F15	F14	F13	F12	F11	F10	F9	F8

Initial value : — — — — — — — —

R/W : R/W R/W R/W R/W R/W R/W R/W R/W

Bit	:	7	6	5	4	3	2	1	0
		F7	F6	F5	F4	F3	F2	F1	F0

Initial value : — — — — — — — —

R/W : R/W R/W R/W R/W R/W R/W R/W R/W

Bits 31 to 16—Reserved: Only 0 may be written to these bits.

Bits 15 to 0—Frequency Set (F15 to F0): Set the operating frequency of the CPU. The setting value must be calculated as the following methods.

1. The operating frequency which is shown in MHz units must be rounded in a number to three decimal places and be shown in a number of two decimal places.
2. The centuplicated value is converted to the binary digit and is written to the FPEFEQ parameter (general register ER0). For example, when the operating frequency of the CPU is 25.000 MHz, the value is as follows.
 - The number to three decimal places of 25.000 is rounded and the value is thus 25.00.
 - The formula that $25.00 \times 100 = 2500$ is converted to the binary digit and b'0000,1001,1100,0100 (H'09C4) is set to ER0.

(b) Flash pass/fail parameter (FPFR: general register R0L of CPU)

This is the return value indicating the initialization result.

Bit	:	7	6	5	4	3	2	1	0
		0	0	0	0	0	0	FQ	SF
Initial value :		—	—	—	—	—	—	—	—
R/W	:	—	—	—	—	—	—	R/W	R/W

Bits 7 to 2—Reserved: Return 0.

Bit 1—Frequency Error Detect (FQ): Returns the check result whether the specified operating frequency of the CPU is in the range of the supported operating frequency.

Bit 1

FQ	Description
0	Setting of operating frequency is normal
1	Setting of operating frequency is abnormal

Bit 0—Success/Fail (SF): Indicates whether initialization is completed normally.

Bit 0

SF	Description
0	Initialization is ended normally (no error)
1	Initialization is ended abnormally (error occurs)

(3) Programming Execution

When flash memory is programmed, the programming destination address on the user MAT must be passed to the programming program in which the program data is downloaded.

1. The start address of the programming destination on the user MAT is set in general register ER1 of the CPU. This parameter is called FMPAR (flash multipurpose address area parameter).
Since the program data is always in 128-byte units, the lower eight bits (A7 to A0) must be H'00 or H'80 as the boundary of the programming start address on the user MAT.
2. The program data for the user MAT must be prepared in the consecutive area. The program data must be in the consecutive space which can be accessed by using the MOV.B instruction of the CPU and is not the flash memory space.
When data to be programmed does not satisfy 128 bytes, the 128-byte program data must be prepared by embedding the dummy code (H'FF).
The start address of the area in which the prepared program data is stored must be set in general register ER0. This parameter is called FMPDR (flash multipurpose data destination area parameter).

For details on the programming procedure, see section 17.24.2, User Program Mode.

(a) Flash multipurpose address area parameter (FMPAR: general register ER1 of CPU)

This parameter indicates the start address of the programming destination on the user MAT.

When an address in an area other than the flash memory space is set, an error occurs.

The start address of the programming destination must be at the 128-byte boundary. If this boundary condition is not satisfied, an error occurs. The error occurrence is indicated by the WA bit (bit 1) in FPCR.

FMPAR

Bit	:	31	30	29	28	27	26	25	24
		MOA31	MOA30	MOA29	MOA28	MOA27	MOA26	MOA25	MOA24
Initial value :		—	—	—	—	—	—	—	—
R/W	:	R/W	R/W	R/W	R/W	R/W	R/W	R/W	R/W
Bit	:	23	22	21	20	19	18	17	16
		MOA23	MOA22	MOA21	MOA20	MOA19	MOA18	MOA17	MOA16
Initial value :		—	—	—	—	—	—	—	—
R/W	:	R/W	R/W	R/W	R/W	R/W	R/W	R/W	R/W
Bit	:	15	14	13	12	11	10	9	8
		MOA15	MOA14	MOA13	MOA12	MOA11	MOA10	MOA9	MOA8
Initial value :		—	—	—	—	—	—	—	—
R/W	:	R/W	R/W	R/W	R/W	R/W	R/W	R/W	R/W
Bit	:	7	6	5	4	3	2	1	0
		MOA7	MOA6	MOA5	MOA4	MOA3	MOA2	MOA1	MOA0
Initial value :		—	—	—	—	—	—	—	—
R/W	:	R/W	R/W	R/W	R/W	R/W	R/W	R/W	R/W

Bits 31 to 0—MOA31 to MOA0: Store the start address of the programming destination on the user MAT. The consecutive 128-byte programming is executed starting from the specified start address of the user MAT. Therefore, the specified programming start address becomes a 128-byte boundary and MOA6 to MOA0 are always 0.

(b) Flash multipurpose data destination parameter (FMPDR: general register ER0 of CPU):

This parameter indicates the start address in the area which stores the data to be programmed in the user MAT. When the storage destination of the program data is in flash memory, an error occurs. The error occurrence is indicated by the WD bit (bit 2) in FPPR.

FMPDR

Bit	:	31	30	29	28	27	26	25	24
		MOD31	MOD30	MOD29	MOD28	MOD27	MOD26	MOD25	MOD24
Initial value :		—	—	—	—	—	—	—	—
R/W	:	R/W	R/W	R/W	R/W	R/W	R/W	R/W	R/W
Bit	:	23	22	21	20	19	18	17	16
		MOD23	MOD22	MOD21	MOD20	MOD19	MOD18	MOD17	MOD16
Initial value :		—	—	—	—	—	—	—	—
R/W	:	R/W	R/W	R/W	R/W	R/W	R/W	R/W	R/W
Bit	:	15	14	13	12	11	10	9	8
		MOD15	MOD14	MOD13	MOD12	MOD11	MOD10	MOD9	MOD8
Initial value :		—	—	—	—	—	—	—	—
R/W	:	R/W	R/W	R/W	R/W	R/W	R/W	R/W	R/W
Bit	:	7	6	5	4	3	2	1	0
		MOD7	MOD6	MOD5	MOD4	MOD3	MOD2	MOD1	MOD0
Initial value :		—	—	—	—	—	—	—	—
R/W	:	R/W	R/W	R/W	R/W	R/W	R/W	R/W	R/W

Bits 31 to 0—MOD31 to MOD0: Store the start address of the area which stores the program data for the user MAT. The consecutive 128-byte data is programmed to the user MAT starting from the specified start address.

(c) Flash pass/fail parameter (FPFR: general register R0L of CPU)

An explanation of FPFR as the return value indicating the programming result is provided here.

Bit	:	7	6	5	4	3	2	1	0
		0	MD	EE	FK	0	WD	WA	SF
Initial value :		—	—	—	—	—	—	—	—
R/W	:	—	R/W	R/W	R/W	—	R/W	R/W	R/W

Bit 7—Reserved: Returns 0.

Bit 6—Programming Mode Related Setting Error Detect (MD): Returns the check result of whether the error protection state has been entered.

If the error protection state has been entered, 1 is written to this bit. This state can be confirmed by checking bit 4, FLER, in the FCCS register. For conditions to enter the error protection state, see section 17.25.3, Error Protection.

Bit 6

MD	Description
0	FLER setting is normal (FLER = 0)
1	FLER = 1, and programming cannot be performed

Bit 5—Programming Execution Error Detect (EE): 1 is returned to this bit when the specified data could not be written because the user MAT was not erased.

If this bit is set to 1, there is a high possibility that the user MAT is partially rewritten. In this case, after removing the error factor, erase the user MAT.

If FMATS is set to H'AA and the user boot MAT is selected, an error occurs when programming is performed. In this case, both the user MAT and user boot MAT are not rewritten.

Programming of the user boot MAT should be performed in the boot mode or PROM mode.

Bit 5

EE	Description
0	Programming has ended normally
1	Programming has ended abnormally (programming result is not guaranteed)

Bit 4—Flash Key Register Error Detect (FK): Returns the check result of the value of FKEY before the start of the programming processing.

Bit 4

FK	Description
0	FKEY setting is normal (FKEY = H'5A)
1	FKEY setting is error (FKEY = value other than H'5A)

Bit 3—Reserved: Returns 0.

Bit 2—Write Data Address Detect (WD): When flash memory area is specified as the start address of the storage destination of the program data, an error occurs.

Bit 2

WD	Description
0	Setting of write data address is normal
1	Setting of write data address is abnormal

Bit 1—Write Address Error Detect (WA): When the following area is specified as the start address of the programming destination, an error occurs.

1. If the start address is outside the flash memory area
2. If the specified address is not a 128-byte boundary (A6 to A0 are not 0)

Bit 1

WA	Description
0	Setting of programming destination address is normal
1	Setting of programming destination address is abnormal

Bit 0—Success/Fail (SF): Indicates whether the program processing is ended normally or not.

Bit 0

SF	Description
0	Programming is ended normally (no error)
1	Programming is ended abnormally (error occurs)

(4) Erasure Execution

When flash memory is erased, the erase-block number on the user MAT must be passed to the erasing program which is downloaded. This is set to the FEBS parameter (general register ER0).

One block is specified from the block number 0 to 15.

For details on the erasing processing procedure, see section 17.24.2, User Program Mode.

(a) Flash erase block select parameter (FEBS: general register ER0 of CPU)

This parameter specifies the erase-block number. The several block numbers cannot be specified.

Bit	:	31	30	29	28	27	26	25	24
		0	0	0	0	0	0	0	0

Initial value :	—	—	—	—	—	—	—	—	—
R/W :	R/W	R/W	R/W	R/W	R/W	R/W	R/W	R/W	R/W

Bit	:	23	22	21	20	19	18	17	16
		0	0	0	0	0	0	0	0

Initial value :	—	—	—	—	—	—	—	—	—
R/W :	R/W	R/W	R/W	R/W	R/W	R/W	R/W	R/W	R/W

Bit	:	15	14	13	12	11	10	9	8
		0	0	0	0	0	0	0	0

Initial value :	—	—	—	—	—	—	—	—	—
R/W :	R/W	R/W	R/W	R/W	R/W	R/W	R/W	R/W	R/W

Bit	:	7	6	5	4	3	2	1	0
		EB7	EB6	EB5	EB4	EB3	EB2	EB1	EB0

Initial value :	—	—	—	—	—	—	—	—	—
R/W :	R/W	R/W	R/W	R/W	R/W	R/W	R/W	R/W	R/W

Bits 31 to 8—Reserved: Only 0 may be written to these bits.

Bits 7 to 0—Erase Block (EB7 to EB0): Set the erase-block number in the range from 0 to 15. 0 corresponds to the EB0 block and 15 corresponds to the EB15 block. An error occurs when the number other than 0 to 15 is set.

(b) Flash pass/fail parameter (FPFR: general register R0L of CPU)

An explanation of FPFR as the return value indicating the erase result is provided here.

Bit	:	7	6	5	4	3	2	1	0
		0	MD	EE	FK	EB	0	0	SF
Initial value :		—	—	—	—	—	—	—	—
R/W	:	—	R/W	R/W	R/W	R/W	—	—	R/W

Bit 7—Reserved: Returns 0.

Bit 6—Erasure Mode Related Setting Error Detect (MD): Returns the check result of whether the error protection state has been entered.

If the error protection state has been entered, 1 is written to this bit. This state can be confirmed by checking bit 4, FLER, in the FCCS register. For conditions to enter the error protection state, see section 17.25.3, Error Protection.

Bit 6

MD	Description
0	FLER settings is normal (FLER = 0)
1	FLER = 1, and erasure cannot be performed

Bit 5—Erasure Execution Error Detect (EE): 1 is returned to this bit when the user MAT could not be erased.

If this bit is set to 1, there is a high possibility that the user MAT is partially erased. In this case, after removing the error factor, erase the user MAT.

If FMATS is set to H'AA and the user boot MAT is selected, an error occurs when erasure is performed. In this case, both the user MAT and user boot MAT are not erased.

Erasing of the user boot MAT should be performed in the boot mode or PROM mode.

Bit 5

EE	Description
0	Erasure has ended normally
1	Erasure has ended abnormally (erasure result is not guaranteed)

Bit 4—Flash Key Register Error Detect (FK): Returns the check result of FKEY value before start of the erasing processing.

Bit 4

FK	Description
0	FKEY setting is normal (FKEY = H'5A)
1	FKEY setting is error (FKEY = value other than H'5A)

Bit 3—Erase Block Select Error Detect (EB): Returns the check result whether the specified erase-block number is in the block range of the user MAT.

Bit 3

EB	Description
0	Setting of erase-block number is normal
1	Setting of erase-block number is abnormal

Bits 2 and 1—Reserved: Return 0.

Bit 0—Success/Fail (SF): Indicates whether the erasing processing is ended normally or not.

Bit 0

SF	Description
0	Erase is ended normally (no error)
1	Erase is ended abnormally (error occurs)

17.23.3 System Control Register 2 (SYSCR2)

Bit	:	7	6	5	4	3	2	1	0
		—	—	—	—	FLSHE	—	—	—
Initial value	:	0	0	0	0	0	0	0	0
R/W	:	—	—	—	—	R/W	—	—	R/W

SYSCR2 is an 8-bit readable/writable register that performs on-chip flash memory control.

SYSCR2 is initialized to H'00 by a reset and in hardware standby mode.

SYSCR2 can only be used in the F-ZTAT versions. In the mask ROM versions this register will return an undefined value if read, and cannot be modified.

Bits 7 to 4—Reserved: These bits cannot be modified and are always read as 0.

Bit 3—Flash Memory Control Register Enable (FLSHE): Controls CPU access to the flash memory control registers (FCCS, FPCS, FECS, FKEY, FMATS, FTDAR). Writing 1 to the FLSHE bit enables the flash memory control registers to be read and written to. Clearing FLSHE to 0 designates these registers as unselected (the register contents are retained).

Bit 3

FLSHE	Description
0	Flash control registers are not selected for addresses H'FFFC4 to H'FFFCF (Initial value)
1	Flash control registers are selected for addresses H'FFFC4 to H'FFFCF

Bits 2 and 1—Reserved: These bits cannot be modified and are always read as 0.

Bit 0—Reserved: Only 0 may be written to this bit.

17.23.4 RAM Emulation Register (RAMER)

Bit	:	7	6	5	4	3	2	1	0
		—	—	—	—	RAMS	RAM2	RAM1	RAM0
Initial value :		0	0	0	0	0	0	0	0
R/W	:	—	—	—	—	R/W	R/W	R/W	R/W

RAMER specifies the area of flash memory to be overlapped with part of RAM when emulating real-time flash memory programming. RAMER is initialized to H'00 by a reset and in hardware standby mode. It is not initialized in software standby mode. RAMER settings should be made in user mode or user program mode.

Flash memory area divisions are shown in table 17.51. To ensure correct operation of the emulation function, the ROM for which RAM emulation is performed should not be accessed immediately after this register has been modified. Normal execution of an access immediately after register modification is not guaranteed.

Bits 7 to 4—Reserved: These bits cannot be modified and are always read as 0.

Bit 3—RAM Select (RAMS): Specifies selection or non-selection of flash memory emulation in RAM. When RAMS = 1, all flash memory blocks are program/erase-protected.

Bit 3

RAMS	Description
0	Emulation not selected Program/erase-protection of all flash memory blocks is disabled (Initial value)
1	Emulation selected Program/erase-protection of all flash memory blocks is enabled

Bits 2 to 0—Flash Memory Area Selection (RAM2 to RAM0): These bits are used together with bit 3 to select the flash memory area to be overlapped with RAM (see table 17.51).

Table 17.51 Flash Memory Area Divisions

RAM Area	Block Name	RAMS	RAM2	RAM1	RAM0
H'FFDC00 to H'FFE000	RAM area, 4 kbytes	0	×	×	×
H'000000 to H'000FFF	EB0 (4 kbytes)	1	0	0	0
H'001000 to H'001FFF	EB1 (4 kbytes)	1	0	0	1
H'002000 to H'002FFF	EB2 (4 kbytes)	1	0	1	0
H'003000 to H'003FFF	EB3 (4 kbytes)	1	0	1	1
H'004000 to H'004FFF	EB4 (4 kbytes)	1	1	0	0
H'005000 to H'005FFF	EB5 (4 kbytes)	1	1	0	1
H'006000 to H'006FFF	EB6 (4 kbytes)	1	1	1	0
H'007000 to H'007FFF	EB7 (4 kbytes)	1	1	1	1

×: Don't care

17.24 On-Board Programming Mode

When the pin is set in on-board programming mode and the reset start is executed, the on-board programming state that can program/erase the on-chip flash memory is entered. On-board programming mode has three operating modes: user programming mode, user boot mode, and boot mode.

Table 17.52 lists the pin setting for entering each mode. For details on the state transition of each mode for flash memory, see figure 17.61.

Table 17.52 Setting On-Board Programming Modes

MCU Mode	Mode	Pins		
	CPU Operating Modes/Description	MD2	MD1	MD0
User boot mode	Advanced single-chip mode	0	0	1
Boot mode	Advanced expanded mode with on-chip ROM enabled	0	1	0
	Advanced single-chip mode			1
User program mode*	Advanced expanded mode with on-chip ROM enabled	1	1	0
	Advanced single-chip mode			1

Note: * Normally, user mode should be used. Before downloading a program/erase program, set the FLSHE bit to 1 to switch to the user program mode.

17.24.1 Boot Mode

Boot mode executes programming/erasing user MAT and user boot MAT by means of the control command and program data transmitted from the host using the on-chip SCI. The tool for transmitting the control command and program data must be prepared in the host. The SCI communication mode is set to asynchronous mode. When reset start is executed after this LSI's pin is set in boot mode, the boot program in the microcomputer is initiated. After the SCI bit rate is automatically adjusted, the communication with the host is executed by means of the control command method.

The system configuration diagram in boot mode is shown in figure 17.65. For details on the pin setting in boot mode, see table 17.52. The NMI and other interrupts are ignored in boot mode.

Make sure the NMI and other interrupts do not occur in the user system.

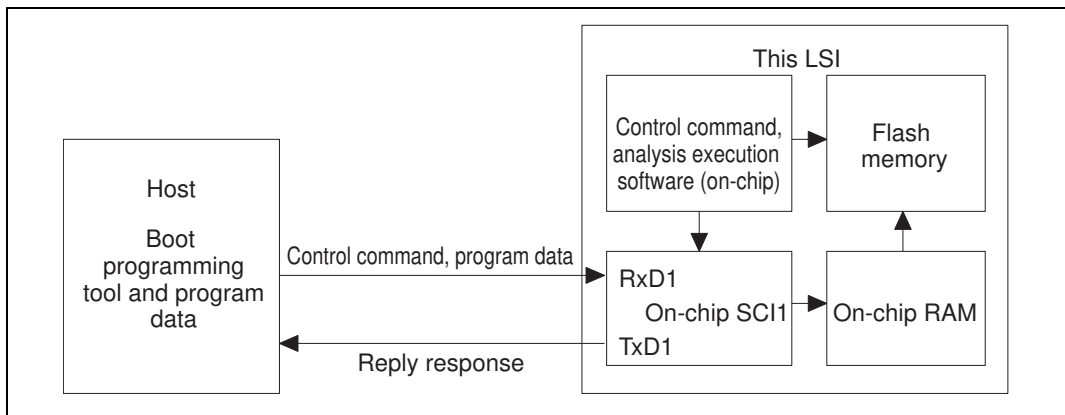

Figure 17.65 System Configuration in Boot Mode

SCI Interface Setting by Host: When boot mode is initiated, this LSI measures the low period of asynchronous SCI-communication data (H'00), which is transmitted consecutively by the host. The SCI transmit/receive format is set to 8-bit data, 1 stop bit, and no parity. This LSI calculates the bit rate of transmission by the host by means of the measured low period and transmits the bit adjustment end sign (1 byte of H'00) to the host. The host must confirm that this bit adjustment end sign (H'00) has been received normally and transmits 1 byte of H'55 to this LSI. When reception is not executed normally, boot mode is initiated again (reset) and the operation described above must be executed. The bit rate between the host and this LSI is not matched by the bit rate of transmission by the host and system clock frequency of this LSI. To operate the SCI normally, the transfer bit rate of the host must be set to 9,600 bps or 19,200 bps.

The system clock frequency which can automatically adjust the transfer bit rate of the host and the bit rate of this LSI is shown in table 17.53. Boot mode must be initiated in the range of this system clock.

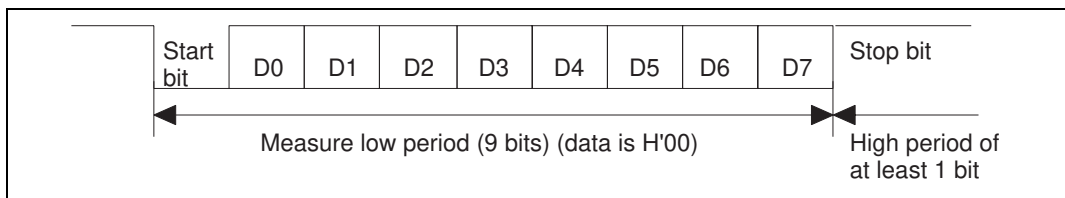

Figure 17.66 Automatic Adjustment Operation of SCI Bit Rate

Table 17.53 System Clock Frequency that can Automatically Adjust Bit Rate of This LSI

Bit rate of host	System Clock Frequency Which Can Automatically Adjust Bit Rate of This LSI
19,200 bps	16 MHz to 25 MHz
9,600 bps	8 MHz to 25 MHz

State Transition: The overview of the state transition after boot mode is initiated is shown in figure 17.67. For details on boot mode, refer to section 17.29.1, Serial Communications Interface Specification for Boot Mode.

[1] Bit rate adjustment

After boot mode is initiated, the bit rate of the SCI interface is adjusted with that of the host.

[2] Waiting for inquiry set command

For inquiries about user-MAT size and configuration, MAT start address, and support state, the required information is transmitted to the host.

[3] Automatic erasure of all user MAT and user boot MAT

After inquiries have finished, all user MAT and user boot MAT are automatically erased.

[4] Waiting for programming/erasing command

- When the program preparation notice is received, the state for waiting program data is entered. The programming start address and program data must be transmitted following the programming command. When programming is finished, the programming start address must be set to H'FFFFFFFF and transmitted. Then the state for waiting program data is returned to the state of programming/erasing command wait.
- When the erasure preparation notice is received, the state for waiting erase-block data is entered. The erase-block number must be transmitted following the erasing command. When the erasure is finished, the erase-block number must be set to H'FF and transmitted. Then the state for waiting erase-block data is returned to the state for waiting programming/erasing command. The erasure must be executed when reset start is not executed and the specified block is programmed after programming is executed in boot mode. When programming can be executed by only one operation, all blocks are erased before the state for waiting programming/erasing/other command is entered. The erasing operation is not required.
- There are many commands other than programming/erasing. Examples are sum check, blank check (erasure check), and memory read of the user MAT/user boot MAT and acquisition of current status information.

Note that memory read of the user MAT/user boot MAT can only read the program data after all user MAT/user boot MAT has automatically been erased.

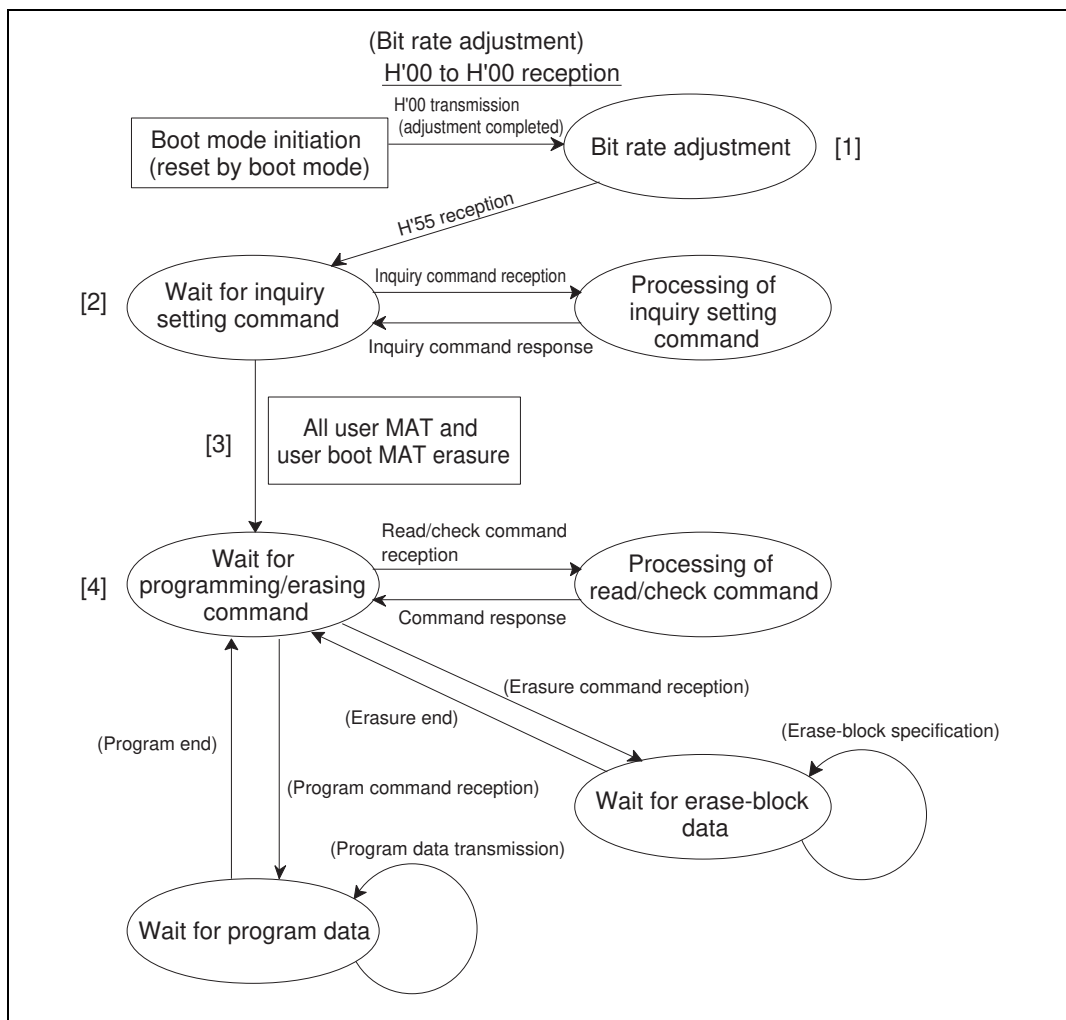

Figure 17.67 Overview of Boot Mode State Transition

17.24.2 User Program Mode

The user MAT can be programmed/erased in user program mode. (The user boot MAT cannot be programmed/erased.)

Programming/erasing is executed by downloading the program in the microcomputer.

The programming/erasing overview flow is shown in figure 17.68.

High voltage is applied to internal flash memory during the programming/erasing processing. Therefore, transition to reset or hardware standby must not be executed. Doing so may cause damage or destroy flash memory. If reset is executed accidentally, reset must be released after the reset input period, which is longer than normal 100 μ s.

For information on the programming procedure refer to "Programming Procedure in User Program Mode", and for information on the erasing procedure refer to "Erasing Procedure in User Program Mode", below.

For the overview of a processing that repeats erasing and programming by downloading the programming program and the erasing program in separate on-chip ROM areas using FTDAR, see "Erasing and Programming Procedure in User Program Mode" which appears later in this section.

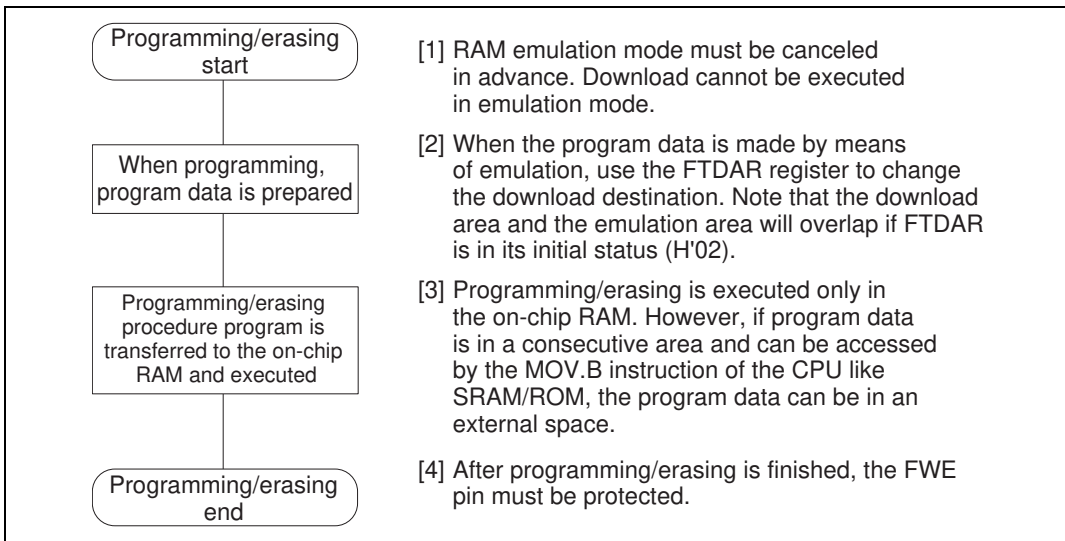

Figure 17.68 Programming/Erasing Overview Flow

On-Chip RAM Address Map when Programming/Erasing Is Executed: Parts of the procedure program that are made by the user, like download request, programming/erasing procedure, and judgement of the result, must be executed in the on-chip RAM. The on-chip program that is to be downloaded is all in the on-chip RAM. Note that area in the on-chip RAM must be controlled so that these parts do not overlap.

Figure 17.69 shows the program area to be downloaded.

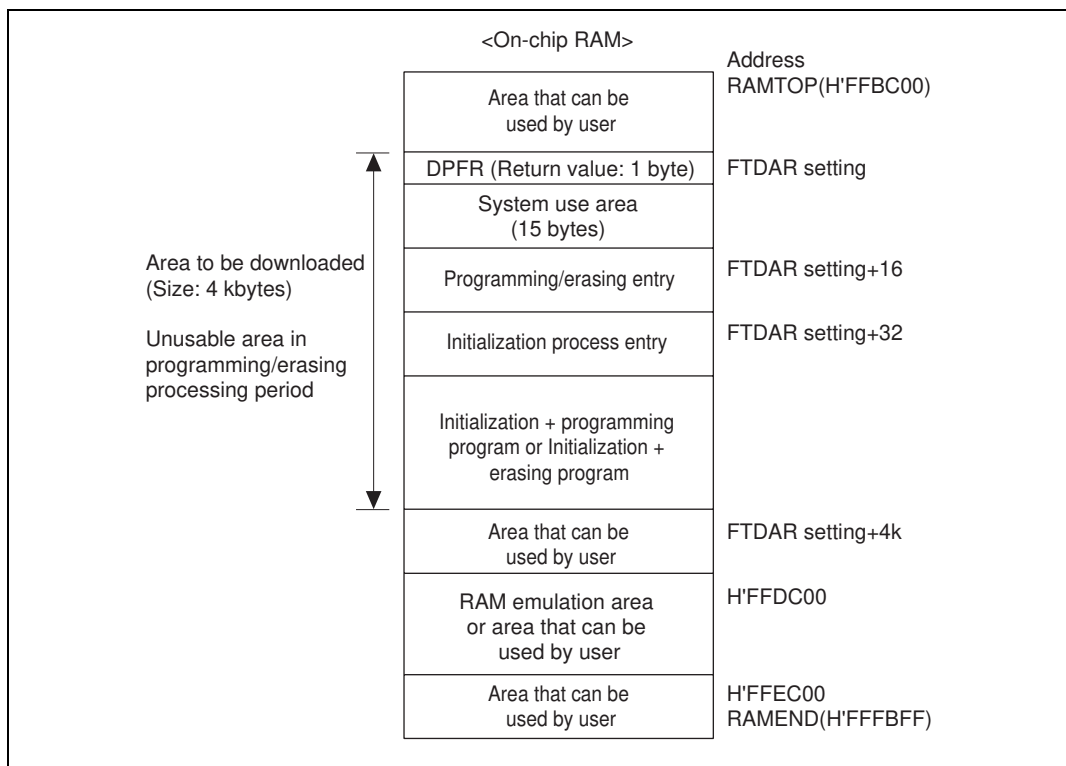

Figure 17.69 RAM Map when Programming/Erasing is Executed

Programming Procedure in User Program Mode: The procedures for download, initialization, and programming are shown in figure 17.70.

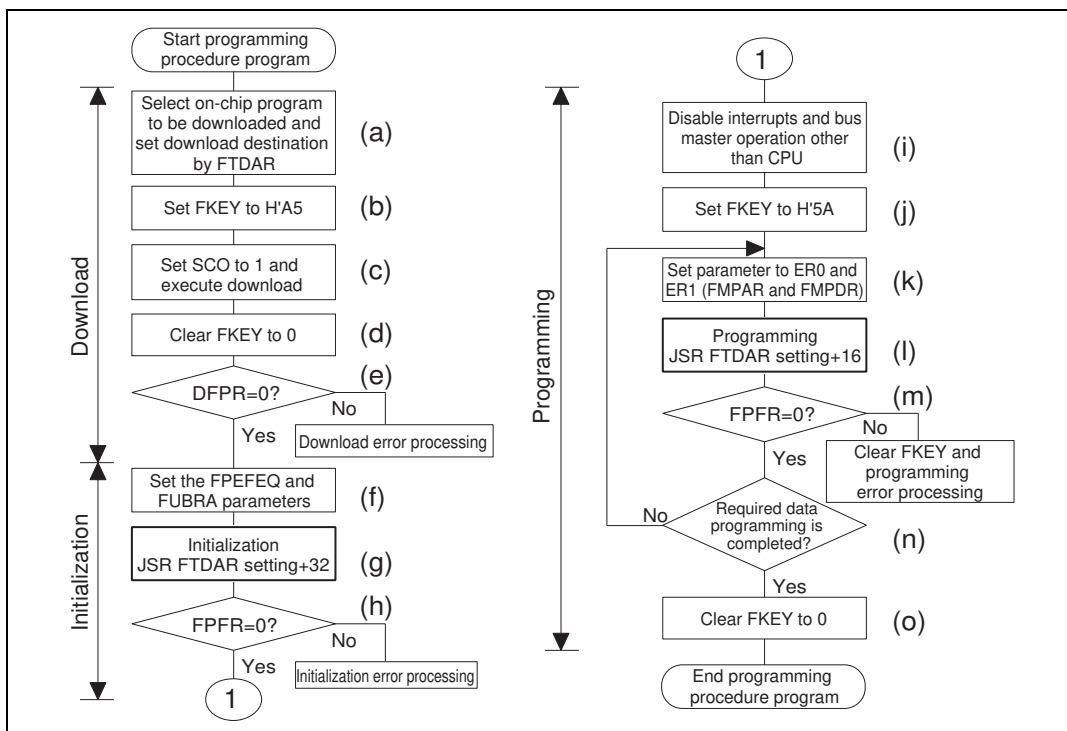

Figure 17.70 Programming Procedure

The procedure program must be executed in an area other than the flash memory to be programmed. Especially the part where the SCO bit in FCCS is set to 1 for downloading must be executed in the on-chip RAM.

The area that can be executed in the steps of the user procedure program (on-chip RAM, user MAT, and external space) is shown in section 17.29.3, Procedure Program and Storable Area for Programming Data.

The following description assumes the area to be programmed on the user MAT is erased and program data is prepared in the consecutive area. When erasing is not executed, erasing is executed before writing.

128-byte programming is performed in one program processing. When more than 128-byte programming is performed, programming destination address/program data parameter is updated in 128-byte units and programming is repeated.

When less than 128-byte programming is performed, data must total 128 bytes by adding the invalid data. If the invalid data to be added is H'FF, the program processing period can be shorted.

[1] Select the on-chip program to be downloaded and the download destination.

When the PPVS bit of FPCS is set to 1, the programming program is selected.

Several programming/erasing programs cannot be selected at one time. If several programs are set, download is not performed and a download error is returned to the source select error detect (SS) bit in the DPFR parameter.

Specify the start address of the download destination by FTDAR.

[2] Program H'A5 in FKEY

If H'A5 is not written to FKEY for protection, 1 cannot be written to the SCO bit for download request.

[3] 1 is written to the SCO bit of FCCS and then download is executed.

To write 1 to the SCO bit, the following conditions must be satisfied.

- RAM emulation mode is canceled.
- H'A5 is written to FKEY.
- The SCO bit writing is executed in the on-chip RAM.

When the SCO bit is set to 1, download is started automatically. When the SCO bit is returned to the user procedure program, the SCO is cleared to 0. Therefore, the SCO bit cannot be confirmed to be 1 in the user procedure program.

The download result can be confirmed only by the return value of the DPFR parameter. Before the SCO bit is set to 1, incorrect judgement must be prevented by setting the DPFR parameter, that is one byte of the start address of the on-chip RAM area specified by FTDAR, to a value other than the return value (H'FF).

When download is executed, particular interrupt processing, which is accompanied by the bank switch as described below, is performed as an internal microcomputer processing. Four NOP instructions are executed immediately after the instructions that set the SCO bit to 1.

- (a) The user-MAT space is switched to the on-chip program storage area.
 - (b) After the selection condition of the download program and the address set in FTDAR are checked, the transfer processing is executed starting from the on-chip RAM address specified by FTDAR.
 - (c) The SCO bits in FPCS, FECS, and FCCS are cleared to 0.
 - (d) The return value is set to the DPFR parameter.
 - (e) After the on-chip program storage area is returned to the user-MAT space, the user procedure program is returned.
- In the download processing, the values are stored in the general registers other than ER0 and ER1 of the CPU.

- No interrupts are accepted during download processing. However, interrupt requests are held, so when processing returns to the user procedure program and interrupts are generated. When the level-detection interrupt requests are to be held, interrupts must be put until the download is ended.
- When hardware standby mode is entered during download processing, the normal download cannot be guaranteed in the on-chip RAM. Therefore, download must be executed again.
- Since a stack area of a maximum 128 bytes is used, the area must be saved before setting the SCO bit to 1.
- If flash memory is accessed by the DTC or $\overline{\text{BREQ}}$ during downloading, the operation cannot be guaranteed. Therefore, access by the DTC or $\overline{\text{BREQ}}$ must not be executed.

[4] FKEY is cleared to H'00 for protection.

[5] The value of the DPFR parameter must be checked and the download result must be confirmed.

A recommended procedure for confirming the download result is shown below.

- Check the value of the DPFR parameter (one byte of start address of the download destination specified by FTDAR). If the value is H'00, download has been performed normally. If the value is not H'00, the source that caused download to fail can be investigated by the description below.
- If the value of the DPFR parameter is the same as before downloading (e.g. H'FF), the address setting of the download destination in FTDAR may be abnormal. In this case, confirm the setting of the TDER bit (bit 7) in FTDAR.
- If the value of the DPFR parameter is different from before downloading, check the SS bit (bit 2) and the FK bit (bit 1) in the DPFR parameter to ensure that the download program selection and FKEY register setting were normal, respectively.

[6] The operating frequency is set to the FPEFEQ parameter for initialization.

- The current frequency of the CPU clock is set to the FPEFEQ parameter (general register: ER0).

The settable range of the FPEFEQ parameter is 2 MHz to 25 MHz.

When the frequency is set out of this range, an error is returned to the FPFR parameter of the initialization program and initialization is not performed. For details on the frequency setting, see the description in 17.23.2 (2) (a) Flash programming/erasing frequency parameter (FPEFEQ: general register ER0 of CPU).

[7] Initialization

When a programming program is downloaded, the initialization program is also downloaded to the on-chip RAM. There is an entry point of the initialization program in the area from (download start address set by FTDAR) + 32 bytes. The subroutine is called and initialization is executed by using the following steps.

MOV.L	#DLTOP+32,ER2	; Set entry address to ER2
JSR	@ER2	; Call initialization routine
NOP		

- The general registers other than ER0 and ER1 are saved in the initialization program.
- R0L is a return value of the FPFR parameter.
- Since the stack area is used in the initialization program, a stack area of a maximum 128 bytes must be saved in RAM.
- Interrupts can be accepted during the execution of the initialization program. The program storage area and stack area in the on-chip RAM and register values must not be destroyed.

[8] The return value in the initialization program, FPFR (general register R0L) is judged.

[9] All interrupts and the use of a bus master other than the CPU are prohibited.

The specified voltage is applied for the specified time when programming or erasing. If interrupts occur or the bus mastership is moved to other than the CPU during this time, more than the specified voltage will be applied and flash memory may be damaged. Therefore, interrupts and movement of bus mastership to DTC or $\overline{\text{BREQ}}$ other than the CPU are prohibited.

The interrupt processing prohibition is set up by setting the bit 7 (I) in the condition code register (CCR) of the CPU to b'1. Then interrupts other than NMI are held and are not executed.

The NMI interrupts must not occur in the user system.

The interrupts that are held must be processed in executed after all program processing.

When the bus mastership is moved to DTC or $\overline{\text{BREQ}}$ or DRAM refresh except for the CPU, the error protection state is entered. Therefore, reservation of bus mastership by DTC or $\overline{\text{BREQ}}$ is prohibited.

[10] FKEY must be set to H'5A and the user MAT must be prepared for programming.

[11] The parameter which is required for programming is set.

The start address of the programming destination of the user MAT (FMPAR) is set to general register ER1. The start address of the program data storage area (FMPDR) is set to general register ER0.

- Example of the FMPAR setting

FMPAR specifies the programming destination address. When an address other than one in the user MAT area is specified, even if the programming program is executed, programming is not executed and an error is returned to the return value parameter FPFR. Since the unit is 128 bytes, the lower eight bits (A7 to A0) must be in the 128-byte boundary of H'00 or H'80.

- Example of the FMPDR setting

When the storage destination of the program data is flash memory, even if the program execution routine is executed, programming is not executed and an error is returned to the FPFR parameter. In this case, the program data must be transferred to the on-chip RAM and then programming must be executed.

[12] Programming

There is an entry point of the programming program in the area from (download start address set by FTDAR) + 16 bytes of on-chip RAM. The subroutine is called and programming is executed by using the following steps.

MOV.L	#DLTOP+16,ER2	; Set entry address to ER2
JSR	@ER2	; Call programming routine
NOP		

- The general registers other than ER0 and ER1 are saved in the programming program.
- R0 is a return value of the FPFR parameter.
- Since the stack area is used in the programming program, a stack area of a maximum 128 bytes must be reserved in RAM

[13] The return value in the programming program, FPFR (general register R0L) is judged.

[14] Determine whether programming of the necessary data has finished.

If more than 128 bytes of data are to be programmed, specify FMPAR and FMPDR in 128-byte units, and repeat steps (l) to (n). Increment the programming destination address by 128 bytes and update the programming data pointer correctly. If an address which has already been programmed is written to again, not only will a programming error occur, but also flash memory will be damaged.

[15] After programming finishes, clear FKEY and specify software protection.

If this LSI is restarted by a power-on reset immediately after user MAT programming has finished, secure a reset period (period of $\overline{RES} = 0$) that is at least as long as normal 100 μs .

Erasing Procedure in User Program Mode: The procedures for download, initialization, and erasing are shown in figure 17.71.

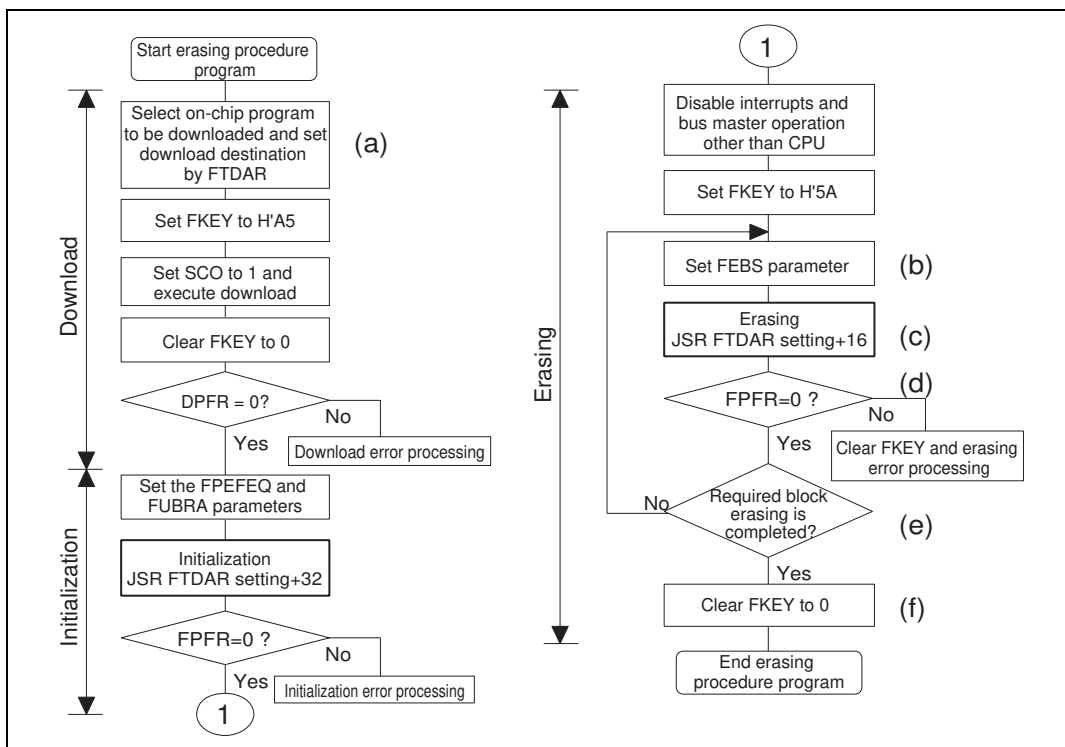

Figure 17.71 Erasing Procedure

The procedure program must be executed in an area other than the user MAT to be erased. Especially the part where the SCO bit in FCCS is set to 1 for downloading must be executed in on-chip RAM.

The area that can be executed in the steps of the user procedure program (on-chip RAM, user MAT, and external space) is shown in section 17.29.3, Procedure Program and Storable Area for Programming Data.

For the downloaded on-chip program area, refer to the RAM map for programming/erasing in figure 17.69.

A single divided block is erased by one erasing processing. For block divisions, refer to figure 17.63, Block Division of User MAT. To erase two or more blocks, update the erase block number and perform the erasing processing for each block.

[1] Select the on-chip program to be downloaded

Set the EPVB bit in FECS to 1.

Several programming/erasing programs cannot be selected at one time. If several programs are set, download is not performed and a download error is returned to the source select error detect (SS) bit in the DPFR parameter.

The procedures to be carried out after setting FKEY, e.g. download and initialization, are the same as those in the programming procedure. For details, refer to Programming Procedure in User Program Mode in section 17.24.2, User Program Mode.

[2] Set the FEBS parameter necessary for erasure

Set the erase block number of the user MAT in the flash erase block select parameter FEBS (general register ER0). If a value other than an erase block number of the user MAT is set, no block is erased even though the erasing program is executed, and an error is returned to the return value parameter FPFR.

[3] Erasure

Similar to as in programming, there is an entry point of the erasing program in the area from (download start address set by FTDAR) + 16 bytes of on-chip RAM. The subroutine is called and erasing is executed by using the following steps.

```
MOV.L #DLTOP+16,ER2      ; Set entry address to ER2
JSR   @ER2                ; Call erasing routine
NOP
```

- The general registers other than ER0 and ER1 are saved in the erasing program.
- R0 is a return value of the FPFR parameter.
- Since the stack area is used in the erasing program, a stack area of a maximum 128 bytes must be reserved in RAM

[4] The return value in the erasing program, FPFR (general register R0L) is judged.

[5] Determine whether erasure of the necessary blocks has finished.

If more than one block is to be erased, update the FEBS parameter and repeat steps (b) to (e). Blocks that have already been erased can be erased again.

[6] After erasure finishes, clear FKEY and specify software protection.

If this LSI is restarted by a power-on reset immediately after user MAT erasure has finished, secure a reset period (period of $\overline{\text{RES}} = 0$) that is at least as long as normal 100 μs .

Erasing and Programming Procedure in User Program Mode: By changing the on-chip RAM address of the download destination in FTDAR, the erasing program and programming program can be downloaded to separate on-chip RAM areas.

Figure 17.72 shows an example of repetitively executing RAM emulation, erasing, and programming.

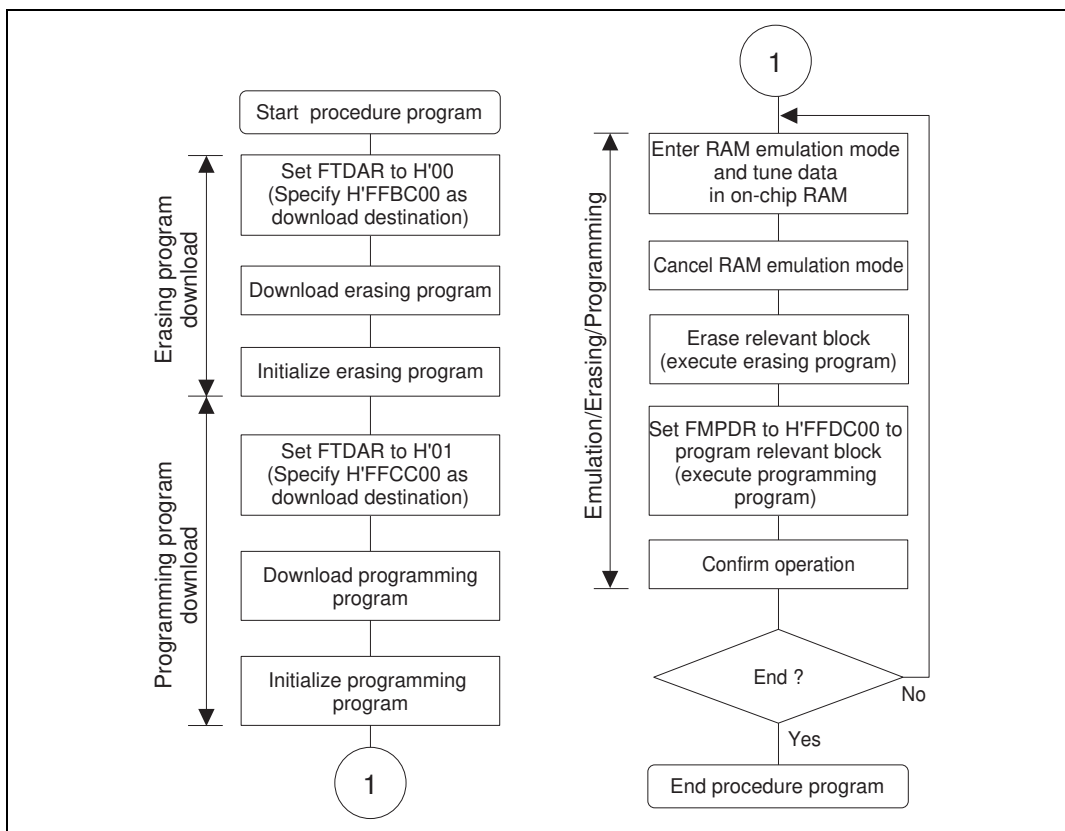

Figure 17.72 Sample Procedure of Repeating RAM Emulation, Erasing, and Programming (Overview)

In the above example, the erasing program and programming program are downloaded to areas excluding the 4 kbytes (H'FFDC00 to H'FFEC00) from H'FFDC00.

Download and initialization are performed only once at the beginning.

In this kind of operation, note the following:

- Be careful not to damage on-chip RAM with overlapped settings.
In addition to the RAM emulation area, erasing program area, and programming program area, areas for the user procedure programs, work area, and stack area are reserved in on-chip RAM. Do not make settings that will overwrite data in these areas.
- Be sure to initialize both the erasing program and programming program.
Initialization by setting the FPEFEQ parameter must be performed for both the erasing program and the programming program. Initialization must be executed for both entry addresses: (download start address for erasing program) + 32 bytes (H'FFBC20 in this example) and (download start address for programming program) + 32 bytes (H'FFCC20 in this example).

17.24.3 User Boot Mode

This LSI has user boot mode which is initiated with different mode pin settings than those in user program mode or boot mode. User boot mode is a user-arbitrary boot mode, unlike boot mode that uses the on-chip SCI.

Only the user MAT can be programmed/erased in user boot mode. Programming/erasing of the user boot MAT is only enabled in boot mode or programmer mode.

User Boot Mode Initiation: For the mode pin settings to start up user boot mode, see table 17.52.

When the reset start is executed in user boot mode, the built-in check routine runs. The user MAT and user boot MAT states are checked by this check routine.

While the check routine is running, NMI and all other interrupts cannot be accepted.

Next, processing starts from the execution start address of the reset vector in the user boot MAT. At this point, H'AA is set to the flash MAT select register FMATS because the execution MAT is the user boot MAT.

User MAT Programming in User Boot Mode: For programming the user MAT in user boot mode, additional processings made by setting FMATS are required: switching from user-boot-MAT selection state to user-MAT selection state, and switching back to user-boot-MAT selection state after programming completes.

Figure 17.73 shows the procedure for programming the user MAT in user boot mode.

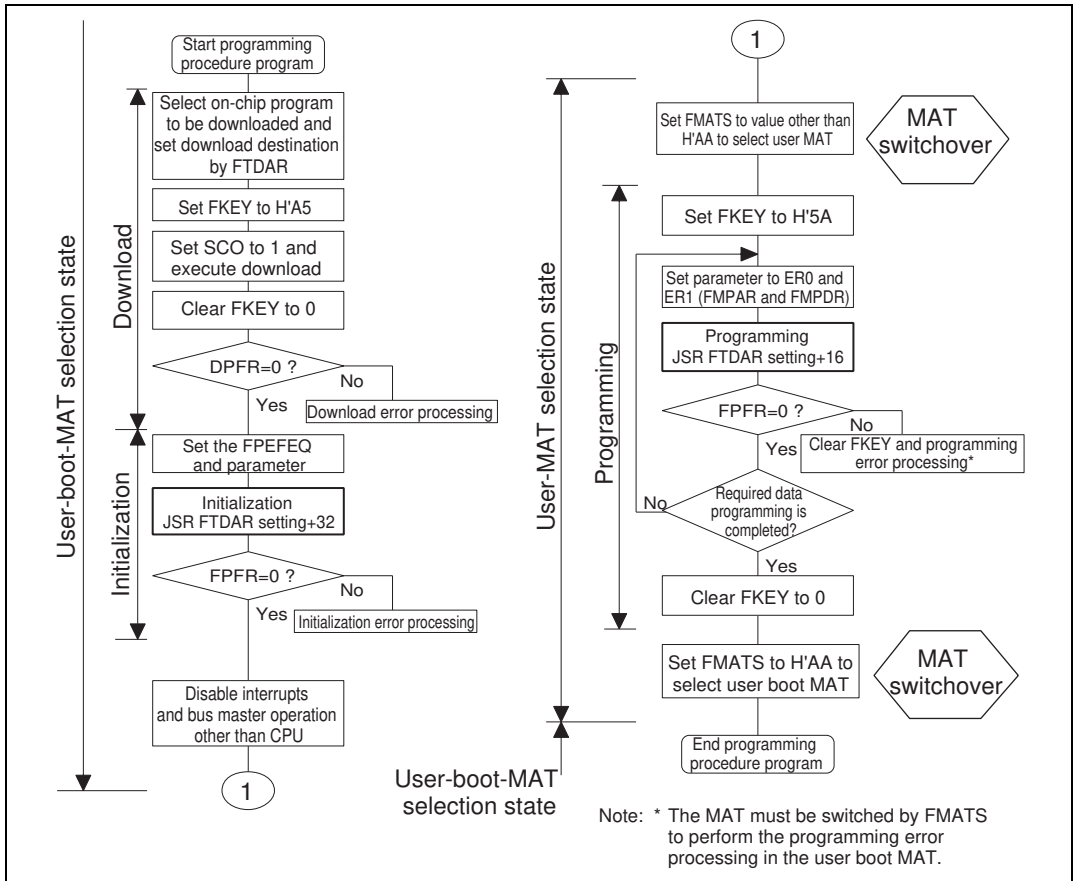

Figure 17.73 Procedure for Programming User MAT in User Boot Mode

The difference between the programming procedures in user program mode and user boot mode is whether the MAT is switched or not as shown in figure 17.73.

In user boot mode, the user boot MAT can be seen in the flash memory space with the user MAT hidden in the background. The user MAT and user boot MAT are switched only while the user MAT is being programmed. Because the user boot MAT is hidden while the user MAT is being programmed, the procedure program must be located in an area other than flash memory. After programming finishes, switch the MATs again to return to the first state.

MAT switchover is enabled by writing a specific value to FMATS. However note that while the MATs are being switched, the LSI is in an unstable state, e.g. access to a MAT is not allowed until MAT switching is completely finished, and if an interrupt occurs, from which MAT the interrupt

vector is read from is undetermined. Perform MAT switching in accordance with the description in section 17.27, Switching between User MAT and User Boot MAT.

Except for MAT switching, the programming procedure is the same as that in user program mode.

The area that can be executed in the steps of the user procedure program (on-chip RAM, user MAT, and external space) is shown in section 17.29.3, Procedure Program and Storable Area for Programming Data.

User MAT Erasing in User Boot Mode: For erasing the user MAT in user boot mode, additional processings made by setting FMATS are required: switching from user-boot-MAT selection state to user-MAT selection state, and switching back to user-boot-MAT selection state after erasing completes.

Figure 17.74 shows the procedure for erasing the user MAT in user boot mode.

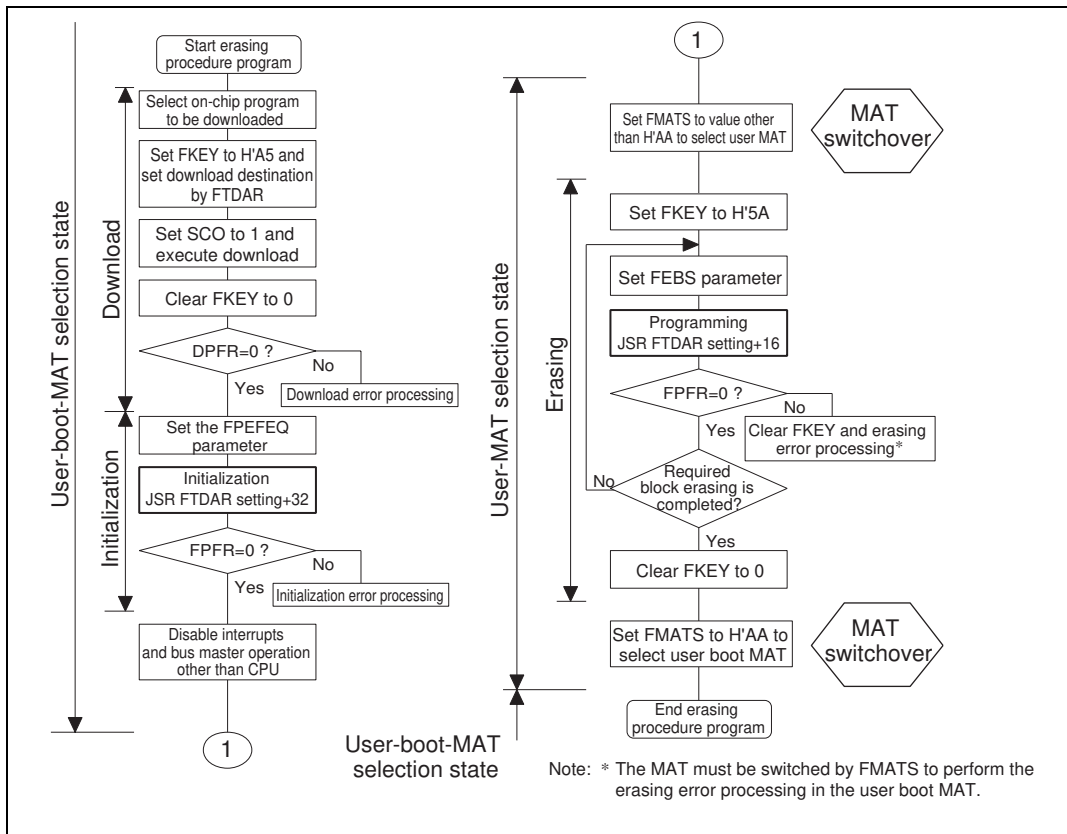

Figure 17.74 Procedure for Erasing User MAT in User Boot Mode

The difference between the erasing procedures in user program mode and user boot mode depends on whether the MAT is switched or not as shown in figure 17.74.

MAT switching is enabled by writing a specific value to FMATS. However note that while the MATs are being switched, the LSI is in an unstable state, e.g. access to a MAT is not allowed until MAT switching is completed finished, and if an interrupt occurs, from which MAT the interrupt vector is read from is undetermined. Perform MAT switching in accordance with the description in section 17.27, Switching between User MAT and User Boot MAT.

Except for MAT switching, the erasing procedure is the same as that in user program mode.

The area that can be executed in the steps of the user procedure program (on-chip RAM, user MAT, and external space) is shown in section 17.29.3, Procedure Program and Storable Area for Programming Data.

17.25 Protection

There are three kinds of flash memory program/erase protection: hardware, software protection, and error protection.

17.25.1 Hardware Protection

Programming and erasing of flash memory is forcibly disabled or suspended by hardware protection. In this state, the downloading of an on-chip program and initialization of the flash memory are possible. However, an activated program for programming or erasure cannot program or erase locations in a user MAT, and the error in programming/erasing is reported in the parameter FPFRR.

Table 17.54 Hardware Protection

Item	Description	Function to Be Protected	
		Download	Program/Erase
Reset/standby protection	<ul style="list-style-type: none"> A power-on reset (including a power-on reset by the WDT) and entry to standby mode reinitialize the program/erase interface register and the device enters a program/erase-protected state. Resetting by means of the $\overline{\text{RES}}$ pin after power is initially supplied will not make the device enter the reset state unless the $\overline{\text{RES}}$ pin is held low until oscillation has stabilized. In the case of a reset during operation, hold the $\overline{\text{RES}}$ pin low for the RES pulse width that is specified in the section on AC characteristics section. If the device is reset during programming or erasure, data values in the flash memory are not guaranteed. In this case, after keeping the $\overline{\text{RES}}$ pin low for at least 100 μs, execute erasure and then execute programming again. 	Yes	Yes

17.25.2 Software Protection

Software protection is set up in any of three ways: by disabling the downloading of on-chip programs for programming and erasing, by means of a key code, and by the RAM-emulation register.

Table 17.55 Software Protection

Item	Description	Function to Be Protected	
		Download	Program/Erase
Protection by the SCO bit	<ul style="list-style-type: none"> Clearing the SCO bit in the FCCS register makes the device enter a program/erase-protected state, and this disables the downloading of the programming/erasing programs. 	○	○
Protection by the FKEY register	<ul style="list-style-type: none"> Downloading and programming/erasing are disabled unless the required key code is written in the FKEY register. Different key codes are used for downloading and for programming/erasing. 	○	○
Emulation protection	<ul style="list-style-type: none"> Setting the RAMS bit in the RAM emulation register (RAMER) makes the device enter a program/erase-protected state. 	○	○

17.25.3 Error Protection

Error protection is a mechanism for aborting programming or erasure when an error occurs, in the form of the microcomputer entering runaway during programming/erasing of the flash memory or operations that are not according to the established procedures for programming/erasing. Aborting programming or erasure in such cases prevents damage to the flash memory due to excessive programming or erasing.

If the microcomputer malfunctions during programming/erasing of the flash memory, the FLER bit in the FCCS register is set to 1 and the device enters the error-protection state, and this aborts the programming or erasure.

The FLER bit is set in the following conditions:

- (1) When an interrupt, such as NMI, has occurred during programming/erasing
- (2) When the relevant block area of flash memory is read during programming/erasing (including a vector read or an instruction fetch)
- (3) When a SLEEP instruction (including software standby mode) is executed during programming/erasing
- (4) When a bus master other than the CPU, such as DTC or $\overline{\text{BREQ}}$, has obtained the bus right during programming/erasing

Error protection is cancelled only by a power-on reset or by hardware-standby mode. Note that the reset should only be released after providing a reset input over a period longer than the normal 100 μs period. Since high voltages are applied during programming/erasing of the flash memory, some voltage may remain after the error-protection state has been entered. For this reason, it is necessary to reduce the risk of damage to the flash memory by extending the reset period so that the charge is released.

The state-transition diagram in figure 17.75 shows transitions to and from the error-protection state.

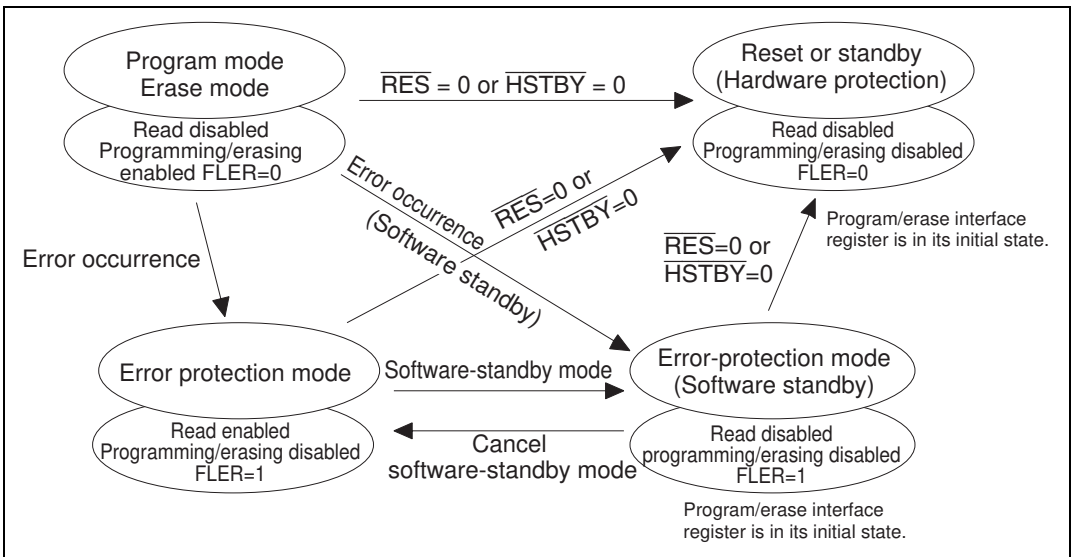

Figure 17.75 Transitions to and from the Error-Protection State

17.26 Flash Memory Emulation in RAM

To provide real-time emulation in RAM of data that is to be written to the flash memory, a part of the RAM can be overlaid on an area of flash memory (user MAT) that has been specified by the RAM emulation register (RAMER). After the RAMER setting is made, the RAM is accessible in both the user MAT area and as the RAM area that has been overlaid on the user MAT area. Such emulation is possible in both user mode and user-program mode.

Figure 17.76 shows an example of the emulation of realtime programming of the user MAT area.

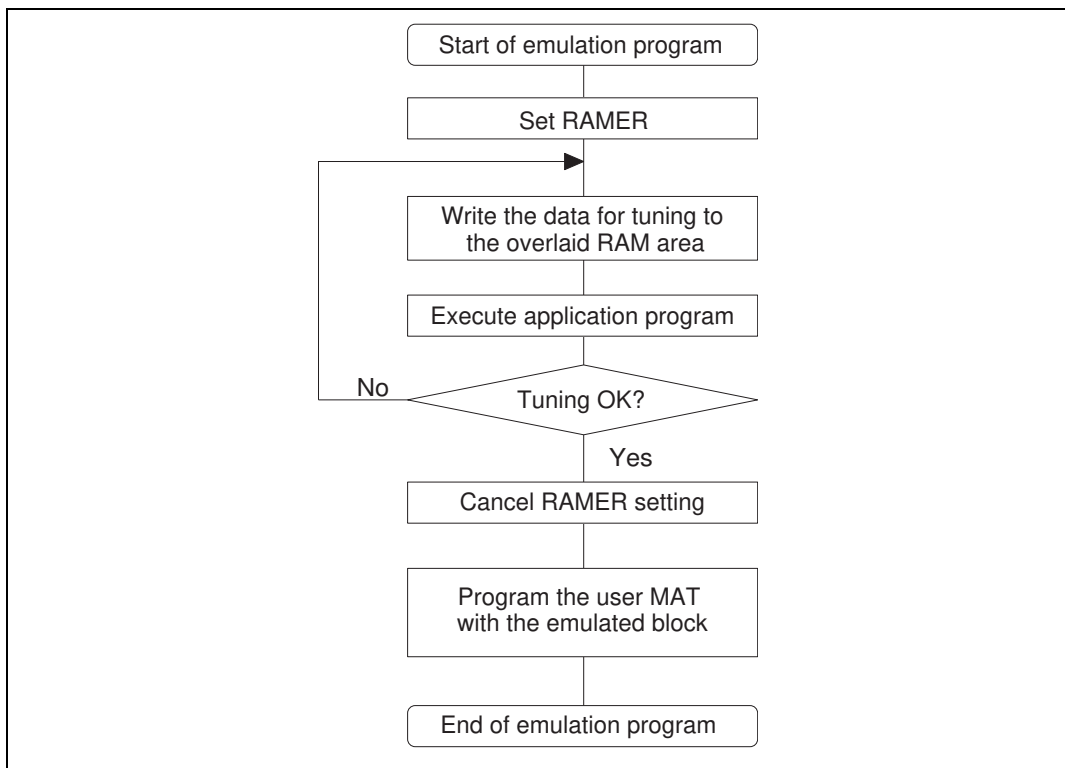

Figure 17.76 Emulation of Flash Memory in RAM

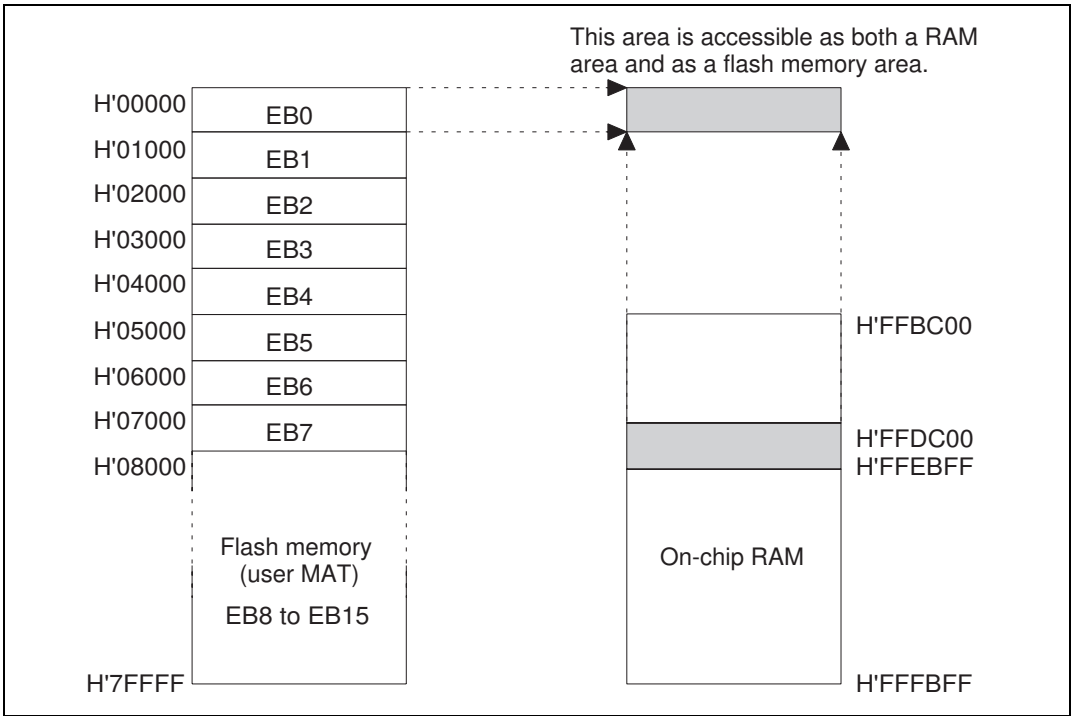

Figure 17.77 Example of a RAM-Overlap Operation

Figure 17.77 shows an example of an overlap on block area EB0 of the flash memory.

Emulation is possible for a single area selected from among the eight areas, from EB0 to EB7, of user MAT bank 0. The area is selected by the setting of the RAM2 to RAM0 bits in the RAMER register.

- (1) To overlap a part of the RAM on area EB0, to allow realtime programming of the data for this area, set the RAMER register's RAMS bit to 1, and each of the RAM2 to RAM0 bits to 0.
- (2) Realtime programming is carried out using the overlaid area of RAM.

In programming or erasing the user MAT, it is necessary to run a program that implements a series of procedural steps, including the downloading of a on-chip program. In this process, set the download area with FTDAR so that the overlaid RAM area and the area where the on-chip program is to be downloaded do not overlap. An FTDAR setting of H'02 will cause part of the tuned data area to overlap with part of the download area. When using the initial setting of FTDAR, the data that is to be programmed must be saved beforehand in an area that is not used by the system.

Figure 17.78 shows an example of programming of the data, after emulation has been completed, to the EB0 area in the user MAT.

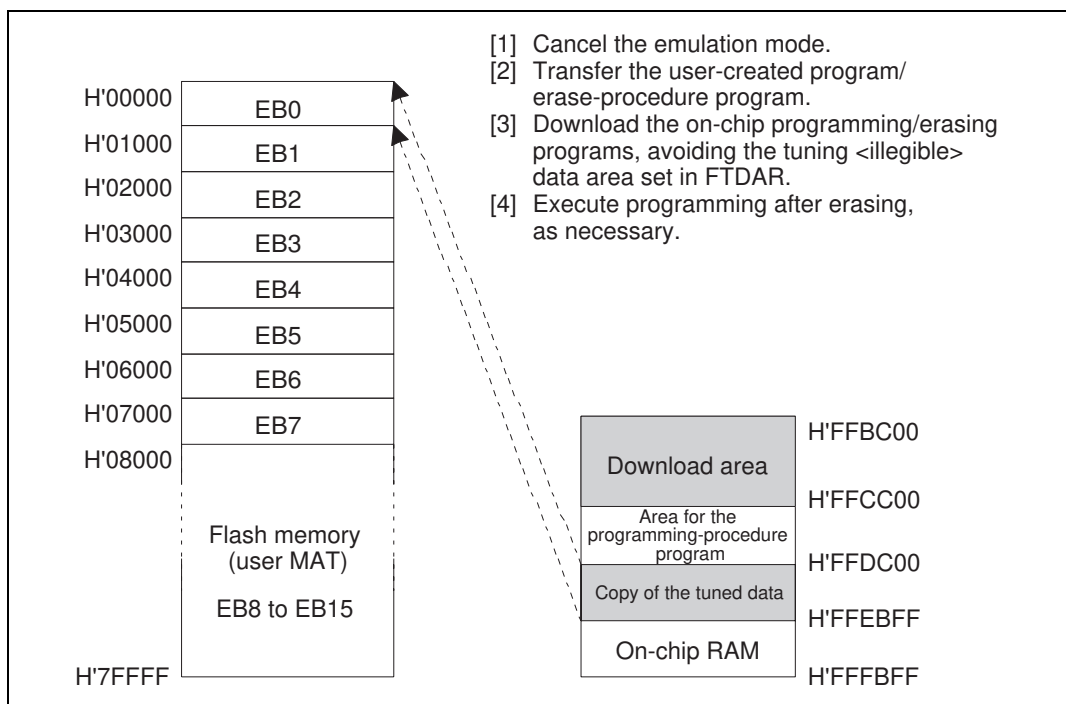

Figure 17.78 Programming of the Data After Tuning

- [1] After the data to be programmed has fixed values, clear the RAMS bit to 0 to cancel the overlap of RAM.
- [2] Transfer the user programming/erasing procedure program to RAM.
- [3] Run the programming/erasing procedure program in RAM and download the on-chip programming/erasing program.
Specify the download start address with FTDAR so that the tuned data area does not overlap with the download area.
- [4] When the EB0 area of the user MAT has not been erased, the programming program will be downloaded after erasure. Set the parameters FMPAR and FMPDR so that the tuned data is designated, and execute programming.

Note: Setting the RAMS bit to 1 puts all the blocks in the flash MAT into a program/erase-protected state regardless of the values of the RAM2 to RAM0 bits (emulation protection). In this state, downloading of the on-chip programs is also disabled, so clear the RAMS bit before actual programming or erasure.

17.27 Switching between User MAT and User Boot MAT

It is possible to alternate between the user MAT and user boot MAT. However, the following procedure is required because these MATs are allocated to address 0.

(Switching to the user boot MAT disables programming and erasing. Programming of the user boot MAT should take place in boot mode or PROM mode.)

- (1) MAT switching by the FMATS register should always be executed from the on-chip RAM.
- (2) To ensure that the MAT that has been switched to is accessible, execute 4 NOP instructions in the on-chip RAM immediately before or after writing to the FMATS register of the on-chip RAM (this prevents access to the flash memory during MAT switching).
- (3) If an interrupt has occurred during switching, there is no guarantee of which memory MAT is being accessed. Always mask the maskable interrupts before switching between MATs. In addition, configure the system so that NMI interrupts do not occur during MAT switching.
- (4) After the MATs have been switched, take care because the interrupt vector table will also have been switched. Methods for processing the same interrupt before and after MAT switching include the following:
 - Prepare the same interrupt processing routines and interrupt vectors in both the user MAT and user boot MAT.
 - Transfer the interrupt processing routines to on-chip RAM beforehand and set the interrupt vectors to the same on-chip RAM addresses for both the user MAT and user boot MAT.
- (5) Memory sizes of the user MAT and user boot MAT are different. When accessing the user boot MAT, do not access addresses above the top of its 8-kbyte memory space. If access goes beyond the 8-kbyte space, the values read are undefined.

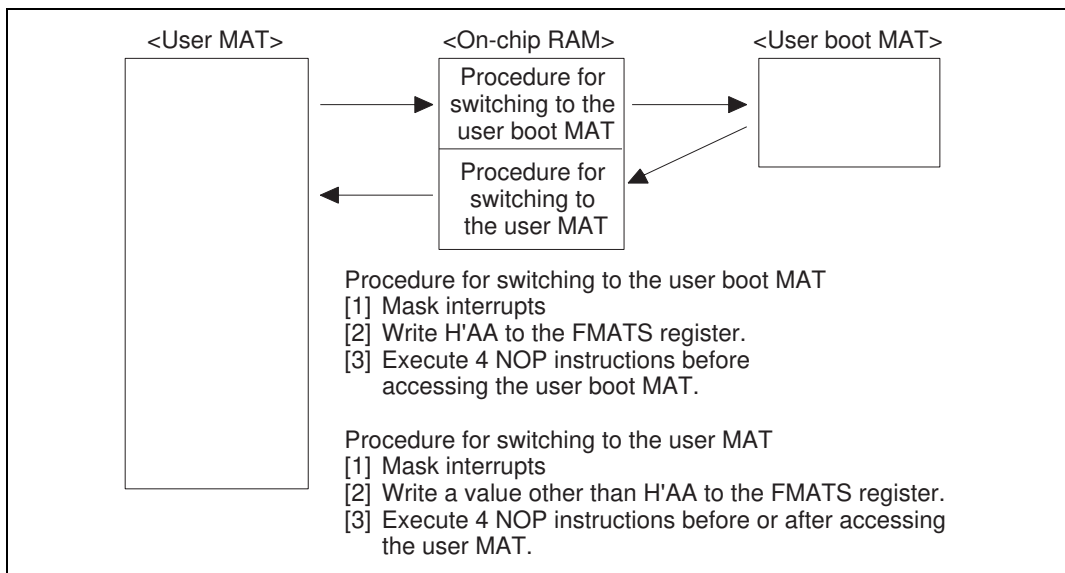

Figure 17.79 Switching between the User MAT and User Boot MAT

17.27.1 Usage Notes

1. Download time of on-chip program

The programming program that includes the initialization routine and the erasing program that includes the initialization routine are each 2 kbytes or less. Accordingly, when the CPU clock frequency is 25 MHz, the download for each program takes approximately 164 μ s at maximum.

2. Write to flash-memory related registers by DTC

While an instruction in on-chip RAM is being executed, the DTC can write to the SCO bit in FCCS that is used for a download request or FMATS that is used for MAT switching. Make sure that these registers are not accidentally written to, otherwise an on-chip program may be downloaded and damage RAM or a MAT switchover may occur and the CPU get out of control. Do not use DTC to program FLASH related registers.

3. Compatibility with programming/erasing program of conventional F-ZTAT H8S microcomputer

A programming/erasing program for flash memory used in the conventional F-ZTAT H8S microcomputer which does not support download of the on-chip program by a SCO transfer request cannot run in this LSI.

Be sure to download the on-chip program to execute programming/erasing of flash memory in this LSI.

4. Monitoring runaway by WDT

Unlike the conventional F-ZTAT H8S microcomputer, no countermeasures are available for a runaway by WDT during programming/erasing by the downloaded on-chip program.

Prepare countermeasures (e.g. use of the user branch routine and periodic timer interrupts) for WDT while taking the programming/erasing time into consideration as required.

17.28 PROM Mode

Along with its on-board programming mode, this LSI also has a PROM mode as a further mode for the writing and erasing of programs and data. In the PROM mode, a general-purpose PROM programmer can freely be used to write programs to the on-chip ROM. Program/erase is possible on the user MAT and user boot MAT. The PROM programmer must support Renesas Technology microcomputers with 512-kbyte flash memory units as a device type.

A status-polling system is adopted for operation in automatic program, automatic erase, and status-read modes. In the status-read mode, details of the system's internal signals are output after execution of automatic programming or automatic erasure. In the PROM mode, provide a 12-MHz input-clock signal.

Table 17.56 PROM Mode Pins

Pin Names	Settings/External Circuit Connection
Mode pins: MD2, MD1, MD0	Low level input to MD2, MD1, and MD0
Mode setting pins: PF2, PF1, PF0	High level input to PF2, low level input to PF1 and PF0
$\overline{\text{STBY}}$ pin	High-level input (do not select hardware standby mode)
$\overline{\text{RES}}$ pin	Reset circuit
XTAL, EXTAL pins	Oscillator circuit
Other pins requiring setting: P23, P25	High-level input to P23, low-level input to P25

17.28.1 Pin Arrangement of the Socket Adapter

Attach the socket adapter to the LSI in the way shown in figure 17.81. This allows conversion to 40 pins. Figure 17.80 shows the memory mapping of the on-chip ROM, and figure 17.81 shows the arrangement of the socket adapter's pins.

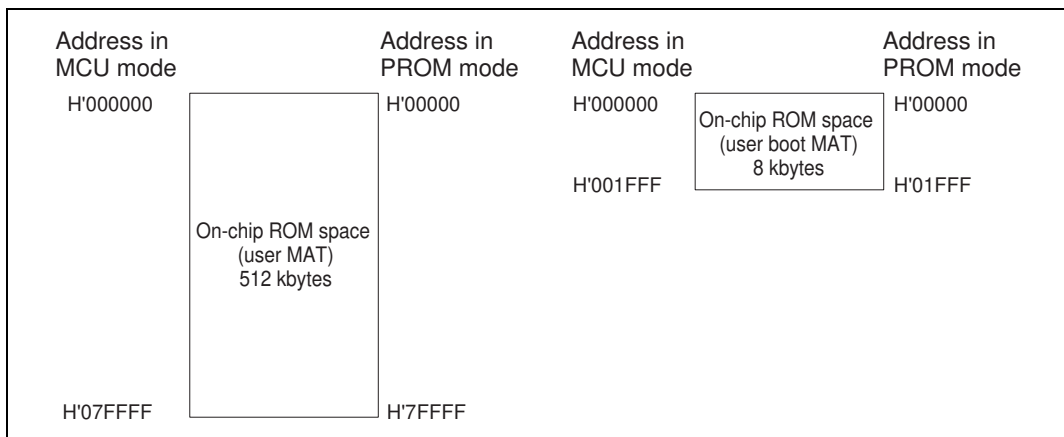

Figure 17.80 Mapping of On-Chip Flash Memory

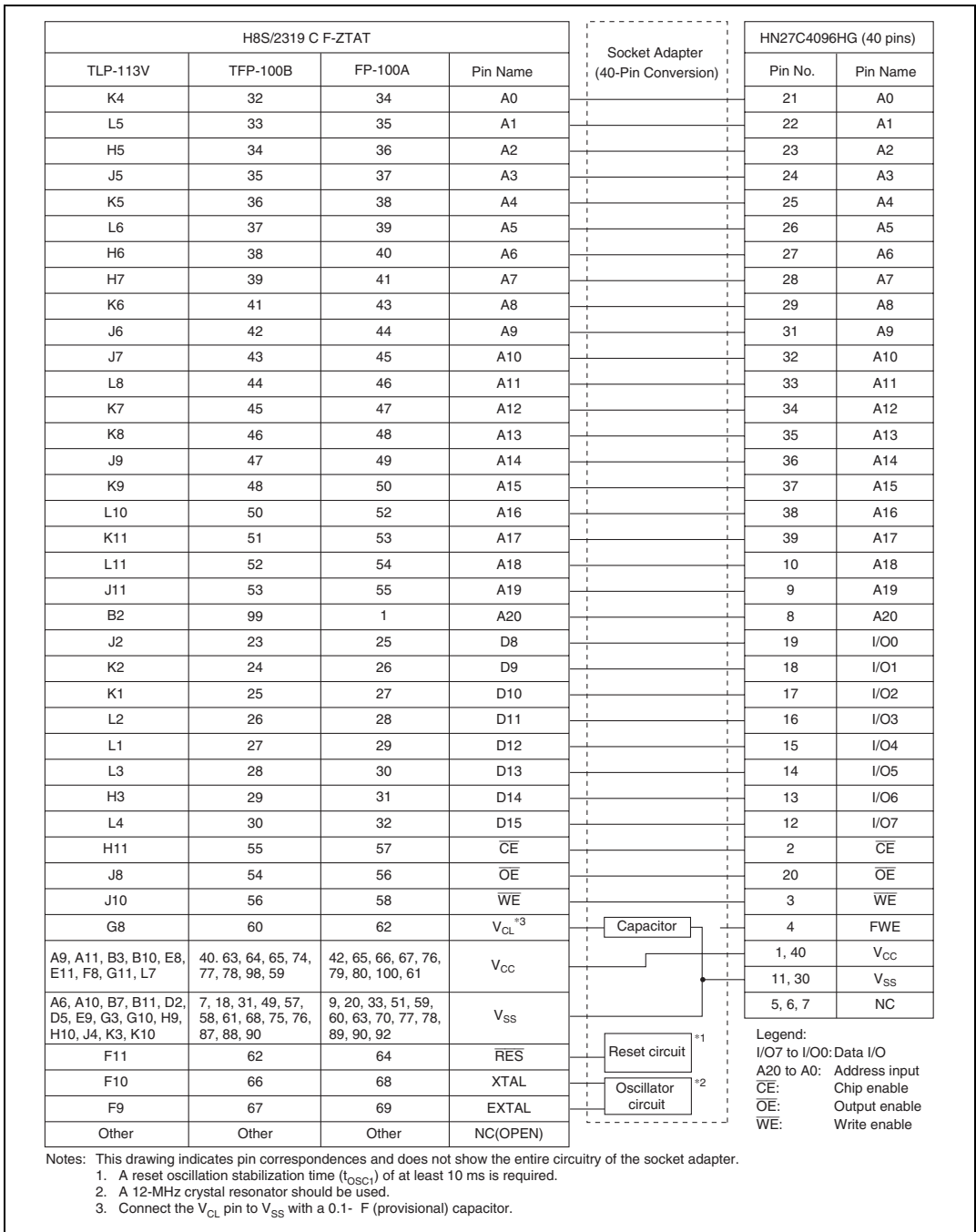

Figure 17.81 Pin Arrangement of the Socket Adapter

17.28.2 PROM Mode Operation

Table 17.57 shows the settings for the operating modes of PROM mode, and table 17.58 lists the commands used in PROM mode. The following sections provide detailed information on each mode.

- Memory-read mode: This mode supports reading, in units of bytes, from the user MAT or user boot MAT.
- Auto-program mode: This mode supports the simultaneous programming of the user MAT and user boot MAT in 128-byte units. Status polling is used to confirm the end of automatic programming.
- Auto-erase mode: This mode only supports the automatic erasing of the entire user MAT or user boot MAT. Status polling is used to confirm the end of automatic erasing.
- Status-read mode: Status polling is used with automatic programming and automatic erasure. Normal completion can be detected by reading the signal on the I/O₆ pin. In status-read mode, error information is output when an error has occurred.

Table 17.57 Settings for Each Operating Mode of PROM Mode

Mode	Pin Name				
	$\overline{\text{CE}}$	$\overline{\text{OE}}$	$\overline{\text{WE}}$	I/O7 to 0	A18 to 0
Read	L	L	H	Data output	Ain
Output disable	L	H	H	Hi-Z	X
Command write	L	H	L	Data input	Ain ^{*2}
Chip disable ^{*1}	H	X	X	Hi-Z	X

Notes: 1. The chip-disable mode is not a standby state; internally, it is an operational state.

2. Ain indicates that there is also an address input in auto-program mode.

Table 17.58 Commands in PROM Mode

Command	Number of Cycles	Memory MAT to be Accessed	1st Cycle			2nd Cycle		
			Mode	Address	Data	Mode	Address	Data
Memory-read mode	1+n	User MAT	Write	X	H'00	Read	RA	Dout
		User boot MAT	Write	X	H'05			
Auto-program mode	129	User MAT	Write	X	H'40	Write	WA	Din
		User boot MAT	Write	X	H'45			
Auto-erase mode	2	User MAT	Write	X	H'20	Write	X	H'20
		User boot MAT	Write	X	H'25			H'25
Status-read mode	2	Common to both MATs	Write	X	H'71	Write	X	H'71

- Notes: 1. In auto-program mode, 129 cycles are required in command writing because of the simultaneous 128-byte write.
2. In memory read mode, the number of cycles varies with the number of address writing cycles (n).

17.28.3 Memory-Read Mode

- (1) On completion of an automatic program, automatic erase, or status read, the LSI enters a command waiting state. So, to read the contents of memory after these operations, issue the command to change the mode to the memory-read mode before reading from the memory.
- (2) In memory-read mode, the writing of commands is possible in the same way as in the command-write state.
- (3) After entering memory-read mode, continuous reading is possible.
- (4) After power has first been supplied, the LSI enters the memory-read mode. For the AC characteristics in memory read mode, see section 17.29.2, AC Characteristics and Timing in PROM Mode.

17.28.4 Auto-Program Mode

- (1) In auto-program mode, programming is in 128-byte units. That is, 128 bytes of data are transferred in succession.
- (2) Even in the programming of less than 128 bytes, 128 bytes of data must be transferred. H'FF should be written to those addresses that are unnecessarily written to.
- (3) Set the low seven bits of the address to be transferred to low level. Inputting an invalid address will result in a programming error, although processing will proceed to the memory-programming operation.
- (4) The memory address is transferred in the 2nd cycle. Do not transfer addresses in the 3rd or later cycles.
- (5) Do not issue commands while programming is in progress.
- (6) When programming, execute automatic programming once for each 128-byte block of addresses. Programming the block at an address where programming has already been performed is not possible.
- (7) To confirm the end of automatic programming, check the signal on the I/O₆ pin. Confirmation in the status-read mode is also possible (status polling of the I/O₇ pin is used to check the end status of automatic programming).
- (8) Status-polling information on the I/O₆ and I/O₇ pins is retained until the next command is written. As long as no command is written, the information is made readable by setting $\overline{\text{CE}}$ and $\overline{\text{OE}}$ for enabling.

For the AC characteristics in auto-program mode, see section 17.29.2, AC Characteristics and Timing in PROM Mode.

17.28.5 Auto-Erase Mode

- (1) Auto-erase mode only supports erasing of the entire memory.
- (2) Do not perform command writing during auto erasing is in progress.
- (3) To confirm the end of automatic erasing, check the signal on the I/O₆ pin. Confirmation in the status-read mode is also possible (status polling of the I/O₇ pin is used to check the end status of automatic erasure).
- (4) Status polling information on the I/O₆ and I/O₇ pins is retained until the next command writing. As long as no command is written, the information is made readable by setting $\overline{\text{CE}}$ and $\overline{\text{OE}}$ for enabling.

For the AC characteristics in auto-erase mode, see section 17.29.2, AC Characteristics and Timing in PROM Mode.

17.28.6 Status-Read Mode

- (1) Status-read mode is used to determine the type of an abnormal termination. Use this mode when automatic programming or automatic erasure ends abnormally.
- (2) The return code is retained until writing of a command that selects a mode other than status-read mode.

Table 17.59 lists the return codes of status-read mode. For the AC characteristics in status-read mode, see section 17.29.2, AC Characteristics and Timing in PROM Mode.

Table 17.59 Return Codes of Status-Read Mode

Pin Name	I/O ₇	I/O ₆	I/O ₅	I/O ₄	I/O ₃	I/O ₂	I/O ₁	I/O ₀
Attribute	Normal end indicator	Command error	Programming error	Erase error	—	—	Programming or erase count exceeded	Invalid address error
Initial value	0	0	0	0	0	0	0	0
Indication	Normal end: 0 Abnormal end: 1	Command error: 1 Otherwise: 0	Programming error: 1 Otherwise: 0	Erase error: 1 Otherwise: 0	—	—	Count exceeded: 1 Otherwise: 0	Invalid address error: 1 Otherwise: 0

Note: I/O₃ and I/O₂ are undefined pins.

17.28.7 Status Polling

- (1) The I/O₇ status-polling output is a flag that indicates the operating status in auto-program or auto-erase mode.
- (2) The I/O₆ status-polling output is a flag that indicates normal/abnormal end of auto-program or auto-erase mode.

Table 17.60 Truth Table of Status-Polling Output

Pin Name	In Progress	Abnormal End	—	Normal End
I/O ₇	0	1	0	1
I/O ₆	0	0	1	1
I/O ₀ to I/O ₅	0	0	0	0

17.28.8 Time Taken in Transition to PROM Mode

Until oscillation has stabilized and while PROM mode is being set up, the LSI is unable to accept commands. After the PROM-mode setup time has elapsed, the LSI enters memory-read mode. See section 17.29.2, AC Characteristics and Timing in PROM Mode.

17.28.9 Notes on Using PROM Mode

- (1) When programming addresses which have previously been programmed, apply auto-erasing before auto-programming.
- (2) When using PROM mode to program a chip that has been programmed/erased in an on-board programming mode, auto-erasing before auto-programming is recommended.
- (3) Do not take the chip out of the PROM programmer or reset the chip during programming or erasure. Flash memory is susceptible to permanent damage since a high voltage is being applied during the programming/erasing. When the reset signal is accidentally input to the chip, the period in the reset state until the reset signal is released should be longer than the normal 100 μ s.
- (4) The flash memory is initially in the erased state when the device is shipped by Renesas Technology. For other chips for which the history of erasure is unknown, auto-erasing as a check and supplement for the initialization (erase) level is recommended.
- (5) This LSI does not support modes such as the product identification mode of general purpose EPROM. Therefore, the device name is not automatically set in the PROM programmer.
- (6) For further information on the writer programmer and its software version, please refer to the instruction manual for the socket adapter.

17.29 Further Information

17.29.1 Serial Communication Interface Specification for Boot Mode

Initiating boot mode enables the boot program to communicate with the host by using the internal SCI. The serial communication interface specification is shown below.

Status

The boot program has three states.

(1) Bit-Rate-Adjustment State

In this state, the boot program adjusts the bit rate to communicate with the host. Initiating boot mode enables starting of the boot program and entry to the bit-rate-adjustment state. The program receives the command from the host to adjust the bit rate. After adjusting the bit rate, the program enters the inquiry/selection state.

(2) Inquiry/Selection State

In this state, the boot program responds to inquiry commands from the host. The device name, clock mode, and bit rate are selected. After selection of these settings, the program is made to enter the programming/erasing state by the command for a transition to the programming/erasing state. The program transfers the libraries required for erasure to the on-chip RAM and erases the user MATs and user boot MATs before the transition.

(3) Programming/erasing state

Programming and erasure by the boot program take place in this state. The boot program is made to transfer the programming/erasing programs to the on-chip RAM by commands from the host. Sum checks and blank checks are executed by sending these commands from the host.

These boot program states are shown in figure 17.82.

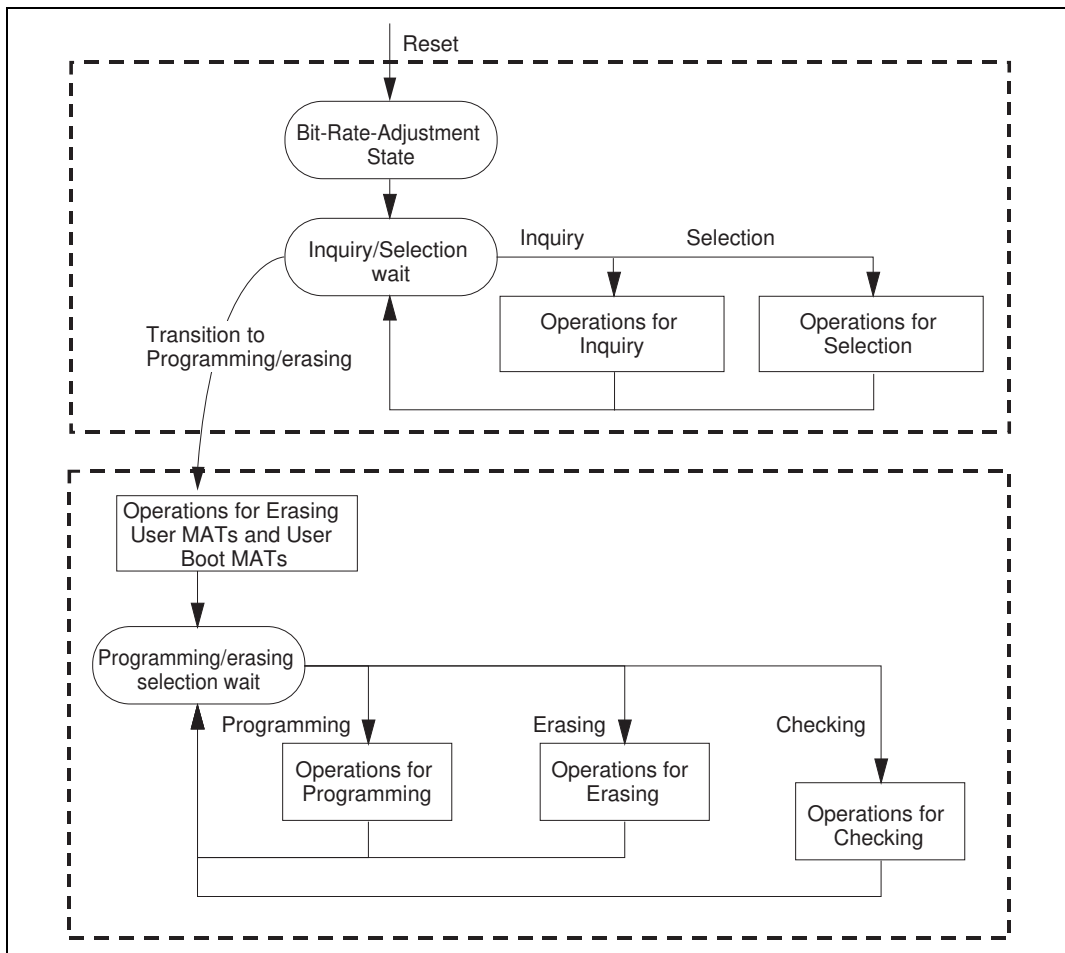

Figure 17.82 Boot Program States

Bit-Rate-Adjustment State

The bit rate is calculated by measuring the period of transfer of a low-level byte (H'00) from the host. The bit rate can be changed by the command for a new bit rate selection. After the bit rate has been adjusted, the boot program enters the inquiry and selection state. The bit-rate-adjustment sequence is shown in figure 17.83.

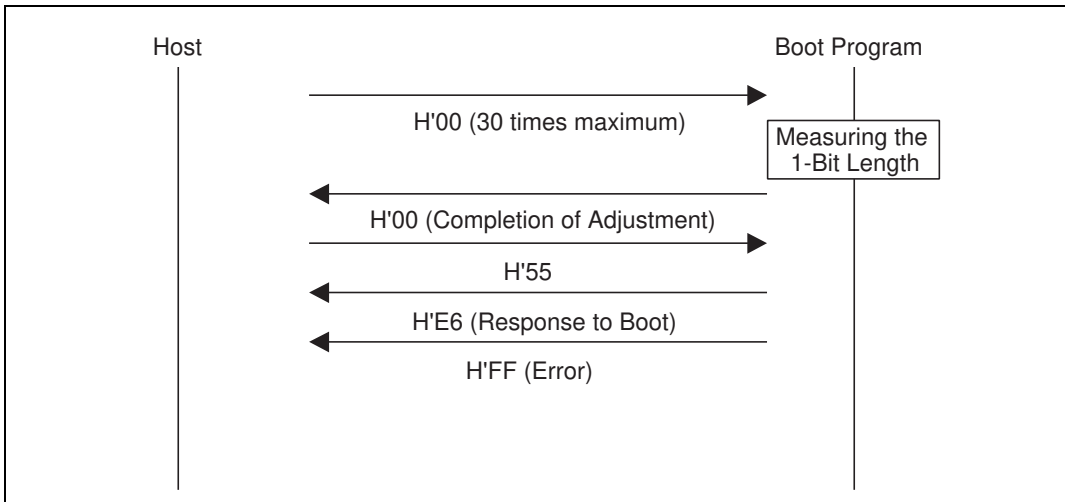

Figure 17.83 Bit-Rate-Adjustment Sequence

Communications Protocol

After adjustment of the bit rate, the protocol for communications between the host and the boot program is as shown below.

(1) One-byte commands and one-byte responses

These commands and responses are comprised of a single byte. These are consists of the inquiries and the ACK for successful completion.

(2) n-byte commands or n-byte responses

These commands and responses are comprised of n bytes of data. These are selections and responses to inquiries.

The amount of programming data is not included under this heading because it is determined in another command.

(3) Error response

The error response is a response to inquiries. It consists of an error response and an error code and comes two bytes.

(4) Programming of n bytes

The size is not specified in commands. The size of n is indicated in response to the programming unit inquiry.

(5) Memory read response

This response consists of four bytes of data.

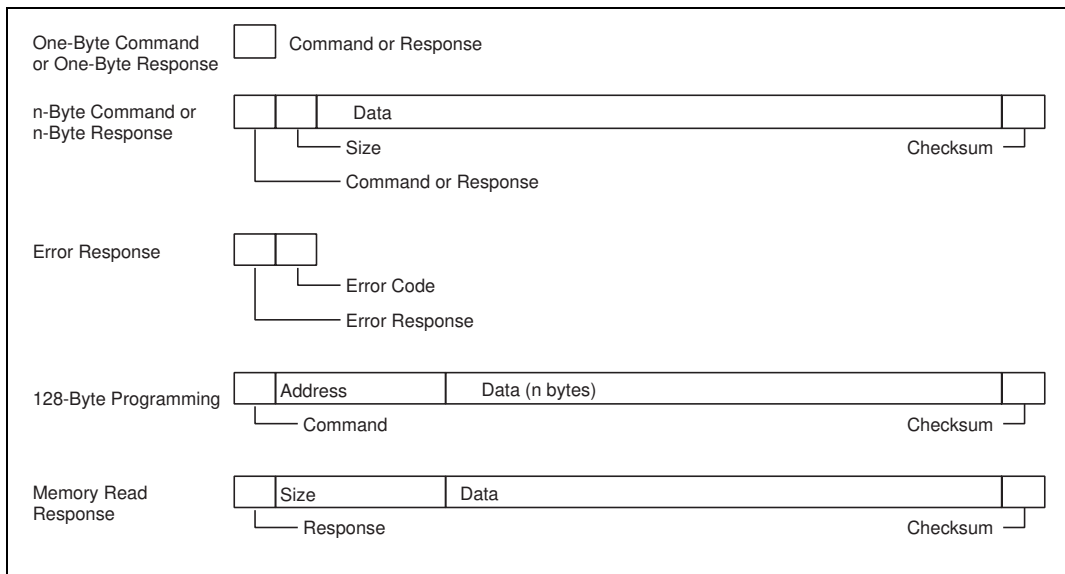

Figure 17.84 Communication Protocol Format

- **Command (1 byte):** Commands including inquiries, selection, programming, erasing, and checking
- **Response (1 byte):** Response to an inquiry
- **Size (1 byte):** The amount of data for transmission excluding the command, amount of data, and checksum
- **Checksum (1 byte):** The checksum is calculated so that the total of all values from the command byte to the SUM byte becomes H'00
- **Data (n bytes):** Detailed data of a command or response
- **Error Response (1 byte):** Error response to a command
- **Error Code (1 byte):** Type of the error
- **Address (4 bytes):** Address for programming
- **Data (n bytes):** Data to be programmed (the size is indicated in the response to the programming unit inquiry.)
- **Size (4 bytes):** Four-byte response to a memory read

Inquiry and Selection States

The boot program returns information from the flash memory in response to the host's inquiry commands and sets the device code, clock mode, and bit rate in response to the host's selection command.

Inquiry and selection commands are listed below.

Table 17.61 Inquiry and Selection Commands

Command	Command Name	Description
H'20	Supported Device Inquiry	Inquiry regarding device codes and product names of F-ZTAT
H'10	Device Selection	Selection of device code
H'21	Clock Mode Inquiry	Inquiry regarding numbers of clock modes and values of each mode
H'11	Clock Mode Selection	Indication of the selected clock mode
H'22	Multiplication Ratio Inquiry	Inquiry regarding the number of frequency-multiplied clock types, the number of multiplication ratios, and the values of each multiple
H'23	Operating Clock Frequency Inquiry	Inquiry regarding the maximum and minimum values of the main clock and peripheral clocks
H'24	User Boot MAT Information Inquiry	Inquiry regarding the number of user boot MATs and the start and last addresses of each MAT
H'25	User MAT Information Inquiry	Inquiry regarding the a number of user MATs and the start and last addresses of each MAT
H'26	Block for Erasing Information Inquiry	Inquiry regarding the number of blocks and the start and last addresses of each block
H'27	Programming Unit Inquiry	Inquiry regarding the unit of programming data
H'3F	New Bit Rate Selection	Selection of new bit rate
H'40	Transition to Programming/erasing State	Erasing of user MAT and user boot MAT, and entry to programming/erasing state
H'4F	Boot Program Status Inquiry	Inquiry into the operated status of the boot program

The selection commands, which are device selection (H'10), clock mode selection (H'11), and new bit rate selection (H'3F), should be sent from the host in that order. These commands will certainly be needed. When two or more selection commands are sent at once, the last command will be valid.

All of these commands, except for the boot program status inquiry command (H'4F), will be valid until the boot program receives the programming/erasing transition (H'40). The host can choose the needed commands out of the commands and inquiries listed above. The boot program status inquiry command (H'4F) is valid after the boot program has received the programming/erasing transition command (H'40).

(1) Supported device inquiry

The boot program will return the device codes of supported devices and the product code of the F-ZTAT in response to the supported device inquiry.

Command

H'20

- Command, H'20, (1 byte): Inquiry regarding supported devices

Response	H'30	Size	A number of devices	
	A number of characters	Device code		Product name
	...			
	SUM			

- Response, H'30, (1 byte): Response to the supported device inquiry
- Size (1 byte): Number of bytes to be transmitted, excluding the command, amount of data, and checksum, that is, the amount of data contributes by the product names, the number of devices, characters, and device codes
- A number of devices (1 byte): The number of device types supported by the boot program
- A number of characters (1 byte): The number of characters in the device codes and boot program's name
- Device code (4 bytes): Code of the supporting product
- Product name (n bytes): Type name of the boot program in ASCII-coded characters
- SUM (1 byte): Checksum

The checksum is calculated so that the total number of all values from the command byte to the SUM byte becomes H'00.

(2) Device Selection

The boot program will set the supported device to the specified device code. The program will return the selected device code in response to the inquiry after this setting has been made.

Command

H'10	Size	Device code	SUM
------	------	-------------	-----

- Command, H'10, (1 byte): Device selection
- Size (1 byte): Amount of device-code data
This is fixed to 4

- Device code (4 bytes): Device code returned in response to the supported device inquiry (ASCII-code)
- SUM (1 byte): Checksum

Response

H'06

- Response, H'06, (1 byte): Response to the device selection command
ACK will be returned when the device code matches.

Error response

H'90	ERROR
------	-------

- Error response, H'90, (1 byte): Error response to the device selection command
- Error: (1 byte): Error code
H'11: Sum check error
H'21: Device code error, that is, the device code does not match

(3) Clock Mode Inquiry

The boot program will return the supported clock modes in response to the clock mode inquiry.

Command

H'21

- Command, H'21, (1 byte): Inquiry regarding clock mode

Response

H'31	Size	Mode	SUM
------	------	------	-----

- Response, H'31, (1 byte): Response to the clock-mode inquiry
- Size (1 byte): Amount of data that represents the modes
- Mode (1 byte): Values of the supported clock modes (i.e. H'01 means clock mode 1.)
- SUM (1 byte): Checksum

(4) Clock Mode Selection

The boot program will set the specified clock mode. The program will return the selected clock-mode information after this setting has been made.

The clock-mode selection command should be sent after the device-selection commands.

Command

H'11	Size	Mode	SUM
------	------	------	-----

- Command, H'11, (1 byte): Selection of clock mode
- Size (1 byte): Amount of data that represents the modes
- Mode (1 byte): A clock mode returned in reply to the supported clock mode inquiry.
- SUM (1 byte): Checksum

Response

H'06

- Response, H'06, (1 byte): Response to the clock mode selection command
ACK will be returned when the clock mode matches.

Error Response

H'91	ERROR
------	-------

- Error response, H'91, (1 byte): Error response to the clock mode selection command
- ERROR, (1 byte) : Error code
H'11: Checksum error
H'22: Clock mode error, that is, the clock mode does not match.

Even when the clock mode value is H'00 or H'01 for clock mode inquiry, clock mode selection is performed for each value.

(5) Multiplication Ratio-Inquiry

The boot program will return the supported multiplication and division ratios.

Command

H'22

- Command, H'22, (1 byte): Inquiry regarding multiplication ratio

Response	H'32	Size	The Number of Clock					
	The number of multiplication ratios	Multiplication ratio	...					
	...							
	SUM							

- Response, H'32, (1 byte): Response to the multiplication ratio inquiry
- Size (1 byte): The amount of data that represents the clock sources, the number of multiplication ratios, and the multiplication ratios
- A number of types (1 byte): The number of supported multiplied clock types (e.g. when there are two multiplied clock types, which are the main and peripheral clocks, the number of types will be H'02.)
- A number of multiplication ratios (1 byte): The number of multiplication ratios for each type (e.g. the number of multiplication ratios to which the main clock can be set and the peripheral clock can be set.)
- Multiplication ratio (1 byte)
 - Multiplication ratio: The value of the multiplication ratio (e.g. when the clock-frequency multiplier is four, the value of multiplication ratio will be H'04.)

— Division ratio: The inverse of the division ratio, i.e. a negative number (e.g. when the clock is divided by two, the value of division ratio will be H'FE. $H'FE = D'-2$)

The number of multiplication ratios returned is the same as the number of multiplication ratios and as many groups of data are returned as there are types.

- SUM (1 byte): Checksum

(6) Operating Clock Frequency Inquiry

The boot program will return the number of operating clock frequencies, and the maximum and minimum values.

Command

H'23

- Command, H'23, (1 byte): Inquiry regarding operating clock frequencies

Response	H'33	Size	A number of operating clock frequencies
	The minimum value of operating clock frequency		The maximum value of operating clock frequency
	...		
	SUM		

- Response, H'33, (1 byte): Response to operating clock frequency inquiry
- Size (1 byte): The number of bytes that represents the minimum values, maximum values, and the number of types.
- A number of types (1 byte): The number of supported operating clock frequency types (e.g. when there are two operating clock frequency types, which are the main and peripheral clocks, the number of types will be H'02.)
- Minimum value of operating clock frequency (2 bytes): The minimum value of the multiplied or divided clock frequency.
The minimum and maximum values represent the values in MHz, valid to the hundredths place of MHz, and multiplied by 100. (e.g. when the value is 20.00 MHz, it will be D'2000 and H'07D0.)
- Maximum value (2 bytes) : Maximum value among the multiplied or divided clock frequencies.
There are as many pairs of minimum and maximum values as there are operating clock frequencies.
- SUM (1 byte): Checksum

(7) User Boot MAT Information Inquiry

The boot program will return the number of user boot MATs and their addresses.

Command

H'24

- Command, H'24, (1 byte): Inquiry regarding user boot MAT information

Response	H'34	Size	A Number of Areas	
	Area-Start Address		Area-Last Address	
	...			
	SUM			

- Response, H'34, (1 byte): Response to user boot MAT information inquiry
- Size (1 byte): The number of bytes that represents the number of areas, area-start addresses, and area-last address
- A Number of Areas (1 byte): The number of non-consecutive user boot MAT areas
When user boot MAT areas are consecutive, the number of areas returned is H'01.
- Area-Start Address (1 byte): Start address of the area
- Area-Last Address (1 byte): Last address of the area
There are as many groups of data representing the start and last addresses as there are areas.
- SUM (1 byte): Checksum

(8) User MAT Information Inquiry

The boot program will return the number of user MATs and their addresses.

Command

H'25

- Command, H'25, (1 byte): Inquiry regarding user MAT information

Response	H'35	Size	A Number of Areas	
	Area-Start Address		Area-Last Address	
	...			
	SUM			

- Response, H'35, (1 byte): Response to the user MAT information inquiry
- Size (1 byte): The number of bytes that represents the number of areas, area-start address and area-last address
- A Number of Areas (1 byte): The number of non-consecutive user MAT areas
When the user MAT areas are consecutive, the number of areas is H'01.
- Area-Start Address (4 bytes): Start address of the area

- Area-Last Address (4 bytes): Last address of the area
There are as many groups of data representing the start and last addresses as there are areas.
- SUM (1 byte): Checksum

(9) Erased Block Information Inquiry

The boot program will return the number of erased blocks and their addresses.

Command

H'26

- Command, H'26, (1 byte): Inquiry regarding erased block information

Response	H'36	Size	A number of blocks	
	Block Start Address			Block Last Address
	...			
	SUM			

- Response, H'36, (1 byte): Response to the number of erased blocks and addresses
- Size (1 byte): The number of bytes that represents the number of blocks, block-start addresses, and block-last addresses.
- A number of blocks (1 byte): Number of erased blocks in flash memory
- Block Start Address (4 bytes) : Start address of a block
- Block Last Address (4 bytes) : Last address of a block
There are as many groups of data representing the start and last addresses as there are blocks.
- SUM: Checksum

(10) Programming Unit Inquiry

The boot program will return the programming unit used to program data.

Command

H'27

- Command, H'27, (1 byte): Inquiry regarding programming unit

Response	H'37	Size	Programming unit	SUM

- Response, H'37, (1 byte): Response to programming unit inquiry
- Size (1 byte): The number of bytes that indicate the programming unit, which is fixed to 2
- Programming unit (2 bytes): A unit for programming
This is the unit for reception of programming.
- SUM (1 byte): Checksum

(11) New Bit-Rate Selection

The boot program will set a new bit rate and return the new bit rate.

This selection should be sent after sending the clock mode selection command.

Command	H'3F	Size	Bit rate	Input frequency
	Number of multiplication ratios	Multiplication ratio 1	Multiplication ratio 2	
	SUM			

- Command, H'3F, (1 byte): Selection of new bit rate
- Size (1 byte): The number of bytes that represents the bit rate, input frequency, number of multiplication ratios, and multiplication ratio
- Bit rate (2 bytes): New bit rate
One hundredth of the value (e.g. when the value is 19200 bps, the bit rate is H'00C0, which is D'192.)
- Input frequency (2 bytes): Frequency of the clock input to the boot program
This is valid to the hundredths place and represents the value in MHz multiplied by 100. (e.g. when the value is 20.00 MHz, the input frequency is H'07D0 (= D'2000).)
- Number of multiplication ratios (1 byte): The number of multiplication ratios to which the device can be set. Normally the value is two: main operating frequency and peripheral module operating frequency.
- Multiplication ratio 1 (1 byte): The value of multiplication or division ratios for the main operating frequency
 - Multiplication ratio (1 byte): The value of the multiplication ratio (e.g. when the clock frequency is multiplied by four, the multiplication ratio will be H'04. With this LSI it should be set to H'01.)
 - Division ratio: The inverse of the division ratio, as a negative number (e.g. when the clock frequency is divided by two, the value of division ratio will be H'FE. H'FE = D'-2. With this LSI it should be set to H'01.)
- Multiplication ratio 2 (1 byte): The value of multiplication or division ratios for the peripheral frequency
 - Multiplication ratio (1 byte): The value of the multiplication ratio (e.g. when the clock frequency is multiplied by four, the multiplication ratio will be H'04. With this LSI it should be set to H'01.)
 - Division ratio: The inverse of the division ratio, as a negative number (e.g. when the clock is divided by two, the value of division ratio will be H'FE. H'FE = D'-2. With this LSI it should be set to H'01.)
- SUM (1 byte): Checksum

Response

H'06

- Response, H'06, (1 byte): Response to selection of a new bit rate
When it is possible to set the bit rate, the response will be ACK.

Error Response

H'BF	ERROR
------	-------

- Error response, H'BF, (1 byte): Error response to selection of new bit rate
- ERROR: (1 byte): Error code
 - H'11: Sum checking error
 - H'24: Bit-rate selection error
The rate is not available.
 - H'25: Error in input frequency
This input frequency is not within the specified range.
 - H'26: Multiplication-ratio error*
The ratio does not match an available ratio.
 - H'27: Operating frequency error*
The frequency is not within the specified range.

Note: * This error does not occur with this LSI.

Received Data Check

The methods for checking of received data are listed below.

(1) Input frequency

The received value of the input frequency is checked to ensure that it is within the range of minimum to maximum frequencies which matches the clock modes of the specified device. When the value is out of this range, an input-frequency error is generated.

(2) Multiplication ratio

The received value of the multiplication ratio or division ratio is checked to ensure that it matches the clock modes of the specified device. When the value is out of this range, an input-frequency error is generated.

(3) Operating frequency error

Operating frequency is calculated from the received value of the input frequency and the multiplication or division ratio. The input frequency is input to the LSI and the LSI is operated at the operating frequency. The expression is given below.

Operating frequency = Input frequency × Multiplication ratio , or

Operating frequency = Input frequency ÷ Division ratio

The calculated operating frequency should be checked to ensure that it is within the range of minimum to maximum frequencies which are available with the clock modes of the specified device. When it is out of this range, an operating frequency error is generated.

(4) Bit rate

Peripheral operating clock (ϕ), bit rate (B), clock select (CKS) in the serial mode register (SMR). The error as calculated by the method below is checked to ensure that it is less than 4%. When it is 4% or more, a bit-rate selection error is generated.

$$\text{Error (\%)} = \left\{ \left[\frac{\phi * 10^6}{(N+1) * B * 64 * 2^{(2*n-1)}} \right] - 1 \right\} * 100$$

When the new bit rate is selectable, the rate will be set in the register after sending ACK in response. The host will send an ACK with the new bit rate for confirmation and the boot program will response with that rate.

Confirmation H'06

- Confirmation, H'06, (1 byte): Confirmation of a new bit rate

Response H'06

- Response, H'06, (1 byte): Response to confirmation of a new bit rate

The sequence of new bit-rate selection is shown in figure 17.85.

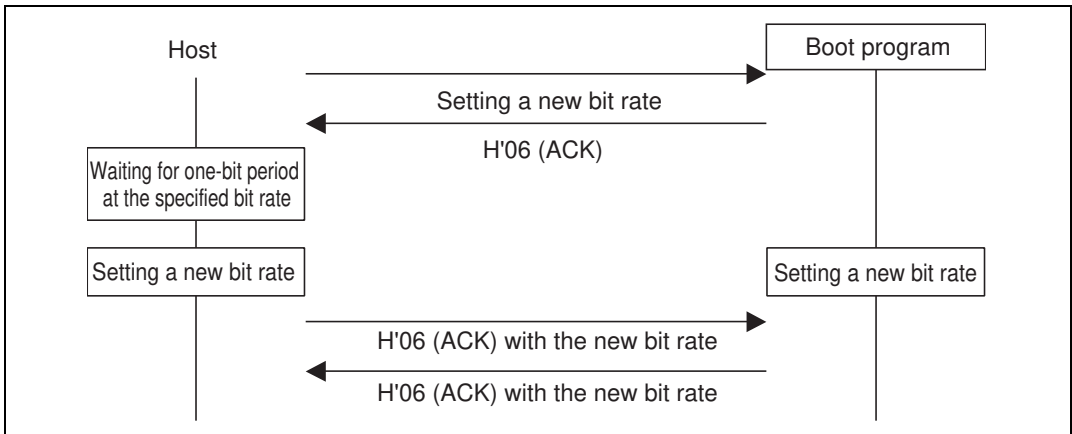

Figure 17.85 New Bit-Rate Selection Sequence

Transition to Programming/Erasing State

The boot program will transfer the erasing program, and erase the user MATs and user boot MATs in that order. On completion of this erasure, ACK will be returned and will enter the programming/erasing state.

The host should select the device code, clock mode, and new bit rate with device selection, clock-mode selection, and new bit-rate selection commands, and then send the command for the transition to programming/erasing state. These procedure should be carried out before sending of the programming selection command or program data.

Command

H'40

- Command, H'40, (1 byte): Transition to programming/erasing state

Response

H'06

- Response, H'06, (1 byte): Response to transition to programming/erasing state
The boot program will send ACK when the user MAT and user boot MAT have been erased by the transferred erasing program.

Error Response

H'C0	H'51
------	------

- Error response, H'C0, (1 byte): Error response for user boot MAT blank check
- Error code, H'51, (1 byte): Erasing error
An error occurred and erasure was not completed.

Command Error

A command error will occur when a command is undefined, the order of commands is incorrect, or a command is unacceptable. Issuing a clock-mode selection command before a device selection or an inquiry command after the transition to programming/erasing state command, are examples.

Error	H'80	H'xx
Response		

- Error response, H'80, (1 byte): Command error
- Command, H'xx, (1 byte): Received command

Command Order

The order for commands in the inquiry selection state is shown below.

- (1) A supported device inquiry (H'20) should be made to inquire about the supported devices.
- (2) The device should be selected from among those described by the returned information and set with a device-selection (H'10) command.
- (3) A clock-mode inquiry (H'21) should be made to inquire about the supported clock modes.
- (4) The clock mode should be selected from among those described by the returned information and set.
- (5) After selection of the device and clock mode, inquiries for other required information should be made, such as the multiplication-ratio inquiry (H'22) or operating frequency inquiry (H'23).
- (6) A new bit rate should be selected with the new bit-rate selection (H'3F) command, according to the returned information on multiplication ratios and operating frequencies.
- (7) After selection of the device and clock mode, the information of the user boot MAT and user MAT should be made to inquire about the user boot MAT's information inquiry (H'24), user MAT's information inquiry (H'25), erased block information inquiry (H'26), programming unit inquiry (H'27).
- (8) After making inquiries and selecting a new bit rate, issue the transition to programming/erasing state (H'40) command. The boot program will then enter the programming/erasing state.

Programming/Erasing State

A programming selection command makes the boot program select the programming method, an n-byte programming command makes it program the memory with data, and an erasing selection command and block erasing command make it erase the block. The programming/erasing commands are listed below.

Table 17.62 Programming/Erasing Command

Command	Command Name	Description
H'42	User boot MAT programming selection	Transfers the user boot MAT programming program
H'43	User MAT programming selection	Transfers the user MAT programming program
H'50	128-byte programming	Programs 128 bytes of data
H'48	Erasing selection	Transfers the erasing program
H'58	Block erasing	Erases a block of data
H'52	Memory read	Reads the contents of memory
H'4A	User boot MAT sum check	Checks the checksum of the user boot MAT
H'4B	User MAT sum check	Checks the checksum of the user MAT
H'4C	User boot MAT blank check	Checks whether the contents of the user boot MAT are blank
H'4D	User MAT blank check	Checks whether the contents of the user MAT are blank
H'4F	Boot program status inquiry	Inquires into the boot program's status

(1) Programming

Programming is executed by a programming-selection command and an 128-byte programming command.

Firstly, the host should send the programming-selection command and select the programming method and programming MATs. There are two programming selection commands, and selection is according to the area and method for programming.

- User boot MAT programming selection
- User MAT programming selection

After issuing the programming selection command, the host should send the 128-byte programming command. The 128-byte programming command that follows the selection command represents the data programmed according to the method specified by the selection command. When more than 128-byte data is programmed, 128-byte commands should repeatedly be executed. Sending an 128-byte programming command with H'FFFFFFFF as the address will stop the programming. On completion of programming, the boot program will wait for selection of programming or erasing.

Where the sequence of programming operations that is executed includes programming with another method or of another MAT, the procedure must be repeated from the programming selection command.

The sequence for programming-selection and 128-byte programming commands is shown in figure 17.86.

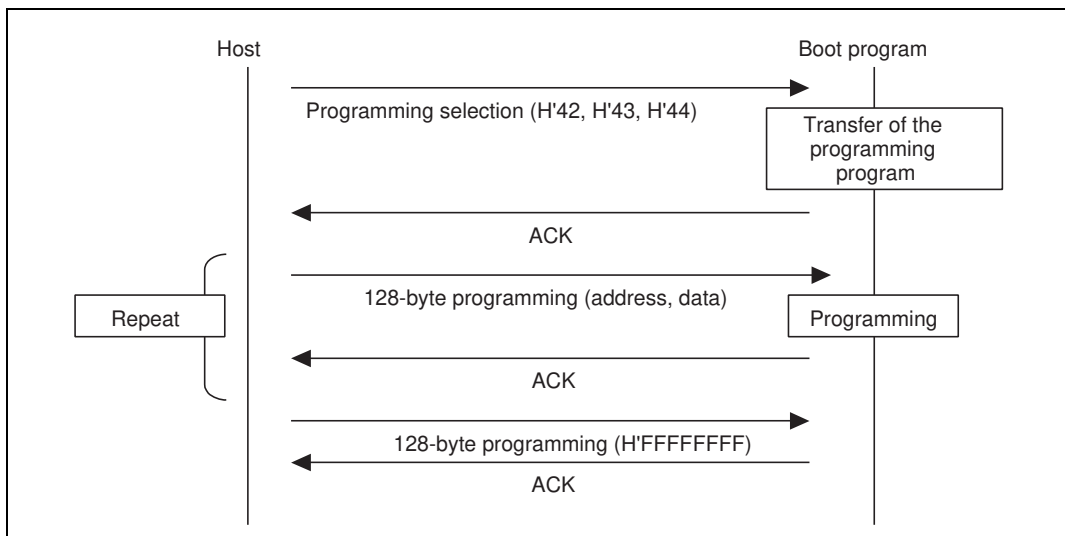

Figure 17.86 Programming Sequence

(2) User Boot MAT Programming Selection

The boot program will transfer a programming program. The data is programmed to the user boot MATs by the transferred programming program.

Command

H'42

- Command, H'42, (1 byte): User boot-program programming selection

Response

H'06

- Response, H'06, (1 byte): Response to user boot-program programming selection
When the programming program has been transferred, the boot program will return ACK.

Error Response

H'C2	ERROR
------	-------

- Error response: H'C2 (1 byte): Error response to user boot MAT programming selection
- ERROR: (1 byte): Error code
H'54: Selection processing error (transfer error occurs and processing is not completed)

(3) User MAT Programming Selection.

The boot program will transfer a programming program. The data is programmed to the user MATs by the transferred programming program.

Command

H'43

- Command, H'43, (1 byte): User-program programming selection

Response

H'06

- Response, H'06, (1 byte): Response to user-program programming selection
When the programming program has been transferred, the boot program will return ACK.

Error Response

H'C3	ERROR
------	-------

- Error response: H'C3 (1 byte): Error response to user MAT programming selection
- ERROR: (1 byte): Error code
H'54: Selection processing error (transfer error occurs and processing is not completed)

(4) 128-Byte Programming

The boot program will use the programming program transferred by the programming selection to program the user boot MATs or user MATs.

Command	H'50	Address						
	Data	...						
	...							
	SUM							

- Command, H'50, (1 byte): 128-byte programming
- Programming Address (4 bytes): Start address for programming
Multiple of the size specified in response to the programming unit inquiry
(i.e. H'00, H'01, H'00, H'00: H'01000000)
- Programming Data (128 bytes): Data to be programmed
The size is specified in the response to the programming unit inquiry.
- SUM (1 byte): Checksum

Response

H'06

- Response, H'06, (1 byte): Response to 128-byte programming
On completion of programming, the boot program will return ACK.

Error Response	H'D0	ERROR
----------------	------	-------

- Error response, H'D0, (1 byte): Error response for 128-byte programming
- ERROR: (1 byte): Error code
 - H'11: Checksum error
 - H'2A: Address error
 - The address is not within the specified range.
 - H'53: Programming error
 - A programming error has occurred and programming cannot be continued.

The specified address should match the unit for programming of data. For example, when the programming is in 128-byte units, the lower byte of the address should be H'00 or H'80. When there are less than 128 bytes of data to be programmed, the host should fill the rest with H'FF.

Sending the 128-byte programming command with the address of H'FFFFFFFF will stop the programming operation. The boot program will interpret this as the end of the programming and wait for selection of programming or erasing.

Command	H'50	Address	SUM
---------	------	---------	-----

- Command, H'50, (1 byte): 128-byte programming
- Programming Address (4 bytes): End code is H'FF, H'FF, H'FF, H'FF.
- SUM (1 byte): Checksum

Response	H'06
----------	------

- Response: H'06 (1 byte): Response to 128-byte programming
 - On completion of programming, the boot program will return ACK.

Error Response	H'D0	ERROR
----------------	------	-------

- Error Response, H'D0, (1 byte): Error response for 128-byte programming
- ERROR: (1 byte): Error code
 - H'11: Checksum error
 - H'53: Programming error
 - An error has occurred in programming and programming cannot be continued.

Erase

Erase is performed with the erase selection and block erase command.

Firstly, erase is selected by the erase selection command and the boot program then erases the specified block. The command should be repeatedly executed if two or more blocks are to be erased. Sending a block-erase command from the host with the block number H'FF will stop the erasure operating. On completion of erasing, the boot program will wait for selection of programming or erasing.

The sequences of the issuing of erase selection commands and the erasure of data are shown in figure 17.87.

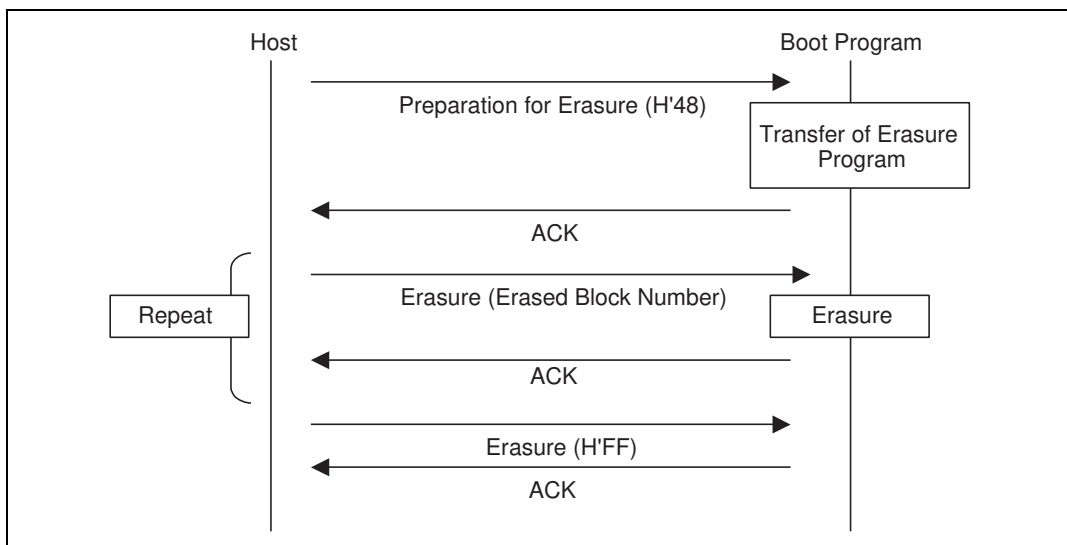

Figure 17.87 Erasure Sequence

(1) Erasure Selection

The boot program will transfer the erasure program. User MAT data is erased by the transferred erasure program.

Command H'48

- Command, H'48, (1 byte): Erasure selection

Response H'06

- Response, H'06, (1 byte): Response for erasure selection

After the erasure program has been transferred, the boot program will return ACK.

Error Response	H'C8	ERROR
----------------	------	-------

- Error response: H'C8 (1 byte): Error response to erasing selection
- ERROR: (1 byte): Error code
 - H'54: Selection processing error (transfer error occurs and processing is not completed)

(2) Block Erasure

The boot program will erase the contents of the specified block.

Command	H'58	Size	Block Number	SUM
---------	------	------	--------------	-----

- Command, H'58, (1 byte): Erasure
- Size (1 byte): The number of bytes that represents the erasure block number
This is fixed to 1.
- Block Number (1 byte): Number of the block to be erased
- SUM (1 byte): Checksum

Response	H'06
----------	------

- Response, H'06, (1 byte): Response to Erasure
After erasure has been completed, the boot program will return ACK.

Error Response	H'D8	ERROR
----------------	------	-------

- Error Response, H'D8, (1 byte): Error code
- ERROR: (1 byte): Error code
 - H'11: Sum check error
 - H'29: Block number error
Block number is incorrect.
 - H'51: Erasure error
An error has occurred during erasure.

On receiving block number H'FF, the boot program will stop erasure and wait for a selection command.

Command	H'58	Size	Block Number	SUM
---------	------	------	--------------	-----

- Command, H'58, (1 byte): Erasure
- Size, (1 byte): The number of bytes that represents the block number
This is fixed to 1.

- Block Number (1 byte): H'FF
Stop code for erasure
- SUM (1 byte): Checksum

Response

H'06

- Response, H'06, (1 byte): Response to end of erasure (ACK)
When erasure is to be performed after the block number H'FF has been sent, the procedure should be executed from the erasure selection command.

Memory Read

The boot program will return the data in the specified address.

Command	H'52	Size	Area	Read address
	Read size			SUM

- Command: H'52 (1 byte): Memory read
- Size (1 byte): Amount of data that represents the area, read address, and read size (fixed at 9)
- Area (1 byte)
 - H'00: User boot MAT
 - H'01: User MAT

An address error occurs when the area setting is incorrect.
- Read address (4 bytes): Start address to be read from
- Read size (4 bytes): Size of data to be read
- SUM (1 byte): Checksum

Response	H'52	Read size							
	Data	...							
	SUM								

- Response: H'52 (1 byte): Response to memory read
- Read size (4 bytes): Size of data to be read
- Data (n bytes): Data for the read size from the read address
- SUM (1 byte): Checksum

Error Response

H'D2	ERROR
------	-------

- Error response: H'D2 (1 byte): Error response to memory read
- ERROR: (1 byte): Error code
 - H'11: Sum check error

H'2A: Address error

The read address is not in the MAT.

H'2B: Size error

The read size exceeds the MAT.

User-Boot Program Sum Check

The boot program will return the byte-by-byte total of the contents of the bytes of the user-boot program.

Command

H'4A

- Command, H'4A, (1 byte): Sum check for user-boot program

Response

H'5A	Size	Checksum of user boot program	SUM
------	------	-------------------------------	-----

- Response, H'5A, (1 byte): Response to the sum check of user-boot program
- Size (1 byte): The number of bytes that represents the checksum
This is fixed to 4.
- Checksum of user boot program (4 bytes): Checksum of user boot MATs
The total of the data is obtained in byte units.
- SUM (1 byte): Sum check for data being transmitted

User-Program Sum Check

The boot program will return the byte-by-byte total of the contents of the bytes of the user program.

Command

H'4B

- Command, H'4B, (1 byte): Sum check for user program

Response

H'5B	Size	Checksum of user program	SUM
------	------	--------------------------	-----

- Response, H'5B, (1 byte): Response to the sum check of the user program
- Size (1 byte): The number of bytes that represents the checksum
This is fixed to 4.
- Checksum of user boot program (4 bytes): Checksum of user MATs
The total of the data is obtained in byte units.
- SUM (1 byte): Sum check for data being transmitted

User Boot MAT Blank Check

The boot program will check whether or not all user boot MATs are blank and return the result.

Command

H'4C

- Command, H'4C, (1 byte): Blank check for user boot MAT

Response

H'06

- Response, H'06, (1 byte): Response to the blank check of user boot MAT
If all user MATs are blank (H'FF), the boot program will return ACK.

Error Response

H'CC	H'52
------	------

- Error Response, H'CC, (1 byte): Response to blank check for user boot MAT
- Error Code, H'52, (1 byte): Erasure has not been completed.

User MAT Blank Check

The boot program will check whether or not all user MATs are blank and return the result.

Command

H'4D

- Command, H'4D, (1 byte): Blank check for user MATs

Response

H'06

- Response, H'06, (1 byte): Response to the blank check for user boot MATs
If the contents of all user MATs are blank (H'FF), the boot program will return ACK.

Error Response

H'CD	H'52
------	------

- Error Response, H'CD, (1 byte) : Error response to the blank check of user MATs.
- Error code H'52 (1 byte): Erasure has not been completed.

Boot Program State Inquiry

The boot program will return indications of its present state and error condition. This inquiry can be made in the inquiry/selection state or the programming/erasing state.

Command

H'4F

- Command, H'4F, (1 byte): Inquiry regarding boot program's state

Response

H'5F	Size	STATUS	ERROR	SUM
------	------	--------	-------	-----

- Response, H'5F, (1 byte): Response to boot program state inquiry
- Size (1 byte): The number of bytes that represents the STATUS and ERROR. This is fixed to 2.
- STATUS (1 byte): State of the boot program
For details, see table 17.63.
- ERROR (1 byte): Error state
ERROR = 0 indicates normal operation.
ERROR = 1 indicates error has occurred
For details, see table 17.64.
- SUM (1 byte): Checksum

Table 17.63 Status Code

Code	Description
H'11	Device Selection Wait
H'12	Clock Mode Selection Wait
H'13	Bit Rate Selection Wait
H'1F	Programming/Erasing State Transition Wait (Bit rate selection is completed)
H'31	Programming State for Erasure
H'3F	Programming/Erasing Selection Wait (Erasure is completed)
H'4F	Programming Data Receive Wait (Programming is completed)
H'5F	Erasure Block Specification Wait (Erasure is completed)

Table 17.64 Error Code

Code	Description
H'00	No Error
H'11	Sum Check Error
H'12	Program Size Error
H'21	Device Code Mismatch Error
H'22	Clock Mode Mismatch Error
H'24	Bit Rate Selection Error
H'25	Input Frequency Error
H'26	Multiplication Ratio Error
H'27	Operating Frequency Error
H'29	Block Number Error
H'2A	Address Error
H'2B	Data Length Error
H'51	Erasure Error
H'52	Erasure Incompletion Error
H'53	Programming Error
H'54	Selection Error
H'80	Command Error
H'FF	Bit-Rate-Adjustment Confirmation Error

17.29.2 AC Characteristics and Timing in PROM Mode

Table 17.65 AC Characteristics in Memory Read Mode

Condition: $V_{CC} = 3.3 \text{ V} \pm 0.3 \text{ V}$, $V_{SS} = 0 \text{ V}$, $T_a = 25^\circ\text{C} \pm 5^\circ\text{C}$

Code	Symbol	Min	Max	Unit
Command write cycle	t_{nxtc}	20	—	μs
$\overline{\text{CE}}$ hold time	t_{ceh}	0	—	ns
$\overline{\text{CE}}$ setup time	t_{ces}	0	—	ns
Data hold time	t_{dh}	50	—	ns
Data setup time	t_{ds}	50	—	ns
Programming pulse width	t_{wep}	70	—	ns
$\overline{\text{WE}}$ rise time	t_r	—	30	ns
$\overline{\text{WE}}$ fall time	t_f	—	30	ns

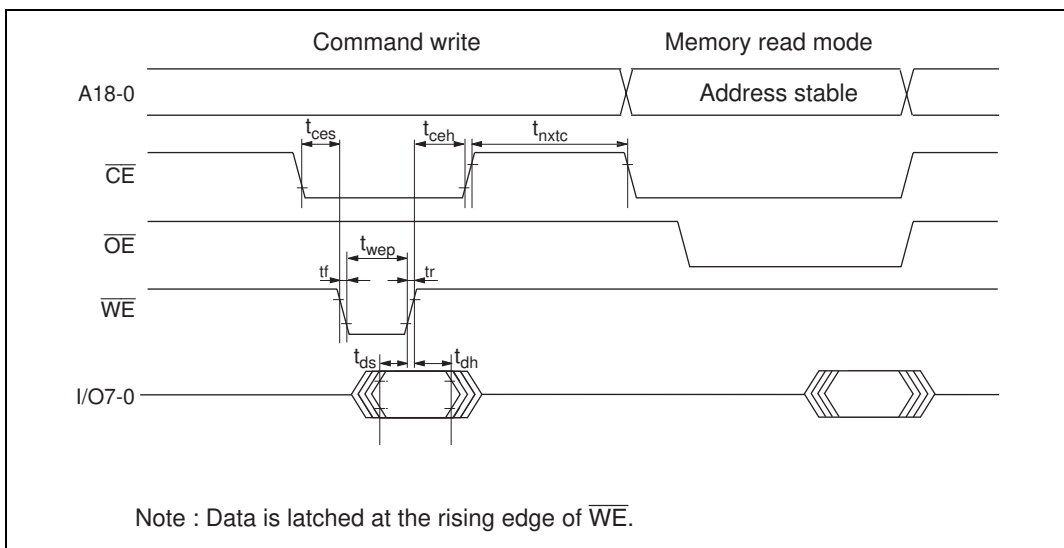

Figure 17.88 Memory Read Timing after Command Write

Table 17.66 AC Characteristics in Transition from Memory Read Mode to OthersCondition: $V_{CC} = 3.3 \text{ V} \pm 0.3 \text{ V}$, $V_{SS} = 0 \text{ V}$, $T_a = 25^\circ\text{C} \pm 5^\circ\text{C}$

Code	Symbol	Min	Max	Unit
Command write cycle	t_{nxtc}	20	—	μs
$\overline{\text{CE}}$ hold time	t_{ceh}	0	—	ns
$\overline{\text{CE}}$ setup time	t_{ces}	0	—	ns
Data hold time	t_{dh}	50	—	ns
Data setup time	t_{ds}	50	—	ns
Programming pulse width	t_{wep}	70	—	ns
$\overline{\text{WE}}$ rise time	t_r	—	30	ns
$\overline{\text{WE}}$ fall time	t_f	—	30	ns

**Figure 17.89 Timing at Transition from Memory Read Mode to Other Modes**

Table 17.67 AC Characteristics Memory Read ModeCondition: $V_{CC} = 3.3\text{ V} \pm 0.3\text{ V}$, $V_{SS} = 0\text{ V}$, $T_a = 25^\circ\text{C} \pm 5^\circ\text{C}$

Code	Symbol	Min	Max	Unit
Access time	t_{acc}	—	20	μs
$\overline{\text{CE}}$ output delay time	t_{ce}	—	150	ns
$\overline{\text{OE}}$ output delay time	t_{oe}	—	150	ns
Output disable delay time	t_{df}	—	100	ns
Data output hold time	t_{oh}	5	—	ns

**Figure 17.90 $\overline{\text{CE}}/\overline{\text{OE}}$ Enable State Read****Figure 17.91 $\overline{\text{CE}}/\overline{\text{OE}}$ Clock Read**

Table 17.69 AC Characteristics Auto-Erase ModeCondition: $V_{CC} = 3.3\text{ V} \pm 0.3\text{ V}$, $V_{SS} = 0\text{ V}$, $T_a = 25^\circ\text{C} \pm 5^\circ\text{C}$

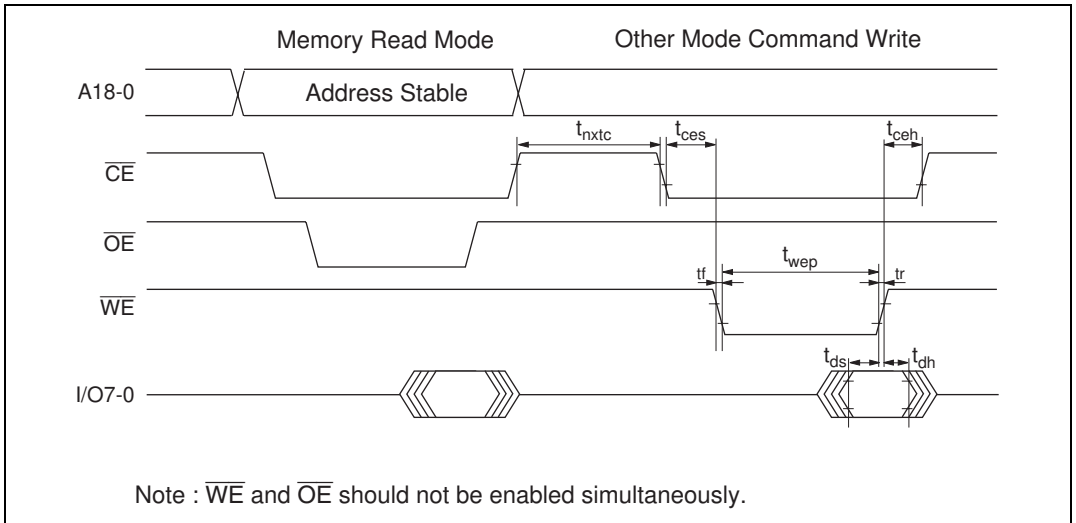
Code	Symbol	Min	Max	Unit
Command write cycle	t_{nxtc}	20	—	μs
$\overline{\text{CE}}$ hold time	t_{ceh}	0	—	ns
$\overline{\text{CE}}$ setup time	t_{ces}	0	—	ns
Data hold time	t_{dh}	50	—	ns
Data setup time	t_{ds}	50	—	ns
Programming pulse width	t_{wep}	70	—	ns
Status polling start time	t_{ests}	1	—	ms
Status polling access time	t_{spa}	—	150	ns
Memory erase time	t_{erase}	100	40000	ms
$\overline{\text{WE}}$ rise time	t_r	—	30	ns
$\overline{\text{WE}}$ fall time	t_f	—	30	ns

**Figure 17.93 Timing in Auto-Erase Mode**

Table 17.70 AC Characteristics Status Read ModeCondition: $V_{CC} = 3.3 \text{ V} \pm 0.3 \text{ V}$, $V_{SS} = 0 \text{ V}$, $T_a = 25^\circ\text{C} \pm 5^\circ\text{C}$

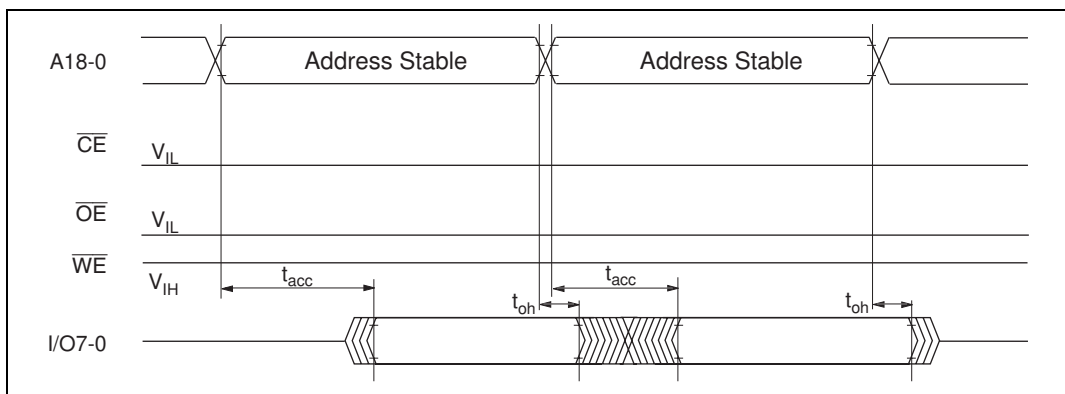
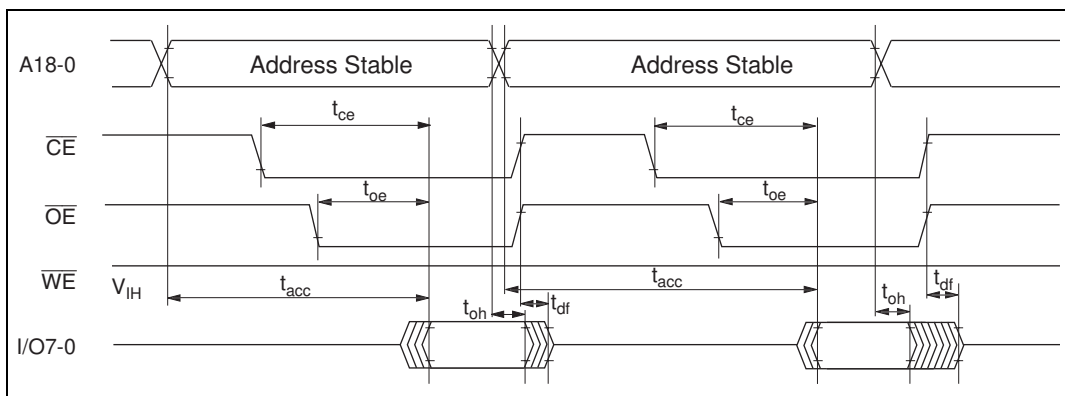
Code	Symbol	Min	Max	Unit
Command write cycle	t_{nxtc}	20	—	μs
$\overline{\text{CE}}$ hold time	t_{ceh}	0	—	ns
$\overline{\text{CE}}$ setup time	t_{ces}	0	—	ns
Data hold time	t_{dh}	50	—	ns
Data setup time	t_{ds}	50	—	ns
Programming pulse width	t_{wep}	70	—	ns
$\overline{\text{OE}}$ output delay time	t_{oe}	—	150	ns
Disable delay time	t_{df}	—	100	ns
$\overline{\text{CE}}$ output delay time	t_{ce}	—	150	ns
$\overline{\text{WE}}$ rise time	t_r	—	30	ns
$\overline{\text{WE}}$ fall time	t_f	—	30	ns

**Figure 17.94 Timing in Status Read Mode****Table 17.71 Stipulated Transition Times to Command Wait State**

Code	Symbol	Min	Max	Unit
Standby release (oscillation settling time)	t_{osc1}	30	—	ms
PROM mode setup time	t_{bmV}	10	—	ms
V_{CC} hold time	t_{dwn}	0	—	ms

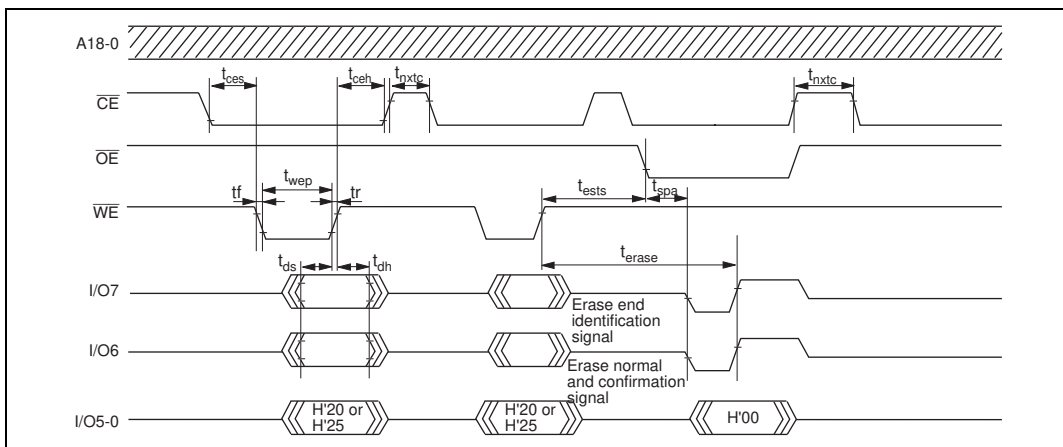
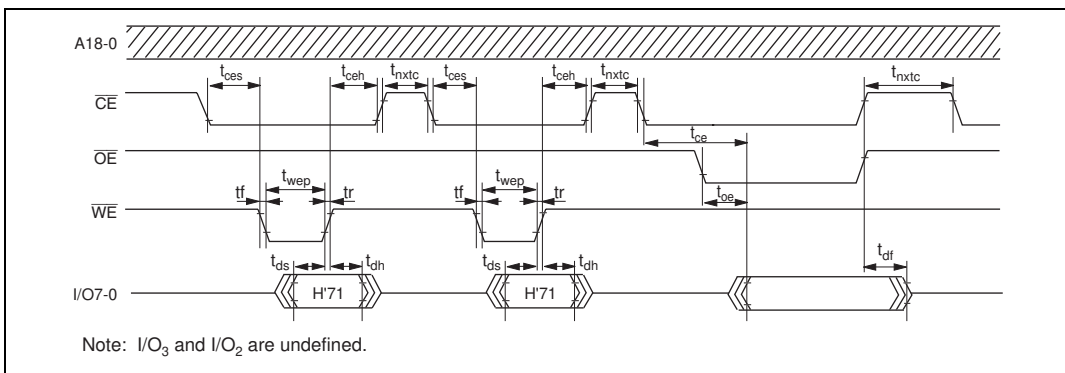
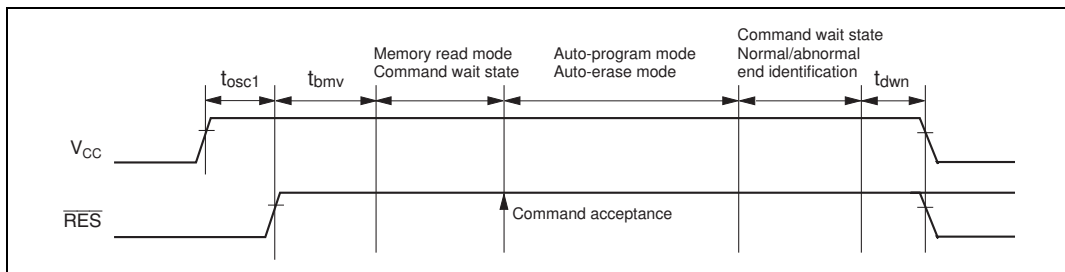

Figure 17.95 Oscillation Stabilization Time, PROM Mode Setup Time, and Power-Down Sequence

17.29.3 Procedure Program and Storable Area for Programming Data

In the descriptions in the previous section, the programming/erasing procedure programs and storable areas for program data are assumed to be in the on-chip RAM. However, the program and the data can be stored in and executed from other areas, such as part of flash memory which is not to be programmed or erased, or somewhere in the external address space.

Conditions that Apply to Programming/Erasing

- (1) The on-chip programming/erasing program is downloaded from the address set by FTDAR in on-chip RAM, therefore, this area is not available for use.
- (2) The on-chip programming/erasing program will use the 128 bytes as a stack. So, make sure that this area is secured.
- (3) Since download by setting the SCO bit to 1 will cause the MATs to be switched, it should be executed in on-chip RAM.
- (4) The flash memory is accessible until the start of programming or erasing, that is, until the result of downloading has been judged. When in a mode in which the external address space is not accessible, such as single-chip mode, the required procedure programs should be transferred to the on-chip RAM before programming/erasing of the flash memory starts.
- (5) The flash memory is not accessible during programming/erasing operations, therefore, the operation program is downloaded to the on-chip RAM to be executed. The programs such as that which activate the operation program, should thus be stored in on-chip memory other than flash memory or the external address space.
- (6) After programming/erasing, the flash memory should be inhibited until FKEY is cleared. The reset state ($RES = 0$) must be in place for more than $100 \mu s$ when the LSI mode is changed to reset on completion of a programming/erasing operation.

Transitions to the reset state, and hardware standby mode are inhibited during programming/erasing. When the reset signal is accidentally input to the chip, a longer period in the reset state than usual (100 μ s) is needed before the reset signal is released.

- (7) Switching of the MATs by FMATS should be needed when programming/erasing of the user boot MAT is operated in user-boot mode. The program which switches the MATs should be executed from the on-chip RAM. See section 17.27, Switching between User MAT and User Boot MAT. Please make sure you know which MAT is selected when switching between them.
- (8) When the data storable area indicated by programming parameter FMPDR is within the flash memory area, an error will occur even when the data stored is normal. Therefore, the data should be transferred to the on-chip RAM to place the address that FMPDR indicates in an area other than the flash memory.

In consideration of these conditions, there are three factors; operating mode, the bank structure of the user MAT, and operations.

The areas in which the programming data can be stored for execution are shown in table 17.26.

Table 17.72 Executable MAT

Operation	Initiated Modes	
	User Program Mode	User Boot Mode*
Programming	Table 17.73 (1)	Table 17.73 (3)
Erasing	Table 17.73 (2)	Table 17.73 (4)

Note: * Programming/Erasing is possible to user MATs.

Table 17.73 (1) Usable Area for Programming in User Program Mode

	Item	Storable/Executable Area			Selected MAT	
		On-Chip RAM	User MAT	External Space (Expanded Mode)	User MAT	Embedded Program Storage Area
Programming Procedure ↓	Storage Area for Program Data	○	×*	○	—	—
	Operation for Selection of On-Chip Program to be Downloaded	○	○	○	○	
	Operation for Writing H'A5 to Key Register	○	○	○	○	
	Execution of Writing SC0 = 1 to FCCS (Download)	○	×	×		○
	Operation for Key Register Clear	○	○	○	○	
	Judgement of Download Result	○	○	○	○	
	Operation for Download Error	○	○	○	○	
	Operation for Settings of Initial Parameter	○	○	○	○	
	Execution of Initialization	○	×	×	○	
	Judgement of Initialization Result	○	○	○	○	
	Operation for Initialization Error	○	○	○	○	
	Operation for Inhibit of Interrupt	○	○	○	○	
	Operation for Writing H'5A to Key Register	○	○	○	○	
	Operation for Settings of Program Parameter	○	×	○	○	
	Execution of Programming	○	×	×	○	
	Judgement of Program Result	○	×	○	○	
	Operation for Program Error	○	×	○	○	
	Operation for Key Register Clear	○	×	○	○	

Note: * Transferring the data to the on-chip RAM enables this area to be used.

Table 17.73 (2) Usable Area for Erasure in User Program Mode

	Item	Storable/Executable Area			Selected MAT	
		On-Chip RAM	User MAT	External Space (Expanded Mode)	User MAT	Embedded Program Storage Area
Erasing Procedure ↓	Operation for Selection of On-Chip Program to be Downloaded	○	○	○	○	
	Operation for Writing H'A5 to Key Register	○	○	○	○	
	Execution of Writing SC0 = 1 to FCCS (Download)	○	×	×		○
	Operation for Key Register Clear	○	○	○	○	
	Judgement of Download Result	○	○	○	○	
	Operation for Download Error	○	○	○	○	
	Operation for Settings of Default Parameter	○	○	○	○	
	Execution of Initialization	○	×	×	○	
	Judgement of Initialization Result	○	○	○	○	
	Operation for Initialization Error	○	○	○	○	
	Operation for Inhibit of Interrupt	○	○	○	○	
	Operation for Writing H'5A to Key Register	○	○	○	○	
	Operation for Settings of Erasure Parameter	○	×	○	○	
	Execution of Erasure	○	×	×	○	
	Judgement of Erasure Result	○	×	○	○	
	Operation for Erasure Error	○	×	○	○	
Operation for Key Register Clear	○	×	○	○		

Table 17.73 (3) Usable Area for Programming in User Boot Mode

	Item	Storable/Executable Area			Selected MAT		
		On-Chip RAM	User Boot MAT	External Space (Expanded Mode)	User MAT	User Boot MAT	Embedded Program Storage Area
Programming procedure	Storage Area for Program Data	○	× ^{*1}	○	—	—	—
	Operation for Selection of On-Chip Program to be Downloaded	○	○	○		○	
	Operation for Writing H'A5 to Key Register	○	○	○		○	
	Execution of Writing SC0 = 1 to FCCS (Download)	○	×	×			○
	Operation for Key Register Clear	○	○	○		○	
	Judgement of Download Result	○	○	○		○	
	Operation for Download Error	○	○	○		○	
	Operation for Settings of Default Parameter	○	○	○		○	
	Execution of Initialization	○	×	×		○	
	Judgement of Initialization Result	○	○	○		○	
	Operation for Initialization Error	○	○	○		○	
	Operation for Interrupt Inhibit	○	○	○		○	
	Switching MATs by FMATS	○	×	×	○		
	Operation for Writing H'5A to Key Register	○	×	○	○		
	Operation for Settings of Program Parameter	○	×	○	○		
	Execution of Programming	○	×	×	○		
	Judgement of Program Result	○	×	○	○		
	Operation for Program Error	○	× ^{*2}	○	○		
	Operation for Key Register Clear	○	×	○	○		
	Switching MATs by FMATS	○	×	×		○	

Notes: 1. Transferring the data to the on-chip RAM enables this area to be used.

2. Switching FMATS by a program in the on-chip RAM enables this area to be used.

Table 17.73 (4) Usable Area for Erasure in User Boot Mode

	Item	Storable/Executable Area			Selected MAT		
		On-Chip RAM	User Boot MAT	External Space (Expanded Mode)	User MAT	User Boot MAT	Embedded Program Storage Area
Erasing Procedure	Operation for Selection of On-Chip Program to be Downloaded	○	○	○		○	
	Operation for Writing H'A5 to Key Register	○	○	○		○	
	Execution of Writing SC0 = 1 to FCCS (Download)	○	×	×			○
	Operation for Key Register Clear	○	○	○		○	
	Judgement of Download Result	○	○	○		○	
	Operation for Download Error	○	○	○		○	
	Operation for Settings of Default Parameter	○	○	○		○	
	Execution of Initialization	○	×	×		○	
	Judgement of Initialization Result	○	○	○		○	
	Operation for Initialization Error	○	○	○		○	
	Operation for Interrupt Inhibit	○	○	○		○	
	Switching MATs by FMATS	○	×	×		○	
	Operation for Writing H'5A to Key Register	○	×	○	○		
	Operation for Settings of Erasure Parameter	○	×	○	○		
	Execution of Erasure	○	×	×	○		
	Judgement of Erasure Result	○	×	○	○		
	Operation for Erasure Error	○	×*	○	○		
	Operation for Key Register Clear	○	×	○	○		
	Switching MATs by FMATS	○	×	×		○	

Note: *Switching FMATS by a program in the on-chip RAM enables this area to be used.

Section 18 Clock Pulse Generator

18.1 Overview

The chip has an on-chip clock pulse generator (CPG) that generates the system clock (ϕ), the bus master clock, and internal clocks.

The clock pulse generator consists of an oscillator circuit, a duty adjustment circuit, a medium-speed clock divider, and a bus master clock selection circuit.

In the chip, the CPG has a medium-speed mode in which the bus master runs on a medium-speed clock and the other supporting modules run on the high-speed clock, and a function that allows the medium-speed mode to be disabled and the clock division ratio to be changed for the entire chip. A clock from $\phi/2$ to $\phi/32$ can be selected.

18.1.1 Block Diagram

Figure 18.1 shows a block diagram of the clock pulse generator.

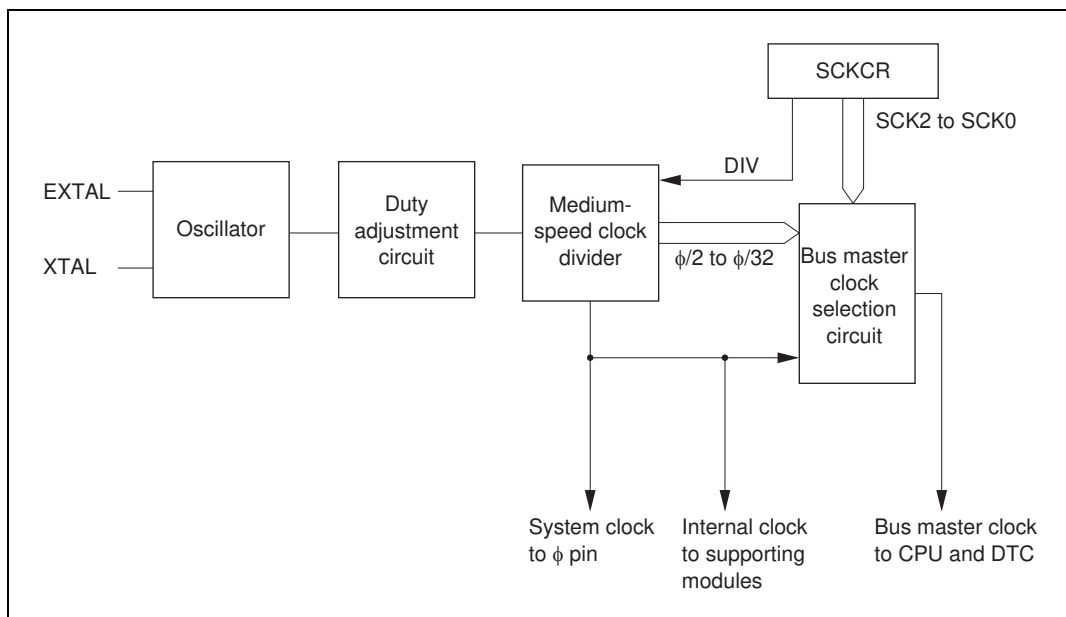

Figure 18.1 Block Diagram of Clock Pulse Generator

18.1.2 Register Configuration

The clock pulse generator is controlled by SCKCR. Table 18.1 shows the register configuration.

Table 18.1 Clock Pulse Generator Register

Name	Abbreviation	R/W	Initial Value	Address*
System clock control register	SCKCR	R/W	H'00	H'FF3A

Note: * Lower 16 bits of the address.

18.2 Register Descriptions

18.2.1 System Clock Control Register (SCKCR)

Bit	:	7	6	5	4	3	2	1	0
		PSTOP	—	DIV	—	—	SCK2	SCK1	SCK0
Initial value :		0	0	0	0	0	0	0	0
R/W	:	R/W	R/W	R/W	—	—	R/W	R/W	R/W

SCKCR is an 8-bit readable/writable register that controls ϕ clock output, the medium-speed mode in which the bus master runs on a medium-speed clock and the other supporting modules run on the high-speed clock, and a function that allows the medium-speed mode to be disabled and the clock division ratio to be changed for the entire chip.

SCKCR is initialized to H'00 by a reset and in hardware standby mode. It is not initialized in software standby mode.

Bit 7— ϕ Clock Output Disable (PSTOP): Controls ϕ output.

Bit 7 PSTOP	Description			
	Normal Operation	Sleep Mode	Software Standby Mode	Hardware Standby Mode
0	ϕ output (Initial value)	ϕ output	Fixed high	High impedance
1	Fixed high	Fixed high	Fixed high	High impedance

Bit 6—Reserved: This bit can be read or written to, but only 0 should be written.

Bit 5—Division Ratio Select (DIV): When the DIV bit is set to 1, the medium-speed mode is disabled and a clock obtained using the division ratio set with bits SCK2 to SCK0 is supplied to the entire chip. In this way, the current dissipation within the chip is reduced in proportion to the division ratio. As the frequency of ϕ changes, the following points must be noted.

- The division ratio set with bits SCK2 to SCK0 should be selected so as to fall within the guaranteed operation range of clock cycle time t_{cyc} given in the AC timing table in the Electrical Characteristics section. Ensure that $\phi_{min} = 2$ MHz, and the condition $\phi < 2$ MHz does not arise.
- All internal modules basically operate on ϕ . Note, therefore, that time processing involving the timers, the SCI, etc., will change when the division ratio changes. The wait time when software standby is cleared will also change in line with a change in the division ratio.
- The division ratio can be changed while the chip is operating. The clock output from the ϕ pin will also change when the division ratio is changed. The frequency of the clock output from the ϕ pin in this case will be as follows:

$$\phi = \text{EXTAL} \times n$$

Where: EXTAL: Crystal resonator or external clock frequency

n: Division ratio ($n = \phi/2, \phi/4, \text{ or } \phi/8$)

- Do not set the DIV bit and bits SCK2 to SCK0 simultaneously. First set the DIV bit, then bits SCK2 to SCK0.

Bit 5

DIV	Description
0	When bits SCK2 to SCK0 are set to other than high-speed mode, medium-speed mode is set (Initial value)
1	When bits SCK2 to SCK0 are set to other than high-speed mode, a divided clock is supplied to the entire chip

Bits 4 and 3—Reserved: These bits cannot be modified and are always read as 0.

Bits 2 to 0—System Clock Select 2 to 0 (SCK2 to SCK0): When the DIV bit is cleared to 0, these bits select the medium-speed mode; when the DIV bit is set to 1, they select the division ratio of the clock supplied to the entire chip.

Bit 2 SCK2	Bit 1 SCK1	Bit 0 SCK0	Description	
			DIV = 0	DIV = 1
0	0	0	Bus master is in high-speed mode (Initial value)	Bus master is in high-speed mode (Initial value)
		1	Medium-speed clock is $\phi/2$	Clock supplied to entire chip is $\phi/2$
	1	0	Medium-speed clock is $\phi/4$	Clock supplied to entire chip is $\phi/4$
		1	Medium-speed clock is $\phi/8$	Clock supplied to entire chip is $\phi/8$
1	0	0	Medium-speed clock is $\phi/16$	—
		1	Medium-speed clock is $\phi/32$	—
	1	—	—	—

18.3 Oscillator

Clock pulses can be supplied by connecting a crystal resonator, or by input of an external clock.

18.3.1 Connecting a Crystal Resonator

Circuit Configuration: A crystal resonator can be connected as shown in the example in figure 18.2. Select the damping resistance R_d according to table 18.2. An AT-cut parallel-resonance crystal should be used.

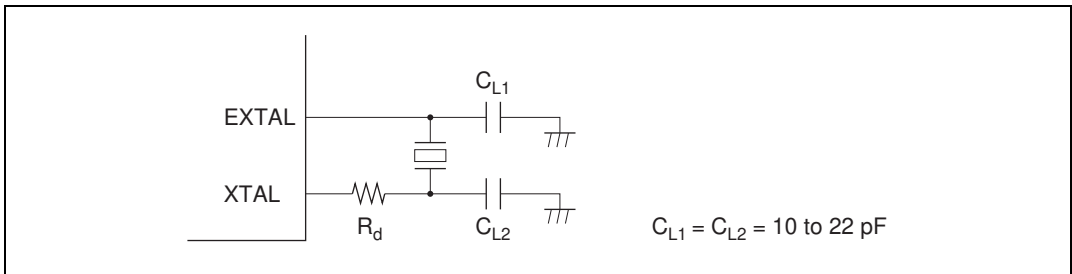

Figure 18.2 Connection of Crystal Resonator (Example)

Table 18.2 Damping Resistance Value

Frequency (MHz)	2	4	8	12	16	20	25
R_d (Ω)	6.8 k	500	200	0	0	0	0

Crystal Resonator: Figure 18.3 shows the equivalent circuit of the crystal resonator. Use a crystal resonator that has the characteristics shown in table 18.3 and the same resonance frequency as the system clock (ϕ).

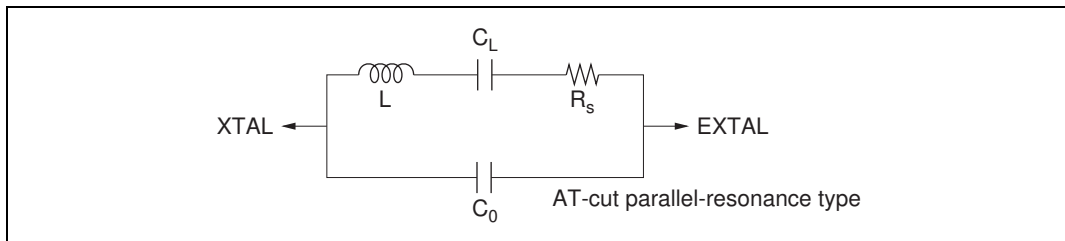

Figure 18.3 Crystal Resonator Equivalent Circuit

Table 18.3 Crystal Resonator Characteristics

Frequency (MHz)	2	4	8	12	16	20	25
R_s max (Ω)	500	120	80	60	50	40	40
C_0 max (pF)	7	7	7	7	7	7	7

Notes on Board Design: When a crystal resonator is connected, the following points should be noted:

Other signal lines should be routed away from the oscillator circuit to prevent induction from interfering with correct oscillation. See figure 18.4.

When designing the board, place the crystal resonator and its load capacitors as close as possible to the XTAL and EXTAL pins.

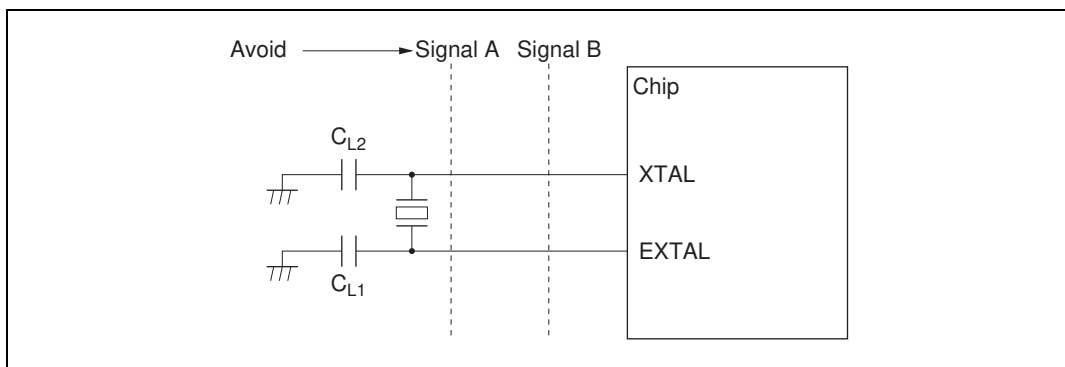

Figure 18.4 Example of Incorrect Board Design

18.3.2 External Clock Input

Circuit Configuration: An external clock signal can be input as shown in the examples in figure 18.5. If the XTAL pin is left open, make sure that stray capacitance is no more than 10 pF.

In example (b), make sure that the external clock is held high in standby mode.

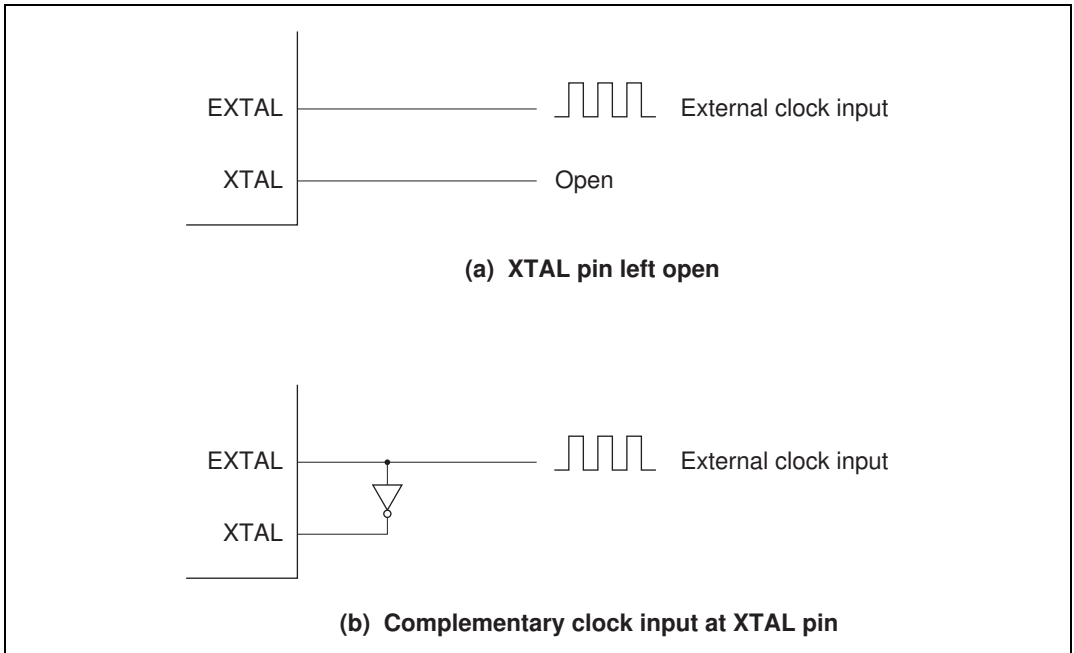

Figure 18.5 External Clock Input (Examples)

External Clock: The external clock signal should have the same frequency as the system clock (ϕ).

Table 18.4 and figure 18.6 show the input conditions for the external clock.

Table 18.4 External Clock Input Conditions

Item	Symbol	$V_{CC} = 2.7\text{ V}$ to 3.3 V		$V_{CC} = 3.0\text{ V}$ to 3.6 V		Unit	Test Conditions
		Min	Max	Min	Max		
External clock input low pulse width	t_{EXL}	20	—	10	—	ns	Figure 18.6
External clock input high pulse width	t_{EXH}	20	—	10	—	ns	
External clock rise time	t_{EXr}	—	5	—	5	ns	
External clock fall time	t_{EXf}	—	5	—	5	ns	
Clock low pulse width level	t_{CL}	0.4	0.6	0.4	0.6	t_{cyc}	$\phi \geq 5\text{ MHz}$
		80	—	80	—	ns	$\phi < 5\text{ MHz}$
Clock high pulse width level	t_{CH}	0.4	0.6	0.4	0.6	t_{cyc}	$\phi \geq 5\text{ MHz}$
		80	—	80	—	ns	$\phi < 5\text{ MHz}$

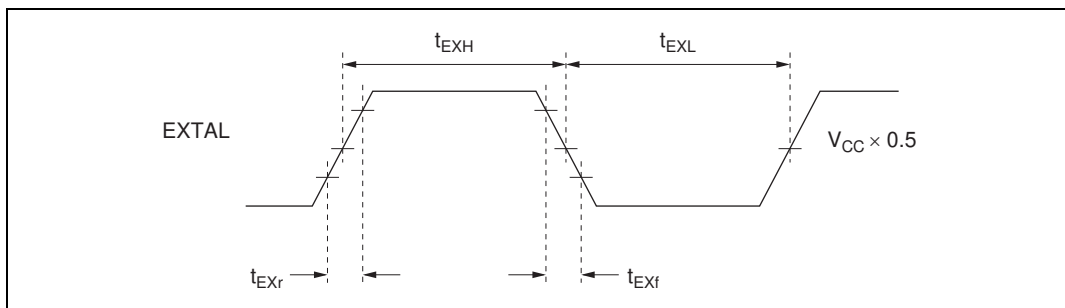

Figure 18.6 External Clock Input Timing

18.4 Duty Adjustment Circuit

When the oscillator frequency is 5 MHz or higher, the duty adjustment circuit adjusts the duty cycle of the clock signal from the oscillator to generate the system clock (ϕ).

18.5 Medium-Speed Clock Divider

The medium-speed clock divider divides the system clock to generate $\phi/2$, $\phi/4$, $\phi/8$, $\phi/16$, and $\phi/32$.

18.6 Bus Master Clock Selection Circuit

The bus master clock selection circuit selects the system clock (ϕ) or one of the medium-speed clocks ($\phi/2$, $\phi/4$, $\phi/8$, $\phi/16$, or $\phi/32$) to be supplied to the bus master, according to the settings of the SCK2 to SCK0 bits in SCKCR.

Section 19 Power-Down Modes

19.1 Overview

In addition to the normal program execution state, the chip has five power-down modes in which operation of the CPU and oscillator is halted and power dissipation is reduced. Low-power operation can be achieved by individually controlling the CPU, on-chip supporting modules, and so on.

The chip operating modes are as follows:

1. High-speed mode
2. Medium-speed mode
3. Sleep mode
4. Module stop mode
5. Software standby mode
6. Hardware standby mode

Of these, 2 to 6 are power-down modes. Sleep mode is a CPU mode, medium-speed mode is a CPU and bus master mode, and module stop mode is an on-chip supporting module mode (including bus masters other than the CPU). A combination of these modes can be set.

After a reset, the chip is in high-speed mode.

Table 19.1 shows the conditions for transition to the various modes, the status of the CPU, on-chip supporting modules, etc., and the method of clearing each mode.

Table 19.1 Operating Modes

Operating Mode	Transition Condition	Clearing Condition	Oscillator	CPU		Modules		I/O Ports
					Registers	Registers		
High speed mode	Control register	Control register	Functions	High speed	Function	High speed	Function	High speed
Medium-speed mode	Control register	Control register	Functions	Medium speed	Function	High/medium speed ^{*1}	Function	High speed
Sleep mode	Instruction	Interrupt	Functions	Halted	Retained	High speed	Function	High speed
Module stop mode	Control register	Control register	Functions	High/medium speed	Function	Halted	Retained/reset ^{*2}	Retained
Software standby mode	Instruction	External interrupt	Halted	Halted	Retained	Halted	Retained/reset ^{*2}	Retained
Hardware standby mode	Pin	Pin	Halted	Halted	Undefined	Halted	Reset	High impedance

- Notes: 1. The bus master operates on the medium-speed clock, and other on-chip supporting modules on the high-speed clock.
2. Some SCI registers and the A/D converter are reset, and other on-chip supporting modules retain their states.

19.1.1 Register Configuration

Power-down modes are controlled by the SBYCR, SCKCR, and MSTPCR registers. Table 19.2 summarizes these registers.

Table 19.2 Power-Down Mode Registers

Name	Abbreviation	R/W	Initial Value	Address*
Standby control register	SBYCR	R/W	H'08	H'FF38
System clock control register	SCKCR	R/W	H'00	H'FF3A
Module stop control register H	MSTPCRH	R/W	H'3F	H'FF3C
Module stop control register L	MSTPCRL	R/W	H'FF	H'FF3D

Note: * Lower 16 bits of the address.

19.2 Register Descriptions

19.2.1 Standby Control Register (SBYCR)

Bit	:	7	6	5	4	3	2	1	0
		SSBY	STS2	STS1	STS0	OPE	—	—	IRQ37S
Initial value :		0	0	0	0	1	0	0	0
R/W	:	R/W	R/W	R/W	R/W	R/W	—	—	R/W

SBYCR is an 8-bit readable/writable register that performs software standby mode control.

SBYCR is initialized to H'08 by a reset and in hardware standby mode. It is not initialized in software standby mode.

Bit 7—Software Standby (SSBY): Specifies a transition to software standby mode. Remains set to 1 when software standby mode is released by an external interrupt, and a transition is made to normal operation. The SSBY bit should be cleared by writing 0 to it.

Bit 7

SSBY	Description
0	Transition to sleep mode after execution of SLEEP instruction (Initial value)
1	Transition to software standby mode after execution of SLEEP instruction

Bits 6 to 4—Standby Timer Select 2 to 0 (STS2 to STS0): These bits select the time the MCU waits for the clock to stabilize when software standby mode is cleared by an external interrupt. With crystal oscillation, refer to table 19.4 and make a selection according to the operating frequency so that the standby time is at least 8 ms (the oscillation stabilization time). With an external clock, any selection can be made*.

Note: * Except in the F-ZTAT versions.

Bit 6 STS2	Bit 5 STS1	Bit 4 STS0	Description
0	0	0	Standby time = 8192 states (Initial value)
		1	Standby time = 16384 states
	1	0	Standby time = 32768 states
		1	Standby time = 65536 states
1	0	0	Standby time = 131072 states
		1	Standby time = 262144 states
	1	0	Reserved
		1	Standby time = 16 states*

Note: *Not available in the F-ZTAT versions.

Bit 3—Output Port Enable (OPE): Specifies whether the output of the address bus and bus control signals ($\overline{CS0}$ to $\overline{CS7}$, \overline{AS} , \overline{RD} , \overline{HWR} , \overline{LWR} , \overline{CAS}) is retained or set to the high-impedance state in software standby mode.

Bit 3 OPE	Description
0	In software standby mode, address bus and bus control signals are high-impedance
1	In software standby mode, address bus and bus control signals retain output state (Initial value)

Bits 2 and 1—Reserved: These bits cannot be modified and are always read as 0.

Bit 0—IRQ37 Software Standby Clear Select (IRQ37S): Specifies whether inputs $\overline{IRQ3}$ to $\overline{IRQ7}$ can be used as software standby mode clearing sources in addition to the usual sources, NMI and $\overline{IRQ0}$ to $\overline{IRQ2}$ inputs.

Bit 0 IRQ37S	Description
0	Inputs $\overline{IRQ3}$ to $\overline{IRQ7}$ cannot be used as software standby mode clearing sources (Initial value)
1	Inputs $\overline{IRQ3}$ to $\overline{IRQ7}$ can be used as software standby mode clearing sources

19.2.2 System Clock Control Register (SCKCR)

Bit	:	7	6	5	4	3	2	1	0
		PSTOP	—	DIV	—	—	SCK2	SCK1	SCK0
Initial value	:	0	0	0	0	0	0	0	0
R/W	:	R/W	R/W	R/W	—	—	R/W	R/W	R/W

SCKCR is an 8-bit readable/writable register that controls ϕ clock output, the medium-speed mode in which the bus master runs on a medium-speed clock and the other supporting modules run on the high-speed clock, and a function that allows the medium-speed mode to be disabled and the clock division ratio to be changed for the entire chip.

SCKCR is initialized to H'00 by a reset and in hardware standby mode. It is not initialized in software standby mode.

Bit 7— ϕ Clock Output Disable (PSTOP): Controls ϕ output.

Bit 7 PSTOP	Description			
	Normal Operating Mode	Sleep Mode	Software Standby Mode	Hardware Standby Mode
0	ϕ output (Initial value)	ϕ output	Fixed high	High impedance
1	Fixed high	Fixed high	Fixed high	High impedance

Bit 6—Reserved: This bit can be read or written to, but only 0 should be written.

Bit 5—Division Ratio Select (DIV): When the DIV bit is set to 1, the medium-speed mode is disabled and a clock obtained using the division ratio set with bits SCK2 to SCK0 is supplied to the entire chip. In this way, the current dissipation within the chip is reduced in proportion to the division ratio. As the frequency of ϕ changes, the following points must be noted.

- The division ratio set with bits SCK2 to SCK0 should be selected so as to fall within the guaranteed operation range of clock cycle time t_{cyc} given in the AC timing table in the Electrical Characteristics section. Ensure that $\phi_{min} = 2$ MHz, and the condition $\phi < 2$ MHz does not arise.
- All internal modules basically operate on ϕ . Note, therefore, that time processing involving the timers, the SCI, etc., will change when the division ratio changes. The wait time when software standby is cleared will also change in line with a change in the division ratio.

- The division ratio can be changed while the chip is operating. The clock output from the ϕ pin will also change when the division ratio is changed. The frequency of the clock output from the ϕ pin in this case will be as follows:

$$\phi = \text{EXTAL} \times n$$

Where: EXTAL: Crystal resonator or external clock frequency

n: Division ratio ($n = \phi/2, \phi/4, \text{ or } \phi/8$)

- Do not set the DIV bit and bits SCK2 to SCK0 simultaneously. First set the DIV bit, then bits SCK2 to SCK0.

Bit 5

Bit 5 DIV	Description
0	When bits SCK2 to SCK0 are set to other than high-speed mode, medium-speed mode is set (Initial value)
1	When bits SCK2 to SCK0 are set to other than high-speed mode, a divided clock is supplied to the entire chip

Bits 4 and 3—Reserved: These bits cannot be modified and are always read as 0.

Bits 2 to 0—System Clock Select 2 to 0 (SCK2 to SCK0): When the DIV bit is cleared to 0, these bits select the bus master clock; when the DIV bit is set to 1, they select the division ratio of the clock supplied to the entire chip.

Bit 2 SCK2	Bit 1 SCK1	Bit 0 SCK0	Description	
			DIV = 0	DIV = 1
0	0	0	Bus master is in high-speed mode (Initial value)	Bus master is in high-speed mode (Initial value)
		1	Medium-speed clock is $\phi/2$	Clock supplied to entire chip is $\phi/2$
	1	0	Medium-speed clock is $\phi/4$	Clock supplied to entire chip is $\phi/4$
		1	Medium-speed clock is $\phi/8$	Clock supplied to entire chip is $\phi/8$
1	0	0	Medium-speed clock is $\phi/16$	—
		1	Medium-speed clock is $\phi/32$	—
	1	—	—	—

19.2.3 Module Stop Control Register (MSTPCR)

MSTPCRH								MSTPCRL									
Bit	:	15	14	13	12	11	10	9	8	7	6	5	4	3	2	1	0
Initial value	:	0	0	1	1	1	1	1	1	1	1	1	1	1	1	1	1
R/W	:	R/W	R/W	R/W	R/W	R/W	R/W	R/W	R/W	R/W	R/W	R/W	R/W	R/W	R/W	R/W	R/W

MSTPCR is a 16-bit readable/writable register that performs module stop mode control.

MSTPCR is initialized to H'3FFF by a reset and in hardware standby mode. It is not initialized in software standby mode.

Bits 15 to 0—Module Stop (MSTP 15 to MSTP 0): These bits specify module stop mode. See table 19.3 for the method of selecting on-chip supporting modules.

Bits 15 to 0

MSTP15 to MSTP0	Description
0	Module stop mode cleared
1	Module stop mode set

19.3 Medium-Speed Mode

When the SCK2 to SCK0 bits in SCKCR are set to 1, the operating mode changes to medium-speed mode as soon as the current bus cycle ends. In medium-speed mode, the CPU operates on the operating clock ($\phi/2$, $\phi/4$, $\phi/8$, $\phi/16$, or $\phi/32$) specified by the SCK2 to SCK0 bits. The bus masters other than the CPU (the DTC) also operate in medium-speed mode. On-chip supporting modules other than the bus masters always operate on the high-speed clock (ϕ).

In medium-speed mode, a bus access is executed in the specified number of states with respect to the bus master operating clock. For example, if $\phi/4$ is selected as the operating clock, on-chip memory is accessed in 4 states, and internal I/O registers in 8 states.

Medium-speed mode is cleared by clearing all of bits SCK2 to SCK0 to 0. A transition is made to high-speed mode and medium-speed mode is cleared at the end of the current bus cycle.

If a SLEEP instruction is executed when the SSBY bit in SBYCR is cleared to 0, a transition is made to sleep mode. When sleep mode is cleared by an interrupt, medium-speed mode is restored.

If a SLEEP instruction is executed when the SSBY bit in SBYCR is set to 1, a transition is made to software standby mode. When software standby mode is cleared by an external interrupt, medium-speed mode is restored.

When the $\overline{\text{RES}}$ pin is driven low, a transition is made to the reset state, and medium-speed mode is cleared. The same applies in the case of a reset caused by overflow of the watchdog timer.

When the $\overline{\text{STBY}}$ pin is driven low, a transition is made to hardware standby mode.

Figure 19.1 shows the timing for transition to and clearance of medium-speed mode.

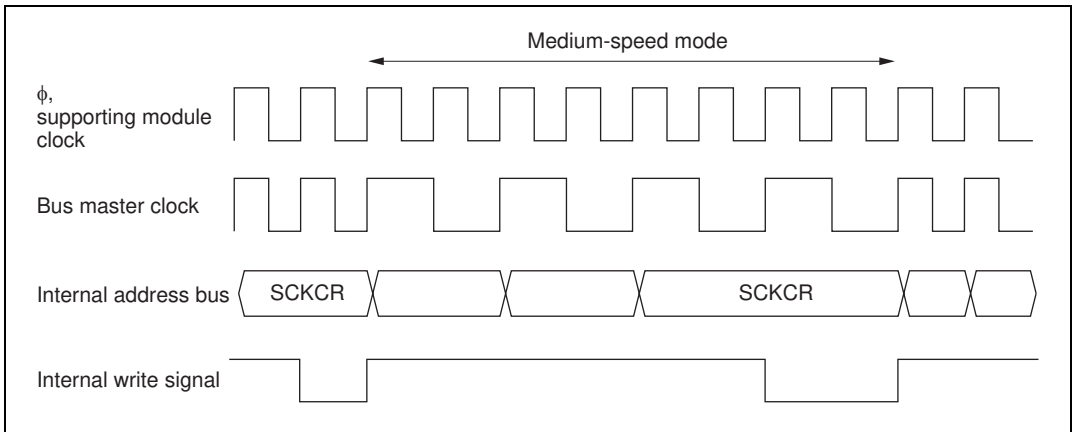

Figure 19.1 Medium-Speed Mode Transition and Clearance Timing

19.4 Sleep Mode

If a SLEEP instruction is executed when the SSBY bit in SBYCR is cleared to 0, the CPU enters sleep mode. In sleep mode, CPU operation stops but the contents of the CPU's internal registers are retained. Other supporting modules do not stop.

Sleep mode is cleared by a reset or any interrupt, and the CPU returns to the normal program execution state via the exception handling state. Sleep mode is not cleared if interrupts are disabled, or if interrupts other than NMI are masked by the CPU.

When the $\overline{\text{STBY}}$ pin is driven low, a transition is made to hardware standby mode.

19.5 Module Stop Mode

19.5.1 Module Stop Mode

Module stop mode can be set for individual on-chip supporting modules.

When the corresponding MSTP bit in MSTPCR is set to 1, module operation stops at the end of the bus cycle and a transition is made to module stop mode. The CPU continues operating independently.

Table 19.3 shows MSTP bits and the corresponding on-chip supporting modules.

When the corresponding MSTP bit is cleared to 0, module stop mode is cleared and the module starts operating at the end of the bus cycle. In module stop mode, the internal states of modules other than the SCI and A/D converter are retained.

After reset clearance, all modules other than DTC are in module stop mode.

When an on-chip supporting module is in module stop mode, read/write access to its registers is disabled.

Do not make a transition to sleep mode with MSTPCR set to H'FFFF or H'EFFF, as this will halt operation of the bus controller.

Table 19.3 MSTP Bits and Corresponding On-Chip Supporting Modules

Register	Bit	Module
MSTPCRH	MSTP15	—
	MSTP14	Data transfer controller (DTC)
	MSTP13	16-bit timer-pulse unit (TPU)
	MSTP12	8-bit timer module
	MSTP11	—
	MSTP10	D/A converter (channels 0 and 1)
	MSTP9	A/D converter
	MSTP8	—
MSTPCRL	MSTP7	—
	MSTP6	Serial communication interface (SCI) channel 1
	MSTP5	Serial communication interface (SCI) channel 0
	MSTP4	—
	MSTP3	—
	MSTP2	—
	MSTP1	—
	MSTP0	—

Note: Bits 15, 11, 8, 7, and 4 to 0 can be read or written to, but do not affect operation.

19.5.2 Usage Notes

DTC Module Stop: Depending on the operating status of the DTC, the MSTP14 bit may not be set to 1. Setting of the DTC module stop mode should be carried out only when the module is not activated.

For details, refer to section 7, Data Transfer Controller.

On-Chip Supporting Module Interrupts: Relevant interrupt operations cannot be performed in module stop mode. Consequently, if module stop mode is entered when an interrupt has been requested, it will not be possible to clear the CPU interrupt source or the DTC activation source. Interrupts should therefore be disabled before entering module stop mode.

Writing to MSTPCR: MSTPCR should only be written to by the CPU.

19.6 Software Standby Mode

19.6.1 Software Standby Mode

If a SLEEP instruction is executed when the SSBY bit in SBYCR is set to 1, software standby mode is entered. In this mode, the CPU, on-chip supporting modules, and oscillator all stop. However, the contents of the CPU's internal registers, RAM data, and the states of on-chip supporting modules other than the SCI and A/D converter, and I/O ports, are retained. Whether the address bus and bus control signals are placed in the high-impedance state or retain the output state can be specified by the OPE bit in SBYCR. See appendix D, Pin States, for details.

In this mode the oscillator stops, and therefore power dissipation is significantly reduced.

19.6.2 Clearing Software Standby Mode

Software standby mode is cleared by an external interrupt (NMI pin, or pins $\overline{\text{IRQ0}}$ to $\overline{\text{IRQ7}}^*$), or by means of the $\overline{\text{RES}}$ pin or $\overline{\text{STBY}}$ pin.

Clearing with an Interrupt: When an NMI or $\overline{\text{IRQ0}}$ to $\overline{\text{IRQ7}}^*$ interrupt request signal is input, clock oscillation starts, and after the elapse of the time set in bits STS2 to STS0 in SYSCR, stable clocks are supplied to the entire chip, software standby mode is cleared, and interrupt exception handling is started.

When clearing software standby mode with an $\overline{\text{IRQ0}}$ to $\overline{\text{IRQ7}}^*$ interrupt, set the corresponding enable bit to 1 and ensure that no interrupt with a higher priority than interrupts $\overline{\text{IRQ0}}$ to $\overline{\text{IRQ7}}^*$ is generated. Software standby mode cannot be cleared if the interrupt has been masked on the CPU side or has been designated as a DTC activation source.

Note: * Setting the $\overline{\text{IRQ37S}}$ bit to 1 enables $\overline{\text{IRQ3}}$ to $\overline{\text{IRQ7}}$ to be used as software standby mode clearing sources.

Clearing with the $\overline{\text{RES}}$ Pin: When the $\overline{\text{RES}}$ pin is driven low, clock oscillation is started. At the same time as clock oscillation starts, clocks are supplied to the entire chip. Note that the $\overline{\text{RES}}$ pin must be held low until clock oscillation stabilizes. When the $\overline{\text{RES}}$ pin goes high, the CPU begins reset exception handling.

Clearing with the $\overline{\text{STBY}}$ Pin: When the $\overline{\text{STBY}}$ pin is driven low, a transition is made to hardware standby mode.

19.6.3 Setting Oscillation Stabilization Time after Clearing Software Standby Mode

Bits STS2 to STS0 in SBYCR should be set as described below.

Using a Crystal Oscillator: Set bits STS2 to STS0 so that the standby time is at least 8 ms (the oscillation stabilization time).

Table 19.4 shows the standby times for different operating frequencies and settings of bits STS2 to STS0.

Table 19.4 Oscillation Stabilization Time Settings

STS2	STS1	STS0	Standby Time	25 MHz	20 MHz	16 MHz	12 MHz	10 MHz	8 MHz	6 MHz	4 MHz	2 MHz	Unit
0	0	0	8192 states	0.32	0.41	0.51	0.68	0.8	1.0	1.3	2.0	4.1	ms
		1	16384 states	0.65	0.82	1.0	1.3	1.6	2.0	2.7	4.1	8.2	
	1	0	32768 states	1.3	1.6	2.0	2.7	3.3	4.1	5.5	8.2	16.4	
		1	65536 states	2.6	3.3	4.1	5.5	6.6	8.2	10.9	16.4	32.8	
1	0	0	131072 states	5.2	6.6	8.2	10.9	13.1	16.4	21.8	32.8	65.5	
		1	262144 states	10.4	13.1	16.4	21.8	26.2	32.8	43.6	65.6	131.2	
1	1	0	Reserved	—	—	—	—	—	—	—	—	—	
		1	16 states	0.6	0.8	1.0	1.3	1.6	2.0	2.7	4.0	8.0	

: Recommended time setting

Using an External Clock: Any value can be set. Normally, use of the minimum time is recommended*.

Note: * The 16-state standby time cannot be used in the F-ZTAT versions; a standby time of 8192 states or longer should be used.

19.6.4 Software Standby Mode Application Example

Figure 19.2 shows an example in which a transition is made to software standby mode at the falling edge on the NMI pin, and software standby mode is cleared at the rising edge on the NMI pin.

In this example, an NMI interrupt is accepted with the NMIEG bit in SYSCR cleared to 0 (falling edge specification), then the NMIEG bit is set to 1 (rising edge specification), the SSBY bit is set to 1, and a SLEEP instruction is executed, causing a transition to software standby mode.

Software standby mode is then cleared at the rising edge on the NMI pin.

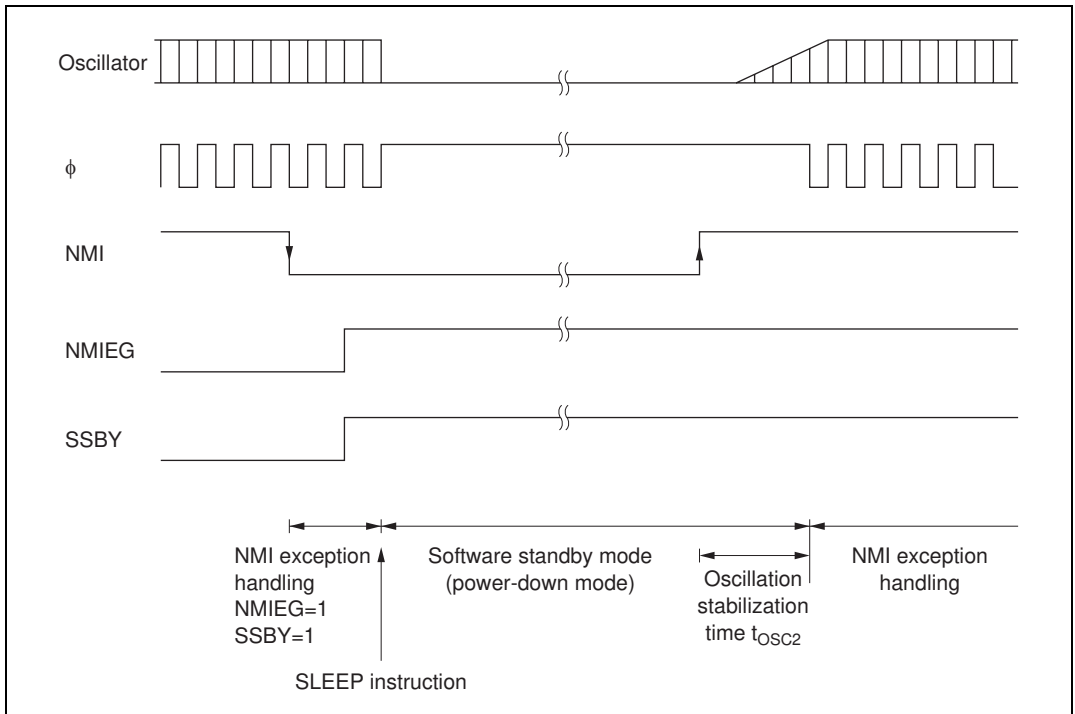

Figure 19.2 Software Standby Mode Application Example

19.6.5 Usage Notes

I/O Port Status: In software standby mode, I/O port states are retained. If the OPE bit is set to 1, the address bus and bus control signal output is also retained. Therefore, there is no reduction in current dissipation for the output current when a high-level signal is output.

Current Dissipation during Oscillation Stabilization Wait Period: Current dissipation increases during the oscillation stabilization wait period.

19.7 Hardware Standby Mode

19.7.1 Hardware Standby Mode

When the $\overline{\text{STBY}}$ pin is driven low, a transition is made to hardware standby mode from any mode.

In hardware standby mode, all functions enter the reset state and stop operation, resulting in a significant reduction in power dissipation. As long as the prescribed voltage is supplied, on-chip RAM data is retained. I/O ports are set to the high-impedance state.

In order to retain on-chip RAM data, the RAME bit in SYSCR should be cleared to 0 before driving the $\overline{\text{STBY}}$ pin low.

Do not change the state of the mode pins (MD2 to MD0) while the chip is in hardware standby mode.

Hardware standby mode is cleared by means of the $\overline{\text{STBY}}$ pin and the $\overline{\text{RES}}$ pin. When the $\overline{\text{STBY}}$ pin is driven high while the $\overline{\text{RES}}$ pin is low, the reset state is set and clock oscillation is started. Ensure that the $\overline{\text{RES}}$ pin is held low until the clock oscillator stabilizes (at least 8 ms—the oscillation stabilization time—when using a crystal oscillator). When the $\overline{\text{RES}}$ pin is subsequently driven high, a transition is made to the program execution state via the reset exception handling state.

19.7.2 Hardware Standby Mode Timing

Figure 19.3 shows an example of hardware standby mode timing.

When the $\overline{\text{STBY}}$ pin is driven low after the $\overline{\text{RES}}$ pin has been driven low, a transition is made to hardware standby mode. Hardware standby mode is cleared by driving the $\overline{\text{STBY}}$ pin high, waiting for the oscillation stabilization time, then changing the $\overline{\text{RES}}$ pin from low to high.

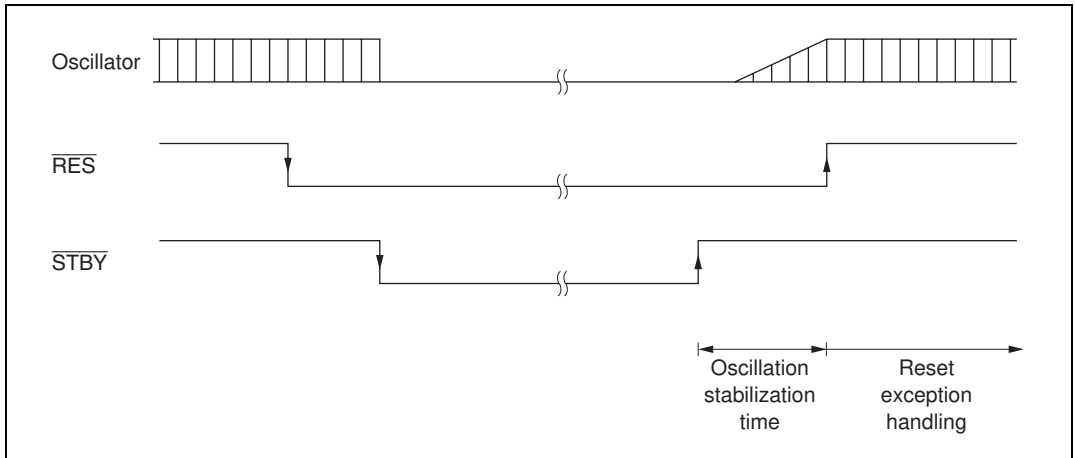

Figure 19.3 Hardware Standby Mode Timing

19.8 ϕ Clock Output Disabling Function

Output of the ϕ clock can be controlled by means of the PSTOP bit in SCKCR, and DDR for the corresponding port. When the PSTOP bit is set to 1, the ϕ clock stops at the end of the bus cycle, and ϕ output goes high. ϕ clock output is enabled when the PSTOP bit is cleared to 0. When DDR for the corresponding port is cleared to 0, ϕ clock output is disabled and input port mode is set. Table 19.5 shows the state of the ϕ pin in each processing state.

Table 19.5 ϕ Pin State in Each Processing State

DDR	0	1	1
PSTOP	—	0	1
Hardware standby mode	High impedance	High impedance	High impedance
Software standby mode	High impedance	Fixed high	Fixed high
Sleep mode	High impedance	ϕ output	Fixed high
Normal operating state	High impedance	ϕ output	Fixed high

Section 20 Electrical Characteristics

20.1 Electrical Characteristics of Mask ROM Version (H8S/2319, H8S/2318, H8S/2317S, H8S/2316S, H8S/2315, H8S/2314) and ROMless Version (H8S/2312S)

20.1.1 Absolute Maximum Ratings

Table 20.1 lists the absolute maximum ratings.

Table 20.1 Absolute Maximum Ratings

Item	Symbol	Value	Unit
Power supply voltage	V_{CC}	-0.3 to +4.3	V
Input voltage (except port 4)	V_{in}	-0.3 to $V_{CC} + 0.3$	V
Input voltage (port 4)	V_{in}	-0.3 to $AV_{CC} + 0.3$	V
Reference power supply voltage	V_{ref}	-0.3 to $AV_{CC} + 0.3$	V
Analog power supply voltage	AV_{CC}	-0.3 to +4.3	V
Analog input voltage	V_{AN}	-0.3 to $AV_{CC} + 0.3$	V
Operating temperature	T_{opr}	Regular specifications: -20 to +75	°C
		Wide-range specifications: -40 to +85	°C
Storage temperature	T_{stg}	-55 to +125	°C

Caution: Permanent damage to the chip may result if absolute maximum ratings are exceeded.

20.1.2 DC Characteristics

Table 20.2 DC Characteristics

Conditions: $V_{CC} = 2.7 \text{ V to } 3.6 \text{ V}$, $AV_{CC} = 2.7 \text{ V to } 3.6 \text{ V}$, $V_{ref} = 2.7 \text{ V to } AV_{CC}$, $V_{SS} = AV_{SS} = 0 \text{ V}^{*1}$, $T_a = -20^\circ\text{C to } +75^\circ\text{C}$ (regular specifications), $T_a = -40^\circ\text{C to } +85^\circ\text{C}$ (wide-range specifications)

Item	Symbol	Min	Typ	Max	Unit	Test Conditions	
Schmitt trigger input voltage	Ports 1, 2, $\overline{\text{IRQ0}}$ to $\overline{\text{IRQ7}}$	V_T^-	$V_{CC} \times 0.2$	—	—	V	
		V_T^+	—	—	$V_{CC} \times 0.7$	V	
		$V_T^+ - V_T^-$	$V_{CC} \times 0.07$	—	—	V	
Input high voltage	$\overline{\text{RES}}$, $\overline{\text{STBY}}$, NMI, MD2 to MD0	V_{IH}	$V_{CC} \times 0.9$	—	$V_{CC} + 0.3$	V	
	EXTAL		$V_{CC} \times 0.7$	—	$V_{CC} + 0.3$	V	
	Ports 3, A to G		2.2	—	$V_{CC} + 0.3$	V	
	Port 4		2.2	—	$AV_{CC} + 0.3$	V	
Input low voltage	$\overline{\text{RES}}$, $\overline{\text{STBY}}$, MD2 to MD0	V_{IL}	-0.3	—	$V_{CC} \times 0.1$	V	
	NMI, EXTAL, ports 3, 4, A to G		-0.3	—	$V_{CC} \times 0.2$	V	
Output high voltage	All output pins	V_{OH}	$V_{CC} - 0.5$	—	—	V	$I_{OH} = -200 \mu\text{A}$
			$V_{CC} - 1.0$	—	—	V	$I_{OH} = -1 \text{ mA}$
Output low voltage	All output pins	V_{OL}	—	—	0.4	V	$I_{OL} = 1.6 \text{ mA}$
Input leakage current	$\overline{\text{RES}}$	$ I_{in} $	—	—	10.0	μA	$V_{in} = 0.5 \text{ V to } V_{CC} - 0.5 \text{ V}$
	$\overline{\text{STBY}}$, NMI, MD2 to MD0		—	—	1.0	μA	
	Port 4		—	—	1.0	μA	$V_{in} = 0.5 \text{ V to } AV_{CC} - 0.5 \text{ V}$
Three-state leakage current (off state)	Ports 1, 2, 3, A to G	$ I_{TSI} $	—	—	1.0	μA	$V_{in} = 0.5 \text{ V to } V_{CC} - 0.5 \text{ V}$

Item		Symbol	Min	Typ	Max	Unit	Test Conditions
Input pull-up MOS current	Ports A to E	$-I_p$	10	—	300	μA	$V_{in} = 0\text{ V}$
Input capacitance	RES	C_{in}	—	—	30	pF	$V_{in} = 0\text{ V}$
	NMI		—	—	30	pF	$f = 1\text{ MHz}$
	All input pins except RES and NMI		—	—	15	pF	$T_a = 25^\circ\text{C}$
Current dissipation *2	Normal operation	I_{CC}^{*4}	—	35 (3.0 V)	80	mA	$f = 20\text{ MHz}$
			—	50 (3.3 V)	100	mA	$f = 25\text{ MHz}$
	Sleep mode		—	25 (3.0 V)	64	mA	$f = 20\text{ MHz}$
			—	35 (3.3 V)	80	mA	$f = 25\text{ MHz}$
	Standby mode *3		—	0.01	10	μA	$T_a \leq 50^\circ\text{C}$
			—	—	80	μA	$50^\circ\text{C} < T_a$
Analog power supply voltage	During A/D and D/A conversion	AI_{CC}	—	0.2 (3.0 V)	2.0	mA	
	Idle		—	0.01	5.0	μA	
Reference power supply voltage	During A/D and D/A conversion	AI_{CC}	—	1.4 (3.0 V)	3.0	mA	
	Idle		—	0.01	5.0	μA	
RAM standby voltage		V_{RAM}	2.0	—	—	V	

- Notes: 1. **If the A/D and D/A converters are not used, do not leave the AV_{CC} , V_{ref} , and AV_{SS} pins open.** Connect the AV_{CC} and V_{ref} pins to V_{CC} , and the AV_{SS} pin to V_{SS} .
2. Current dissipation values are for $V_{IH\ min} = V_{CC} - 0.2\text{ V}$ and $V_{IL\ max} = 0.2\text{ V}$ with all output pins unloaded and all MOS input pull-ups in the off state.
3. The values are for $V_{RAM} \leq V_{CC} < 2.7\text{ V}$, $V_{IH\ min} = V_{CC} \times 0.9$, and $V_{IL\ max} = 0.3\text{ V}$.
4. I_{CC} depends on V_{CC} and f as follows:
 $I_{CC\ max} = 1.0\text{ (mA)} + 1.10\text{ (mA/(MHz} \times \text{V))} \times V_{CC} \times f$ (normal operation)
 $I_{CC\ max} = 1.0\text{ (mA)} + 0.88\text{ (mA/(MHz} \times \text{V))} \times V_{CC} \times f$ (sleep mode)

Table 20.3 Permissible Output Currents

Conditions: $V_{CC} = 2.7\text{ V to }3.6\text{ V}$, $AV_{CC} = 2.7\text{ V to }3.6\text{ V}$, $V_{ref} = 2.7\text{ V to }AV_{CC}$, $V_{SS} = AV_{SS} = 0\text{ V}$, $T_a = -20^\circ\text{C to }+75^\circ\text{C}$ (regular specifications), $T_a = -40^\circ\text{C to }+85^\circ\text{C}$ (wide-range specifications)

Item		Symbol	Min	Typ	Max	Unit
Permissible output low current (per pin)	All output pins	I_{OL}	—	—	2.0	mA
Permissible output low current (total)	Total of all output pins	ΣI_{OL}	—	—	80	mA
Permissible output high current (per pin)	All output pins	$-I_{OH}$	—	—	2.0	mA
Permissible output high current (total)	Total of all output pins	$\Sigma -I_{OH}$	—	—	40	mA

Note: To protect chip reliability, do not exceed the output current values in table 20.3.

20.1.3 AC Characteristics

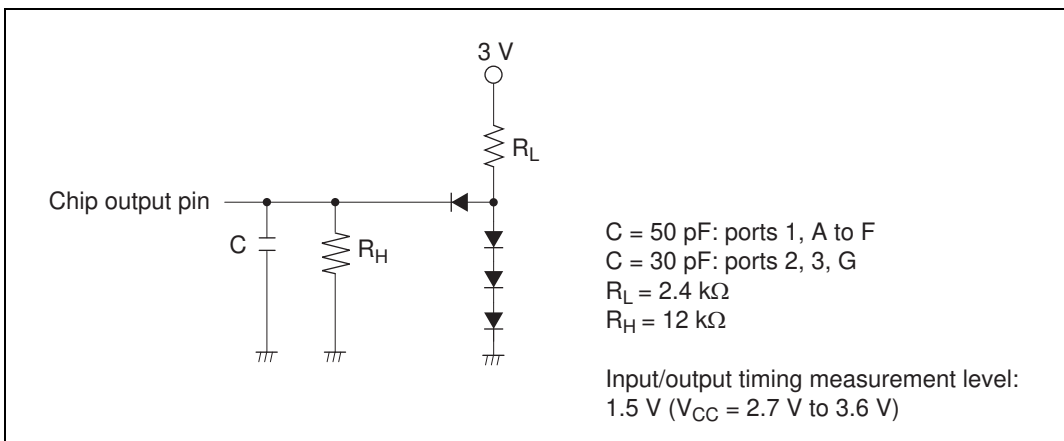

Figure 20.1 Output Load Circuit

(1) Clock Timing**Table 20.4 Clock Timing**

Condition A: $V_{CC} = 2.7\text{ V to }3.6\text{ V}$, $AV_{CC} = 2.7\text{ V to }3.6\text{ V}$, $V_{ref} = 2.7\text{ V to }AV_{CC}$, $V_{SS} = AV_{SS} = 0\text{ V}$, $\phi = 2\text{ MHz to }20\text{ MHz}$, $T_a = -20^\circ\text{C to }75^\circ\text{C}$ (regular specifications),
 $T_a = -40^\circ\text{C to }85^\circ\text{C}$ (wide-range specifications)

Condition B: $V_{CC} = 3.0\text{ V to }3.6\text{ V}$, $AV_{CC} = 3.0\text{ V to }3.6\text{ V}$, $V_{ref} = 3.0\text{ V to }AV_{CC}$, $V_{SS} = AV_{SS} = 0\text{ V}$, $\phi = 2\text{ MHz to }25\text{ MHz}$, $T_a = -20^\circ\text{C to }75^\circ\text{C}$ (regular specifications),
 $T_a = -40^\circ\text{C to }85^\circ\text{C}$ (wide-range specifications)

Item	Symbol	Condition A		Condition B		Unit	Test Conditions
		Min	Max	Min	Max		
Clock cycle time	t_{cyc}	50	500	40	500	ns	Figure 20.2
Clock pulse high width	t_{cH}	20	—	15	—	ns	
Clock pulse low width	t_{cL}	20	—	15	—	ns	
Clock rise time	t_{cR}	—	5	—	5	ns	
Clock fall time	t_{cF}	—	5	—	5	ns	
Reset oscillation stabilization time (crystal)	t_{OSC1}	10	—	10	—	ms	Figure 20.3
Software standby oscillation stabilization time (crystal)	t_{OSC2}	10	—	10	—	ms	
External clock output stabilization delay time	t_{DEXT}	500	—	500	—	μs	Figure 20.3

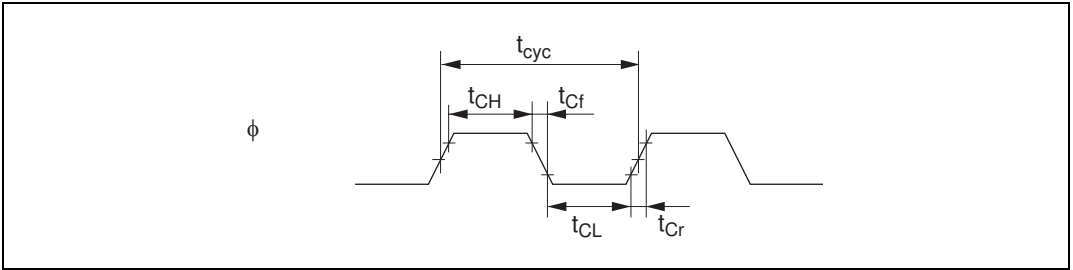

Figure 20.2 System Clock Timing

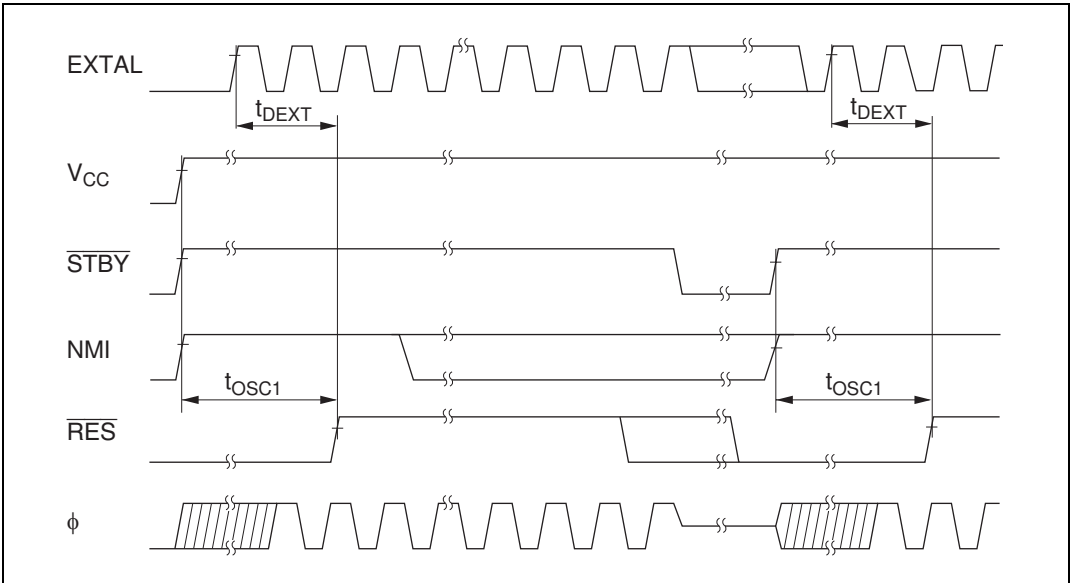

Figure 20.3 Oscillation Stabilization Timing

(2) Control Signal Timing**Table 20.5 Control Signal Timing**

Condition A: $V_{CC} = 2.7\text{ V to }3.6\text{ V}$, $AV_{CC} = 2.7\text{ V to }3.6\text{ V}$, $V_{ref} = 2.7\text{ V to }AV_{CC}$, $V_{SS} = AV_{SS} = 0\text{ V}$, $\phi = 2\text{ MHz to }20\text{ MHz}$, $T_a = -20^\circ\text{C to }75^\circ\text{C}$ (regular specifications),
 $T_a = -40^\circ\text{C to }85^\circ\text{C}$ (wide-range specifications)

Condition B: $V_{CC} = 3.0\text{ V to }3.6\text{ V}$, $AV_{CC} = 3.0\text{ V to }3.6\text{ V}$, $V_{ref} = 3.0\text{ V to }AV_{CC}$, $V_{SS} = AV_{SS} = 0\text{ V}$, $\phi = 2\text{ MHz to }25\text{ MHz}$, $T_a = -20^\circ\text{C to }75^\circ\text{C}$ (regular specifications),
 $T_a = -40^\circ\text{C to }85^\circ\text{C}$ (wide-range specifications)

Item	Symbol	Condition A		Condition B		Unit	Test Conditions
		Min	Max	Min	Max		
\overline{RES} setup time	t_{RESS}	200	—	200	—	ns	Figure 20.4
\overline{RES} pulse width	t_{RESW}	20	—	20	—	t_{cyc}	
NMI setup time	t_{NMIS}	150	—	150	—	ns	Figure 20.5
NMI hold time	t_{NMIH}	10	—	10	—		
NMI pulse width (in recovery from software standby mode)	t_{NMIW}	200	—	200	—		
\overline{IRQ} setup time	t_{IRQS}	150	—	150	—	ns	
\overline{IRQ} hold time	t_{IRQH}	10	—	10	—		
\overline{IRQ} pulse width (in recovery from software standby mode)	t_{IRQW}	200	—	200	—		

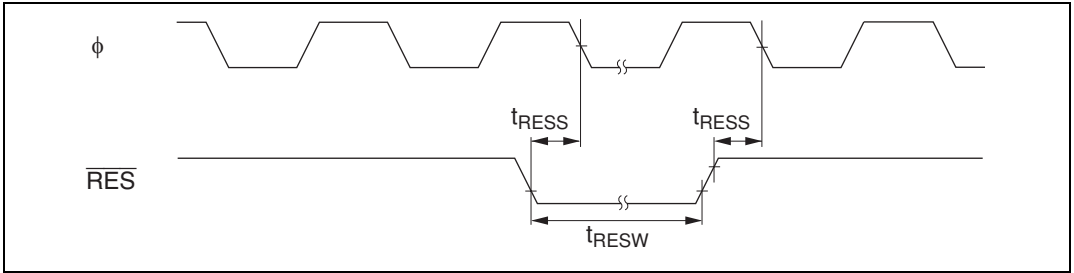

Figure 20.4 Reset Input Timing

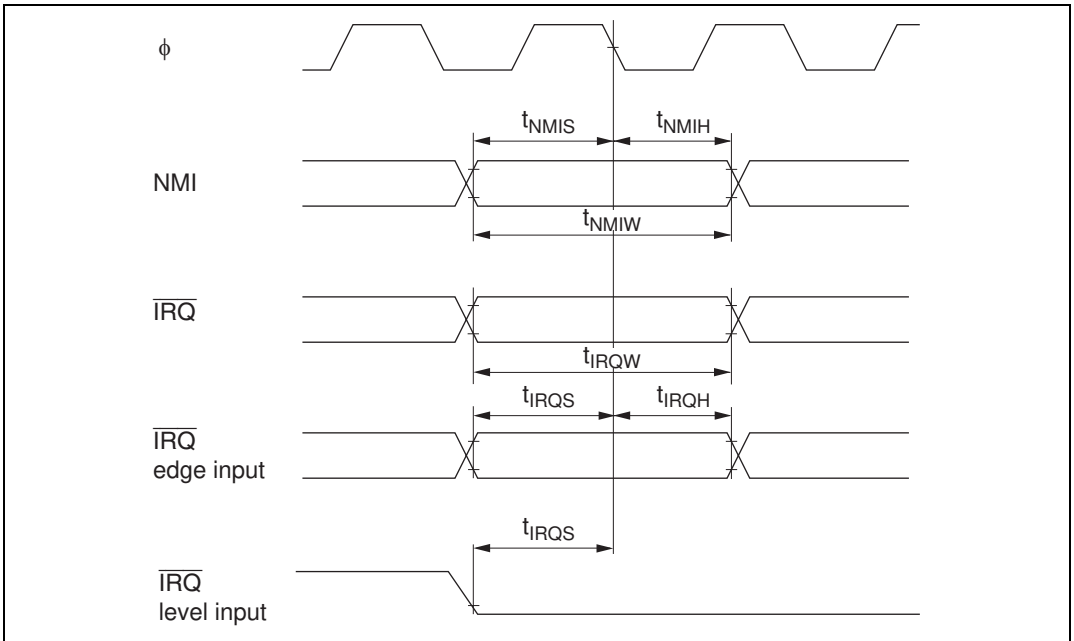

Figure 20.5 Interrupt Input Timing

(3) Bus Timing**Table 20.6 Bus Timing**

Condition A: $V_{CC} = 2.7\text{ V to }3.6\text{ V}$, $AV_{CC} = 2.7\text{ V to }3.6\text{ V}$, $V_{ref} = 2.7\text{ V to }AV_{CC}$, $V_{SS} = AV_{SS} = 0\text{ V}$, $\phi = 2\text{ MHz to }20\text{ MHz}$, $T_a = -20^\circ\text{C to }75^\circ\text{C}$ (regular specifications),
 $T_a = -40^\circ\text{C to }85^\circ\text{C}$ (wide-range specifications)

Condition B: $V_{CC} = 3.0\text{ V to }3.6\text{ V}$, $AV_{CC} = 3.0\text{ V to }3.6\text{ V}$, $V_{ref} = 3.0\text{ V to }AV_{CC}$, $V_{SS} = AV_{SS} = 0\text{ V}$, $\phi = 2\text{ MHz to }25\text{ MHz}$, $T_a = -20^\circ\text{C to }75^\circ\text{C}$ (regular specifications),
 $T_a = -40^\circ\text{C to }85^\circ\text{C}$ (wide-range specifications)

Item	Symbol	Condition A		Condition B		Unit	Test Conditions
		Min	Max	Min	Max		
Address delay time	t_{AD}	—	20	—	20	ns	Figures 20.6 to 20.10
Address setup time	t_{AS}	$0.5 \times t_{cyc} - 15$	—	$0.5 \times t_{cyc} - 15$	—	ns	
Address hold time	t_{AH}	$0.5 \times t_{cyc} - 10$	—	$0.5 \times t_{cyc} - 8$	—	ns	
\overline{CS} delay time 1	t_{CSD1}	—	20	—	15	ns	
\overline{AS} delay time	t_{ASD}	—	20	—	15	ns	
\overline{RD} delay time 1	t_{RSD1}	—	20	—	15	ns	
\overline{RD} delay time 2	t_{RSD2}	—	20	—	15	ns	
Read data setup time	t_{RDS}	15	—	15	—	ns	
Read data hold time	t_{RDH}	0	—	0	—	ns	
Read data access time 1	t_{ACC1}	—	$1.0 \times t_{cyc} - 25$	—	$1.0 \times t_{cyc} - 20$	ns	
Read data access time 2	t_{ACC2}	—	$1.5 \times t_{cyc} - 25$	—	$1.5 \times t_{cyc} - 20$	ns	
Read data access time 3	t_{ACC3}	—	$2.0 \times t_{cyc} - 25$	—	$2.0 \times t_{cyc} - 20$	ns	
Read data access time 4	t_{ACC4}	—	$2.5 \times t_{cyc} - 25$	—	$2.5 \times t_{cyc} - 20$	ns	
Read data access time 5	t_{ACC5}	—	$3.0 \times t_{cyc} - 25$	—	$3.0 \times t_{cyc} - 20$	ns	

Item	Symbol	Condition A		Condition B		Unit	Test Conditions
		Min	Max	Min	Max		
WR delay time 1	t_{WRD1}	—	20	—	15	ns	Figures 20.6 to 20.10
WR delay time 2	t_{WRD2}	—	20	—	15	ns	
WR pulse width 1	t_{WSW1}	$1.0 \times$ $t_{cyc} - 20$	—	$1.0 \times$ $t_{cyc} - 15$	—	ns	
WR pulse width 2	t_{WSW2}	$1.5 \times$ $t_{cyc} - 20$	—	$1.5 \times$ $t_{cyc} - 15$	—	ns	
Write data delay time	t_{WDD}	—	30	—	20	ns	
Write data setup time	t_{WDS}	$0.5 \times$ $t_{cyc} - 20$	—	$0.5 \times$ $t_{cyc} - 15$	—	ns	
Write data hold time	t_{WDH}	$0.5 \times$ $t_{cyc} - 10$	—	$0.5 \times$ $t_{cyc} - 8$	—	ns	
WAIT setup time	t_{WTS}	30	—	25	—	ns	Figure 20.8
WAIT hold time	t_{WTH}	5	—	5	—	ns	
BREQ setup time	t_{BRQS}	30	—	30	—	ns	Figure 20.11
BACK delay time	t_{BACD}	—	15	—	15	ns	
Bus floating time	t_{BZD}	—	50	—	40	ns	
BREQO delay time	t_{BRQOD}	—	30	—	25	ns	Figure 20.12

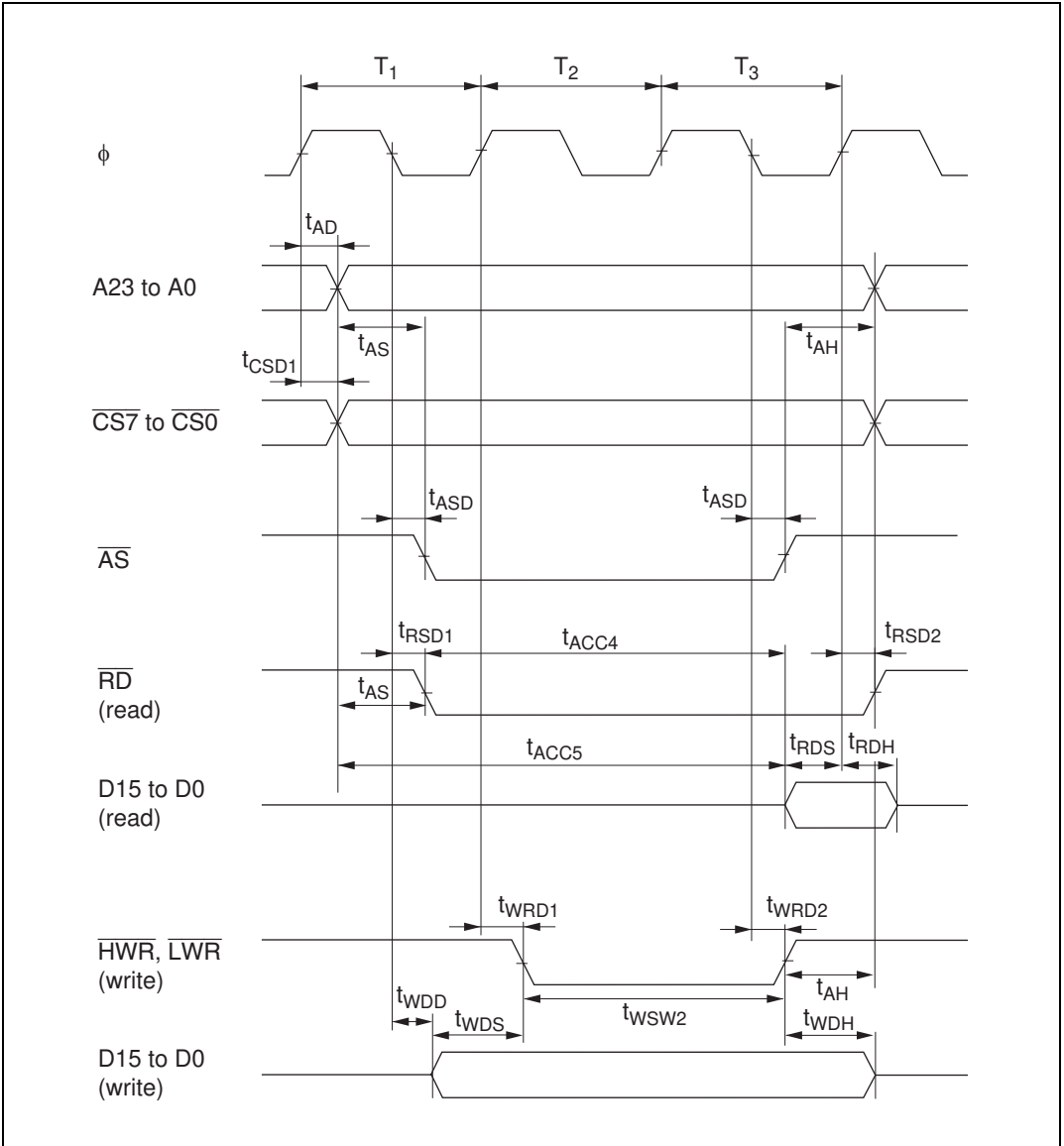

Figure 20.7 Basic Bus Timing (3-State Access)

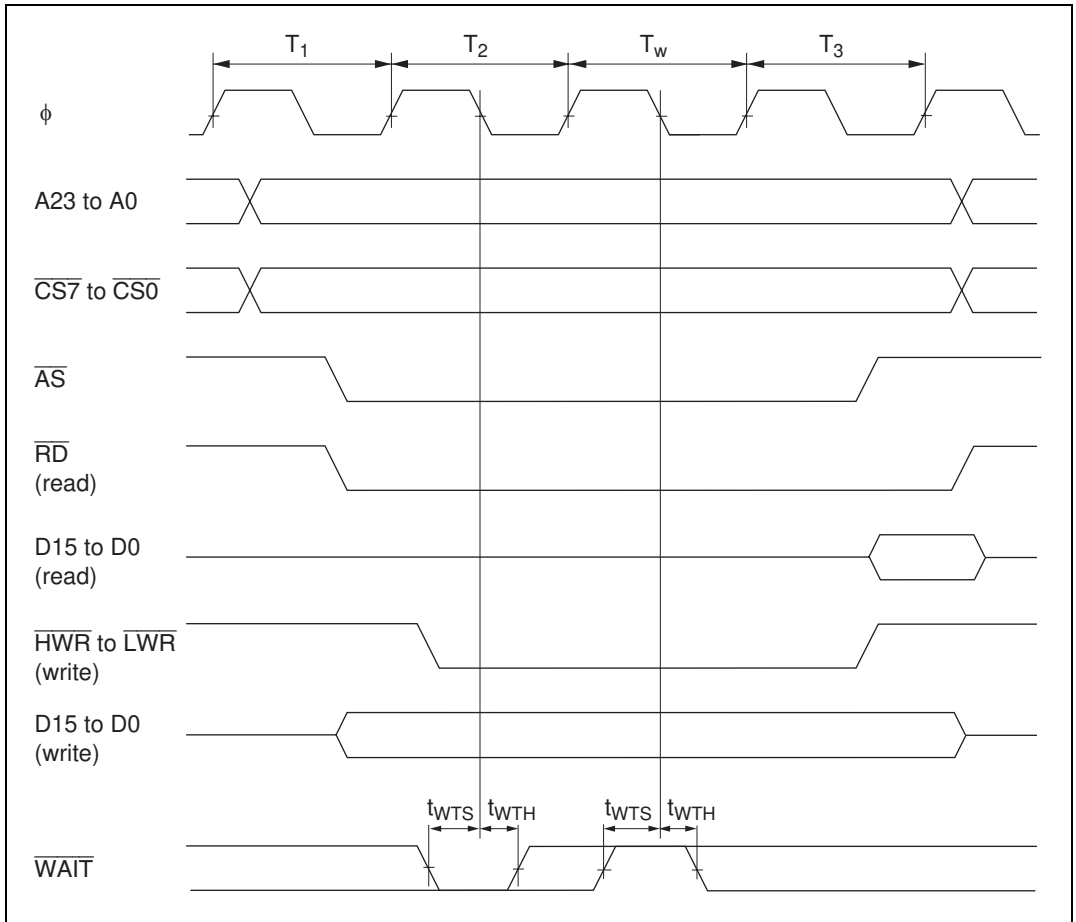

Figure 20.8 Basic Bus Timing (3-State Access, 1 Wait)

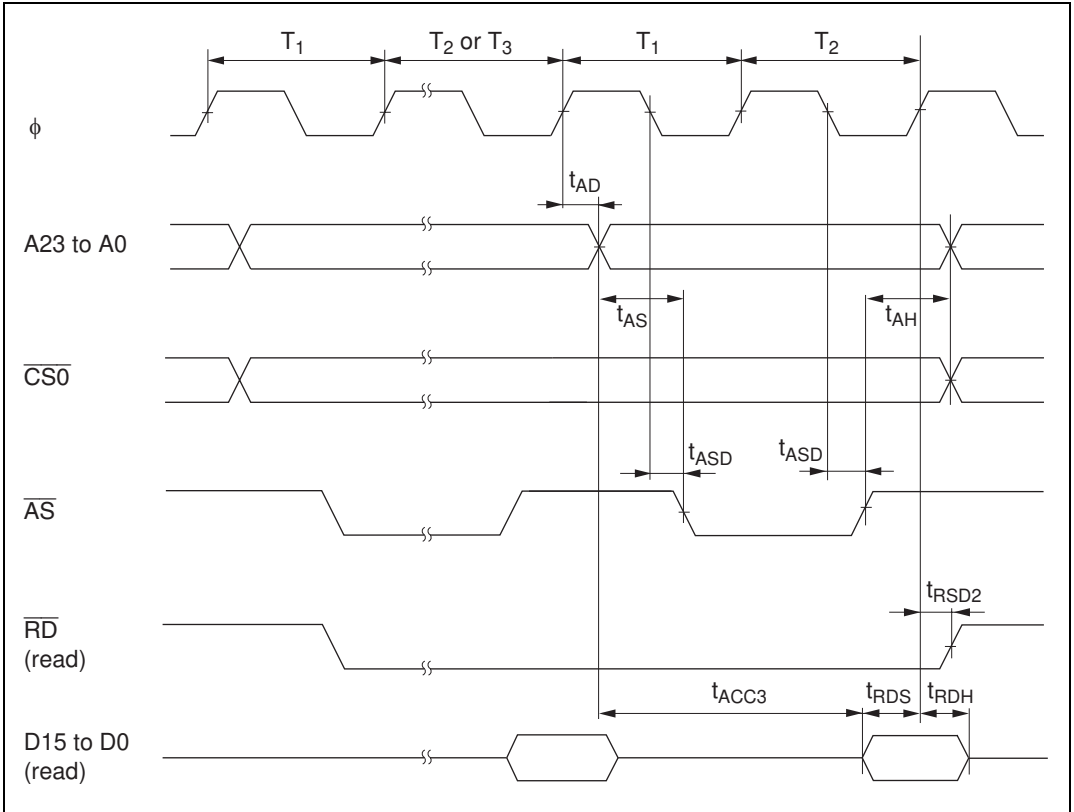

Figure 20.9 Burst ROM Access Timing (2-State Access)

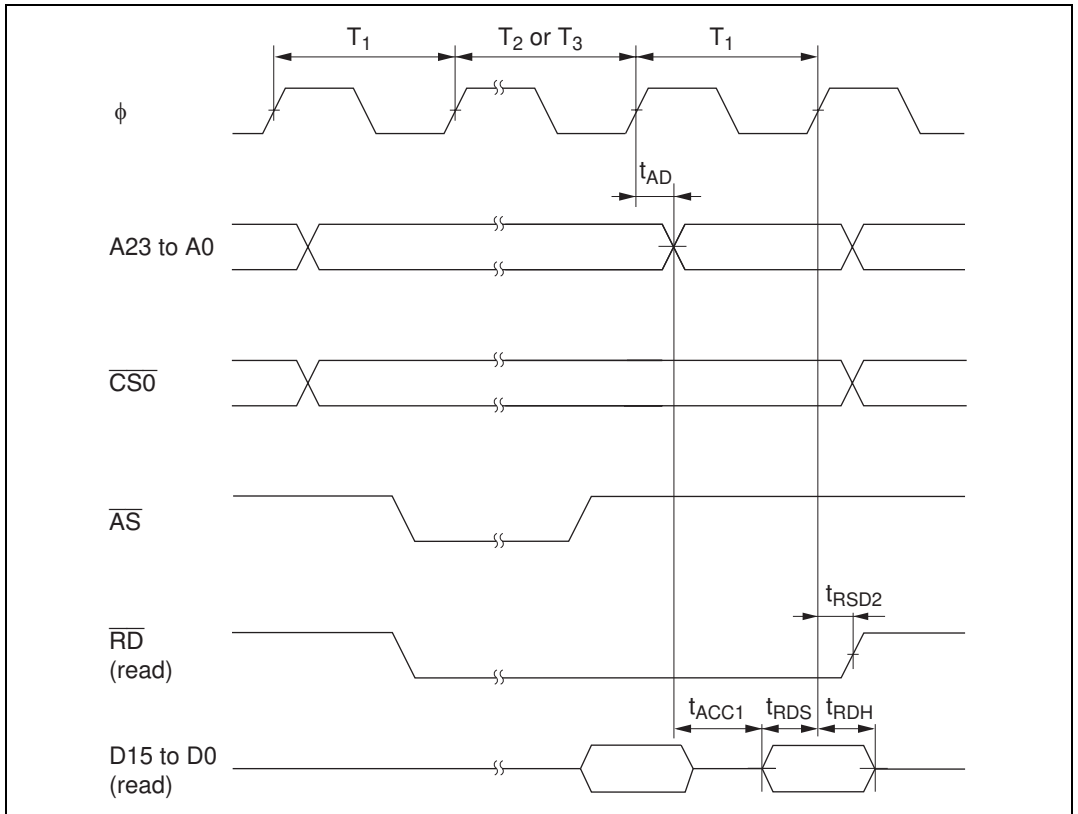

Figure 20.10 Burst ROM Access Timing (1-State Access)

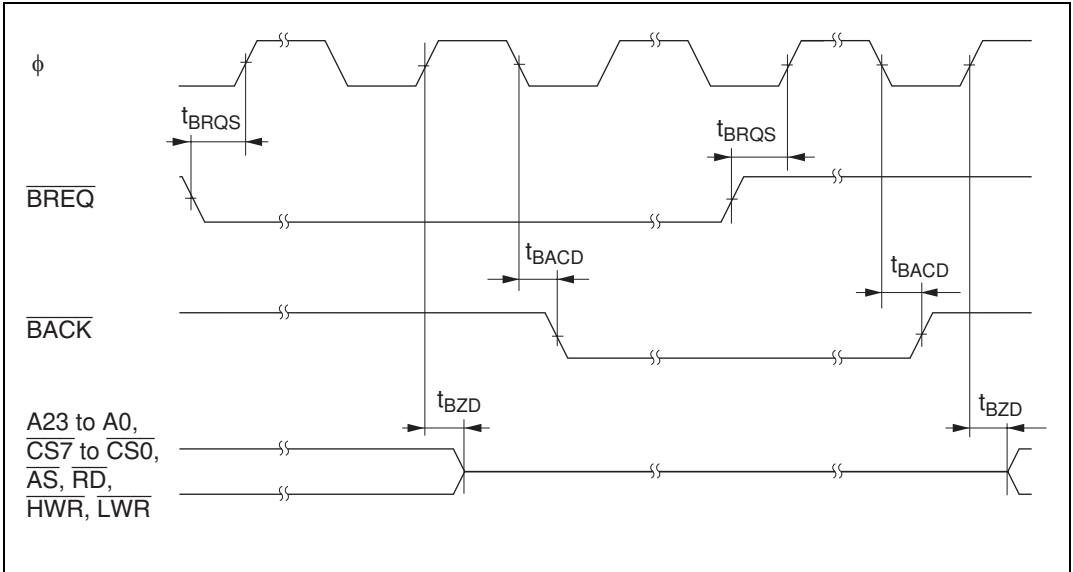

Figure 20.11 External Bus Release Timing

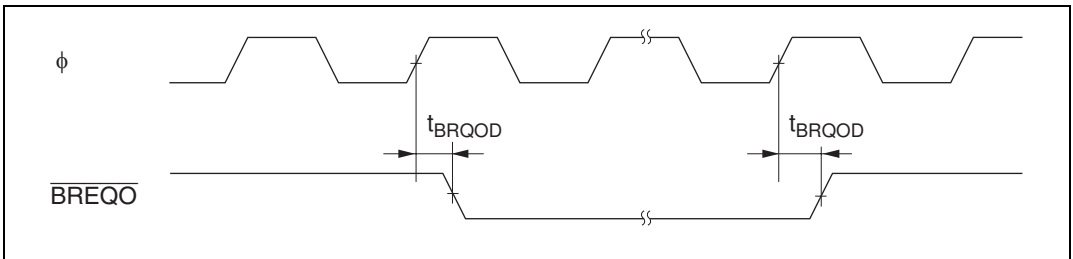

Figure 20.12 External Bus Request Output Timing

(4) Timing of On-Chip Supporting Modules**Table 20.7 Timing of On-Chip Supporting Modules**

Condition A: $V_{CC} = 2.7\text{ V to }3.6\text{ V}$, $AV_{CC} = 2.7\text{ V to }3.6\text{ V}$, $V_{ref} = 2.7\text{ V to }AV_{CC}$, $V_{SS} = AV_{SS} = 0\text{ V}$, $\phi = 2\text{ MHz to }20\text{ MHz}$, $T_a = -20^\circ\text{C to }75^\circ\text{C}$ (regular specifications),
 $T_a = -40^\circ\text{C to }85^\circ\text{C}$ (wide-range specifications)

Condition B: $V_{CC} = 3.0\text{ V to }3.6\text{ V}$, $AV_{CC} = 3.0\text{ V to }3.6\text{ V}$, $V_{ref} = 3.0\text{ V to }AV_{CC}$, $V_{SS} = AV_{SS} = 0\text{ V}$, $\phi = 2\text{ MHz to }25\text{ MHz}$, $T_a = -20^\circ\text{C to }75^\circ\text{C}$ (regular specifications),
 $T_a = -40^\circ\text{C to }85^\circ\text{C}$ (wide-range specifications)

Item	Symbol	Condition A		Condition B		Unit	Test Conditions		
		Min	Max	Min	Max				
I/O ports	Output data delay time	t_{PWD}	—	50	—	40	ns	Figure 20.13	
	Input data setup time	t_{PRS}	30	—	25	—	ns		
	Input data hold time	t_{PRH}	30	—	25	—	ns		
TPU	Timer output delay time	t_{TOCD}	—	50	—	40	ns	Figure 20.14	
	Timer input setup time	t_{TICS}	30	—	25	—	ns		
	Timer clock input setup time	t_{TCKS}	30	—	25	—	ns	Figure 20.15	
	Timer clock pulse width	Single-edge specification	t_{TCKWH}	1.5	—	1.5	—		t_{cyc}
		Both-edge specification	t_{TCKWL}	2.5	—	2.5	—		t_{cyc}
8-bit timer	Timer output delay time	t_{TMOD}	—	50	—	40	ns	Figure 20.16	
	Timer reset input setup time	t_{TMRS}	30	—	25	—	ns		Figure 20.18
	Timer clock input setup time	t_{TMCS}	30	—	25	—	ns	Figure 20.17	
	Timer clock pulse width	Single-edge specification	t_{TMCWH}	1.5	—	1.5	—		t_{cyc}
		Both-edge specification	t_{TMCWL}	2.5	—	2.5	—		t_{cyc}
WDT	Overflow output delay time	t_{WOVD}	—	50	—	40	ns	Figure 20.19	

Item	Symbol	Condition A		Condition B		Unit	Test Conditions		
		Min	Max	Min	Max				
SCI	Input clock cycle	Asynchronous	$t_{S_{cyc}}$	4	—	4	—	t_{cyc}	Figure 20.20
		Synchronous		6	—	6	—		
	Input clock pulse width	$t_{S_{CKW}}$	0.4	0.6	0.4	0.6	$t_{S_{cyc}}$		
	Input clock rise time	$t_{S_{CKr}}$	—	1.5	—	1.5	t_{cyc}		
	Input clock fall time	$t_{S_{CKf}}$	—	1.5	—	1.5	t_{cyc}		
	Transmit data delay time	t_{TXD}	—	50	—	40	ns	Figure 20.21	
	Receive data setup time (synchronous)	t_{RXS}	50	—	40	—	ns		
	Receive data hold time (synchronous)	t_{RXH}	50	—	40	—	ns		
A/D converter	Trigger input setup time	t_{TRGS}	30	—	30	—	ns	Figure 20.22	

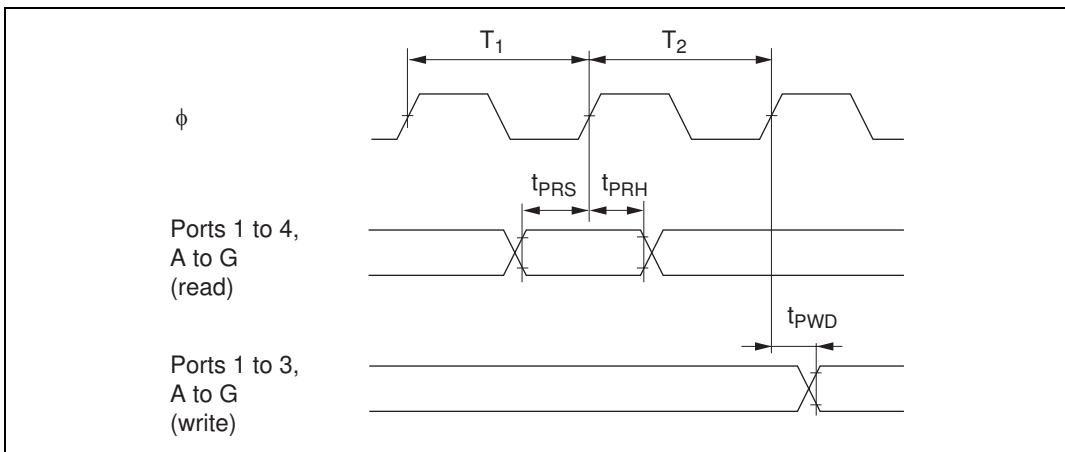

Figure 20.13 I/O Port Input/Output Timing

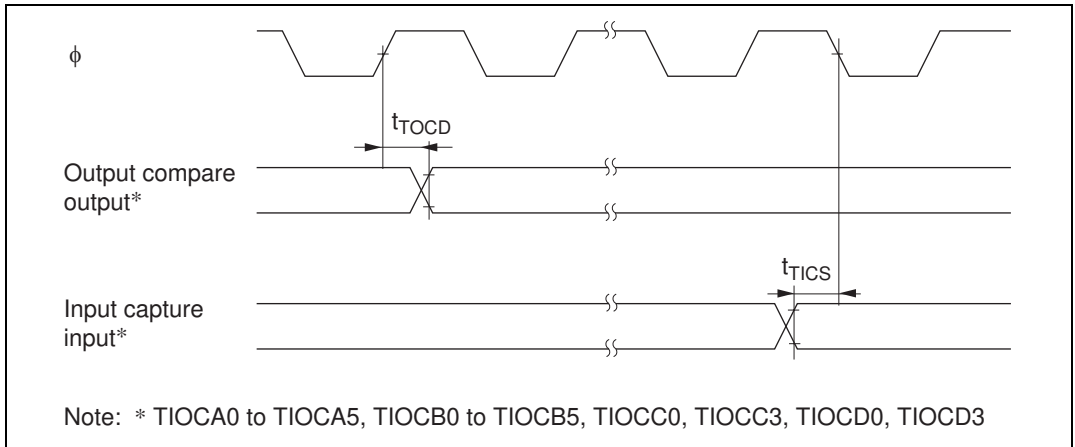

Figure 20.14 TPU Input/Output Timing

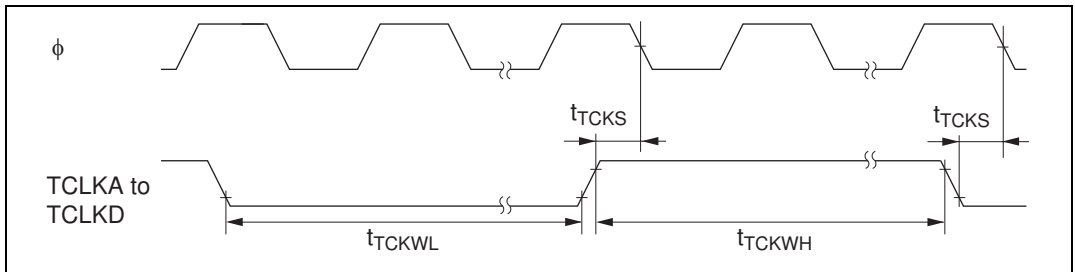

Figure 20.15 TPU Clock Input Timing

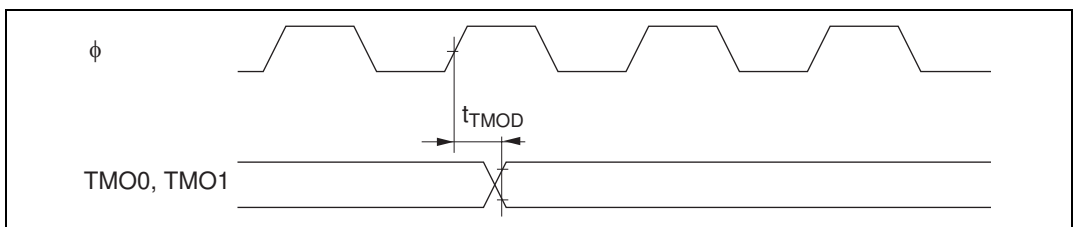

Figure 20.16 8-Bit Timer Output Timing

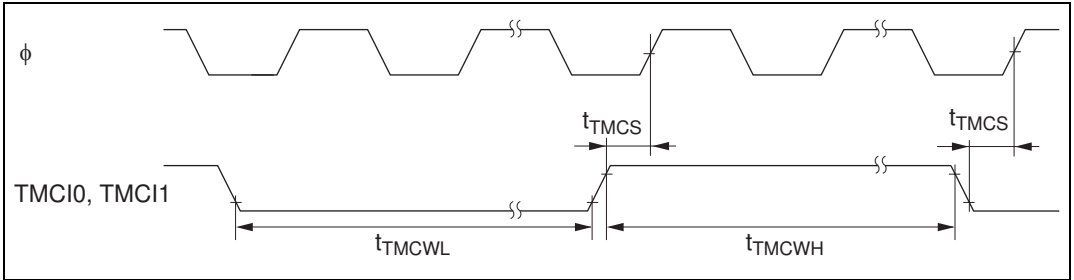

Figure 20.17 8-Bit Timer Clock Input Timing

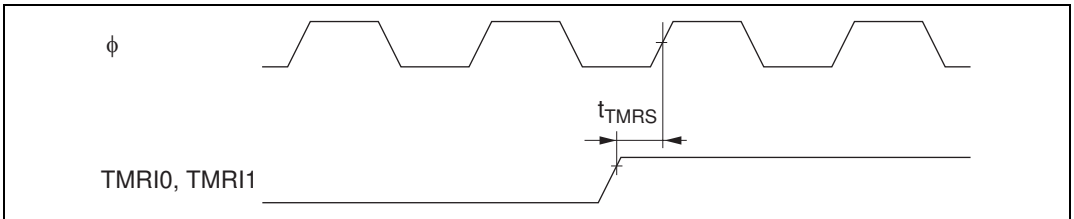

Figure 20.18 8-Bit Timer Reset Input Timing

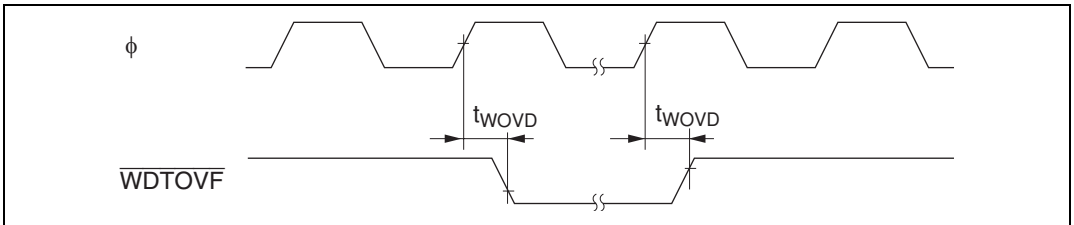

Figure 20.19 WDT Output Timing

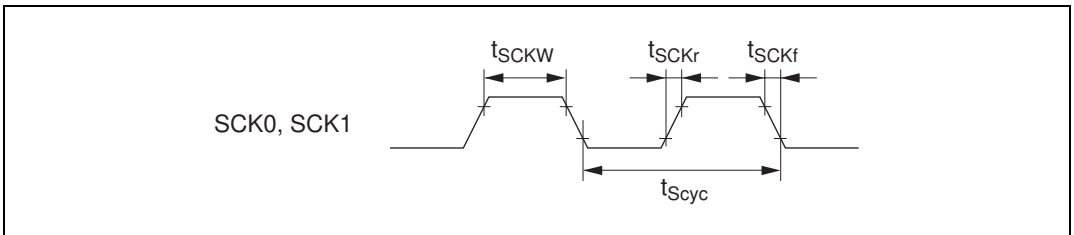

Figure 20.20 SCK Clock Input Timing

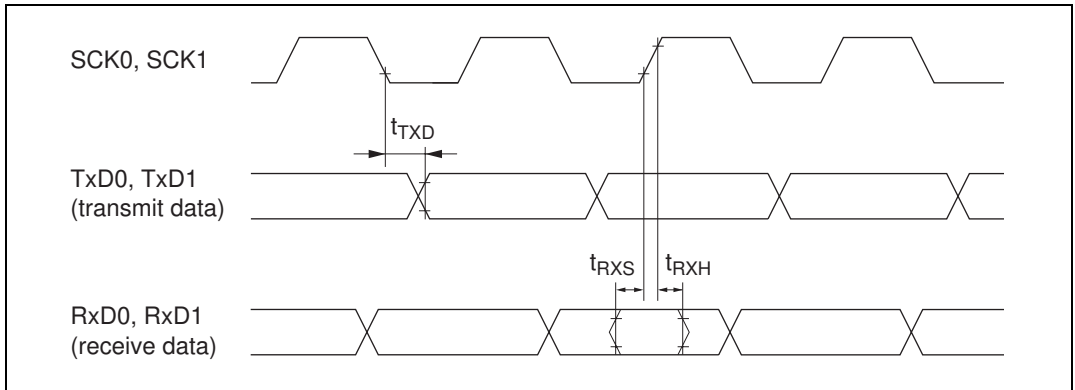

Figure 20.21 SCI Input/Output Timing (Synchronous Mode)

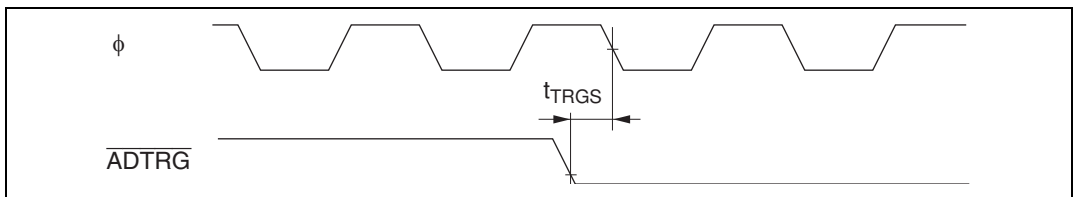

Figure 20.22 A/D Converter External Trigger Input Timing

20.1.4 A/D Conversion Characteristics

Table 20.8 A/D Conversion Characteristics

Condition A: $V_{CC} = 2.7\text{ V to }3.6\text{ V}$, $AV_{CC} = 2.7\text{ V to }3.6\text{ V}$, $V_{ref} = 2.7\text{ V to }AV_{CC}$, $V_{SS} = AV_{SS} = 0\text{ V}$, $\phi = 2\text{ MHz to }20\text{ MHz}$, $T_a = -20^\circ\text{C to }75^\circ\text{C}$ (regular specifications),
 $T_a = -40^\circ\text{C to }85^\circ\text{C}$ (wide-range specifications)

Condition B: $V_{CC} = 3.0\text{ V to }3.6\text{ V}$, $AV_{CC} = 3.0\text{ V to }3.6\text{ V}$, $V_{ref} = 3.0\text{ V to }AV_{CC}$, $V_{SS} = AV_{SS} = 0\text{ V}$, $\phi = 2\text{ MHz to }25\text{ MHz}$, $T_a = -20^\circ\text{C to }75^\circ\text{C}$ (regular specifications),
 $T_a = -40^\circ\text{C to }85^\circ\text{C}$ (wide-range specifications)

Item	Condition A			Condition B			Unit
	Min	Typ	Max	Min	Typ	Max	
Resolution	10	10	10	10	10	10	Bits
Conversion time	6.7	—	—	10.6	—	—	μs
Analog input capacitance	—	—	20	—	—	20	pF
Permissible signal source impedance	—	—	5	—	—	5	k Ω
Nonlinearity error	—	—	± 5.5	—	—	± 5.5	LSB
Offset error	—	—	± 5.5	—	—	± 5.5	LSB
Full-scale error	—	—	± 5.5	—	—	± 5.5	LSB
Quantization error	—	—	± 0.5	—	—	± 0.5	LSB
Absolute accuracy	—	—	± 6.0	—	—	± 6.0	LSB

20.1.5 D/A Conversion Characteristics

Table 20.9 D/A Conversion Characteristics

Condition A: $V_{CC} = 2.7\text{ V to }3.6\text{ V}$, $AV_{CC} = 2.7\text{ V to }3.6\text{ V}$, $V_{ref} = 2.7\text{ V to }AV_{CC}$, $V_{SS} = AV_{SS} = 0\text{ V}$, $\phi = 2\text{ MHz to }20\text{ MHz}$, $T_a = -20^\circ\text{C to }75^\circ\text{C}$ (regular specifications),
 $T_a = -40^\circ\text{C to }85^\circ\text{C}$ (wide-range specifications)

Condition B: $V_{CC} = 3.0\text{ V to }3.6\text{ V}$, $AV_{CC} = 3.0\text{ V to }3.6\text{ V}$, $V_{ref} = 3.0\text{ V to }AV_{CC}$, $V_{SS} = AV_{SS} = 0\text{ V}$, $\phi = 2\text{ MHz to }25\text{ MHz}$, $T_a = -20^\circ\text{C to }75^\circ\text{C}$ (regular specifications),
 $T_a = -40^\circ\text{C to }85^\circ\text{C}$ (wide-range specifications)

Item	Condition A			Condition B			Unit	Test Conditions
	Min	Typ	Max	Min	Typ	Max		
Resolution	8	8	8	8	8	8	Bits	
Conversion time	—	—	10	—	—	10	μs	20-pF capacitive load
Absolute accuracy	—	± 2.0	± 3.0	—	± 2.0	± 3.0	LSB	2-M Ω resistive load
	—	—	± 2.0	—	—	± 2.0	LSB	4-M Ω resistive load

20.2 Electrical Characteristics of F-ZTAT Versions (H8S/2319 F-ZTAT, H8S/2319E F-ZTAT, H8S/2318 F-ZTAT, H8S/2317 F-ZTAT, H8S/2315 F-ZTAT, H8S/2314 F-ZTAT)

20.2.1 Absolute Maximum Ratings

Table 20.10 Absolute Maximum Ratings

Condition B: $V_{CC} = 3.0\text{ V to }3.6\text{ V}$, $AV_{CC} = 3.0\text{ V to }3.6\text{ V}$, $V_{ref} = 3.0\text{ V to }AV_{CC}$, $V_{SS} = AV_{SS} = 0\text{ V}$, $T_a = -20^\circ\text{C to }75^\circ\text{C}$ (regular specifications), $T_a = -40^\circ\text{C to }85^\circ\text{C}$ (wide-range specifications)

Item	Symbol	Value	Unit
Power supply voltage	V_{CC}	-0.3 to +4.3	V
Input voltage (FWE, EMLE)	V_{in}	-0.3 to $V_{CC} + 0.3$	V
Input voltage (except port 4)	V_{in}	-0.3 to $V_{CC} + 0.3$	V
Input voltage (port 4)	V_{in}	-0.3 to $AV_{CC} + 0.3$	V
Reference power supply voltage	V_{ref}	-0.3 to $AV_{CC} + 0.3$	V
Analog power supply voltage	AV_{CC}	-0.3 to +4.3	V
Analog input voltage	V_{AN}	-0.3 to $AV_{CC} + 0.3$	V
Operating temperature	T_{opr}	Regular specifications: -20 to +75*	°C
		Wide-range specifications: -40 to +85*	°C
Storage temperature	T_{stg}	-55 to +125	°C

Caution: Permanent damage to the chip may result if absolute maximum ratings are exceeded.

Note: * Condition B: The operating temperature ranges for flash memory programming/erasing are $T_a = 0^\circ\text{C to }+75^\circ\text{C}$ (regular specifications), and $T_a = 0^\circ\text{C to }+85^\circ\text{C}$ (wide-range specifications).

20.2.2 DC Characteristics

Table 20.11 DC Characteristics

Condition B: $V_{CC} = 3.0\text{ V to }3.6\text{ V}$, $AV_{CC} = 3.0\text{ V to }3.6\text{ V}$, $V_{ref} = 3.0\text{ V to }AV_{CC}$,
 $V_{SS} = AV_{SS} = 0\text{ V}^{*1}$, $T_a = -20^\circ\text{C to }+75^\circ\text{C}$ (regular specifications),
 $T_a = -40^\circ\text{C to }+85^\circ\text{C}$ (wide-range specifications)

Item	Symbol	Min	Typ	Max	Unit	Test Conditions	
Schmitt trigger input voltage	Ports 1, 2, $\overline{IRQ0}$ to $\overline{IRQ7}$	V_T^-	$V_{CC} \times 0.2$	—	—	V	
		V_T^+	—	—	$V_{CC} \times 0.7$	V	
		$V_T^+ - V_T^-$	$V_{CC} \times 0.07$	—	—	V	
Input high voltage	\overline{RES} , \overline{STBY} , NMI, MD2 to MD0, FWE, EMLE	V_{IH}	$V_{CC} \times 0.9$	—	$V_{CC} + 0.3$	V	
	EXTAL		$V_{CC} \times 0.7$	—	$V_{CC} + 0.3$	V	
	Ports 3, A to G		2.2	—	$V_{CC} + 0.3$	V	
	Port 4		2.2	—	$AV_{CC} + 0.3$	V	
Input low voltage	\overline{RES} , \overline{STBY} , MD2 to MD0, FWE, EMLE	V_{IL}	-0.3	—	$V_{CC} \times 0.1$	V	
	NMI, EXTAL, ports 3, 4, A to G		-0.3	—	$V_{CC} \times 0.2$	V	
Output high voltage	All output pins	V_{OH}	$V_{CC} - 0.5$	—	—	V	$I_{OH} = -200\ \mu\text{A}$
			$V_{CC} - 1.0$	—	—	V	$I_{OH} = -1\ \text{mA}$
Output low voltage	All output pins	V_{OL}	—	—	0.4	V	$I_{OL} = 1.6\ \text{mA}$
Input leakage current	\overline{RES}	$ I_{in} $	—	—	10.0	μA	$V_{in} = 0.5\ \text{V to }V_{CC} - 0.5\ \text{V}$
	\overline{STBY} , NMI, MD2 to MD0, FWE, EMLE		—	—	1.0	μA	
	Port 4		—	—	1.0	μA	$V_{in} = 0.5\ \text{V to }AV_{CC} - 0.5\ \text{V}$

Item		Symbol	Min	Typ	Max	Unit	Test Conditions
Three-state leakage current (off state)	Ports 1, 2, 3, A to G	$ I_{TSI} $	—	—	1.0	μA	$V_{in} = 0.5\text{ V}$ to $V_{CC} - 0.5\text{ V}$
Input pull-up MOS current	Ports A to E	$-I_p$	10	—	300	μA	$V_{CC} = 3.0\text{ V}$ to 3.6 V , $V_{in} = 0\text{ V}$
Input capacitance	$\overline{\text{RES}}$	C_{in}	—	—	30	pF	$V_{in} = 0\text{ V}$
	NMI		—	—	30	pF	$f = 1\text{ MHz}$
	All input pins except $\overline{\text{RES}}$ and NMI		—	—	15	pF	$T_a = 25^\circ\text{C}$
Current dissipation*2	Normal operation	I_{CC}^{*4}	—	50 (3.3 V)	100	mA	$f = 25\text{ MHz}$
	Sleep mode		—	35 (3.3 V)	80	mA	
	Standby mode*3		—	0.01	10	μA	$T_a \leq 50^\circ\text{C}$
			—	—	80	μA	$50^\circ\text{C} < T_a$
Analog power supply voltage	During A/D and D/A conversion	AI_{CC}	—	0.2 (3.0 V)	2.0	mA	
	Idle		—	0.01	5.0	μA	
Reference power supply voltage	During A/D and D/A conversion	AI_{CC}	—	1.4 (3.0 V)	3.0	mA	
	Idle		—	0.01	5.0	μA	
RAM standby voltage		V_{RAM}	2.0	—	—	V	

- Notes: 1. **If the A/D and D/A converters are not used, do not leave the AV_{CC} , V_{ref} , and AV_{SS} pins open.** Connect the AV_{CC} and V_{ref} pins to V_{CC} , and the AV_{SS} pin to V_{SS} .
2. Current dissipation values are for $V_{IH\ min} = V_{CC} - 0.2\text{ V}$ and $V_{IL\ max} = 0.2\text{ V}$ with all output pins unloaded and all MOS input pull-ups in the off state.
3. The values are for $V_{RAM} \leq V_{CC} < 3.0\text{ V}$, $V_{IH\ min} = V_{CC} \times 0.9$, and $V_{IL\ max} = 0.3\text{ V}$.
4. I_{CC} depends on V_{CC} and f as follows:
 $I_{CC\ max} = 1.0\text{ (mA)} + 1.10\text{ (mA/(MHz} \times \text{V))} \times V_{CC} \times f$ (normal operation)
 $I_{CC\ max} = 1.0\text{ (mA)} + 0.88\text{ (mA/(MHz} \times \text{V))} \times V_{CC} \times f$ (sleep mode)

Table 20.12 Permissible Output Currents

Condition B: $V_{CC} = 3.0\text{ V to }3.6\text{ V}$, $AV_{CC} = 3.0\text{ to }3.6\text{ V}$, $V_{ref} = 3.0\text{ V to }AV_{CC}$,
 $V_{SS} = AV_{SS} = 0\text{ V}$, $T_a = -20\text{ to }+75^\circ\text{C}$ (regular specifications),
 $T_a = -40\text{ to }+85^\circ\text{C}$ (wide-range specifications)

Item		Symbol	Min	Typ	Max	Unit
Permissible output low current (per pin)	All output pins	I_{OL}	—	—	2.0	mA
Permissible output low current (total)	Total of all output pins	ΣI_{OL}	—	—	80	mA
Permissible output high current (per pin)	All output pins	$-I_{OH}$	—	—	2.0	mA
Permissible output high current (total)	Total of all output pins	$\Sigma -I_{OH}$	—	—	40	mA

Note: To protect chip reliability, do not exceed the output current values in table 20.12.

20.2.3 AC Characteristics

(1) Clock Timing

Table 20.13 Clock Timing

Condition B: $V_{CC} = 3.0\text{ V to }3.6\text{ V}$, $AV_{CC} = 3.0\text{ V to }3.6\text{ V}$, $V_{ref} = 3.0\text{ V to }AV_{CC}$, $V_{SS} = AV_{SS} = 0\text{ V}$, $\phi = 2\text{ MHz to }25\text{ MHz}$, $T_a = -20^\circ\text{C to }75^\circ\text{C}$ (regular specifications),
 $T_a = -40^\circ\text{C to }85^\circ\text{C}$ (wide-range specifications)

Item	Symbol	Min	Max	Unit	Test Conditions
Clock cycle time	t_{cyc}	40	500	ns	Figure 20.2
Clock pulse high width	t_{CH}	15	—	ns	
Clock pulse low width	t_{CL}	15	—	ns	
Clock rise time	t_{Cr}	—	5	ns	
Clock fall time	t_{Cf}	—	5	ns	
Reset oscillation stabilization time (crystal)	t_{OSC1}	10	—	ms	Figure 20.3
Software standby oscillation stabilization time (crystal)	t_{OSC2}	10	—	ms	
External clock output stabilization delay time	t_{DEXT}	500	—	μs	Figure 20.3

(2) Control Signal Timing**Table 20.14 Control Signal Timing**

Condition B: $V_{CC} = 3.0\text{ V to }3.6\text{ V}$, $AV_{CC} = 3.0\text{ V to }3.6\text{ V}$, $V_{ref} = 3.0\text{ V to }AV_{CC}$, $V_{SS} = AV_{SS} = 0\text{ V}$, $\phi = 2\text{ MHz to }25\text{ MHz}$, $T_a = -20^\circ\text{C to }75^\circ\text{C}$ (regular specifications),
 $T_a = -40^\circ\text{C to }85^\circ\text{C}$ (wide-range specifications)

Item	Symbol	Min	Max	Unit	Test Conditions
$\overline{\text{RES}}$ setup time	t_{RESS}	200	—	ns	Figure 20.4
$\overline{\text{RES}}$ pulse width	t_{RESW}	20	—	t_{cyc}	
NMI setup time	t_{NMIS}	150	—	ns	Figure 20.5
NMI hold time	t_{NMIH}	10	—	ns	
NMI pulse width (in recovery from software standby mode)	t_{NMIW}	200	—	ns	
$\overline{\text{IRQ}}$ setup time	t_{IRQS}	150	—	ns	
$\overline{\text{IRQ}}$ hold time	t_{IRQH}	10	—	ns	
$\overline{\text{IRQ}}$ pulse width (in recovery from software standby mode)	t_{IRQW}	200	—	ns	

(3) Bus Timing**Table 20.15 Bus Timing**

Condition B: $V_{CC} = 3.0\text{ V to }3.6\text{ V}$, $AV_{CC} = 3.0\text{ V to }3.6\text{ V}$, $V_{ref} = 3.0\text{ V to }AV_{CC}$, $V_{SS} = AV_{SS} = 0\text{ V}$, $\phi = 2\text{ MHz to }25\text{ MHz}$, $T_a = -20^\circ\text{C to }75^\circ\text{C}$ (regular specifications),
 $T_a = -40^\circ\text{C to }85^\circ\text{C}$ (wide-range specifications)

Item	Symbol	Min	Max	Unit	Test Conditions
Address delay time	t_{AD}	—	20	ns	Figures 20.6 to 20.10
Address setup time	t_{AS}	$0.5 \times t_{cyc} - 15$	—	ns	
Address hold time	t_{AH}	$0.5 \times t_{cyc} - 8$	—	ns	
\overline{CS} delay time 1	t_{CSD1}	—	15	ns	
\overline{AS} delay time	t_{ASD}	—	15	ns	
\overline{RD} delay time 1	t_{RSD1}	—	15	ns	
\overline{RD} delay time 2	t_{RSD2}	—	15	ns	
Read data setup time	t_{RDS}	15	—	ns	
Read data hold time	t_{RDH}	0	—	ns	
Read data access time 1	t_{ACC1}	—	$1.0 \times t_{cyc} - 20$	ns	
Read data access time 2	t_{ACC2}	—	$1.5 \times t_{cyc} - 20$	ns	
Read data access time 3	t_{ACC3}	—	$2.0 \times t_{cyc} - 20$	ns	
Read data access time 4	t_{ACC4}	—	$2.5 \times t_{cyc} - 20$	ns	
Read data access time 5	t_{ACC5}	—	$3.0 \times t_{cyc} - 20$	ns	
\overline{WR} delay time 1	t_{WRD1}	—	15	ns	
\overline{WR} delay time 2	t_{WRD2}	—	15	ns	
\overline{WR} pulse width 1	t_{WSW1}	$1.0 \times t_{cyc} - 15$	—	ns	
\overline{WR} pulse width 2	t_{WSW2}	$1.5 \times t_{cyc} - 15$	—	ns	
Write data delay time	t_{WDD}	—	20	ns	
Write data setup time	t_{WDS}	$0.5 \times t_{cyc} - 15$	—	ns	
Write data hold time	t_{WDH}	$0.5 \times t_{cyc} - 8$	—	ns	
\overline{WAIT} setup time	t_{WTS}	25	—	ns	Figure 20.8
\overline{WAIT} hold time	t_{WTH}	5	—	ns	
\overline{BREQ} setup time	t_{BRQS}	30	—	ns	Figure 20.11
\overline{BACK} delay time	t_{BACD}	—	15	ns	
Bus floating time	t_{BZD}	—	40	ns	
\overline{BREQO} delay time	t_{BRQOD}	—	25	ns	Figure 20.12

(4) Timing of On-Chip Supporting Modules**Table 20.16 Timing of On-Chip Supporting Modules**

Condition B: $V_{CC} = 3.0\text{ V to }3.6\text{ V}$, $AV_{CC} = 3.0\text{ V to }3.6\text{ V}$, $V_{ref} = 3.0\text{ V to }AV_{CC}$, $V_{SS} = AV_{SS} = 0\text{ V}$, $\phi = 2\text{ MHz to }25\text{ MHz}$, $T_a = -20^\circ\text{C to }75^\circ\text{C}$ (regular specifications),
 $T_a = -40^\circ\text{C to }85^\circ\text{C}$ (wide-range specifications)

Item		Symbol	Min	Max	Unit	Test Conditions	
I/O ports	Output data delay time	t_{PWD}	—	40	ns	Figure 20.13	
	Input data setup time	t_{PRS}	25	—	ns		
	Input data hold time	t_{PRH}	25	—	ns		
TPU	Timer output delay time	t_{TOCD}	—	40	ns	Figure 20.14	
	Timer input setup time	t_{TICS}	25	—	ns		
	Timer clock input setup time	t_{TCKS}	25	—	ns	Figure 20.15	
	Timer clock pulse width	Single-edge specification	t_{TCKWH}	1.5	—		t_{cyc}
		Both-edge specification	t_{TCKWL}	2.5	—		t_{cyc}
8-bit timer	Timer output delay time	t_{TMOD}	—	40	ns	Figure 20.16	
	Timer reset input setup time	t_{TMRS}	25	—	ns		Figure 20.18
	Timer clock input setup time	t_{TMCS}	25	—	ns	Figure 20.17	
	Timer clock pulse width	Single-edge specification	t_{TMCWH}	1.5	—		t_{cyc}
		Both-edge specification	t_{TMCWL}	2.5	—		t_{cyc}
SCI	Input clock cycle	Asynchronous	t_{Scyc}	4	—	t_{cyc}	Figure 20.20
		Synchronous		6	—		
	Input clock pulse width	t_{SCKW}	0.4	0.6	t_{Scyc}		
	Input clock rise time	t_{SCKr}	—	1.5	t_{cyc}		
	Input clock fall time	t_{SCKf}	—	1.5	t_{cyc}		
	Transmit data delay time	t_{TXD}	—	40	ns	Figure 20.21	
	Receive data setup time (synchronous)	t_{RXS}	40	—	ns		
Receive data hold time (synchronous)	t_{RXH}	40	—	ns			
A/D converter	Trigger input setup time	t_{TRGS}	30	—	ns	Figure 20.22	

20.2.4 A/D Conversion Characteristics

Table 20.17 A/D Conversion Characteristics

Condition B: $V_{CC} = 3.0\text{ V to }3.6\text{ V}$, $AV_{CC} = 3.0\text{ V to }3.6\text{ V}$, $V_{ref} = 3.0\text{ V to }AV_{CC}$, $V_{SS} = AV_{SS} = 0\text{ V}$, $\phi = 2\text{ MHz to }25\text{ MHz}$, $T_a = -20^\circ\text{C to }75^\circ\text{C}$ (regular specifications),
 $T_a = -40^\circ\text{C to }85^\circ\text{C}$ (wide-range specifications)

Item	Min	Typ	Max	Unit
Resolution	10	10	10	Bits
Conversion time	10.6	—	—	μs
Analog input capacitance	—	—	20	pF
Permissible signal source impedance	—	—	5	$\text{k}\Omega$
Nonlinearity error	—	—	± 5.5	LSB
Offset error	—	—	± 5.5	LSB
Full-scale error	—	—	± 5.5	LSB
Quantization error	—	—	± 0.5	LSB
Absolute accuracy	—	—	± 6.0	LSB

20.2.5 D/A Conversion Characteristics

Table 20.18 D/A Conversion Characteristics

Condition B: $V_{CC} = 3.0\text{ V to }3.6\text{ V}$, $AV_{CC} = 3.0\text{ V to }3.6\text{ V}$, $V_{ref} = 3.0\text{ V to }AV_{CC}$, $V_{SS} = AV_{SS} = 0\text{ V}$, $\phi = 2\text{ MHz to }25\text{ MHz}$, $T_a = -20^\circ\text{C to }75^\circ\text{C}$ (regular specifications),
 $T_a = -40^\circ\text{C to }85^\circ\text{C}$ (wide-range specifications)

Item	Min	Typ	Max	Unit	Test Conditions
Resolution	8	8	8	Bits	
Conversion time	—	—	10	μs	20-pF capacitive load
Absolute accuracy	—	± 2.0	± 3.0	LSB	2-M Ω resistive load
	—	—	± 2.0	LSB	4-M Ω resistive load

20.2.6 Flash Memory Characteristics

Table 20.19 Flash Memory Characteristics

Condition B: $V_{CC} = 3.0\text{ V to }3.6\text{ V}$, $AV_{CC} = 3.0\text{ V to }3.6\text{ V}$, $V_{ref} = 3.0\text{ V to }AV_{CC}$, $V_{SS} = AV_{SS} = 0\text{ V}$, $T_a = 0^\circ\text{C to }+75^\circ\text{C}$ (program/erase operating temperature range: regular specifications), $T_a = 0^\circ\text{C to }+85^\circ\text{C}$ (program/erase operating temperature range: wide-range specifications)

Item	Symbol	Min	Typ	Max	Unit	Test Conditions	
Programming time ^{*1 *2 *4}	t_P	—	10	200	ms/ 128 bytes		
Erase time ^{*1 *3 *6}	t_E	—	50	1000	ms/block		
Reprogramming count	N_{WEC}	100 ^{*7}	10000 ^{*8}	—	Times		
Data retention time ^{*9}	t_{DRP}	10	—	—	Years		
Programming	Wait time after SWE bit setting ^{*1}	x	1	—	—	μs	
	Wait time after PSU bit setting ^{*1}	y	50	—	—	μs	
	Wait time after P bit setting ^{*1 *4}	z (z1)	—	—	30	μs	$1 \leq n \leq 6$
			—	—	200	μs	$7 \leq n \leq 1000$
			—	—	10	μs	Additional-programming time wait
	Wait time after P bit clearing ^{*1}	α	5	—	—	μs	
	Wait time after PSU bit clearing ^{*1}	β	5	—	—	μs	
	Wait time after PV bit setting ^{*1}	γ	4	—	—	μs	
	Wait time after H'FF dummy write ^{*1}	ε	2	—	—	μs	
	Wait time after PV bit clearing ^{*1}	η	2	—	—	μs	
Wait time after SWE bit clearing ^{*1}	θ	100	—	—	μs		
Maximum number of writes ^{*1 *4}	N	—	—	1000 ^{*5}	Times		
Erasing	Wait time after SWE bit setting ^{*1}	x	1	—	—	μs	
	Wait time after ESU bit setting ^{*1}	y	100	—	—	μs	
	Wait time after E bit setting ^{*1 *6}	z	—	—	10	μs	
	Wait time after E bit clearing ^{*1}	α	10	—	—	μs	
	Wait time after ESU bit clearing ^{*1}	β	10	—	—	μs	
	Wait time after EV bit setting ^{*1}	γ	20	—	—	μs	
	Wait time after H'FF dummy write ^{*1}	ε	2	—	—	μs	
	Wait time after EV bit clearing ^{*1}	η	4	—	—	μs	
	Wait time after SWE bit clearing ^{*1}	θ	100	—	—	μs	
Maximum number of erases ^{*1 *6}	N	—	—	100	Times		

- Notes:
1. Follow the program/erase algorithms when making the time settings.
 2. Programming time per 128 bytes. (In the H8S/2318, H8S/2317, H8S/2315, and H8S/2314, indicates the total time during which the P bit in flash memory control register 1 (FLMCR1) is set. In the H8S/2319, indicates the total time during which the P1 bit and P2 bit in the flash memory control registers (FLMCR1, FLMCR2) are set. Does not include the program-verify time.)
 3. Time to erase one block. (In the H8S/2318, H8S/2317, H8S/2315, and H8S/2314, indicates the total time during which the E1 bit in FLMCR1 and the E2 bit in FLMCR2 are set. Does not include the erase-verify time.)

4. Maximum programming time

$$t_{P(\max)} = \sum_{i=1}^N \text{wait time after P bit setting (z)}$$

5. The maximum number of writes (N) should be set as shown below according to the actual set value of z so as not to exceed the maximum programming time ($t_{P(\max)}$). The wait time after P bit setting (z) should be changed as follows according to the number of writes (n).

Number of writes (n)

$$1 \leq n \leq 6 \quad z = 30 \mu\text{s}$$

$$7 \leq n \leq 1000 \quad z = 200 \mu\text{s}$$

[In additional programming]

Number of writes (n)

$$1 \leq n \leq 6 \quad z = 10 \mu\text{s}$$

6. For the maximum erase time ($t_{E(\max)}$), the following relationship applies between the wait time after E bit setting (z) and the maximum number of erases (N):

$$t_{E(\max)} = \text{Wait time after E bit setting (z)} \times \text{maximum number of erases (N)}$$
7. Minimum number of times for which all characteristics are guaranteed after rewriting (Guarantee range is 1 to minimum value).
8. Reference value for 25°C (as a guideline, rewriting should normally function up to this value).
9. Data retention characteristic when rewriting is performed within the specification range, including the minimum value.

20.3 Electrical Characteristics of F-ZTAT Version (H8S/2319C F-ZTAT)

20.3.1 Absolute Maximum Ratings

Table 20.20 Absolute Maximum Ratings

Condition B: $V_{CC} = 3.0\text{ V to }3.6\text{ V}$, $AV_{CC} = 3.0\text{ V to }3.6\text{ V}$, $V_{ref} = 3.0\text{ V to }AV_{CC}$, $V_{SS} = AV_{SS} = 0\text{ V}$, $T_a = -20^{\circ}\text{C to }75^{\circ}\text{C}$ (regular specifications), $T_a = -40^{\circ}\text{C to }85^{\circ}\text{C}$ (wide-range specifications)

Item	Symbol	Value	Unit
Power supply voltage	V_{CC}^{*1}	-0.3 to +4.3	V
Input voltage (except port 4)	V_{in}	-0.3 to $V_{CC} + 0.3$	V
Input voltage (port 4)	V_{in}	-0.3 to $AV_{CC} + 0.3$	V
Reference power supply voltage	V_{ref}	-0.3 to $AV_{CC} + 0.3$	V
Analog power supply voltage	AV_{CC}	-0.3 to +4.3	V
Analog input voltage	V_{AN}	-0.3 to $AV_{CC} + 0.3$	V
Operating temperature	T_{opr}	Regular specifications: -20 to +75 ^{*2}	°C
		Wide-range specifications: -40 to +85 ^{*2}	°C
Storage temperature	T_{stg}	-55 to +125	°C

Caution: Permanent damage to the chip may result if absolute maximum ratings are exceeded.

- Notes:
1. Do not apply the power supply voltage to the V_{CL} pin. Doing so could permanently damage the LSI. An external capacitor should be connected between this pin and GND.
 2. The operating temperature ranges for flash memory programming/erasing are $T_a = 0^{\circ}\text{C}$ to $+75^{\circ}\text{C}$ (regular specifications), and $T_a = 0^{\circ}\text{C}$ to $+85^{\circ}\text{C}$ (wide-range specifications).

20.3.2 DC Characteristics

Table 20.21 DC Characteristics

Condition B: $V_{CC} = 3.0\text{ V to }3.6\text{ V}$, $AV_{CC} = 3.0\text{ V to }3.6\text{ V}$, $V_{ref} = 3.0\text{ V to }AV_{CC}$,
 $V_{SS} = AV_{SS} = 0\text{ V}^{*1}$, $T_a = -20^{\circ}\text{C to }+75^{\circ}\text{C}$ (regular specifications),
 $T_a = -40^{\circ}\text{C to }+85^{\circ}\text{C}$ (wide-range specifications)

Item		Symbol	Min	Typ	Max	Unit	Test Conditions
Schmitt trigger input voltage	Ports 1, 2, $\overline{\text{IRQ0}}$ to $\overline{\text{IRQ7}}$	V_T^-	$V_{CC} \times 0.2$	—	—	V	
		V_T^+	—	—	$V_{CC} \times 0.7$	V	
		$V_T^+ - V_T^-$	$V_{CC} \times 0.07$	—	—	V	
Input high voltage	$\overline{\text{RES}}$, $\overline{\text{STBY}}$, NMI, MD2 to MD0	V_{IH}	$V_{CC} \times 0.9$	—	$V_{CC} + 0.3$	V	
	$\overline{\text{EXTAL}}$		$V_{CC} \times 0.7$	—	$V_{CC} + 0.3$	V	
	Ports 3, A to G		2.2	—	$V_{CC} + 0.3$	V	
	Port 4		2.2	—	$AV_{CC} + 0.3$	V	
Input low voltage	$\overline{\text{RES}}$, $\overline{\text{STBY}}$, MD2 to MD0	V_{IL}	-0.3	—	$V_{CC} \times 0.1$	V	
	NMI, $\overline{\text{EXTAL}}$, ports 3, 4, A to G		-0.3	—	$V_{CC} \times 0.2$	V	
Output high voltage	All output pins	V_{OH}	$V_{CC} - 0.5$	—	—	V	$I_{OH} = -200\ \mu\text{A}$
			$V_{CC} - 1.0$	—	—	V	$I_{OH} = -1\ \text{mA}$
Output low voltage	All output pins	V_{OL}	—	—	0.4	V	$I_{OL} = 1.6\ \text{mA}$
Input leakage current	$\overline{\text{RES}}$	$ I_{in} $	—	—	10.0	μA	$V_{in} = 0.5\ \text{V to }V_{CC} - 0.5\ \text{V}$
	$\overline{\text{STBY}}$, NMI, MD2 to MD0		—	—	1.0	μA	
	Port 4		—	—	1.0	μA	$V_{in} = 0.5\ \text{V to }AV_{CC} - 0.5\ \text{V}$
Three-state leakage current (off state)	Ports 1 to 3, A to G	$ I_{TSI} $	—	—	1.0	μA	$V_{in} = 0.5\ \text{V to }V_{CC} - 0.5\ \text{V}$

Item		Symbol	Min	Typ	Max	Unit	Test Conditions
Input pull-up MOS current	Ports A to E	$-I_p$	10	—	300	μA	$V_{CC} = 3.0\text{ V}$ to 3.6 V , $V_{in} = 0\text{ V}$
Input capacitance	$\overline{\text{RES}}$	C_{in}	—	—	30	pF	$V_{in} = 0\text{ V}$
	NMI		—	—	30	pF	$f = 1\text{ MHz}$
	All input pins except RES and NMI		—	—	15	pF	$T_a = 25^\circ\text{C}$
Current dissipation*2	Normal operation	I_{CC} *4	—	25 (3.3 V)	50	mA	$f = 25\text{ MHz}$
	Sleep mode		—	17 (3.3 V)	40	mA	
	Standby mode*3		—	20	90	μA	$T_a \leq 50^\circ\text{C}$
			—	—	120	μA	$50^\circ\text{C} < T_a$
Analog power supply voltage	During A/D and D/A conversion	AI_{CC}	—	1.0 (3.0 V)	2.0	mA	
	Idle		—	1.0	5.0	μA	
Reference power supply voltage	During A/D and D/A conversion	AI_{CC}	—	1.4 (3.0 V)	3.0	mA	
	Idle		—	0.2	5.0	μA	
RAM standby voltage		V_{RAM}	2.5	—	—	V	
VCC start voltage*5		V_{CC_START}	—	—	0.4	V	
VCC rising edge*5		SVCC	—	—	10	ms/V	

- Notes: 1. **If the A/D and D/A converters are not used, do not leave the AV_{CC} , V_{ref} , and AV_{SS} pins open.** Connect the AV_{CC} and V_{ref} pins to V_{CC} , and the AV_{SS} pin to V_{SS} .
2. Current dissipation values are for $V_{IH\ min} = V_{CC} - 0.2\text{ V}$ and $V_{IL\ max} = 0.2\text{ V}$ with all output pins unloaded and all MOS input pull-ups in the off state.
3. The values are for $V_{RAM} \leq V_{CC} < 3.0\text{ V}$, $V_{IH\ min} = V_{CC} \times 0.9$, and $V_{IL\ max} = 0.3\text{ V}$.
4. I_{CC} depends on V_{CC} and f as follows:
 $I_{CC\ max} = 0.5\text{ (mA)} + 0.55\text{ (mA/(MHz} \times \text{V))} \times V_{CC} \times f$ (normal operation)
 $I_{CC\ max} = 0.4\text{ (mA)} + 0.44\text{ (mA/(MHz} \times \text{V))} \times V_{CC} \times f$ (sleep mode)
5. Applies on condition that the $\overline{\text{RES}}$ pin is low level at power on.

Table 20.22 Permissible Output Currents

Condition B: $V_{CC} = 3.0\text{ V to }3.6\text{ V}$, $AV_{CC} = 3.0\text{ to }3.6\text{ V}$, $V_{ref} = 3.0\text{ V to }AV_{CC}$,
 $V_{SS} = AV_{SS} = 0\text{ V}$, $T_a = -20\text{ to }+75^\circ\text{C}$ (regular specifications),
 $T_a = -40\text{ to }+85^\circ\text{C}$ (wide-range specifications)

Item		Symbol	Min	Typ	Max	Unit
Permissible output low current (per pin)	All output pins	I_{OL}	—	—	2.0	mA
Permissible output low current (total)	Total of all output pins	ΣI_{OL}	—	—	80	mA
Permissible output high current (per pin)	All output pins	$-I_{OH}$	—	—	2.0	mA
Permissible output high current (total)	Total of all output pins	$\Sigma -I_{OH}$	—	—	40	mA

Note: To protect chip reliability, do not exceed the output current values in table 20.22.

20.3.3 AC Characteristics

(1) Clock Timing

Table 20.23 Clock Timing

Condition B: $V_{CC} = 3.0\text{ V to }3.6\text{ V}$, $AV_{CC} = 3.0\text{ V to }3.6\text{ V}$, $V_{ref} = 3.0\text{ V to }AV_{CC}$, $V_{SS} = AV_{SS} = 0\text{ V}$, $\phi = 2\text{ MHz to }25\text{ MHz}$, $T_a = -20^\circ\text{C to }75^\circ\text{C}$ (regular specifications),
 $T_a = -40^\circ\text{C to }85^\circ\text{C}$ (wide-range specifications)

Item	Symbol	Min	Max	Unit	Test Conditions
Clock cycle time	t_{cyc}	40	500	ns	Figure 20.2
Clock pulse high width	t_{CH}	15	—	ns	
Clock pulse low width	t_{CL}	15	—	ns	
Clock rise time	t_{Cr}	—	5	ns	
Clock fall time	t_{Cf}	—	5	ns	
Reset oscillation stabilization time (crystal)	t_{OSC1}	10	—	ms	Figure 20.3
Software standby oscillation stabilization time (crystal)	t_{OSC2}	10	—	ms	
External clock output stabilization delay time	t_{DEXT}	500	—	μs	Figure 20.3

(2) Control Signal Timing**Table 20.24 Control Signal Timing**

Condition B: $V_{CC} = 3.0\text{ V to }3.6\text{ V}$, $AV_{CC} = 3.0\text{ V to }3.6\text{ V}$, $V_{ref} = 3.0\text{ V to }AV_{CC}$, $V_{SS} = AV_{SS} = 0\text{ V}$, $\phi = 2\text{ MHz to }25\text{ MHz}$, $T_a = -20^\circ\text{C to }75^\circ\text{C}$ (regular specifications),
 $T_a = -40^\circ\text{C to }85^\circ\text{C}$ (wide-range specifications)

Item	Symbol	Min	Max	Unit	Test Conditions
$\overline{\text{RES}}$ setup time	t_{RESS}	200	—	ns	Figure 20.4
$\overline{\text{RES}}$ pulse width	t_{RESW}	20	—	t_{cyc}	
NMI setup time	t_{NMIS}	150	—	ns	Figure 20.5
NMI hold time	t_{NMIH}	10	—	ns	
NMI pulse width (in recovery from software standby mode)	t_{NMIW}	200	—	ns	
$\overline{\text{IRQ}}$ setup time	t_{IRQS}	150	—	ns	
$\overline{\text{IRQ}}$ hold time	t_{IRQH}	10	—	ns	
$\overline{\text{IRQ}}$ pulse width (in recovery from software standby mode)	t_{IRQW}	200	—	ns	

(3) Bus Timing**Table 20.25 Bus Timing**

Condition B: $V_{CC} = 3.0\text{ V to }3.6\text{ V}$, $AV_{CC} = 3.0\text{ V to }3.6\text{ V}$, $V_{ref} = 3.0\text{ V to }AV_{CC}$, $V_{SS} = AV_{SS} = 0\text{ V}$, $\phi = 2\text{ MHz to }25\text{ MHz}$, $T_a = -20^\circ\text{C to }75^\circ\text{C}$ (regular specifications),
 $T_a = -40^\circ\text{C to }85^\circ\text{C}$ (wide-range specifications)

Item	Symbol	Min	Max	Unit	Test Conditions
Address delay time	t_{AD}	—	20	ns	Figures 20.6 to 20.10
Address setup time	t_{AS}	$0.5 \times t_{cyc} - 15$	—	ns	
Address hold time	t_{AH}	$0.5 \times t_{cyc} - 8$	—	ns	
\overline{CS} delay time 1	t_{CSD1}	—	15	ns	
\overline{AS} delay time	t_{ASD}	—	15	ns	
\overline{RD} delay time 1	t_{RSD1}	—	15	ns	
\overline{RD} delay time 2	t_{RSD2}	—	15	ns	
Read data setup time	t_{RDS}	15	—	ns	
Read data hold time	t_{RDH}	0	—	ns	
Read data access time 1	t_{ACC1}	—	$1.0 \times t_{cyc} - 20$	ns	
Read data access time 2	t_{ACC2}	—	$1.5 \times t_{cyc} - 20$	ns	
Read data access time 3	t_{ACC3}	—	$2.0 \times t_{cyc} - 20$	ns	
Read data access time 4	t_{ACC4}	—	$2.5 \times t_{cyc} - 20$	ns	
Read data access time 5	t_{ACC5}	—	$3.0 \times t_{cyc} - 20$	ns	
\overline{WR} delay time 1	t_{WRD1}	—	15	ns	
\overline{WR} delay time 2	t_{WRD2}	—	15	ns	
\overline{WR} pulse width 1	t_{WSW1}	$1.0 \times t_{cyc} - 15$	—	ns	
\overline{WR} pulse width 2	t_{WSW2}	$1.5 \times t_{cyc} - 15$	—	ns	
Write data delay time	t_{WDD}	—	20	ns	
Write data setup time	t_{WDS}	$0.5 \times t_{cyc} - 15$	—	ns	
Write data hold time	t_{WDH}	$0.5 \times t_{cyc} - 8$	—	ns	
\overline{WAIT} setup time	t_{WTS}	25	—	ns	Figure 20.8
\overline{WAIT} hold time	t_{WTH}	5	—	ns	
\overline{BREQ} setup time	t_{BRQS}	30	—	ns	Figure 20.11
\overline{BACK} delay time	t_{BACD}	—	15	ns	
Bus floating time	t_{BZD}	—	40	ns	
\overline{BREQO} delay time	t_{BRQOD}	—	25	ns	Figure 20.12

(4) Timing of On-Chip Supporting Modules**Table 20.26 Timing of On-Chip Supporting Modules**

Condition B: $V_{CC} = 3.0\text{ V to }3.6\text{ V}$, $AV_{CC} = 3.0\text{ V to }3.6\text{ V}$, $V_{ref} = 3.0\text{ V to }AV_{CC}$, $V_{SS} = AV_{SS} = 0\text{ V}$, $\phi = 2\text{ MHz to }25\text{ MHz}$, $T_a = -20^\circ\text{C to }75^\circ\text{C}$ (regular specifications),
 $T_a = -40^\circ\text{C to }85^\circ\text{C}$ (wide-range specifications)

Item		Symbol	Min	Max	Unit	Test Conditions	
I/O ports	Output data delay time	t_{PWD}	—	40	ns	Figure 20.13	
	Input data setup time	t_{PRS}	25	—	ns		
	Input data hold time	t_{PRH}	25	—	ns		
TPU	Timer output delay time	t_{TOCD}	—	40	ns	Figure 20.14	
	Timer input setup time	t_{TICS}	25	—	ns		
	Timer clock input setup time	t_{TCKS}	25	—	ns	Figure 20.15	
	Timer clock pulse width	Single-edge specification	t_{TCKWH}	1.5	—		t_{cyc}
		Both-edge specification	t_{TCKWL}	2.5	—		t_{cyc}
8-bit timer	Timer output delay time	t_{TMOD}	—	40	ns	Figure 20.16	
	Timer reset input setup time	t_{TMRS}	25	—	ns	Figure 20.18	
	Timer clock input setup time	t_{TMCS}	25	—	ns	Figure 20.17	
	Timer clock pulse width	Single-edge specification	t_{TMCWH}	1.5	—	t_{cyc}	
		Both-edge specification	t_{TMCWL}	2.5	—	t_{cyc}	
SCI	Input clock cycle	Asynchronous	t_{Seyc}	4	—	t_{cyc}	Figure 20.20
		Synchronous		6	—	t_{cyc}	
	Input clock pulse width	t_{SCKW}	0.4	0.6	t_{Seyc}		
	Input clock rise time	t_{SCKr}	—	1.5	t_{cyc}		
	Input clock fall time	t_{SCKf}	—	1.5	t_{cyc}		
	Transmit data delay time	t_{TXD}	—	40	ns	Figure 20.21	
	Receive data setup time (synchronous)	t_{RXS}	40	—	ns		
Receive data hold time (synchronous)	t_{RXH}	40	—	ns			
A/D converter	Trigger input setup time	t_{TRGS}	30	—	ns	Figure 20.22	

20.3.4 A/D Conversion Characteristics

Table 20.27 A/D Conversion Characteristics

Condition B: $V_{CC} = 3.0\text{ V to }3.6\text{ V}$, $AV_{CC} = 3.0\text{ V to }3.6\text{ V}$, $V_{ref} = 3.0\text{ V to }AV_{CC}$, $V_{SS} = AV_{SS} = 0\text{ V}$, $\phi = 2\text{ MHz to }25\text{ MHz}$, $T_a = -20^\circ\text{C to }75^\circ\text{C}$ (regular specifications),
 $T_a = -40^\circ\text{C to }85^\circ\text{C}$ (wide-range specifications)

Item	Min	Typ	Max	Unit
Resolution	10	10	10	Bits
Conversion time	10.6	—	—	μs
Analog input capacitance	—	—	20	pF
Permissible signal source impedance	—	—	5	k Ω
Nonlinearity error	—	—	± 5.5	LSB
Offset error	—	—	± 5.5	LSB
Full-scale error	—	—	± 5.5	LSB
Quantization error	—	—	± 0.5	LSB
Absolute accuracy	—	—	± 6.0	LSB

20.3.5 D/A Conversion Characteristics

Table 20.28 D/A Conversion Characteristics

Condition B: $V_{CC} = 3.0\text{ V to }3.6\text{ V}$, $AV_{CC} = 3.0\text{ V to }3.6\text{ V}$, $V_{ref} = 3.0\text{ V to }AV_{CC}$, $V_{SS} = AV_{SS} = 0\text{ V}$, $\phi = 2\text{ MHz to }25\text{ MHz}$, $T_a = -20^\circ\text{C to }75^\circ\text{C}$ (regular specifications),
 $T_a = -40^\circ\text{C to }85^\circ\text{C}$ (wide-range specifications)

Item	Min	Typ	Max	Unit	Test Conditions
Resolution	8	8	8	Bits	
Conversion time	—	—	10	μs	20-pF capacitive load
Absolute accuracy	—	± 2.0	± 3.0	LSB	2-M Ω resistive load
	—	—	± 2.0	LSB	4-M Ω resistive load

20.3.6 Flash Memory Characteristics

Table 20.29 Flash Memory Characteristics

Condition B: $V_{CC} = 3.0\text{ V to }3.6\text{ V}$, $AV_{CC} = 3.0\text{ V to }3.6\text{ V}$, $V_{ref} = 3.0\text{ V to }AV_{CC}$, $V_{SS} = AV_{SS} = 0\text{ V}$, $T_a = 0^\circ\text{C to }+75^\circ\text{C}$ (program/erase operating temperature range: regular specifications), $T_a = 0^\circ\text{C to }+85^\circ\text{C}$ (program/erase operating temperature range: wide-range specifications)

Item	Symbol	Min	Typ	Max	Unit	Test Conditions
Programming time ^{*1 *2 *4}	t_P	—	3	30	ms/128 bytes	
Erase time ^{*1 *3 *4}	t_E	—	80	800	ms/4-kbyte block	
		—	500	5000	ms/32-kbyte block	
		—	1000	10000	ms/64-kbyte block	
Programming time (total) ^{*1 *2 *4}	Σt_P	—	10	30	s/512 kbytes	$T_a = 25^\circ\text{C}$ when all cleared to 0
Erase time (total) ^{*1 *2 *4}	Σt_E	—	10	30	s/512 kbytes	$T_a = 25^\circ\text{C}$
Programming and erase time (total) ^{*1 *2 *4}	Σt_{PE}	—	20	60	s/512 kbytes	
Number of overwrites	NWEC	100^{*3}	10000^{*5}	—	Times	
Data retention time ^{*4}	t_{DRP}	10	—	—	Years	

- Notes:
1. The exact programming and erase times depend on the characteristics of the data.
 2. Programming and erase times do not include data transfer time.
 3. This is the minimum number of rewrites after which all characteristics are guaranteed. (The guaranteed range is 1 to minimum.)
 4. This characteristic applies when the number of rewrites is within the specification range, including minimum values.
 5. Reference value for 25°C (as a guideline, rewriting should normally function up to this value).

20.3.7 Usage Note (Internal voltage step down for the H8S/2319C F-ZTAT)

The H8S/2319C F-ZTAT has an on-chip voltage step down circuit that automatically lowers the power supply voltage, inside the microcomputer, to an adequate level. A capacitor (0.1 μF) should be connected between the internal voltage step down circuit pin (V_{CL} pin) and the V_{SS} pin to stabilize the internal voltage. Figure 20.23 shows how to connect the capacitor. Do not connect the V_{CC} power supply to the V_{CL} pin. Doing so could permanently damage the LSI. (Connect the V_{CC} power-supply to the V_{CC} pin, in the usual way.)

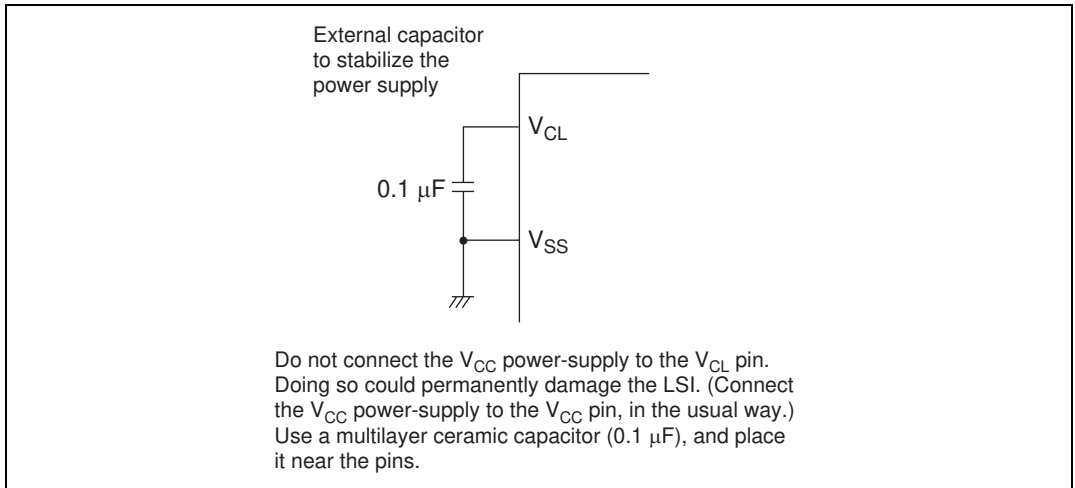

Figure 20.23 V_{CL} Capacitor Connection Method

20.4 Usage Note

Although both the F-ZTAT and mask ROM versions fully meet the electrical specifications listed in this manual, there may be differences in the actual values of the electrical characteristics, operating margins, noise margins, and so forth, due to differences in the fabrication process, the on-chip ROM, and the layout patterns.

If the F-ZTAT version is used to carry out system evaluation and testing, therefore, when switching to the mask ROM version the same evaluation and testing procedures should also be conducted on this version.

Appendix A Instruction Set

A.1 Instruction List

Operand Notation

Rd	General register (destination) ^{*1}
Rs	General register (source) ^{*1}
Rn	General register ^{*1}
ERn	General register (32-bit register)
MAC	Multiply-and-accumulate register (32-bit register) ^{*2}
(EAd)	Destination operand
(EAs)	Source operand
EXR	Extended control register
CCR	Condition-code register
N	N (negative) flag in CCR
Z	Z (zero) flag in CCR
V	V (overflow) flag in CCR
C	C (carry) flag in CCR
PC	Program counter
SP	Stack pointer
#IMM	Immediate data
disp	Displacement
+	Add
-	Subtract
×	Multiply
÷	Divide
^	Logical AND
∨	Logical OR
⊕	Logical exclusive OR
→	Transfer from the operand on the left to the operand on the right, or transition from the state on the left to the state on the right
¬	Logical NOT (logical complement)
() < >	Contents of operand
:8/:16/:24/:32	8-, 16-, 24-, or 32-bit length

Notes: 1. General registers include 8-bit registers (R0H to R7H, R0L to R7L), 16-bit registers (R0 to R7, E0 to E7), and 32-bit registers (ER0 to ER7).

2. The MAC register cannot be used in the H8S/2319 Group.

Condition Code Notation

Symbol

↕	Changes according to the result of the instruction
*	Undetermined (no guaranteed value)
0	Always cleared to 0
1	Always set to 1
—	Not affected by execution of the instruction

Table A.1 Instruction Set

(1) Data Transfer Instructions	Mnemonic	Operand Size	Addressing Mode/ Instruction Length (Bytes)						Operation	Condition Code				No. of States ^{*1} Advanced	
			#xx	Rn	@ERn	@(d,ERn)	@-ERn/@ERn+	@aa		@(d,PC)	@aa	I	H		Z
MOV	MOV.B #xx:8,Rd	B 2							#xx:8→Rd8	—	↕	↕	0	—	1
	MOV.B Rs,Rd	B 2							Rs8→Rd8	—	↕	↕	0	—	1
	MOV.B @ERs,Rd	B 2							@ERs→Rd8	—	↕	↕	0	—	2
	MOV.B @(d:16,ERs),Rd	B 4							@(d:16,ERs)→Rd8	—	↕	↕	0	—	3
	MOV.B @(d:32,ERs),Rd	B 8							@(d:32,ERs)→Rd8	—	↕	↕	0	—	5
	MOV.B @ERs+,Rd	B 2							@ERs→Rd8,ERs32+1→ERs32	—	↕	↕	0	—	3
	MOV.B @aa:8,Rd	B 2							@aa:8→Rd8	—	↕	↕	0	—	2
	MOV.B @aa:16,Rd	B 4							@aa:16→Rd8	—	↕	↕	0	—	3
	MOV.B @aa:32,Rd	B 6							@aa:32→Rd8	—	↕	↕	0	—	4
	MOV.B Rs,@ERd	B 2							Rs8→@ERd	—	↕	↕	0	—	2
	MOV.B Rs,@(d:16,ERd)	B 4							Rs8→@(d:16,ERd)	—	↕	↕	0	—	3
	MOV.B Rs,@(d:32,ERd)	B 8							Rs8→@(d:32,ERd)	—	↕	↕	0	—	5
	MOV.B Rs,@-ERd	B 2							ERd32-1→ERd32,Rs8→@ERd	—	↕	↕	0	—	3
	MOV.B Rs,@aa:8	B 2							Rs8→@aa:8	—	↕	↕	0	—	2
	MOV.B Rs,@aa:16	B 4							Rs8→@aa:16	—	↕	↕	0	—	3
	MOV.B Rs,@aa:32	B 6							Rs8→@aa:32	—	↕	↕	0	—	4
MOV.W #xx:16,Rd	W 4							#xx:16→Rd16	—	↕	↕	0	—	2	
MOV.W Rs,Rd	W 2							Rs16→Rd16	—	↕	↕	0	—	1	
MOV.W @ERs,Rd	W 2							@ERs→Rd16	—	↕	↕	0	—	2	

Mnemonic	Operand Size	Addressing Mode/ Instruction Length (Bytes)							Operation	Condition Code							No. of States ^{*1}
		#xx	Rn	@ERN	@(d,ERN)	@ERN/@ERN+	@aa	@(d,PC)		@aa	I	H	N	Z	V	C	
MOV	W			4					@(d:16,ERs)→Rd16	—	—	↕	↕	0	—	3	
	W			8					@(d:32,ERs)→Rd16	—	—	↕	↕	0	—	5	
	W			2			2		@ERs→Rd16,ERs32+2→ERs32	—	—	↕	↕	0	—	3	
	W					4			@aa:16→Rd16	—	—	↕	↕	0	—	3	
	W					6			@aa:32→Rd16	—	—	↕	↕	0	—	4	
	W			2					Rs16→@ERd	—	—	↕	↕	0	—	2	
	W			4					Rs16→@(d:16,ERd)	—	—	↕	↕	0	—	3	
	W			8					Rs16→@(d:32,ERd)	—	—	↕	↕	0	—	5	
	W			2			2		ERd32:2→ERd32,Rs16→@ERd	—	—	↕	↕	0	—	3	
	W					4			Rs16→@aa:16	—	—	↕	↕	0	—	3	
	W					6			Rs16→@aa:32	—	—	↕	↕	0	—	4	
	L	6							#xx:32→ERd32	—	—	↕	↕	0	—	3	
	L		2						ERs32→ERd32	—	—	↕	↕	0	—	1	
	L			4					@ERs→ERd32	—	—	↕	↕	0	—	4	
L				6				@(d:16,ERs)→ERd32	—	—	↕	↕	0	—	5		
L				10				@(d:32,ERs)→ERd32	—	—	↕	↕	0	—	7		
L					4			@ERs→ERd32,ERs32:4→@ERs32	—	—	↕	↕	0	—	5		
L						6		@aa:16→ERd32	—	—	↕	↕	0	—	5		
L						8		@aa:32→ERd32	—	—	↕	↕	0	—	6		

Mnemonic	Operand Size	Addressing Mode/ Instruction Length (Bytes)							Operation	Condition Code					No. of States ^{*1} Advanced	
		#xx	Rn	@ERn	@(d,ERn)	@-ERn/@ERn+	@aa	@(d,PC)		@aa	I	H	N	Z		V
MOV	L		4						ERs32→@ERd	—	—	↕	↕	0	—	4
	L			6					ERs32→@(d:16,ERd)	—	—	↕	↕	0	—	5
	L			10					ERs32→@(d:32,ERd)	—	—	↕	↕	0	—	7
	L			4					ERd32-4→ERd32,ERs32→@ERd	—	—	↕	↕	0	—	5
	L			6					ERs32→@aa:16	—	—	↕	↕	0	—	5
POP	L			8					ERs32→@aa:32	—	—	↕	↕	0	—	6
	W					2			@SP→Rn16,SP+2→SP	—	—	↕	↕	0	—	3
	L					4			@SP→ERn32,SP+4→SP	—	—	↕	↕	0	—	5
PUSH	W					2			SP-2→SP,Rn16→@SP	—	—	↕	↕	0	—	3
	L					4			SP-4→SP,ERn32→@SP	—	—	↕	↕	0	—	5
LDM	L					4			(@SP→ERn32,SP+4→SP) Repeated for each register restored	—	—	—	—	—	—	7/9/11 [1]
STM	L					4			(SP-4→SP,ERn32→@SP) Repeated for each register saved	—	—	—	—	—	—	7/9/11 [1]
MOVFP									Cannot be used in the chip							[2]
MOVTP									Cannot be used in the chip							[2]

(2) Arithmetic Instructions

Mnemonic	Operand Size	Addressing Mode/ Instruction Length (Bytes)								Operation	Condition Code							No. of States*1									
		#xx	Rn	@ERn	@(d,ERn)	@ERn/@ERn+	@aa	@d,PC	@aa		I	I	H	N	Z	V	C		Advanced								
																				B	2	4	6	2	B	2	B
ADD	ADD.B #xx:8,Rd	B	2																Rd8+#xx:8→Rd8	↕	↕	↕	↕	↕	↕	1	
	ADD.B Rs,Rd	B	2																Rd8+Rs8→Rd8	↕	↕	↕	↕	↕	↕	1	
	ADD.W #xx:16,Rd	W	4																Rd16+#xx:16→Rd16	[3]	↕	↕	↕	↕	↕	2	
	ADD.W Rs,Rd	W	2																Rd16+Rs16→Rd16	[3]	↕	↕	↕	↕	↕	1	
	ADD.L #xx:32,ERd	L	6																ERd32+#xx:32→ERd32	[4]	↕	↕	↕	↕	↕	3	
	ADD.L ERs,ERd	L	2																ERd32+ERs32→ERd32	[4]	↕	↕	↕	↕	↕	1	
ADDX	ADDX #xx:8,Rd	B	2																Rd8+#xx:8+C→Rd8	↕	↕	[5]	↕	↕	↕	1	
	ADDX Rs,Rd	B	2																Rd8+Rs8+C→Rd8	↕	↕	[5]	↕	↕	↕	1	
	ADDS #1,ERd	L	2																ERd32+1→ERd32	—	—	—	—	—	—	1	
	ADDS #2,ERd	L	2																ERd32+2→ERd32	—	—	—	—	—	—	1	
	ADDS #4,ERd	L	2																ERd32+4→ERd32	—	—	—	—	—	—	1	
	INC.B Rd	B	2																Rd8+1→Rd8	↕	↕	↕	↕	↕	↕	1	
INC	INC.W #1,Rd	W	2																Rd16+1→Rd16	↕	↕	↕	↕	↕	↕	1	
	INC.W #2,Rd	W	2																Rd16+2→Rd16	↕	↕	↕	↕	↕	↕	1	
	INC.L #1,ERd	L	2																ERd32+1→ERd32	↕	↕	↕	↕	↕	↕	1	
	INC.L #2,ERd	L	2																ERd32+2→ERd32	↕	↕	↕	↕	↕	↕	1	
	DAA Rd	B	2																Rd8 decimal adjust→Rd8	—	*	↕	↕	*	↕	↕	1
	SUB.B Rs,Rd	B	2																Rd8-Rs8→Rd8	↕	↕	↕	↕	↕	↕	1	
SUB	SUB.W #xx:16,Rd	W	4																Rd16-#xx:16→Rd16	—	[3]	↕	↕	↕	↕	↕	2

Mnemonic	Operand Size	Addressing Mode/ Instruction Length (Bytes)							Operation	Condition Code							No. of States ^{*1}
		#xx	Rn	@ERn	@(d,ERn)	@-ERn/@ERn+	@aa	@(d,PC)		@aa	I	H	N	Z	V	C	
DIVXU	B	2							Rd16:Rs8→Rd16 (RdH: remainder, RdL: quotient) (unsigned division)	—	—	[6]	[7]	—	—	12	
	W	2							ERd32:Rs16→ERd32 (Ed: remainder, Rd: quotient) (unsigned division)	—	—	[6]	[7]	—	—	20	
DIVXS	B	4							Rd16:Rs8→Rd16 (RdH: remainder, RdL: quotient) (signed division)	—	—	[8]	[7]	—	—	13	
	W	4							ERd32:Rs16→ERd32 (Ed: remainder, Rd: quotient) (signed division)	—	—	[8]	[7]	—	—	21	
CMP	B	2							Rd8-#xx:8	—	—	↕	↕	↕	↕	1	
	B	2							Rd8-Rs8	—	—	↕	↕	↕	↕	1	
	W	4							Rd16-#xx:16	—	[3]	↕	↕	↕	↕	2	
	W	2							Rd16-Rs16	—	[3]	↕	↕	↕	↕	1	
	L	6							ERd32-#xx:32	—	[4]	↕	↕	↕	↕	3	
	L	2							ERd32-ERs32	—	[4]	↕	↕	↕	↕	1	
NEG	B	2							0-Rd8→Rd8	—	—	↕	↕	↕	↕	1	
	W	2							0-Rd16→Rd16	—	—	↕	↕	↕	↕	1	
	L	2							0-ERd32→ERd32	—	—	↕	↕	↕	↕	1	
EXTU	W	2							0->(<bits 15 to 8> of Rd16)	—	—	0	↕	0	—	1	
	L	2							0->(<bits 31 to 16> of ERd32)	—	—	0	↕	0	—	1	

Mnemonic	Operand Size	Addressing Mode/ Instruction Length (Bytes)							Operation	Condition Code					No. of States ^{*1} Advanced
		#xx	Rn	@ERn	@(d,ERn)	@-ERn/@ERn+	@aa	@(d,PC)		@aa	I	H	N	Z	
EXTS	W	2									↕	↕	0	—	1
EXTS.L ERd	L	2									↕	↕	0	—	1
TAS @ERd ^{*3}	B	4									↕	↕	0	—	4
MAC	MAC @ERn+, @ERm+	Cannot be used in the chip													[2]
CLRMAC	CLRMAC														
LDMAC	LDMAC ERs, MACH														
	LDMAC ERs, MACL														
STMAC	STMAC MACH, ERd														
	STMAC MACL, ERd														

(3) Logical Instructions

Mnemonic	Operand Size	Addressing Mode/ Instruction Length (Bytes)						Operation	Condition Code						No. of States ^{*1}			
		#xx	Rn	@ERn	@d,ERn	@-ERn/@ERn+	@aa		@d,PC	@aa	I	H	N	Z		V	C	Advanced
AND	AND.B #xx:8,Rd	B	2													1		
	AND.B Rs,Rd	B	2													1		
	AND.W #xx:16,Rd	W	4													2		
	AND.W Rs,Rd	W	2													1		
OR	AND.L #xx:32,ERd	L	6													3		
	AND.L ERs,ERd	L	4													2		
	OR.B #xx:8,Rd	B	2													1		
	OR.B Rs,Rd	B	2													1		
	OR.W #xx:16,Rd	W	4													2		
	OR.W Rs,Rd	W	2													1		
	OR.L #xx:32,ERd	L	6													3		
	OR.L ERs,ERd	L	4													2		
XOR	XOR.B #xx:8,Rd	B	2													1		
	XOR.B Rs,Rd	B	2													1		
	XOR.W #xx:16,Rd	W	4													2		
	XOR.W Rs,Rd	W	2													1		
NOT	XOR.L #xx:32,ERd	L	6													3		
	XOR.L ERs,ERd	L	4													2		
	NOT.B Rd	B	2													1		
	NOT.W Rd	W	2													1		
	NOT.L ERd	L	2													1		

Mnemonic	Operand Size	Addressing Mode/ Instruction Length (Bytes)							Operation	Condition Code						No. of States ^{*1} Advanced
		#xx	Rn	@ERn	@(d,ERn)	@-ERn/@ERn+	@aa	@(d,PC)		@@aa	I	H	N	Z	V	
SHLR	B	2								—	—	0	↑	0	↑	1
	B	2						—		—	0	↑	0	↑	1	
	W	2						—		—	0	↑	0	↑	1	
	W	2						—		—	0	↑	0	↑	1	
	L	2						—		—	0	↑	0	↑	1	
ROTXL	B	2							—	—	↑	↑	0	↑	1	
	B	2					—		—	↑	↑	0	↑	1		
	W	2					—		—	↑	↑	0	↑	1		
	W	2					—		—	↑	↑	0	↑	1		
	L	2					—		—	↑	↑	0	↑	1		
ROTXR	B	2							—	—	↑	↑	0	↑	1	
	B	2					—		—	↑	↑	0	↑	1		
	W	2					—		—	↑	↑	0	↑	1		
	W	2					—		—	↑	↑	0	↑	1		
	L	2					—		—	↑	↑	0	↑	1		

Mnemonic	Operand Size	Addressing Mode/ Instruction Length (Bytes)							Operation	Condition Code							No. of States ^{*1} Advanced
		#xx	Rn	@ERn	@(d,ERn)	@-ERn/@ERn+	@aa	@(d,PC)		@aa	I	H	N	Z	V	C	
ROTL	B	2								—	—	↔	↔	0	↔	1	
	B	2								—	—	↔	↔	0	↔	1	
	W	2								—	—	↔	↔	0	↔	1	
	W	2								—	—	↔	↔	0	↔	1	
	L	2								—	—	↔	↔	0	↔	1	
ROTR	B	2							—	—	↔	↔	0	↔	1		
	B	2							—	—	↔	↔	0	↔	1		
	W	2							—	—	↔	↔	0	↔	1		
	W	2							—	—	↔	↔	0	↔	1		
	L	2							—	—	↔	↔	0	↔	1		

(5) Bit-Manipulation Instructions

Mnemonic	Operand Size	Addressing Mode/ Instruction Length (Bytes)						Operation	Condition Code					No. of States*1			
		#xx	Rn	@ERn	@(d,ERn)	@-ERn@ERn+	@aa		@(d,PC)	@aa	I	H	N		Z	V	C
BSET	BSET #xx:3,Rd	B	2														1
	BSET #xx:3,@ERd	B	4														4
	BSET #xx:3,@aa:8	B		4													4
	BSET #xx:3,@aa:16	B		6													5
	BSET #xx:3,@aa:32	B		8													6
	BSET Rn,Rd	B	2														1
	BSET Rn,@ERd	B	4														4
	BSET Rn,@aa:8	B		4													4
BCLR	BSET Rn,@aa:16	B		6													5
	BSET Rn,@aa:32	B		8													6
	BCLR #xx:3,Rd	B	2														1
	BCLR #xx:3,@ERd	B	4														4
	BCLR #xx:3,@aa:8	B		4													4
	BCLR #xx:3,@aa:16	B		6													5
	BCLR #xx:3,@aa:32	B		8													6
	BCLR Rn,Rd	B	2														1
BCLR Rn,@ERd	BCLR Rn,@aa:8	B		4													4
	BCLR Rn,@aa:16	B		6													4
	BCLR Rn,@aa:32	B		8													5
	BCLR Rn,@aa:16	B		6													5
	BCLR Rn,@aa:32	B		8													6

Mnemonic	Operand Size	Addressing Mode/ Instruction Length (Bytes)							Operation	Condition Code					No. of States ^{*1} Advanced		
		#xx	Rn	@ERn	@d,ERn	@-ERn/@ERn+	@aa	@d,PC		@aa	I	H	N	Z		V	C
BCLR	B								(Rn8 of @aa:32) ← 0	—	—	—	—	—	6		
BNOT	B								(#xx:3 of Rd8) ← [–] (#xx:3 of Rd8)	—	—	—	—	—	1		
	B			4					(#xx:3 of @ERd) ← [–] (#xx:3 of @ERd)	—	—	—	—	—	4		
BNOT #xx:3,@aa:8	B							4	(#xx:3 of @aa:8) ← [–] (#xx:3 of @aa:8)	—	—	—	—	—	4		
	B							6	(#xx:3 of @aa:16) ← [–] (#xx:3 of @aa:16)	—	—	—	—	—	5		
BNOT #xx:3,@aa:32	B							8	(#xx:3 of @aa:32) ← [–] (#xx:3 of @aa:32)	—	—	—	—	—	6		
	B								(Rn8 of Rd8) ← [–] (Rn8 of Rd8)	—	—	—	—	—	1		
BNOT Rn,Rd	B		2						(Rn8 of @ERd) ← [–] (Rn8 of @ERd)	—	—	—	—	—	4		
	B			4					(Rn8 of @aa:8) ← [–] (Rn8 of @aa:8)	—	—	—	—	—	4		
	B							6	(Rn8 of @aa:16) ← [–] (Rn8 of @aa:16)	—	—	—	—	—	5		
	B							8	(Rn8 of @aa:32) ← [–] (Rn8 of @aa:32)	—	—	—	—	—	6		
BTST	B								(Rn8 of @aa:32) ← [–] (Rn8 of @aa:32)	—	—	—	—	—	6		
	B								(Rn8 of @aa:32) ← [–] (Rn8 of @aa:32)	—	—	—	—	—	1		
	B			4					(#xx:3 of Rd8) → Z	—	—	—	↑	—	3		
	B							4	(#xx:3 of @ERd) → Z	—	—	—	—	↑	3		
BTST #xx:3,@aa:8	B							4	(#xx:3 of @aa:8) → Z	—	—	—	—	—	3		
	B							6	(#xx:3 of @aa:16) → Z	—	—	—	—	—	4		

Mnemonic	Operand Size	Addressing Mode/ Instruction Length (Bytes)						Operation	Condition Code						No. of States ^{*1}
		#xx	Rn	@ERn	@(d,ERn)	@-ERn/@ERn+	@aa		@(d,PC)	@aa	I	H	N	Z	
BTST	B					8		— (#xx:3 of @aa:32)→Z	—	—	—	↓	—	—	5
	B	2						— (Rn8 of Rd8)→Z	—	—	—	↓	—	—	1
	B		4					— (Rn8 of @ERd)→Z	—	—	—	↓	—	—	3
	B			4				— (Rn8 of @aa:8)→Z	—	—	—	↓	—	—	3
	B				6			— (Rn8 of @aa:16)→Z	—	—	—	↓	—	—	4
BLD	B					8		— (Rn8 of @aa:32)→Z	—	—	—	↓	—	—	5
	B	2						(#xx:3 of Rd8)→C	—	—	—	—	—	—	1
	B		4					(#xx:3 of @ERd)→C	—	—	—	—	—	—	3
	B			4				(#xx:3 of @aa:8)→C	—	—	—	—	—	—	3
	B				6			(#xx:3 of @aa:16)→C	—	—	—	—	—	—	4
BILD	B					8		(#xx:3 of @aa:32)→C	—	—	—	—	—	—	5
	B	2						— (#xx:3 of Rd8)→C	—	—	—	—	—	—	1
	B		4					— (#xx:3 of @ERd)→C	—	—	—	—	—	—	3
	B			4				— (#xx:3 of @aa:8)→C	—	—	—	—	—	—	3
	B				6			— (#xx:3 of @aa:16)→C	—	—	—	—	—	—	4
BST	B					8		(#xx:3 of @aa:32)→C	—	—	—	—	—	—	5
	B	2						C→(#xx:3 of Rd8)	—	—	—	—	—	—	1
	B		4					C→(#xx:3 of @ERd)	—	—	—	—	—	—	4
	B			4				C→(#xx:3 of @aa:8)	—	—	—	—	—	—	4
	B								—	—	—	—	—	—	4

Mnemonic	Operand Size	Addressing Mode/ Instruction Length (Bytes)							Operation	Condition Code					No. of States ^{*1}		
		#xx	Rn	@ERn	@(d,ERn)	@-ERn/@ERn+	@aa	@(d,PC)		@aa	I	H	N	Z		V	C
BOR	B							4							↓	Advanced	3
	B							6							↓		4
	B							8							↓		5
BIOR	B	2													↓		1
	B	4													↓		3
	B							4							↓		3
	B							6							↓		4
	B							8							↓		5
BXOR	B	2													↓		1
	B	4													↓		3
	B							4							↓		3
	B							6							↓		4
	B							8							↓		5
BIXOR	B	2													↓		1
	B	4													↓		3
	B							4							↓		3
	B							6							↓		4
	B							8							↓		5

(6) Branch Instructions

Mnemonic	Operand Size	Addressing Mode/ Instruction Length (Bytes)								Operation	Branching Condition	Condition Code				No. of States ^{*1}			
		#xx	Rn	@ERn	@d,ERn	@ERn/@ERn+	@aa	@d,PC	@aa			I	I	H	N	Z	V	C	Advanced
Bcc	—										Always	—	—	—	—	2			
BRA d:8(BT d:8)	—										if condition is true then PC←PC+d else next;	—	—	—	—	3			
BRA d:16(BT d:16)	—											—	—	—	—	3			
BRN d:8(BF d:8)	—										Never	—	—	—	—	2			
BRN d:16(BF d:16)	—											—	—	—	—	3			
BHI d:8	—										C∨Z=0	—	—	—	—	2			
BHI d:16	—											—	—	—	—	3			
BLS d:8	—										C∨Z=1	—	—	—	—	2			
BLS d:16	—											—	—	—	—	3			
BCC d:8(BHS d:8)	—										C=0	—	—	—	—	2			
BCC d:16(BHS d:16)	—											—	—	—	—	3			
BCS d:8(BLO d:8)	—										C=1	—	—	—	—	2			
BCS d:16(BLO d:16)	—											—	—	—	—	3			
BNE d:8	—										Z=0	—	—	—	—	2			
BNE d:16	—											—	—	—	—	3			
BEQ d:8	—										Z=1	—	—	—	—	2			
BEQ d:16	—											—	—	—	—	3			
BVC d:8	—										V=0	—	—	—	—	2			
BVC d:16	—											—	—	—	—	3			

Mnemonic	Operand Size	Addressing Mode/ Instruction Length (Bytes)							Operation	Condition Code					No. of States ^{*1}	
		#xx	Rn	@ERn	@(d,ERn)	@-ERn/@ERn+	@aa	@(d,PC)		@aa	I	H	N	Z		V
Bcc										V=1	—	—	—	—	—	2
BVS d:8								2			—	—	—	—	—	3
BVS d:16								4			—	—	—	—	—	3
BPL d:8								2		N=0	—	—	—	—	—	2
BPL d:16								4			—	—	—	—	—	3
BMI d:8								2			—	—	—	—	—	2
BMI d:16								4			—	—	—	—	—	3
BGE d:8								2		N \oplus V=0	—	—	—	—	—	2
BGE d:16								4			—	—	—	—	—	3
BLT d:8								2		N \oplus V=1	—	—	—	—	—	2
BLT d:16								4			—	—	—	—	—	3
BGT d:8								2		Z \vee (N \oplus V)=0	—	—	—	—	—	2
BGT d:16								4			—	—	—	—	—	3
BLE d:8								2		Z \vee (N \oplus V)=1	—	—	—	—	—	2
BLE d:16								4			—	—	—	—	—	3

Mnemonic	Operand Size	Addressing Mode/ Instruction Length (Bytes)							Operation	Condition Code					No. of States ^{*1} Advanced	
		#xx	Rn	@ERn	@(d,ERn)	@-ERn/@ERn+	@aa	@(d,PC)		@aa	I	H	N	Z		V
JMP	JMP @ERn	—	2	—	—	—	—	—	PC←ERn	—	—	—	—	—	—	2
	JMP @aa:24	—	—	4	—	—	—	—	PC←aa:24	—	—	—	—	—	—	3
	JMP @aa:8	—	—	—	—	2	—	—	PC←@aa:8	—	—	—	—	—	—	5
BSR	BSR d:8	—	—	—	—	2	—	—	PC→@-SP,PC←PC+d:8	—	—	—	—	—	—	4
	BSR d:16	—	—	—	—	4	—	—	PC→@-SP,PC←PC+d:16	—	—	—	—	—	—	5
JSR	JSR @ERn	—	2	—	—	—	—	—	PC→@-SP,PC←ERn	—	—	—	—	—	—	4
	JSR @aa:24	—	—	4	—	—	—	—	PC→@-SP,PC←aa:24	—	—	—	—	—	—	5
	JSR @aa:8	—	—	—	—	2	—	—	PC→@-SP,PC←@aa:8	—	—	—	—	—	—	6
RTS	RTS	—	—	—	—	—	—	—	PC←@SP+	—	—	—	—	—	—	5

(7) System Control Instructions

Mnemonic	Operand Size	Addressing Mode/ Instruction Length (Bytes)						Operation	Condition Code					No. of States ^{*1} Advanced	
		Rn #xx	@ERn @ERn	@(d,ERn) @-ERn/@ERn+	@aa @(d,PC)	@aa @aa	I		I	H	N	Z	V		C
TRAPA	—							PC→@-SP,CCR→@-SP, EXR→@-SP,<vector>→PC	1	—	—	—	—	—	8 [9]
RTE	—							EXR←@SP+,CCR←@SP+, PC←@SP+	↑	↑	↑	↑	↑	↑	5 [9]
SLEEP	—							Transition to power-down state	—	—	—	—	—	—	2
LDC	B 2							#xx:8→CCR	↑	↑	↑	↑	↑	↑	1
	B 4							#xx:8→EXR	—	—	—	—	—	—	2
	B	2						Rs8→CCR	↑	↑	↑	↑	↑	↑	1
	B	2						Rs8→EXR	—	—	—	—	—	—	1
	W	4						@ERS→CCR	↑	↑	↑	↑	↑	↑	3
	W	4						@ERS→EXR	—	—	—	—	—	—	3
	W	6						@(d:16,ERS)→CCR	↑	↑	↑	↑	↑	↑	4
	W	6						@(d:16,ERS)→EXR	—	—	—	—	—	—	4
	W	10						@(d:32,ERS)→CCR	↑	↑	↑	↑	↑	↑	6
	W	10						@(d:32,ERS)→EXR	—	—	—	—	—	—	6
	W	4						@ERS→CCR,ERS32+2→ERS32	↑	↑	↑	↑	↑	↑	4
	W	4						@ERS→EXR,E,RS32+2→ERS32	—	—	—	—	—	—	4
	W	6						@aa:16→CCR	↑	↑	↑	↑	↑	↑	4
	W	6						@aa:16→EXR	—	—	—	—	—	—	4
	W	8						@aa:32→CCR	↑	↑	↑	↑	↑	↑	5
	W	8						@aa:32→EXR	—	—	—	—	—	—	5

Mnemonic	Operand Size	Addressing Mode/ Instruction Length (Bytes)							Operation	Condition Code					No. of States*1 Advanced			
		#xx	F	@ERn	@(d,ERn)	@-ERn/@ERn+	@aa	@(d,PC)		@aa	I	H	N	Z		V	C	
STC	STC CCR,Rd	B	2															1
	STC EXR,Rd	B	2															1
	STC CCR,@ERd	W		4														3
	STC EXR,@ERd	W		4														3
	STC CCR,@(d:16,ERd)	W			6													4
	STC EXR,@(d:16,ERd)	W			6													4
	STC CCR,@(d:32,ERd)	W			10													6
	STC EXR,@(d:32,ERd)	W			10													6
	STC CCR,@-ERd	W			4													4
	STC EXR,@-ERd	W			4													4
ANDC	ANDC CCR,@aa:16	W			6													4
	ANDC EXR,@aa:16	W			6													4
	ANDC CCR,@aa:32	W			8													5
	ANDC EXR,@aa:32	W			8													5
	ANDC #xx:8,CCR	B	2															1
ORC	ANDC #xx:8,EXR	B	4															2
	ORC #xx:8,CCR	B	2															1
	ORC #xx:8,EXR	B	4															2
XORC	XORC #xx:8,CCR	B	2															1
	XORC #xx:8,EXR	B	4															2
NOP	NOP	—																1

(8) Block Transfer Instructions

Mnemonic	Operand Size	Addressing Mode/ Instruction Length (Bytes)							Operation	Condition Code				No. of States ^{*1}	
		#xx	Rn	@ERn	@(d,ERn)	@-ERn/ERn+	@aa	@(d,PC)		@aa	I	H	N		Z
EEPMOV	—								4	if R4L≠0 Repeat @ER5→@ER6 ER5+1→ER5 ER6+1→ER6 R4L-1→R4L Until R4L=0 else next;	—	—	—	—	4+2n ^{*2}
EEPMOV.W	—								4	if R4≠0 Repeat @ER5→@ER6 ER5+1→ER5 ER6+1→ER6 R4-1→R4 Until R4=0 else next;	—	—	—	—	4+2n ^{*2}

Notes: 1. The number of states is the number of states required for execution when the instruction and its operands are located in on-chip memory.

2. n is the initial value of R4L or R4.

3. Only register ER0, ER1, ER4, or ER5 should be used when using the TAS instruction.

[1] Seven states for saving or restoring two registers, nine states for three registers, or eleven states for four registers.

[2] Cannot be used in the chip.

[3] Set to 1 when a carry or borrow occurs at bit 11; otherwise cleared to 0.

[4] Set to 1 when a carry or borrow occurs at bit 27; otherwise cleared to 0.

[5] Retains its previous value when the result is zero; otherwise cleared to 0.

[6] Set to 1 when the divisor is negative; otherwise cleared to 0.

[7] Set to 1 when the divisor is zero; otherwise cleared to 0.

[8] Set to 1 when the quotient is negative; otherwise cleared to 0.

[9] One additional state is required for execution when EXR is valid.

A.2 Instruction Codes

Table A.2 shows the instruction codes.

Table A.2 Instruction Codes

Instruction	Mnemonic	Size	Instruction Format																	
			1st byte	2nd byte	3rd byte	4th byte	5th byte	6th byte	7th byte	8th byte	9th byte	10th byte								
ADD	ADD.B #xx:8,Rd	B	8	rd	IMM															
	ADD.B Rs,Rd	B	0	8	rs	rd														
	ADD.W #xx:16,Rd	W	7	9	1	rd	IMM													
	ADD.W Rs,Rd	W	0	9	rs	rd														
	ADD.L #xx:32,ERd	L	7	A	1	0:erd		IMM												
	ADD.L ERs,ERd	L	0	A	1	ers:0:erd														
ADDS	ADDS #1,ERd	L	0	B	0	0:erd														
	ADDS #2,ERd	L	0	B	8	0:erd														
	ADDS #4,ERd	L	0	B	9	0:erd														
	ADDS #x:8,Rd	L	9	rd	IMM															
	ADDS Rs,Rd	B	0	E	rs	rd														
	ADDS #xx:8,Rd	B	E	rd	IMM															
AND	AND.B Rs,Rd	B	1	6	rs	rd														
	AND.W #xx:16,Rd	W	7	9	6	rd	IMM													
	AND.W Rs,Rd	W	6	6	rs	rd														
	AND.L #xx:32,ERd	L	7	A	6	0:erd		IMM												
	AND.L ERs,ERd	L	0	1	F	0	6	6	0:ers:0:erd											
	ANDC #xx:8,CCR	B	0	6	IMM															
BAND	ANDC #xx:8,EXR	B	0	1	4	1	0	6	IMM											
	BAND #xx:3,Rd	B	7	6	0:IMM:	rd														
	BAND #xx:3,@ERd	B	7	C	0:erd	0	7	6	0:IMM:	0										
	BAND #xx:3,@aa:8	B	7	E	abs	7	6	0:IMM:	0											
	BAND #xx:3,@aa:16	B	6	A	1	0	abs	7	6	0:IMM:	0									
	BAND #xx:3,@aa:32	B	6	A	3	0	abs	7	6	0:IMM:	0									
Bcc	BRA d:8 (BT d:8)	—	4	0	disp															
	BRA d:16 (BT d:16)	—	5	8	0	0	disp													
	BRN d:8 (BF d:8)	—	4	1	disp															
	BRN d:16 (BF d:16)	—	5	8	1	0	disp													

Instruction	Mnemonic	Size	Instruction Format																	
			1st byte	2nd byte	3rd byte	4th byte	5th byte	6th byte	7th byte	8th byte	9th byte	10th byte								
Bcc	BHI d:8	—	4	2	disp															
	BHI d:16	—	5	8	2	0	disp													
	BLS d:8	—	4	3	disp															
	BLS d:16	—	5	8	3	0	disp													
	BCC d:8 (BHS d:8)	—	4	4	disp															
	BCC d:16 (BHS d:16)	—	5	8	4	0	disp													
	BCS d:8 (BLO d:8)	—	4	5	disp															
	BCS d:16 (BLO d:16)	—	5	8	5	0	disp													
	BNE d:8	—	4	6	disp															
	BNE d:16	—	5	8	6	0	disp													
	BEQ d:8	—	4	7	disp															
	BEQ d:16	—	5	8	7	0	disp													
	BVC d:8	—	4	8	disp															
	BVC d:16	—	5	8	8	0	disp													
	BVS d:8	—	4	9	disp															
	BVS d:16	—	5	8	9	0	disp													
	BPL d:8	—	4	A	disp															
	BPL d:16	—	5	8	A	0	disp													
	BMI d:8	—	4	B	disp															
	BMI d:16	—	5	8	B	0	disp													
BGE d:8	—	4	C	disp																
BGE d:16	—	5	8	C	0	disp														
BLT d:8	—	4	D	disp																
BLT d:16	—	5	8	D	0	disp														
BGT d:8	—	4	E	disp																
BGT d:16	—	5	8	E	0	disp														
BLE d:8	—	4	F	disp																
BLE d:16	—	5	8	F	0	disp														

Instruction	Mnemonic	Size	Instruction Format															
			1st byte	2nd byte	3rd byte	4th byte	5th byte	6th byte	7th byte	8th byte	9th byte	10th byte						
BCLR	BCLR #xx:3,Rd	B	7	2	0:IMM; rd													
	BCLR #xx:3,@ERd	B	7	D	0:erd; 0	7	2	0:IMM; 0										
	BCLR #xx:3,@aa:8	B	7	F	abs	7	2	0:IMM; 0										
	BCLR #xx:3,@aa:16	B	6	A	1	8	abs		7	2	0:IMM; 0							
	BCLR #xx:3,@aa:32	B	6	A	3	8	abs											
	BCLR Rn,Rd	B	6	2	rn	rd												
BIAND	BCLR Rn,@ERd	B	7	D	0:erd; 0	6	2	rn	0									
	BCLR Rn,@aa:8	B	7	F	abs	6	2	rn	0									
	BCLR Rn,@aa:16	B	6	A	1	8	abs		6	2	rn	0						
	BCLR Rn,@aa:32	B	6	A	3	8	abs											
	BIAND #xx:3,Rd	B	7	6	1:IMM; rd													
	BIAND #xx:3,@ERd	B	7	C	0:erd; 0	7	6	1:IMM; 0										
BILD	BIAND #xx:3,@aa:8	B	7	E	abs	7	6	1:IMM; 0										
	BIAND #xx:3,@aa:16	B	6	A	1	0	abs		7	6	1:IMM; 0							
	BIAND #xx:3,@aa:32	B	6	A	3	0	abs											
	BILD #xx:3,Rd	B	7	7	1:IMM; rd													
	BILD #xx:3,@ERd	B	7	C	0:erd; 0	7	7	1:IMM; 0										
	BILD #xx:3,@aa:8	B	7	E	abs	7	7	1:IMM; 0										
BIOR	BILD #xx:3,@aa:16	B	6	A	1	0	abs		7	7	1:IMM; 0							
	BILD #xx:3,@aa:32	B	6	A	3	0	abs											
	BIOR #xx:3,Rd	B	7	4	1:IMM; rd													
	BIOR #x:3,@ERd	B	7	C	0:erd; 0	7	4	1:IMM; 0										
	BIOR #x:3,@aa:8	B	7	E	abs	7	4	1:IMM; 0										
	BIOR #x:3,@aa:16	B	6	A	1	0	abs		7	4	1:IMM; 0							

Instruction	Mnemonic	Size	Instruction Format																	
			1st byte	2nd byte	3rd byte	4th byte	5th byte	6th byte	7th byte	8th byte	9th byte	10th byte								
BIST	BIST #xx:3,Rd	B	6	7	1:IMM; rd															
	BIST #xx:3,@ERd	B	7	D	0:erd; 0	6	7	1:IMM; 0												
	BIST #xx:3,@aa:8	B	7	F	abs	6	7	1:IMM; 0												
	BIST #xx:3,@aa:16	B	6	A	1	8	abs	6	7	1:IMM; 0										
	BIST #xx:3,@aa:32	B	6	A	3	8	abs	abs												
BIXOR	BIXOR #xx:3,Rd	B	7	5	1:IMM; rd															
	BIXOR #xx:3,@ERd	B	7	C	0:erd; 0	7	5	1:IMM; 0												
	BIXOR #xx:3,@aa:8	B	7	E	abs	7	5	1:IMM; 0												
	BIXOR #xx:3,@aa:16	B	6	A	1	0	abs	7	5	1:IMM; 0										
	BIXOR #xx:3,@aa:32	B	6	A	3	0	abs	abs												
BLD	BLD #xx:3,Rd	B	7	7	0:IMM; rd															
	BLD #xx:3,@ERd	B	7	C	0:erd; 0	7	7	0:IMM; 0												
	BLD #xx:3,@aa:8	B	7	E	abs	7	7	0:IMM; 0												
	BLD #xx:3,@aa:16	B	6	A	1	0	abs	7	7	0:IMM; 0										
	BLD #xx:3,@aa:32	B	6	A	3	0	abs	abs												
BNOT	BNOT #xx:3,Rd	B	7	1	0:IMM; rd															
	BNOT #xx:3,@ERd	B	7	D	0:erd; 0	7	1	0:IMM; 0												
	BNOT #xx:3,@aa:8	B	7	F	abs	7	1	0:IMM; 0												
	BNOT #xx:3,@aa:16	B	6	A	1	8	abs	7	1	0:IMM; 0										
	BNOT #xx:3,@aa:32	B	6	A	3	8	abs	abs												
BNOT Rn,Rd	BNOT Rn,Rd	B	6	1	rn	rd														
	BNOT Rn,@ERd	B	7	D	0:erd; 0	6	1	rn	0											
	BNOT Rn,@aa:8	B	7	F	abs	6	1	rn	0											
	BNOT Rn,@aa:16	B	6	A	1	8	abs	6	1	rn	0									
	BNOT Rn,@aa:32	B	6	A	3	8	abs	abs												

Instruc- tion	Mnemonic	Size	Instruction Format																		
			1st byte	2nd byte	3rd byte	4th byte	5th byte	6th byte	7th byte	8th byte	9th byte	10th byte									
BOR	BOR #xx:3,Rd	B	7	4	0:IMM; rd																
	BOR #xx:3,@ERd	B	7	C	0:erd; 0	7	4	0:IMM; 0													
	BOR #xx:3,@aa:8	B	7	E	abs	7	4	0:IMM; 0													
	BOR #xx:3,@aa:16	B	6	A	1	0	abs		7	4	0:IMM; 0										
	BOR #xx:3,@aa:32	B	6	A	3	0	abs					7	4	0:IMM; 0							
BSET	BSET #xx:3,Rd	B	7	0	0:IMM; rd																
	BSET #xx:3,@ERd	B	7	D	0:erd; 0	7	0	0:IMM; 0													
	BSET #xx:3,@aa:8	B	7	F	abs	7	0	0:IMM; 0													
	BSET #xx:3,@aa:16	B	6	A	1	8	abs		7	0	0:IMM; 0										
	BSET #xx:3,@aa:32	B	6	A	3	8	abs					7	0	0:IMM; 0							
	BSET Rn,Rd	B	6	0	rn; rd																
	BSET Rn,@ERd	B	7	D	0:erd; 0	6	0	rn; 0													
	BSET Rn,@aa:8	B	7	F	abs	6	0	rn; 0													
	BSET Rn,@aa:16	B	6	A	1	8	abs		6	0	rn; 0										
	BSET Rn,@aa:32	B	6	A	3	8	abs					6	0	rn; 0							
BSR	BSR d:8	—	5	5	disp																
	BSR d:16	—	5	C	0	0	disp														
BST	BST #xx:3,Rd	B	6	7	0:IMM; rd																
	BST #xx:3,@ERd	B	7	D	0:erd; 0	6	7	0:IMM; 0													
	BST #xx:3,@aa:8	B	7	F	abs	6	7	0:IMM; 0													
	BST #xx:3,@aa:16	B	6	A	1	8	abs		6	7	0:IMM; 0										
	BST #xx:3,@aa:32	B	6	A	3	8	abs					6	7	0:IMM; 0							
	BTST #xx:3,Rd	B	7	3	0:IMM; rd																
BTST	BTST #xx:3,@ERd	B	7	C	0:erd; 0	7	3	0:IMM; 0													
	BTST #xx:3,@aa:8	B	7	E	abs	7	3	0:IMM; 0													
	BTST #xx:3,@aa:16	B	6	A	1	0	abs		7	3	0:IMM; 0										
	BTST #xx:3,@aa:32	B	6	A	3	0	abs					7	3	0:IMM; 0							
	BTST Rn,Rd	B	6	3	rn; rd																
	BTST Rn,@ERd	B	7	C	0:erd; 0	6	3	rn; 0													

Instruction	Mnemonic	Size	Instruction Format																	
			1st byte	2nd byte	3rd byte	4th byte	5th byte	6th byte	7th byte	8th byte	9th byte	10th byte								
BTST	BTST Rn,@aa:8	B	7	E	abs	6	3	m	0											
	BTST Rn,@aa:16	B	6	A	1	0	abs			6	3	rn	0							
	BTST Rn,@aa:32	B	6	A	3	0	abs							6	3	rn	0			
BXOR	BXOR #xx:3,Rd	B	7	5	0;IMM;rd															
	BXOR #xx:3,@ERd	B	7	C	0;erd	7	5	0;IMM;0												
	BXOR #xx:3,@aa:8	B	7	E	abs	7	5	0;IMM;0												
	BXOR #xx:3,@aa:16	B	6	A	1	0	abs			7	5	0;IMM;0								
	BXOR #xx:3,@aa:32	B	6	A	3	0	abs													
CLRMAC	CLRMAC	—	Cannot be used in the chip																	
CMP	CMP.B #xx:8,Rd	B	A	rd	IMM															
	CMP.B Rs,Rd	B	1	C	rs	rd														
	CMP.W #xx:16,Rd	W	7	9	2	rd	IMM													
	CMP.W Rs,Rd	W	1	D	rs	rd														
	CMP.L #xx:32,ERd	L	7	A	2	0;erd														
	CMP.L ERs,ERd	L	1	F	1;ers	0;erd														
DAA	DAA Rd	B	0	F	0	rd														
DAS	DAS Rd	B	1	F	0	rd														
DEC	DEC.B Rd	B	1	A	0	rd														
	DEC.W #1,Rd	W	1	B	5	rd														
	DEC.W #2,Rd	W	1	B	D	rd														
	DEC.L #1,ERd	L	1	B	7	0;erd														
	DEC.L #2,ERd	L	1	B	F	0;erd														
DIVXS	DIVXS.B Rs,Rd	B	0	1	D	0	5	1	rs	rd										
	DIVXS.W Rs,ERd	W	0	1	D	0	5	3	rs	0;erd										
DIVXU	DIVXU.B Rs,Rd	B	5	1	rs	rd														
	DIVXU.W Rs,ERd	W	5	3	rs	0;erd														
EEPMOV	EEPMOV.B	—	7	B	5	C	5	9	8	F										
	EEPMOV.W	—	7	B	D	4	5	9	8	F										

Instruction	Mnemonic	Size	Instruction Format																			
			1st byte	2nd byte	3rd byte	4th byte	5th byte	6th byte	7th byte	8th byte	9th byte	10th byte										
EXTS	EXTS.W Rd	W	1	7	D	rd																
	EXTS.L ERd	L	1	7	F	0:erd																
EXTU	EXTU.W Rd	W	1	7	5	rd																
	EXTU.L ERd	L	1	7	7	0:erd																
INC	INC.B Rd	B	0	A	0	rd																
	INC.W #1,Rd	W	0	B	5	rd																
	INC.W #2,Rd	W	0	B	D	rd																
	INC.L #1,ERd	L	0	B	7	0:erd																
	INC.L #2,ERd	L	0	B	F	0:erd																
JMP	JMP @ERn	—	5	9	0:ern	0																
	JMP @aa:24	—	5	A		abs																
JSR	JMP @aa:8	—	5	B	abs																	
	JSR @ERn	—	5	D	0:ern	0																
	JSR @aa:24	—	5	E		abs																
	JSR @aa:8	—	5	F	abs																	
	LDC #xx:8,CCR	B	0	7	IMM																	
LDC	LDC #xx:8,EXR	B	0	1	4	1	0	7	IMM													
	LDC Rs,CCR	B	0	3	0	rs																
	LDC Rs,EXR	B	0	3	1	rs																
	LDC @ERs,CCR	W	0	1	4	0	6	9	0:ers	0												
	LDC @ERs,EXR	W	0	1	4	1	6	9	0:ers	0												
	LDC @(d:16,ERs),CCR	W	0	1	4	0	6	F	0:ers	0	disp											
	LDC @(d:16,ERs),EXR	W	0	1	4	1	6	F	0:ers	0	disp											
	LDC @(d:32,ERs),CCR	W	0	1	4	0	7	8	0:ers	0	6	B	2	0	disp							
	LDC @(d:32,ERs),EXR	W	0	1	4	1	7	8	0:ers	0	6	B	2	0	disp							
	LDC @ERs+,CCR	W	0	1	4	0	6	D	0:ers	0												
	LDC @ERs+,EXR	W	0	1	4	1	6	D	0:ers	0												
	LDC @aa:16,CCR	W	0	1	4	0	6	B	0	0	abs											
LDC @aa:16,EXR	W	0	1	4	1	6	B	0	0	abs												

Instruction	Mnemonic	Size	Instruction Format																	
			1st byte	2nd byte	3rd byte	4th byte	5th byte	6th byte	7th byte	8th byte	9th byte	10th byte								
LDC	LDC @aa:32,CCR	W	0 1	4 0	6 B	2 0														
	LDC @aa:32,EXR	W	0 1	4 1	6 B	2 0														
LDM	LDM.L @SP+, (ERn-ERn+1)	L	0 1	1 0	6 D	7 0:erm+1														
	LDM.L @SP+, (ERn-ERn+2)	L	0 1	2 0	6 D	7 0:erm+2														
	LDM.L @SP+, (ERn-ERn+3)	L	0 1	3 0	6 D	7 0:erm+3														
LDMAC	LDMAC ERs,MACH	L	Cannot be used in the chip																	
	LDMAC ERs,MACL	L																		
MAC	MAC @ERn+,@ERm+	—																		
MOV	MOV.B #xx:8,Rd	B	F rd	IMM																
	MOV.B Rs,Rd	B	0 C	rs rd																
	MOV.B @ERS,Rd	B	6 8	0:ers rd																
	MOV.B @(d:16,ERS),Rd	B	6 E	0:ers rd			disp													
	MOV.B @(d:32,ERS),Rd	B	7 8	0:ers 0	6 A	2 rd														
	MOV.B @ERS+,Rd	B	6 C	0:ers rd																
	MOV.B @aa:8,Rd	B	2 rd	abs																
	MOV.B @aa:16,Rd	B	6 A	0 rd			abs													
	MOV.B @aa:32,Rd	B	6 A	2 rd			abs													
	MOV.B Rs,@ERd	B	6 8	1:erd rs																
	MOV.B Rs,@(d:16,ERd)	B	6 E	1:erd rs			disp													
	MOV.B Rs,@(d:32,ERd)	B	7 8	0:erd 0	6 A	A rs														
	MOV.B Rs,@-ERd	B	6 C	1:erd rs																
	MOV.B Rs,@aa:8	B	3 rs	abs																
	MOV.B Rs,@aa:16	B	6 A	8 rs			abs													
	MOV.B Rs,@aa:32	B	6 A	A rs			abs													
	MOV.W #xx:16,Rd	W	7 9	0 rd			IMM													
MOV.W Rs,Rd	W	0 D	rs rd																	
MOV.W @ERS,Rd	W	6 9	0:ers rd																	
MOV.W @(d:16,ERS),Rd	W	6 F	0:ers rd			disp														
MOV.W @(d:32,ERS),Rd	W	7 8	0:ers 0	6 B	2 rd															

Instruction	Mnemonic	Size	Instruction Format																	
			1st byte	2nd byte	3rd byte	4th byte	5th byte	6th byte	7th byte	8th byte	9th byte	10th byte								
MOV	MOV.W @ERs+, Rd	W	6	D	0:ers	rd														
	MOV.W @aa:16, Rd	W	6	B	0	rd	abs													
	MOV.W @aa:32, Rd	W	6	B	2	rd	abs													
	MOV.W Rs, @ERd	W	6	9	1:erd	rs														
	MOV.W Rs, @(d:16, ERd)	W	6	F	1:erd	rs	disp													
	MOV.W Rs, @(d:32, ERd)	W	7	8	0:erd	0	6	B	A	rs		disp								
	MOV.W Rs, @-ERd	W	6	D	1:erd	rs														
	MOV.W Rs, @aa:16	W	6	B	8	rs	abs													
	MOV.W Rs, @aa:32	W	6	B	A	rs	abs													
	MOV.L #xx:32, Rd	L	7	A	0	0:erd														
	MOV.L ERs, ERd	L	0	F	1:ers	0:erd														
	MOV.L @ERs, ERd	L	0	1	0	0	6	9	0:ers	0:erd										
	MOV.L @(d:16, ERs), ERd	L	0	1	0	0	6	F	0:ers	0:erd	disp									
	MOV.L @(d:32, ERs), ERd	L	0	1	0	0	7	8	0:ers	0	6	B	2	0:erd	disp					
	MOV.L @ERs+, ERd	L	0	1	0	0	6	D	0:ers	0:erd										
	MOV.L @aa:16, ERd	L	0	1	0	0	6	B	0	0:erd	abs									
MOV.L @aa:32, ERd	L	0	1	0	0	6	B	2	0:erd	abs										
MOV.L ERs, @ERd	L	0	1	0	0	6	9	1:erd	0:ers											
MOV.L ERs, @(d:16, ERd)	L	0	1	0	0	6	F	1:erd	0:ers	disp										
MOV.L ERs, @(d:32, ERd) ^{*1}	L	0	1	0	0	7	8	0:erc	0	6	B	A	0:ers	disp						
MOV.L ERs, @-ERd	L	0	1	0	0	6	D	1:erd	0:ers											
MOV.L ERs, @aa:16	L	0	1	0	0	6	B	8	0:ers	abs										
MOV.L ERs, @aa:32	L	0	1	0	0	6	B	A	0:ers	abs										
MOV.FPE @aa:16, Rd	B	Cannot be used in the chip																		
MOV.TPE	MOV.TPE Rs, @aa:16	B																		
MUL.XS	MUL.XS.B Rs, Rd	B	0	1	C	0	5	0	rs	rd										
	MUL.XS.W Rs, ERd	W	0	1	C	0	5	2	rs	0:erd										
MUL.XU	MUL.XU.B Rs, Rd	B	5	0	rs	rd														
	MUL.XU.W Rs, ERd	W	5	2	rs	0:erd														

Instruction	Mnemonic	Size	Instruction Format																	
			1st byte	2nd byte	3rd byte	4th byte	5th byte	6th byte	7th byte	8th byte	9th byte	10th byte								
NEG	NEG.B Rd	B	1 7	8 rd																
	NEG.W Rd	W	1 7	9 rd																
	NEG.L ERd	L	1 7	B 0:erd																
NOP	NOP	—	0 0	0 0																
NOT	NOT.B Rd	B	1 7	0 rd																
	NOT.W Rd	W	1 7	1 rd																
	NOT.L ERd	L	1 7	3 0:erd																
OR	OR.B #xx:8,Rd	B	C rd	IMM																
	OR.B Rs,Rd	B	1 4	rs rd																
	OR.W #xx:16,Rd	W	7 9	4 rd	IMM															
	OR.W Rs,Rd	W	6 4	rs rd																
	OR.L #xx:32,ERd	L	7 A	4 0:erd																
ORC	OR.L ERs,ERd	L	0 1	F 0	6 4	0:ers	0:erd													
	ORC #xx:8,CCR	B	0 4	IMM																
	ORC #xx:8,EXR	B	0 1	4 1	0 4	IMM														
POP	POP.W Rn	W	6 D	7 rn																
	POP.L ERn	L	0 1	0 0	6 D	7 0:ern														
PUSH	PUSH.W Rn	W	6 D	F rn																
	PUSH.L ERn	L	0 1	0 0	6 D	F 0:ern														
ROTL	ROTL.B Rd	B	1 2	8 rd																
	ROTL.B #2, Rd	B	1 2	C rd																
	ROTL.W Rd	W	1 2	9 rd																
	ROTL.W #2, Rd	W	1 2	D rd																
	ROTL.L ERd	L	1 2	B 0:erd																
	ROTL.L #2, ERd	L	1 2	F 0:erd																

Instruc- tion	Mnemonic	Size	Instruction Format																	
			1st byte	2nd byte	3rd byte	4th byte	5th byte	6th byte	7th byte	8th byte	9th byte	10th byte								
ROTR	ROTR.B Rd	B	1	3	8	rd														
	ROTR.B #2, Rd	B	1	3	C	rd														
	ROTR.W Rd	W	1	3	9	rd														
	ROTR.W #2, Rd	W	1	3	D	rd														
	ROTR.L ERd	L	1	3	B	0:erd														
	ROTR.L #2, ERd	L	1	3	F	0:erd														
ROTXL	ROTXL.B Rd	B	1	2	0	rd														
	ROTXL.B #2, Rd	B	1	2	4	rd														
	ROTXL.W Rd	W	1	2	1	rd														
	ROTXL.W #2, Rd	W	1	2	5	rd														
	ROTXL.L ERd	L	1	2	3	0:erd														
	ROTXL.L #2, ERd	L	1	2	7	0:erd														
ROTXR	ROTXR.B Rd	B	1	3	0	rd														
	ROTXR.B #2, Rd	B	1	3	4	rd														
	ROTXR.W Rd	W	1	3	1	rd														
	ROTXR.W #2, Rd	W	1	3	5	rd														
	ROTXR.L ERd	L	1	3	3	0:erd														
	ROTXR.L #2, ERd	L	1	3	7	0:erd														
RTE		—	5	6	7	0														
RTS		—	5	4	7	0														
SHAL	SHAL.B Rd	B	1	0	8	rd														
	SHAL.B #2, Rd	B	1	0	C	rd														
	SHAL.W Rd	W	1	0	9	rd														
	SHAL.W #2, Rd	W	1	0	D	rd														
	SHAL.L ERd	L	1	0	B	0:erd														
	SHAL.L #2, ERd	L	1	0	F	0:erd														

Instruction	Mnemonic	Size	Instruction Format																				
			1st byte	2nd byte	3rd byte	4th byte	5th byte	6th byte	7th byte	8th byte	9th byte	10th byte											
SHAR	SHAR.B Rd	B	1	8	rd																		
	SHAR.B #2, Rd	B	1	1	C	rd																	
	SHAR.W Rd	W	1	1	9	rd																	
	SHAR.W #2, Rd	W	1	1	D	rd																	
	SHAR.L ERd	L	1	1	B	0:erd																	
	SHAR.L #2, ERd	L	1	1	F	0:erd																	
SHLL	SHLL.B Rd	B	1	0	0	rd																	
	SHLL.B #2, Rd	B	1	0	4	rd																	
	SHLL.W Rd	W	1	0	1	rd																	
	SHLL.W #2, Rd	W	1	0	5	rd																	
	SHLL.L ERd	L	1	0	3	0:erd																	
	SHLL.L #2, ERd	L	1	0	7	0:erd																	
SHLR	SHLR.B Rd	B	1	1	0	rd																	
	SHLR.B #2, Rd	B	1	1	4	rd																	
	SHLR.W Rd	W	1	1	1	rd																	
	SHLR.W #2, Rd	W	1	1	5	rd																	
	SHLR.L ERd	L	1	1	3	0:erd																	
	SHLR.L #2, ERd	L	1	1	7	0:erd																	
SLEEP	SLEEP	—	0	1	8	0																	
STC	STC.B CCR,Rd	B	0	2	0	rd																	
	STC.B EXR, Rd	B	0	2	1	rd																	
	STC.W CCR,@ERd	W	0	1	4	0	6	9	1:erd	0													
	STC.W EXR,@ERd	W	0	1	4	1	6	9	1:erd	0													
	STC.W CCR,@(d:16,ERd)	W	0	1	4	0	6	F	1:erd	0													
	STC.W EXR,@(d:16,ERd)	W	0	1	4	1	6	F	1:erd	0													
	STC.W CCR,@(d:32,ERd)	W	0	1	4	0	7	8	0:erd	0	6	B	A	0								disp	
	STC.W EXR,@(d:32,ERd)	W	0	1	4	1	7	8	0:erd	0	6	B	A	0									disp
	STC.W CCR,@-ERd	W	0	1	4	0	6	D	1:erd	0													
STC.W EXR,@-ERd	W	0	1	4	1	6	D	1:erd	0														

Instruction	Mnemonic	Size	Instruction Format												
			1st byte	2nd byte	3rd byte	4th byte	5th byte	6th byte	7th byte	8th byte	9th byte	10th byte			
STC	STC.W CCR,@aa:16	W	0 1	4 0	6 B	8 0	abs								
	STC.W EXR,@aa:16	W	0 1	4 1	6 B	8 0	abs								
	STC.W CCR,@aa:32	W	0 1	4 0	6 B	A 0									
	STC.W EXR,@aa:32	W	0 1	4 1	6 B	A 0									
STM	STM.L(ERn-ERn+1),@SP	L	0 1	1 0	6 D	F 0:ern									
	STM.L(ERn-ERn+2),@SP	L	0 1	2 0	6 D	F 0:ern									
	STM.L(ERn-ERn+3),@SP	L	0 1	3 0	6 D	F 0:ern									
STMAC	STMAC MACH,ERd	L	Cannot be used in the chip												
SUB	STMAC MACL,ERd	L													
	SUB.B Rs,Rd	B	1 8	rs rd											
	SUB.W #xx:16,Rd	W	7 9	3 rd	IMM										
	SUB.W Rs,Rd	W	1 9	rs rd											
	SUB.L #xx:32,ERd	L	7 A	3 0:erd			IMM								
	SUB.L ERs,ERd	L	1 A	1 ers 0:erd											
SUBS	SUBS #1,ERd	L	1 B	0 0:erd											
	SUBS #2,ERd	L	1 B	8 0:erd											
	SUBS #4,ERd	L	1 B	9 0:erd											
	SUBS #xx:8,Rd	B	B rd	IMM											
SUBX	SUBX Rs,Rd	B	1 E	rs rd											
	TAS @ERd*2	B	0 1	E 0	7 B	0:erd C									
TRAPA	TRAPA #x:2	—	5 7	00:IMM: 0											
XOR	XOR.B #xx:8,Rd	B	D rd	IMM											
	XOR.B Rs,Rd	B	1 5	rs rd											
	XOR.W #xx:16,Rd	W	7 9	5 rd	IMM										
	XOR.W Rs,Rd	W	6 5	rs rd											
	XOR.L #xx:32,ERd	L	7 A	5 0:erd			IMM								
XOR.L ERs,ERd	L	0 1	F 0	6 5	0:ers 0:erd										

Instruction	Mnemonic	Size	Instruction Format													
			1st byte	2nd byte	3rd byte	4th byte	5th byte	6th byte	7th byte	8th byte	9th byte	10th byte				
XORC	#xx:8,COR	B	0	5	IMM											
XORC	#xx:8,EXR	B	0	1	4	1	0	5	IMM							

- Notes: 1. Bit 7 of the 4th byte of the MOV.L ERs, @(d:32,ERd) instruction can be either 1 or 0.
 2. Only register ER0, ER1, ER4, or ER5 should be used when using the TAS instruction.

Legend:

IMM: Immediate data (2, 3, 8, 16, or 32 bits)

abs: Absolute address (8, 16, 24, or 32 bits)

disp: Displacement (8, 16, or 32 bits)

rs, rd, rn: Register field (4 bits specifying an 8-bit or 16-bit register. The symbols rs, rd, and rn correspond to operand symbols Rs, Rd, and Rn.)
 ers, erd, ern, erm: Register field (3 bits specifying an address register or 32-bit register. The symbols ers, erd, ern, and erm correspond to operand symbols ERs, ERd, ERn, and ERm.)

The register fields specify general registers as follows.

Address Register		16-Bit Register		8-Bit Register	
Register Field	General Register	Register Field	General Register	Register Field	General Register
000	ER0	0000	R0	0000	R0H
001	ER1	0001	R1	0001	R1H
.
.
111	ER7	0111	R7	0111	R7H
		1000	E0	1000	R0L
		1001	E1	1001	R1L
	
	
	
		1111	E7	1111	R7L

A.3 Operation Code Map

Table A.3 shows the operation code map.

Table A.3 Operation Code Map (1)

Instruction code

1st byte		2nd byte	
AH	AL	BH	BL

Instruction when most significant bit of BH is 0.

Instruction when most significant bit of BH is 1.

AL/AH	0	1	2	3	4	5	6	7	8	9	A	B	C	D	E	F
0	NOP	STC	LDC	ORC	ANDC	XORC	ANDC	LDC	ADD	ADD	Table A.3(2)	Table A.3(2)	MOV	ADDX		Table A.3(2)
1	Table A.3(2)	Table A.3(2)	STMAC	ORC	AND	XOR	AND	Table A.3(2)	Table A.3(2)	SUB	Table A.3(2)	Table A.3(2)	CMP	SUBX		Table A.3(2)
2	MOV, B															
3	MOV, B															
4	BRA	BRN	BHI	BLS	BCC	BCS	BNE	BEQ	BVC	BVS	BPL	BMI	BGE	BLT	BGT	BLE
5	MULXU	DIVXU	MULXU	DIVXU	RTS	BSR	RTE	TRAPA	Table A.3(2)		JMP		BSR		JSR	
6	BSET	BNOT	BCLR	BTST	OR	XOR	AND	BST	MOV	MOV	Table A.3(2)			MOV		
7					BIOR	BXOR	BAND	BLD	MOV	Table A.3(2)	Table A.3(2)	EEMOV				Table A.3(3)
8	ADD															
9	ADDX															
A	CMP															
B	SUBX															
C	OR															
D	XOR															
E	AND															
F	MOV															

Note: * Cannot be used in the chip.

Table A.3 Operation Code Map (2)

Instruction code		1st byte			2nd byte			0	1	2	3	4	5	6	7	8	9	A	B	C	D	E	F
		AH	AL	BH	BL	LDM	STM																
BH	01	MOV																					
0A	0A	INC																					
0B	0B	ADDS																					
0F	0F	DAA																					
10	10	SHLL																					
11	11	SHLR																					
12	12	ROTXL																					
13	13	ROTXR																					
17	17	NOT																					
1A	1A	DEC																					
1B	1B	SUBS																					
1F	1F	DAS																					
58	58	BRA																					
6A	6A	MOV																					
79	79	MOV																					
7A	7A	MOV																					

Note: * Cannot be used in the chip.

Table A.3 Operation Code Map (3)

Instruction code	1st byte		2nd byte		3rd byte		4th byte		9	A	B	C	D	E	F
	AH	AL	BH	BL	CH	CL	DH	DL							
CL	0	1	2	3	4	5	6	7	8						
AH/AL/BH/BL/CH	MULXS	MULXS	MULXS												
01C05															
01D05		DIVXS		DIVXS											
01F06					OR	XOR	AND								
7C06 *1				BTST											
7C07 *1				BTST	BOR	BXOR	BAND	BLD							
7D06 *1	BSET	BNOT	BCLR		BIOR	BIXOR	BIAND	BILD	BSL						
7D07 *1	BSET	BNOT	BCLR						BST						
7Eaa6 *2				BTST											
7Eaa7 *2				BTST	BOR	BXOR	BAND	BLD							
7Faa6 *2	BSET	BNOT	BCLR		BIOR	BIXOR	BIAND	BILD	BSL						
7Faa7 *2	BSET	BNOT	BCLR						BST						



Notes: 1. r is the register specification field.
 2. aa is the absolute address specification.

Table A.3 Operation Code Map (4)

Instruction code		1st byte		2nd byte		3rd byte		4th byte		5th byte		6th byte	
AH	AL	BH	BL	CH	CL	DH	DL	EH	EL	FH	FL	FH	FL

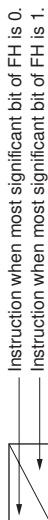

EL	0	1	2	3	4	5	6	7	8	9	A	B	C	D	E	F
AH\LBH\CH\DL\ELER																
6A10aaaa6*				BTST												
6A10aaaa7*					 BOR BIOR 	 BXOR BIXOR 	 BAND BIAND 	 BLD BILD 								
6A18aaaa6*																
6A18aaaa7*																
	BSET	BNOT	BCLR													

Instruction code		1st byte		2nd byte		3rd byte		4th byte		5th byte		7th byte		8th byte	
AH	AL	BH	BL	CH	CL	DH	DL	EH	EL	FH	FL	GH	GL	HH	HL



GL	0	1	2	3	4	5	6	7	8	9	A	B	C	D	E	F
AH\LBH\CH\DL\ELER																
6A30aaaaaaa6*				BTST												
6A30aaaaaaa7*					 BOR BIOR 	 BXOR BIXOR 	 BAND BIAND 	 BLD BILD 								
6A38aaaaaaa6*																
6A38aaaaaaa7*																
	BSET	BNOT	BCLR													

Note: * aa is the absolute address specification.

A.4 Number of States Required for Instruction Execution

The tables in this section can be used to calculate the number of states required for instruction execution by the CPU. Table A.5 indicates the number of instruction fetch, data read/write, and other cycles occurring in each instruction. Table A.4 indicates the number of states required for each cycle. The number of states required for execution of an instruction can be calculated from these two tables as follows:

$$\text{Execution states} = I \times S_I + J \times S_J + K \times S_K + L \times S_L + M \times S_M + N \times S_N$$

Examples: Advanced mode, program code, and stack located in external memory, on-chip supporting modules accessed in two states with 8-bit bus width, external devices accessed in three states with one wait state and 16-bit bus width.

1. BSET #0, @FFFC7:8

From table A.5:

$$I = L = 2, \quad J = K = M = N = 0$$

From table A.4:

$$S_I = 4, \quad S_L = 2$$

$$\text{Number of states required for execution} = 2 \times 4 + 2 \times 2 = 12$$

2. JSR @@30

From table A.5:

$$I = J = K = 2, \quad L = M = N = 0$$

From table A.4:

$$S_I = S_J = S_K = 4$$

$$\text{Number of states required for execution} = 2 \times 4 + 2 \times 4 + 2 \times 4 = 24$$

Table A.4 Number of States per Cycle

Cycle		On-Chip Memory	Access Conditions					
			On-Chip Supporting Module		External Device			
			8-Bit Bus	16-Bit Bus	8-Bit Bus		16-Bit Bus	
				2-State Access	3-State Access	2-State Access	3-State Access	
Instruction fetch	S_I	1	4	2	4	6 + 2m	2	3 + m
Branch address read	S_J							
Stack operation	S_K							
Byte data access	S_L		2		2	3 + m		
Word data access	S_M		4		4	6 + 2m		
Internal operation	S_N	1	1	1	1	1	1	1

Legend:

m: Number of wait states inserted into external device access

Table A.5 Number of Cycles in Instruction Execution

Instruction	Mnemonic	Instruction	Branch	Stack	Byte	Word	Internal
		Fetch	Address Read	Operation	Data Access	Data Access	Operation
		I	J	K	L	M	N
ADD	ADD.B #xx:8,Rd	1					
	ADD.B Rs,Rd	1					
	ADD.W #xx:16,Rd	2					
	ADD.W Rs,Rd	1					
	ADD.L #xx:32,ERd	3					
	ADD.L ERs,ERd	1					
ADDS	ADDS #1/2/4,ERd	1					
ADDX	ADDX #xx:8,Rd	1					
	ADDX Rs,Rd	1					
AND	AND.B #xx:8,Rd	1					
	AND.B Rs,Rd	1					
	AND.W #xx:16,Rd	2					
	AND.W Rs,Rd	1					
	AND.L #xx:32,ERd	3					
	AND.L ERs,ERd	2					
ANDC	ANDC #xx:8,CCR	1					
	ANDC #xx:8,EXR	2					
BAND	BAND #xx:3,Rd	1					
	BAND #xx:3,@ERd	2			1		
	BAND #xx:3,@aa:8	2			1		
	BAND #xx:3,@aa:16	3			1		
	BAND #xx:3,@aa:32	4			1		
Bcc	BRA d:8 (BT d:8)	2					
	BRN d:8 (BF d:8)	2					
	BHI d:8	2					
	BLS d:8	2					
	BCC d:8 (BHS d:8)	2					
	BCS d:8 (BLO d:8)	2					
	BNE d:8	2					
	BEQ d:8	2					
	BVC d:8	2					

Instruction	Mnemonic	Instruction	Branch	Stack	Byte	Word	Internal	
		Fetch	Address	Operation	Data	Data		
		I	J	K	L	M	N	
Bcc	BVS d:8	2						
	BPL d:8	2						
	BMI d:8	2						
	BGE d:8	2						
	BLT d:8	2						
	BGT d:8	2						
	BLE d:8	2						
	BRA d:16 (BT d:16)	2						1
	BRN d:16 (BF d:16)	2						1
	BHI d:16	2						1
	BLS d:16	2						1
	BCC d:16 (BHS d:16)	2						1
	BCS d:16 (BLO d:16)	2						1
	BNE d:16	2						1
	BEQ d:16	2						1
	BVC d:16	2						1
	BVS d:16	2						1
	BPL d:16	2						1
	BMI d:16	2						1
	BGE d:16	2						1
BLT d:16	2						1	
BGT d:16	2						1	
BLE d:16	2						1	
BCLR	BCLR #xx:3,Rd	1						
	BCLR #xx:3,@ERd	2			2			
	BCLR #xx:3,@aa:8	2			2			
	BCLR #xx:3,@aa:16	3			2			
	BCLR #xx:3,@aa:32	4			2			
	BCLR Rn,Rd	1						
	BCLR Rn,@ERd	2			2			
	BCLR Rn,@aa:8	2			2			
	BCLR Rn,@aa:16	3			2			
	BCLR Rn,@aa:32	4			2			

Instruction	Mnemonic	Instruction	Branch	Stack	Byte	Word	Internal
		Fetch	Address	Operation	Data	Data	Operation
		I	J	K	L	M	N
BIAND	BIAND #xx:3,Rd	1					
	BIAND #xx:3,@ERd	2			1		
	BIAND #xx:3,@aa:8	2			1		
	BIAND #xx:3,@aa:16	3			1		
	BIAND #xx:3,@aa:32	4			1		
BILD	BILD #xx:3,Rd	1					
	BILD #xx:3,@ERd	2			1		
	BILD #xx:3,@aa:8	2			1		
	BILD #xx:3,@aa:16	3			1		
	BILD #xx:3,@aa:32	4			1		
BIOR	BIOR #xx:8,Rd	1					
	BIOR #xx:8,@ERd	2			1		
	BIOR #xx:8,@aa:8	2			1		
	BIOR #xx:8,@aa:16	3			1		
	BIOR #xx:8,@aa:32	4			1		
BIST	BIST #xx:3,Rd	1					
	BIST #xx:3,@ERd	2			2		
	BIST #xx:3,@aa:8	2			2		
	BIST #xx:3,@aa:16	3			2		
	BIST #xx:3,@aa:32	4			2		
BIXOR	BIXOR #xx:3,Rd	1					
	BIXOR #xx:3,@ERd	2			1		
	BIXOR #xx:3,@aa:8	2			1		
	BIXOR #xx:3,@aa:16	3			1		
	BIXOR #xx:3,@aa:32	4			1		
BLD	BLD #xx:3,Rd	1					
	BLD #xx:3,@ERd	2			1		
	BLD #xx:3,@aa:8	2			1		
	BLD #xx:3,@aa:16	3			1		
	BLD #xx:3,@aa:32	4			1		

Instruction	Mnemonic	Instruction	Branch	Stack	Byte	Word	Internal
		Fetch	Address	Operation	Data	Data	Operation
		I	J	K	L	M	N
BNOT	BNOT #xx:3,Rd	1					
	BNOT #xx:3,@ERd	2			2		
	BNOT #xx:3,@aa:8	2			2		
	BNOT #xx:3,@aa:16	3			2		
	BNOT #xx:3,@aa:32	4			2		
	BNOT Rn,Rd	1					
	BNOT Rn,@ERd	2				2	
	BNOT Rn,@aa:8	2				2	
	BNOT Rn,@aa:16	3				2	
BNOT Rn,@aa:32	4				2		
BOR	BOR #xx:3,Rd	1					
	BOR #xx:3,@ERd	2			1		
	BOR #xx:3,@aa:8	2			1		
	BOR #xx:3,@aa:16	3			1		
	BOR #xx:3,@aa:32	4			1		
BSET	BSET #xx:3,Rd	1					
	BSET #xx:3,@ERd	2			2		
	BSET #xx:3,@aa:8	2			2		
	BSET #xx:3,@aa:16	3			2		
	BSET #xx:3,@aa:32	4			2		
	BSET Rn,Rd	1					
	BSET Rn,@ERd	2				2	
	BSET Rn,@aa:8	2				2	
	BSET Rn,@aa:16	3				2	
BSET Rn,@aa:32	4				2		
BSR	BSR d:8	2		2			
	BSR d:16	2		2			1
BST	BST #xx:3,Rd	1					
	BST #xx:3,@ERd	2			2		
	BST #xx:3,@aa:8	2			2		
	BST #xx:3,@aa:16	3			2		
	BST #xx:3,@aa:32	4			2		

Instruction	Mnemonic	Instruction	Branch	Stack	Byte	Word	Internal
		Fetch	Address	Operation	Data	Data	Operation
		I	J	K	L	M	N
BTST	BTST #xx:3,Rd	1					
	BTST #xx:3,@ERd	2			1		
	BTST #xx:3,@aa:8	2			1		
	BTST #xx:3,@aa:16	3			1		
	BTST #xx:3,@aa:32	4			1		
	BTST Rn,Rd	1					
	BTST Rn,@ERd	2				1	
	BTST Rn,@aa:8	2				1	
	BTST Rn,@aa:16	3				1	
BTST Rn,@aa:32	4				1		
BXOR	BXOR #xx:3,Rd	1					
	BXOR #xx:3,@ERd	2			1		
	BXOR #xx:3,@aa:8	2			1		
	BXOR #xx:3,@aa:16	3			1		
	BXOR #xx:3,@aa:32	4			1		
CLRMAC	CLRMAC	Cannot be used in the chip					
CMP	CMP.B #xx:8,Rd	1					
	CMP.B Rs,Rd	1					
	CMP.W #xx:16,Rd	2					
	CMP.W Rs,Rd	1					
	CMP.L #xx:32,ERd	3					
	CMP.L ERs,ERd	1					
DAA	DAA Rd	1					
DAS	DAS Rd	1					
DEC	DEC.B Rd	1					
	DEC.W #1/2,Rd	1					
	DEC.L #1/2,ERd	1					
DIVXS	DIVXS.B Rs,Rd	2					11
	DIVXS.W Rs,ERd	2					19
DIVXU	DIVXU.B Rs,Rd	1					11
	DIVXU.W Rs,ERd	1					19

Instruction	Mnemonic	Instruction	Branch	Stack	Byte	Word	Internal
		Fetch	Address	Operation	Data	Data	
		I	J	K	L	M	N
EEPMOV	EEPMOV.B	2			$2n+2^{*2}$		
	EEPMOV.W	2			$2n+2^{*2}$		
EXTS	EXTS.W Rd	1					
	EXTS.L ERd	1					
EXTU	EXTU.W Rd	1					
	EXTU.L ERd	1					
INC	INC.B Rd	1					
	INC.W #1/2,Rd	1					
	INC.L #1/2,ERd	1					
JMP	JMP @ERn	2					
	JMP @aa:24	2					1
	JMP @@aa:8	2	2				1
JSR	JSR @ERn	2		2			
	JSR @aa:24	2		2			1
	JSR @@aa:8	2	2	2			
LDC	LDC #xx:8,CCR	1					
	LDC #xx:8,EXR	2					
	LDC Rs,CCR	1					
	LDC Rs,EXR	1					
	LDC @ERs,CCR	2				1	
	LDC @ERs,EXR	2				1	
	LDC @(d:16,ERs),CCR	3				1	
	LDC @(d:16,ERs),EXR	3				1	
	LDC @(d:32,ERs),CCR	5				1	
	LDC @(d:32,ERs),EXR	5				1	
	LDC @ERs+,CCR	2				1	1
	LDC @ERs+,EXR	2				1	1
	LDC @aa:16,CCR	3				1	
	LDC @aa:16,EXR	3				1	
	LDC @aa:32,CCR	4				1	
LDC @aa:32,EXR	4				1		

Instruction	Mnemonic	Instruction	Branch	Stack	Byte	Word	Internal	
		Fetch	Address	Operation	Data	Data	Operation	
		I	J	K	L	M	N	
LDM	LDM.L @SP+, (ERn-ERn+1)	2		4			1	
	LDM.L @SP+, (ERn-ERn+2)	2		6			1	
	LDM.L @SP+, (ERn-ERn+3)	2		8			1	
LDMAC	LDMAC ERs,MACH	Cannot be used in the chip						
	LDMAC ERs,MACL							
MAC	MAC @ERn+,@ERm+	Cannot be used in the chip						
MOV	MOV.B #xx:8,Rd	1						
	MOV.B Rs,Rd	1						
	MOV.B @ERs,Rd	1			1			
	MOV.B @(d:16,ERs),Rd	2			1			
	MOV.B @(d:32,ERs),Rd	4			1			
	MOV.B @ERs+,Rd	1			1		1	
	MOV.B @aa:8,Rd	1			1			
	MOV.B @aa:16,Rd	2			1			
	MOV.B @aa:32,Rd	3			1			
	MOV.B Rs,@ERd	1			1			
	MOV.B Rs,@(d:16,ERd)	2			1			
	MOV.B Rs,@(d:32,ERd)	4			1			
	MOV.B Rs,@-ERd	1			1		1	
	MOV.B Rs,@aa:8	1			1			
	MOV.B Rs,@aa:16	2			1			
	MOV.B Rs,@aa:32	3			1			
	MOV.W #xx:16,Rd	2						
	MOV.W Rs,Rd	1						
	MOV.W @ERs,Rd	1					1	
	MOV.W @(d:16,ERs),Rd	2					1	
	MOV.W @(d:32,ERs),Rd	4					1	
	MOV.W @ERs+,Rd	1					1	1
	MOV.W @aa:16,Rd	2					1	
MOV.W @aa:32,Rd	3					1		
MOV.W Rs,@ERd	1					1		

Instruction	Mnemonic	Instruction	Branch	Stack	Byte	Word	Internal	
		Fetch	Address		Data	Data		Operation
		I	J	K	L	M	N	
MOV	MOV.W Rs,@(d:16,ERd)	2				1		
	MOV.W Rs,@(d:32,ERd)	4				1		
	MOV.W Rs,@-ERd	1				1	1	
	MOV.W Rs,@aa:16	2				1		
	MOV.W Rs,@aa:32	3				1		
	MOV.L #xx:32,ERd	3						
	MOV.L ERs,ERd	1						
	MOV.L @ERs,ERd	2					2	
	MOV.L @(d:16,ERs),ERd	3					2	
	MOV.L @(d:32,ERs),ERd	5					2	
	MOV.L @ERs+,ERd	2					2	1
	MOV.L @aa:16,ERd	3					2	
	MOV.L @aa:32,ERd	4					2	
	MOV.L ERs,@ERd	2					2	
	MOV.L ERs,@(d:16,ERd)	3					2	
	MOV.L ERs,@(d:32,ERd)	5					2	
	MOV.L ERs,@-ERd	2					2	1
	MOV.L ERs,@aa:16	3					2	
	MOV.L ERs,@aa:32	4					2	
	MOVFPPE	MOVFPPE @:aa:16,Rd	Can not be used in the chip					
MOVTPE	MOVTPE Rs,@:aa:16							
MULXS	MULXS.B Rs,Rd	2					11	
	MULXS.W Rs,ERd	2					19	
MULXU	MULXU.B Rs,Rd	1					11	
	MULXU.W Rs,ERd	1					19	
NEG	NEG.B Rd	1						
	NEG.W Rd	1						
	NEG.L ERd	1						
NOP	NOP	1						
NOT	NOT.B Rd	1						
	NOT.W Rd	1						
	NOT.L ERd	1						

Instruction	Mnemonic	Instruction	Branch	Stack	Byte	Word	Internal
		Fetch	Address	Operation	Data	Data	Operation
		I	J	K	L	M	N
OR	OR.B #xx:8,Rd	1					
	OR.B Rs,Rd	1					
	OR.W #xx:16,Rd	2					
	OR.W Rs,Rd	1					
	OR.L #xx:32,ERd	3					
	OR.L ERs,ERd	2					
ORC	ORC #xx:8,CCR	1					
	ORC #xx:8,EXR	2					
POP	POP.W Rn	1				1	1
	POP.L ERn	2				2	1
PUSH	PUSH.W Rn	1				1	1
	PUSH.L ERn	2				2	1
ROTL	ROTL.B Rd	1					
	ROTL.B #2,Rd	1					
	ROTL.W Rd	1					
	ROTL.W #2,Rd	1					
	ROTL.L ERd	1					
	ROTL.L #2,ERd	1					
ROTR	ROTR.B Rd	1					
	ROTR.B #2,Rd	1					
	ROTR.W Rd	1					
	ROTR.W #2,Rd	1					
	ROTR.L ERd	1					
	ROTR.L #2,ERd	1					
ROTXL	ROTXL.B Rd	1					
	ROTXL.B #2,Rd	1					
	ROTXL.W Rd	1					
	ROTXL.W #2,Rd	1					
	ROTXL.L ERd	1					
	ROTXL.L #2,ERd	1					

Instruction	Mnemonic	Instruction	Branch	Stack	Byte	Word	Internal
		Fetch	Address	Operation	Data	Data	Operation
		I	J	K	L	M	N
ROTXR	ROTXR.B Rd	1					
	ROTXR.B #2,Rd	1					
	ROTXR.W Rd	1					
	ROTXR.W #2,Rd	1					
	ROTXR.L ERd	1					
	ROTXR.L #2,ERd	1					
RTE	RTE	2		2/3*1			1
RTS	RTS	2		2			1
SHAL	SHAL.B Rd	1					
	SHAL.B #2,Rd	1					
	SHAL.W Rd	1					
	SHAL.W #2,Rd	1					
	SHAL.L ERd	1					
	SHAL.L #2,ERd	1					
SHAR	SHAR.B Rd	1					
	SHAR.B #2,Rd	1					
	SHAR.W Rd	1					
	SHAR.W #2,Rd	1					
	SHAR.L ERd	1					
	SHAR.L #2,ERd	1					
SHLL	SHLL.B Rd	1					
	SHLL.B #2,Rd	1					
	SHLL.W Rd	1					
	SHLL.W #2,Rd	1					
	SHLL.L ERd	1					
	SHLL.L #2,ERd	1					
SHLR	SHLR.B Rd	1					
	SHLR.B #2,Rd	1					
	SHLR.W Rd	1					
	SHLR.W #2,Rd	1					
	SHLR.L ERd	1					
	SHLR.L #2,ERd	1					
SLEEP	SLEEP	1					1

Instruction	Mnemonic	Instruction	Branch	Stack	Byte	Word	Internal	
		Fetch	Address	Operation	Data	Data	Operation	
		I	J	K	L	M	N	
STC	STC.B CCR,Rd	1						
	STC.B EXR,Rd	1						
	STC.W CCR,@ERd	2				1		
	STC.W EXR,@ERd	2				1		
	STC.W CCR,@(d:16,ERd)	3				1		
	STC.W EXR,@(d:16,ERd)	3				1		
	STC.W CCR,@(d:32,ERd)	5				1		
	STC.W EXR,@(d:32,ERd)	5				1		
	STC.W CCR,@-ERd	2				1	1	
	STC.W EXR,@-ERd	2				1	1	
	STC.W CCR,@aa:16	3				1		
	STC.W EXR,@aa:16	3				1		
	STC.W CCR,@aa:32	4				1		
	STC.W EXR,@aa:32	4				1		
STM	STM.L (ERn-ERn+1), @-SP	2		4			1	
	STM.L (ERn-ERn+2), @-SP	2		6			1	
	STM.L (ERn-ERn+3), @-SP	2		8			1	
STMAC	STMAC MACH,ERd STMAC MACL,ERd	Cannot be used in the chip						
SUB	SUB.B Rs,Rd	1						
	SUB.W #xx:16,Rd	2						
	SUB.W Rs,Rd	1						
	SUB.L #xx:32,ERd	3						
	SUB.L ERs,ERd	1						
SUBS	SUBS #1/2/4,ERd	1						
SUBX	SUBX #xx:8,Rd	1						
	SUBX Rs,Rd	1						
TAS	TAS @ERd ^{*3}	2			2			
TRAPA	TRAPA #x:2	2	2	2/3 ^{*1}			2	

Instruction	Mnemonic	Instruction	Branch	Stack	Byte	Word	Internal
		Fetch	Address		Data	Data	
		I	J	K	L	M	N
XOR	XOR.B #xx:8,Rd	1					
	XOR.B Rs,Rd	1					
	XOR.W #xx:16,Rd	2					
	XOR.W Rs,Rd	1					
	XOR.L #xx:32,ERd	3					
	XOR.L ERs,ERd	2					
XORC	XORC #xx:8,CCR	1					
	XORC #xx:8,EXR	2					

- Notes:
1. The number of state cycles is 2 when EXR is invalid, and 3 when EXR is valid.
 2. When n bytes of data are transferred.
 3. Only register ER0, ER1, ER4, or ER5 should be used when using the TAS instruction.

A.5 Bus States during Instruction Execution

Table A.6 indicates the types of cycles that occur during instruction execution by the CPU. See table A.4 for the number of states per cycle.

How to Read the Table:

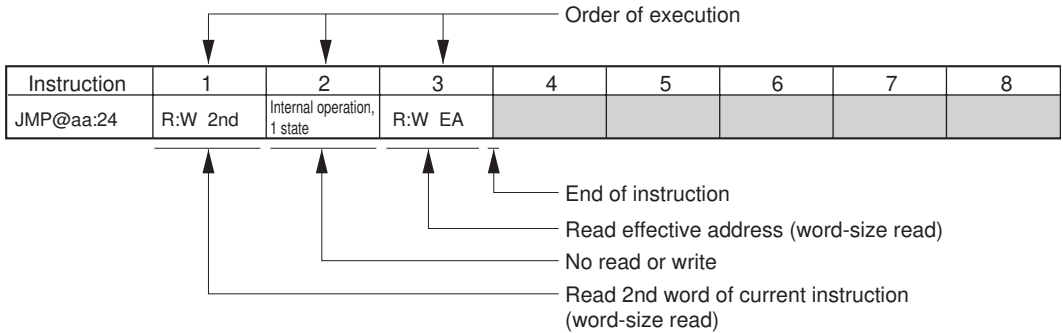

Legend:

R:B	Byte-size read
R:W	Word-size read
W:B	Byte-size write
W:W	Word-size write
:M	Transfer of the bus is not performed immediately after this cycle
2nd	Address of 2nd word (3rd and 4th bytes)
3rd	Address of 3rd word (5th and 6th bytes)
4th	Address of 4th word (7th and 8th bytes)
5th	Address of 5th word (9th and 10th bytes)
NEXT	Address of next instruction
EA	Effective address
VEC	Vector address

Figure A.1 shows timing waveforms for the address bus and the \overline{RD} , \overline{HWR} , and \overline{LWR} signals during execution of the above instruction with an 8-bit bus, using three-state access with no wait states.

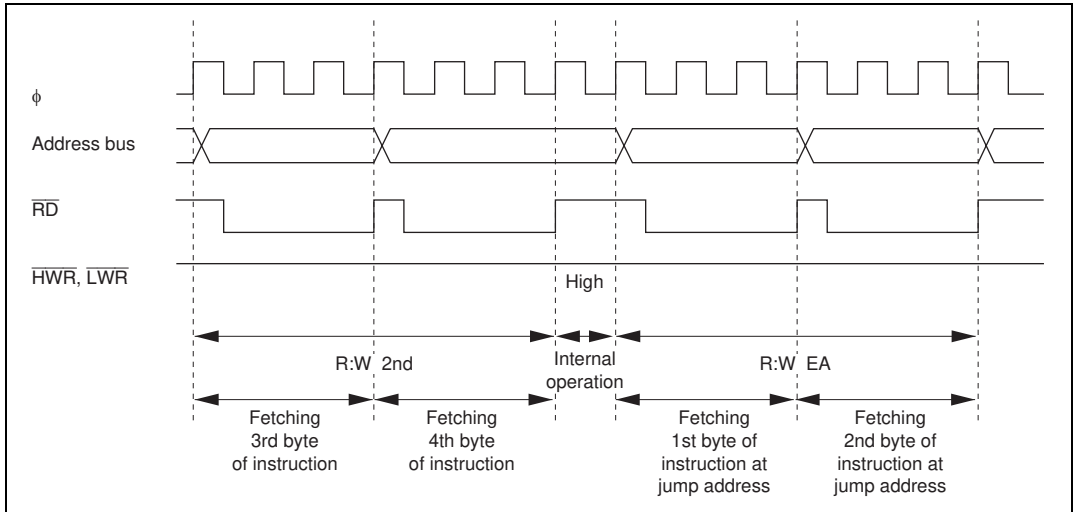

**Figure A.1 Address Bus, \overline{RD} , \overline{HWR} , and \overline{LWR} Timing
(8-Bit Bus, Three-State Access, No Wait States)**

Table A.6 Instruction Execution Cycles

Instruction	1	2	3	4	5	6	7	8	9
ADD.B #xx:8,Rd	R:W NEXT								
ADD.B Rs,Rd	R:W NEXT								
ADD.W #xx:16,Rd	R:W 2nd	R:W NEXT							
ADD.W Rs,Rd	R:W NEXT								
ADD.L #xx:32,ERd	R:W 2nd	R:W 3rd	R:W NEXT						
ADD.L ERs,ERd	R:W NEXT								
ADDS #1/2/4,ERd	R:W NEXT								
ADDX #xx:8,Rd	R:W NEXT								
ADDX Rs,Rd	R:W NEXT								
AND.B #xx:8,Rd	R:W NEXT								
AND.B Rs,Rd	R:W NEXT								
AND.W #xx:16,Rd	R:W 2nd	R:W NEXT							
AND.W Rs,Rd	R:W NEXT								
AND.L #xx:32,ERd	R:W 2nd	R:W 3rd	R:W NEXT						
AND.L ERs,ERd	R:W 2nd	R:W NEXT							
ANDC #xx:8,CCR	R:W NEXT								
ANDC #xx:8,EXR	R:W 2nd	R:W NEXT							
BAND #xx:3,Rd	R:W NEXT								
BAND #xx:3,@ERd	R:W 2nd	R:W 2nd	R:W NEXT						
BAND #xx:3,@aa:8	R:W 2nd	R:W 2nd	R:W NEXT						
BAND #xx:3,@aa:16	R:W 2nd	R:W 3rd	R:W 4th	R:W NEXT					
BAND #xx:3,@aa:32	R:W 2nd	R:W 3rd	R:W 4th	R:W NEXT	R:W NEXT				
BRA d:8 (BT d:8)	R:W NEXT	R:W EA							
BRN d:8 (BF d:8)	R:W NEXT	R:W EA							
BHI d:8	R:W NEXT	R:W EA							
BLS d:8	R:W NEXT	R:W EA							
BCC d:8 (BHS d:8)	R:W NEXT	R:W EA							
BCS d:8 (BLO d:8)	R:W NEXT	R:W EA							
BNE d:8	R:W NEXT	R:W EA							
BEQ d:8	R:W NEXT	R:W EA							
BVC d:8	R:W NEXT	R:W EA							
BVS d:8	R:W NEXT	R:W EA							
BPL d:8	R:W NEXT	R:W EA							
BMI d:8	R:W NEXT	R:W EA							
BGE d:8	R:W NEXT	R:W EA							
BLT d:8	R:W NEXT	R:W EA							
BGT d:8	R:W NEXT	R:W EA							

Instruction	1	2	3	4	5	6	7	8	9
BLE d:8	R:W NEXT	R:W EA							
BRA d:16 (BT d:16)	R:W 2nd	Internal operation, 1 state	R:W EA						
BRN d:16 (BF d:16)	R:W 2nd	Internal operation, 1 state	R:W EA						
BHI d:16	R:W 2nd	Internal operation, 1 state	R:W EA						
BLS d:16	R:W 2nd	Internal operation, 1 state	R:W EA						
BCC d:16 (BHS d:16)	R:W 2nd	Internal operation, 1 state	R:W EA						
BCS d:16 (BLO d:16)	R:W 2nd	Internal operation, 1 state	R:W EA						
BNE d:16	R:W 2nd	Internal operation, 1 state	R:W EA						
BEQ d:16	R:W 2nd	Internal operation, 1 state	R:W EA						
BVC d:16	R:W 2nd	Internal operation, 1 state	R:W EA						
BVS d:16	R:W 2nd	Internal operation, 1 state	R:W EA						
BPL d:16	R:W 2nd	Internal operation, 1 state	R:W EA						
BMI d:16	R:W 2nd	Internal operation, 1 state	R:W EA						
BGE d:16	R:W 2nd	Internal operation, 1 state	R:W EA						
BLT d:16	R:W 2nd	Internal operation, 1 state	R:W EA						
BGT d:16	R:W 2nd	Internal operation, 1 state	R:W EA						
BLE d:16	R:W 2nd	Internal operation, 1 state	R:W EA						
BCLR #xx:3,Rd	R:W NEXT								
BCLR #xx:3,@ERd	R:W 2nd	R:BM EA	R:W:M NEXT W:BEA						
BCLR #xx:3,@aa:8	R:W 2nd	R:BM EA	R:W:M NEXT W:BEA						
BCLR #xx:3,@aa:16	R:W 2nd	R:W 3rd	R:BM EA	R:W:M NEXT W:BEA					

Instruction	1	2	3	4	5	6	7	8	9
BCLR #xx:3,@aa:32	R:W 2nd	R:W 3rd	R:W 4th	R:B:M EA	R:W:M NEXT	W:B EA			
BCLR Rn,Rd	R:W NEXT								
BCLR Rn,@ERd	R:W 2nd	R:B:M EA	R:W:M NEXT	W:B EA					
BCLR Rn,@aa:8	R:W 2nd	R:B:M EA	R:W:M NEXT	W:B EA					
BCLR Rn,@aa:16	R:W 2nd	R:W 3rd	R:B:M EA	R:W:M NEXT	W:B EA				
BCLR Rn,@aa:32	R:W 2nd	R:W 3rd	R:W 4th	R:B:M EA	R:W:M NEXT	W:B EA			
BIAND #xx:3,Rd	R:W NEXT								
BIAND #xx:3,@ERd	R:W 2nd	R:B EA	R:W:M NEXT						
BIAND #xx:3,@aa:8	R:W 2nd	R:B EA	R:W:M NEXT						
BIAND #xx:3,@aa:16	R:W 2nd	R:W 3rd	R:B EA	R:W:M NEXT					
BIAND #xx:3,@aa:32	R:W 2nd	R:W 3rd	R:W 4th	R:B EA	R:W:M NEXT				
BILD #xx:3,Rd	R:W NEXT								
BILD #xx:3,@ERd	R:W 2nd	R:B EA	R:W:M NEXT						
BILD #xx:3,@aa:8	R:W 2nd	R:B EA	R:W:M NEXT						
BILD #xx:3,@aa:16	R:W 2nd	R:W 3rd	R:B EA	R:W:M NEXT					
BILD #xx:3,@aa:32	R:W 2nd	R:W 3rd	R:W 4th	R:B EA	R:W:M NEXT				
BIOR #xx:3,Rd	R:W NEXT								
BIOR #xx:3,@ERd	R:W 2nd	R:B EA	R:W:M NEXT						
BIOR #xx:3,@aa:8	R:W 2nd	R:B EA	R:W:M NEXT						
BIOR #xx:3,@aa:16	R:W 2nd	R:W 3rd	R:B EA	R:W:M NEXT					
BIOR #xx:3,@aa:32	R:W 2nd	R:W 3rd	R:W 4th	R:B EA	R:W:M NEXT				
BIST #xx:3,Rd	R:W NEXT								
BIST #xx:3,@ERd	R:W 2nd	R:B:M EA	R:W:M NEXT	W:B EA					
BIST #xx:3,@aa:8	R:W 2nd	R:B:M EA	R:W:M NEXT	W:B EA					
BIST #xx:3,@aa:16	R:W 2nd	R:W 3rd	R:B:M EA	R:W:M NEXT	W:B EA				
BIST #xx:3,@aa:32	R:W 2nd	R:W 3rd	R:W 4th	R:B:M EA	R:W:M NEXT	W:B EA			
BIXOR #xx:3,Rd	R:W NEXT								
BIXOR #xx:3,@ERd	R:W 2nd	R:B EA	R:W:M NEXT						
BIXOR #xx:3,@aa:8	R:W 2nd	R:B EA	R:W:M NEXT						
BIXOR #xx:3,@aa:16	R:W 2nd	R:W 3rd	R:B EA	R:W:M NEXT					
BIXOR #xx:3,@aa:32	R:W 2nd	R:W 3rd	R:W 4th	R:B EA	R:W:M NEXT				
BLD #xx:3,Rd	R:W NEXT								
BLD #xx:3,@ERd	R:W 2nd	R:B EA	R:W:M NEXT						
BLD #xx:3,@aa:8	R:W 2nd	R:B EA	R:W:M NEXT						
BLD #xx:3,@aa:16	R:W 2nd	R:W 3rd	R:B EA	R:W:M NEXT					
BLD #xx:3,@aa:32	R:W 2nd	R:W 3rd	R:W 4th	R:B EA	R:W:M NEXT				
BNOT #xx:3,Rd	R:W NEXT								

Instruction	1	2	3	4	5	6	7	8	9
BNOT #xx:3,@ERd	R:W 2nd	R:B:M EA	R:W:M NEXT	W:B EA					
BNOT #xx:3,@aa:8	R:W 2nd	R:B:M EA	R:W:M NEXT	W:B EA					
BNOT #xx:3,@aa:16	R:W 2nd	R:W 3rd	R:B:M EA	R:W:M NEXT	W:B EA				
BNOT #xx:3,@aa:32	R:W 2nd	R:W 3rd	R:W 4th	R:B:M EA	R:W:M NEXT	W:B EA			
BNOT Rn,Rd	R:W NEXT								
BNOT Rn,@ERd	R:W 2nd	R:B:M EA	R:W:M NEXT	W:B EA					
BNOT Rn,@aa:8	R:W 2nd	R:B:M EA	R:W:M NEXT	W:B EA					
BNOT Rn,@aa:16	R:W 2nd	R:W 3rd	R:B:M EA	R:W:M NEXT	W:B EA				
BNOT Rn,@aa:32	R:W 2nd	R:W 3rd	R:W 4th	R:B:M EA	R:W:M NEXT	W:B EA			
BOR #xx:3,Rd	R:W NEXT								
BOR #xx:3,@ERd	R:W 2nd	R:B EA	R:W:M NEXT						
BOR #xx:3,@aa:8	R:W 2nd	R:B EA	R:W:M NEXT						
BOR #xx:3,@aa:16	R:W 2nd	R:W 3rd	R:B EA	R:W:M NEXT					
BOR #xx:3,@aa:32	R:W 2nd	R:W 3rd	R:W 4th	R:B EA	R:W:M NEXT				
BSET #xx:3,Rd	R:W NEXT								
BSET #xx:3,@ERd	R:W 2nd	R:B:M EA	R:W:M NEXT	W:B EA					
BSET #xx:3,@aa:8	R:W 2nd	R:B:M EA	R:W:M NEXT	W:B EA					
BSET #xx:3,@aa:16	R:W 2nd	R:W 3rd	R:B:M EA	R:W:M NEXT	W:B EA				
BSET #xx:3,@aa:32	R:W 2nd	R:W 3rd	R:W 4th	R:B:M EA	R:W:M NEXT	W:B EA			
BSET Rn,Rd	R:W NEXT								
BSET Rn,@ERd	R:W 2nd	R:B:M EA	R:W:M NEXT	W:B EA					
BSET Rn,@aa:8	R:W 2nd	R:B:M EA	R:W:M NEXT	W:B EA					
BSET Rn,@aa:16	R:W 2nd	R:W 3rd	R:B:M EA	R:W:M NEXT	W:B EA				
BSET Rn,@aa:32	R:W 2nd	R:W 3rd	R:W 4th	R:B:M EA	R:W:M NEXT	W:B EA			
BSR d:8	R:W NEXT	R:W EA	W:W:M stack (H)	W:W stack (L)					
BSR d:16	R:W 2nd	Internal operation, 1 state	R:W EA	W:W:M stack (H)	W:W stack (L)				
BST #xx:3,Rd	R:W NEXT								
BST #xx:3,@ERd	R:W 2nd	R:B:M EA	R:W:M NEXT	W:B EA					
BST #xx:3,@aa:8	R:W 2nd	R:B:M EA	R:W:M NEXT	W:B EA					
BST #xx:3,@aa:16	R:W 2nd	R:W 3rd	R:B:M EA	R:W:M NEXT	W:B EA				
BST #xx:3,@aa:32	R:W 2nd	R:W 3rd	R:W 4th	R:B:M EA	R:W:M NEXT	W:B EA			
BTST #xx:3,Rd	R:W NEXT								
BTST #xx:3,@ERd	R:W 2nd	R:B EA	R:W:M NEXT						

Instruction	1	2	3	4	5	6	7	8	9
BTST #xx:3,@aa:8	R:W 2nd	R:B EA	R:W:M NEXT						
BTST #xx:3,@aa:16	R:W 2nd	R:W 3rd	R:B EA	R:W:M NEXT					
BTST #xx:3,@aa:32	R:W 2nd	R:W 3rd	R:W 4th	R:B EA	R:W:M NEXT				
BTST Rn,Rd	R:W NEXT								
BTST Rn,@ERd	R:W 2nd	R:B EA	R:W:M NEXT						
BTST Rn,@aa:8	R:W 2nd	R:B EA	R:W:M NEXT						
BTST Rn,@aa:16	R:W 2nd	R:W 3rd	R:B EA	R:W:M NEXT					
BTST Rn,@aa:32	R:W 2nd	R:W 3rd	R:W 4th	R:B EA	R:W:M NEXT				
BXOR #xx:3,Rd	R:W NEXT								
BXOR #xx:3,@ERd	R:W 2nd	R:B EA	R:W:M NEXT						
BXOR #xx:3,@aa:8	R:W 2nd	R:B EA	R:W:M NEXT						
BXOR #xx:3,@aa:16	R:W 2nd	R:W 3rd	R:B EA	R:W:M NEXT					
BXOR #xx:3,@aa:32	R:W 2nd	R:W 3rd	R:W 4th	R:B EA	R:W:M NEXT				
CLRMAC	Cannot be used in the chip								
COMP.B #xx:8,Rd	R:W NEXT								
COMP.B Rs,Rd	R:W NEXT								
COMP.W #xx:16,Rd	R:W NEXT								
COMP.W Rs,Rd	R:W NEXT								
COMP.L #xx:32,ERd	R:W 2nd	R:W 3rd	R:W NEXT						
COMP.L ERs,ERd	R:W NEXT								
DAA Rd	R:W NEXT								
DAS Rd	R:W NEXT								
DEC.B Rd	R:W NEXT								
DEC.W #1/2,Rd	R:W NEXT								
DEC.L #1/2,ERd	R:W NEXT								
DIVXS.B Rs,Rd	R:W 2nd	R:W NEXT	Internal operation, 11 states						
DIVXS.W Rs,ERd	R:W 2nd	R:W NEXT	Internal operation, 19 states						
DIVXU.B Rs,Rd	R:W NEXT	Internal operation, 11 states							
DIVXU.W Rs,ERd	R:W NEXT	Internal operation, 19 states							
EEMOV.B	R:W 2nd	R:B EAs*1	R:B EAd*1	R:B EAs*2	W:B EAd*2	R:W NEXT			
EEMOV.W	R:W 2nd	R:B EAs*1	R:B EAd*1	R:B EAs*2	W:B EAd*2	R:W NEXT			
EXTS.W Rd	R:W NEXT				← Repeated n times*2 →				
EXTS.L ERd	R:W NEXT								
EXTU.W Rd	R:W NEXT								
EXTU.L ERd	R:W NEXT								
INC.B Rd	R:W NEXT								

Instruction	1	2	3	4	5	6	7	8	9
INC.W #1/2,Rd	R:W NEXT								
INC.L #1/2,ERd	R:W NEXT								
JMP @ERn	R:W NEXT	R:W EA							
JMP @aa:24	R:W 2nd	Internal operation, 1 state	R:W EA						
JMP @aa:8	R:W NEXT	R:W:M aa:8	R:W aa:8	Internal operation, 1 state	R:W EA				
JSR @ERn	R:W NEXT	R:W EA	W:W:M stack (H)	W:W stack (L)					
JSR @aa:24	R:W 2nd	Internal operation, 1 state	R:W EA	W:W:M stack (H)	W:W stack (L)				
JSR @aa:8	R:W NEXT	R:W:M aa:8	R:W aa:8	W:W:M stack (H)	W:W stack (L)	R:W EA			
LDC #x:8,CCR	R:W NEXT								
LDC #x:8,EXR	R:W 2nd	R:W NEXT							
LDC Rs,CCR	R:W NEXT								
LDC Rs,EXR	R:W NEXT								
LDC @ERs,CCR	R:W 2nd	R:W NEXT	R:W EA						
LDC @ERs,EXR	R:W 2nd	R:W NEXT	R:W EA						
LDC @(d:16,ERs),CCR	R:W 2nd	R:W 3rd	R:W NEXT	R:W EA					
LDC @(d:16,ERs),EXR	R:W 2nd	R:W 3rd	R:W NEXT	R:W EA					
LDC @(d:32,ERs),CCR	R:W 2nd	R:W 3rd	R:W 4th	R:W 5th	R:W NEXT	R:W EA			
LDC @(d:32,ERs),EXR	R:W 2nd	R:W 3rd	R:W 4th	R:W 5th	R:W NEXT	R:W EA			
LDC @ERs+,CCR	R:W 2nd	R:W NEXT	Internal operation, 1 state	R:W EA					
LDC @ERs+,EXR	R:W 2nd	R:W NEXT	Internal operation, 1 state	R:W EA					
LDC @aa:16,CCR	R:W 2nd	R:W 3rd	R:W NEXT	R:W EA					
LDC @aa:16,EXR	R:W 2nd	R:W 3rd	R:W NEXT	R:W EA					
LDC @aa:32,CCR	R:W 2nd	R:W 3rd	R:W 4th	R:W NEXT	R:W EA				
LDC @aa:32,EXR	R:W 2nd	R:W 3rd	R:W 4th	R:W NEXT	R:W EA				
LDM.L @SP+, (ERn-ERn+1)	R:W 2nd	R:W:M NEXT	Internal operation, 1 state	R:W:M stack (H) ^{*3}	R:W stack (L) ^{*3}				

Instruction	1	2	3	4	5	6	7	8	9
LDM.L @SP+, (ERn-ERn+2)	R:W 2nd	R:W NEXT	Internal operation, 1 state	R:W:M stack (H)*3	R:W stack (L)*3				
LDM.L @SP+, (ERn-ERn+3)	R:W 2nd	R:W NEXT	Internal operation, 1 state	R:W:M stack (H)*3	R:W stack (L)*3				
LDMAC ERs, MACH	Cannot be used in the chip								
LDMAC ERs, MACL	Cannot be used in the chip								
MAC @ERn+, @ERm+	Cannot be used in the chip								
MOV.B #xx:8, Rd	R:W NEXT								
MOV.B Rs, Rd	R:W NEXT								
MOV.B @ERs, Rd	R:W NEXT	R:B EA							
MOV.B @(d:16, ERs), Rd	R:W 2nd	R:W NEXT	R:B EA						
MOV.B @(d:32, ERs), Rd	R:W 2nd	R:W 3rd	R:W 4th	R:W NEXT	R:B EA				
MOV.B @ERs+, Rd	R:W NEXT	Internal operation, 1 state	R:B EA						
MOV.B @aa:8, Rd	R:W NEXT	R:B EA							
MOV.B @aa:16, Rd	R:W 2nd	R:W NEXT	R:B EA						
MOV.B @aa:32, Rd	R:W 2nd	R:W 3rd	R:W NEXT	R:B EA					
MOV.B Rs, @ERd	R:W NEXT	W:B EA							
MOV.B Rs, @(d:16, ERd)	R:W 2nd	R:W NEXT	W:B EA						
MOV.B Rs, @(d:32, ERd)	R:W 2nd	R:W 3rd	R:W 4th	R:W NEXT	W:B EA				
MOV.B Rs, @ERd	R:W NEXT	Internal operation, 1 state	W:B EA						
MOV.B Rs, @aa:8	R:W NEXT	W:B EA							
MOV.B Rs, @aa:16	R:W 2nd	R:W NEXT	W:B EA						
MOV.B Rs, @aa:32	R:W 2nd	R:W 3rd	R:W NEXT	W:B EA					
MOV.W #xx:16, Rd	R:W 2nd	R:W NEXT							
MOV.W Rs, Rd	R:W NEXT								
MOV.W @ERs, Rd	R:W NEXT	R:W EA							
MOV.W @(d:16, ERs), Rd	R:W 2nd	R:W NEXT	R:W EA						
MOV.W @(d:32, ERs), Rd	R:W 2nd	R:W 3rd	R:W 4th	R:W NEXT	R:W EA				
MOV.W @ERs+, Rd	R:W NEXT	Internal operation, 1 state	R:W EA						
MOV.W @aa:16, Rd	R:W 2nd	R:W NEXT	R:W EA						
MOV.W @aa:32, Rd	R:W 2nd	R:W 3rd	R:W NEXT	R:B EA					
MOV.W Rs, @ERd	R:W NEXT	W:W EA							

Instruction	1	2	3	4	5	6	7	8	9
MOV.W Rs.@(d:16,ERd)	R:W 2nd	R:W NEXT	W:W EA						
MOV.W Rs.@(d:32,ERd)	R:W 2nd	R:W 3rd	R:E 4th	R:W NEXT	W:W EA				
MOV.W Rs.@-ERd	R:W NEXT	Internal operation, 1 state	W:W EA						
MOV.W Rs.@aa:16	R:W 2nd	R:W NEXT	W:W EA						
MOV.W Rs.@aa:32	R:W 2nd	R:W 3rd	R:W NEXT	W:W EA					
MOV.L #xx:32,ERd	R:W 2nd	R:W 3rd	R:W NEXT						
MOV.L ERs,ERd	R:W NEXT								
MOV.L @ERs,ERd	R:W 2nd	R:W:M NEXT	R:W:M EA	R:W:EA+2					
MOV.L @(d:16,ERs),ERd	R:W 2nd	R:W:M 3rd	R:W NEXT	R:W:M EA	R:W:EA+2				
MOV.L @(d:32,ERs),ERd	R:W 2nd	R:W:M 3rd	R:W:M 4th	R:W:5th	R:W NEXT	R:W:M EA	R:W:EA+2		
MOV.L @ERs+,ERd	R:W 2nd	R:W:M NEXT	Internal operation, 1 state	R:W:M EA	R:W:EA+2				
MOV.L @aa:16,ERd	R:W 2nd	R:W:M 3rd	R:W NEXT	R:W:M EA	R:W:EA+2				
MOV.L @aa:32,ERd	R:W 2nd	R:W:M 3rd	R:W 4th	R:W NEXT	R:W:M EA	R:W:EA+2			
MOV.L ERs@ERd	R:W 2nd	R:W:M NEXT	W:W:M EA	W:W:EA+2					
MOV.L ERs@(d:16,ERd)	R:W 2nd	R:W:M 3rd	R:W NEXT	W:W:M EA	W:W:EA+2				
MOV.L ERs@(d:32,ERd)	R:W 2nd	R:W:M 3rd	R:W:M 4th	R:W:5th	R:W NEXT	W:W:M EA	W:W:EA+2		
MOV.L ERs@-ERd	R:W 2nd	R:W:M NEXT	Internal operation, 1 state	W:W:M EA	W:W:EA+2				
MOV.L ERs@aa:16	R:W 2nd	R:W:M 3rd	R:W NEXT	W:W:M EA	W:W:EA+2				
MOV.L ERs@aa:32	R:W 2nd	R:W:M 3rd	R:W 4th	R:W NEXT	W:W:M EA	W:W:EA+2			
MOV.FPE @aa:16,Rd	Cannot be used in the chip								
MOV.TPE Rs,@aa:16									
MUL.XS.B Rs,Rd	R:W 2nd	R:W NEXT	Internal operation, 11 states						
MUL.XS.W Rs,ERd	R:W 2nd	R:W NEXT	Internal operation, 19 states						
MUL.XU.B Rs,Rd	R:W NEXT	Internal operation, 11 states							
MUL.XU.W Rs,ERd	R:W NEXT	Internal operation, 19 states							
NEG.B Rd	R:W NEXT								
NEG.W Rd	R:W NEXT								
NEG.L ERd	R:W NEXT								
NOP	R:W NEXT								
NOT.B Rd	R:W NEXT								
NOT.W Rd	R:W NEXT								
NOT.L ERd	R:W NEXT								
OR.B #xx:8,Rd	R:W NEXT								
OR.B Rs,Rd	R:W NEXT								

Instruction	1	2	3	4	5	6	7	8	9
OR.W #xx:16,Rd	R:W 2nd	R:W NEXT							
OR.W Rs,Rd	R:W NEXT								
OR.L #xx:32,ERd	R:W 2nd	R:W 3rd	R:W NEXT						
OR.L ERs,ERd	R:W 2nd	R:W NEXT							
ORC #xx:8,CCR	R:W 2nd	R:W NEXT							
ORC #xx:8,EXR	R:W 2nd	Internal operation, 1 state	R:W EA						
POP.W Rn	R:W NEXT	Internal operation, 1 state							
POP.L ERn	R:W 2nd	R:W:M NEXT	Internal operation, 1 state	R:W:M EA	R:W EA+2				
PUSH.W Rn	R:W NEXT	Internal operation, 1 state	W:W EA						
PUSH.L ERn	R:W 2nd	R:W:M NEXT	Internal operation, 1 state	W:W:M EA	W:W EA+2				
ROTL.B Rd	R:W NEXT								
ROTL.B #2,Rd	R:W NEXT								
ROTL.W Rd	R:W NEXT								
ROTL.W #2,Rd	R:W NEXT								
ROTL.L ERd	R:W NEXT								
ROTL.L #2,ERd	R:W NEXT								
ROTR.B Rd	R:W NEXT								
ROTR.B #2,Rd	R:W NEXT								
ROTR.W Rd	R:W NEXT								
ROTR.W #2,Rd	R:W NEXT								
ROTR.L ERd	R:W NEXT								
ROTR.L #2,ERd	R:W NEXT								
ROTXL.B Rd	R:W NEXT								
ROTXL.B #2,Rd	R:W NEXT								
ROTXL.W Rd	R:W NEXT								
ROTXL.W #2,Rd	R:W NEXT								
ROTXL.L ERd	R:W NEXT								
ROTXL.L #2,ERd	R:W NEXT								
ROTXR.B Rd	R:W NEXT								
ROTXR.B #2,Rd	R:W NEXT								
ROTXR.W Rd	R:W NEXT								
ROTXR.W #2,Rd	R:W NEXT								
ROTXR.L ERd	R:W NEXT								

Instruction	1	2	3	4	5	6	7	8	9
ROTXR.L #2,ERd	R:W NEXT	R:W stack (EXR)	R:W stack (H)	R:W stack (L)	Internal operation, 1 state	R:W ⁴			
RTE	R:W NEXT	R:W stack (EXR)	R:W stack (H)	R:W stack (L)	Internal operation, 1 state	R:W ⁴			
RTS	R:W NEXT	R:W stack (H)	R:W stack (L)	Internal operation, 1 state					
SHAL.B Rd	R:W NEXT								
SHAL.B #2,Rd	R:W NEXT								
SHAL.W Rd	R:W NEXT								
SHAL.W #2,Rd	R:W NEXT								
SHALL.ERd	R:W NEXT								
SHALL.#2,ERd	R:W NEXT								
SHAR.B Rd	R:W NEXT								
SHAR.B #2,Rd	R:W NEXT								
SHAR.W Rd	R:W NEXT								
SHAR.W #2,Rd	R:W NEXT								
SHAR.L ERd	R:W NEXT								
SHAR.L #2,ERd	R:W NEXT								
SHLL.B Rd	R:W NEXT								
SHLL.B #2,Rd	R:W NEXT								
SHLL.W Rd	R:W NEXT								
SHLL.W #2,Rd	R:W NEXT								
SHLLL.ERd	R:W NEXT								
SHLLL.#2,ERd	R:W NEXT								
SHLR.B Rd	R:W NEXT								
SHLR.B #2,Rd	R:W NEXT								
SHLR.W Rd	R:W NEXT								
SHLR.W #2,Rd	R:W NEXT								
SHLR.L ERd	R:W NEXT								
SHLR.L #2,ERd	R:W NEXT	Internal operation;W							
SLEEP	R:W NEXT	Internal operation;W							
STC CCR,Rd	R:W NEXT								
STC EXR,Rd	R:W NEXT								
STC CCR,@ERd	R:W 2nd	R:W NEXT	W:W EA						
STC EXR,@ERd	R:W 2nd	R:W NEXT	W:W EA						
STC CCR,@(d:16,ERd)	R:W 2nd	R:W 3rd	R:W NEXT	W:W EA					

Instruction	1	2	3	4	5	6	7	8	9
STC EXP,@(d:16,ERd)	R:W 2nd	R:W 3rd	R:W NEXT	W:W EA					
STC CCR,@(d:32,ERd)	R:W 2nd	R:W 3rd	R:W 4th	R:W 5th	R:W NEXT	W:W EA			
STC EXR,@(d:32,ERd)	R:W 2nd	R:W 3rd	R:W 4th	R:W 5th	R:W NEXT	W:W EA			
STC CCR,@_ERd	R:W 2nd	R:W NEXT	Internal operation, 1 state	W:W EA					
STC EXR,@_ERd	R:W 2nd	R:W NEXT	Internal operation, 1 state	W:W EA					
STC CCR,@aa:16	R:W 2nd	R:W 3rd	R:W NEXT	W:W EA					
STC EXR,@aa:16	R:W 2nd	R:W 3rd	R:W NEXT	W:W EA					
STC CCR,@aa:32	R:W 2nd	R:W 3rd	R:W 4th	R:W NEXT	W:W EA				
STC EXR,@aa:32	R:W 2nd	R:W 3rd	R:W 4th	R:W NEXT	W:W EA				
STMLL(ERn-ERn+1),@_SP	R:W 2nd	R:W:M NEXT	Internal operation, 1 state	W:W:M stack (H) ^{*3}	W:W stack (L) ^{*3}				
STMLL(ERn-ERn+2),@_SP	R:W 2nd	R:W:M NEXT	Internal operation, 1 state	W:W:M stack (H) ^{*3}	W:W stack (L) ^{*3}				
STMLL(ERn-ERn+3),@_SP	R:W 2nd	R:W:M NEXT	Internal operation, 1 state	W:W:M stack (H) ^{*3}	W:W stack (L) ^{*3}				
STMAC MACH,ERd	Cannot be used in the chip								
STMAC MACL,ERd	Cannot be used in the chip								
SUB.B Rs,Rd	R:W NEXT								
SUB.W #xx:16,Rd	R:W 2nd	R:W NEXT							
SUB.W Rs,Rd	R:W NEXT								
SUB.L #xx:32,ERd	R:W 2nd	R:W 3rd	R:W NEXT						
SUB.L ERs,ERd	R:W NEXT								
SUBS #1/2/4,ERd	R:W NEXT								
SUBX #xx:8,Rd	R:W NEXT								
SUBX Rs,Rd	R:W NEXT								
TAS @ERd ^{*8}	R:W 2nd	R:W NEXT	R:B:M EA	W:B EA					
TRAPA #x:2	R:W NEXT	Internal operation, 1 state	W:W stack (L)	W:W stack (H)	W:W stack (EXR)	R:W:M VEC	R:W VEC+2	Internal operation, 1 state	R:W ^{*7}
XOR.B #xx:8,Rd	R:W NEXT								
XOR.B Rs,Rd	R:W NEXT								
XOR.W #xx:16,Rd	R:W 2nd	R:W NEXT							
XOR.W Rs,Rd	R:W NEXT								
XOR.L #xx:32,ERd	R:W 2nd	R:W 3rd	R:W NEXT						

Instruction	1	2	3	4	5	6	7	8	9
XOR.L ERs, ERd	R:W 2nd	R:W NEXT							
XORC #x:8,CCR	R:W NEXT								
XORC #x:8,EXR	R:W 2nd	R:W NEXT							
Reset exception handling	R:W VEC	R:W VEC+2	Internal operation, 1 state	R:W ⁿ⁵					
Interrupt exception handling	R:W ⁿ⁶	Internal operation, 1 state	W:W stack (L)	W:W stack (H)	W:W stack (EXR)	R:W:M VEC	R:W VEC+2	Internal operation, 1 state	R:W ⁿ⁷

Notes: 1. EAs is the contents of ER5. EAd is the contents of ER6.

- EAs is the contents of ER5. EAd is the contents of ER6. Both registers are incremented by 1 after execution of the instruction. n is the initial value of R4L or R4. If n = 0, these bus cycles are not executed.
- Repeated two times to save or restore two registers, three times for three registers, or four times for four registers.
- Start address after return.
- Start address of the program.
- Prefetch address, equal to two plus the PC value pushed onto the stack. In recovery from sleep mode or software standby mode the read operation is replaced by an internal operation.
- Start address of the interrupt handling routine.
- Only register ER0, ER1, ER4, or ER5 should be used when using the TAS instruction.

A.6 Condition Code Modification

This section indicates the effect of each CPU instruction on the condition code. The notation used in the table is defined below.

$$m = \begin{cases} 31 & \text{for longword operands} \\ 15 & \text{for word operands} \\ 7 & \text{for byte operands} \end{cases}$$

Si	The i-th bit of the source operand
Di	The i-th bit of the destination operand
Ri	The i-th bit of the result
Dn	The specified bit in the destination operand
—	Not affected
↑	Modified according to the result of the instruction (see definition)
0	Always cleared to 0
1	Always set to 1
*	Undetermined (no guaranteed value)
Z'	Z flag before instruction execution
C'	C flag before instruction execution

Table A.7 Condition Code Modification

Instruction	H	N	Z	V	C	Definition
ADD	↑	↑	↑	↑	↑	$H = S_{m-4} \cdot D_{m-4} + D_{m-4} \cdot \overline{R_{m-4}} + S_{m-4} \cdot \overline{R_{m-4}}$ $N = R_m$ $Z = \overline{R_m} \cdot \overline{R_{m-1}} \cdot \dots \cdot \overline{R_0}$ $V = S_m \cdot D_m \cdot \overline{R_m} + \overline{S_m} \cdot \overline{D_m} \cdot R_m$ $C = S_m \cdot D_m + D_m \cdot \overline{R_m} + S_m \cdot \overline{R_m}$
ADDS	—	—	—	—	—	
ADDX	↑	↑	↑	↑	↑	$H = S_{m-4} \cdot D_{m-4} + D_{m-4} \cdot \overline{R_{m-4}} + S_{m-4} \cdot \overline{R_{m-4}}$ $N = R_m$ $Z = Z' \cdot \overline{R_m} \cdot \dots \cdot \overline{R_0}$ $V = S_m \cdot D_m \cdot \overline{R_m} + \overline{S_m} \cdot \overline{D_m} \cdot R_m$ $C = S_m \cdot D_m + D_m \cdot \overline{R_m} + S_m \cdot \overline{R_m}$
AND	—	↑	↑	0	—	$N = R_m$ $Z = \overline{R_m} \cdot \overline{R_{m-1}} \cdot \dots \cdot \overline{R_0}$
ANDC	↑	↑	↑	↑	↑	Stores the corresponding bits of the result. No flags change when the operand is EXR.
BAND	—	—	—	—	↑	$C = C' \cdot D_n$
Bcc	—	—	—	—	—	
BCLR	—	—	—	—	—	
BIAND	—	—	—	—	↑	$C = C' \cdot \overline{D_n}$
BILD	—	—	—	—	↑	$C = \overline{D_n}$
BIOR	—	—	—	—	↑	$C = C' + \overline{D_n}$
BIST	—	—	—	—	—	
BIXOR	—	—	—	—	↑	$C = C' \cdot D_n + \overline{C'} \cdot \overline{D_n}$
BLD	—	—	—	—	↑	$C = D_n$
BNOT	—	—	—	—	—	
BOR	—	—	—	—	↑	$C = C' + D_n$
BSET	—	—	—	—	—	
BSR	—	—	—	—	—	
BST	—	—	—	—	—	
BTST	—	—	↑	—	—	$Z = \overline{D_n}$
BXOR	—	—	—	—	↑	$C = C' \cdot \overline{D_n} + \overline{C'} \cdot D_n$
CLRMAC						Cannot be used in the chip

Instruction	H	N	Z	V	C	Definition
CMP	↑	↑	↑	↑	↑	$H = \overline{S_{m-4}} \cdot \overline{D_{m-4}} + \overline{D_{m-4}} \cdot R_{m-4} + S_{m-4} \cdot R_{m-4}$ $N = R_m$ $Z = \overline{R_m} \cdot \overline{R_{m-1}} \cdot \dots \cdot \overline{R_0}$ $V = \overline{S_m} \cdot D_m \cdot \overline{R_m} + S_m \cdot \overline{D_m} \cdot R_m$ $C = S_m \cdot \overline{D_m} + \overline{D_m} \cdot R_m + S_m \cdot R_m$
DAA	*	↑	↑	*	↑	$N = R_m$ $Z = \overline{R_m} \cdot \overline{R_{m-1}} \cdot \dots \cdot \overline{R_0}$ C: decimal arithmetic carry
DAS	*	↑	↑	*	↑	$N = R_m$ $Z = \overline{R_m} \cdot \overline{R_{m-1}} \cdot \dots \cdot \overline{R_0}$ C: decimal arithmetic borrow
DEC	—	↑	↑	↑	—	$N = R_m$ $Z = \overline{R_m} \cdot \overline{R_{m-1}} \cdot \dots \cdot \overline{R_0}$ $V = D_m \cdot \overline{R_m}$
DIVXS	—	↑	↑	—	—	$N = S_m \cdot \overline{D_m} + \overline{S_m} \cdot D_m$ $Z = \overline{S_m} \cdot \overline{S_{m-1}} \cdot \dots \cdot \overline{S_0}$
DIVXU	—	↑	↑	—	—	$N = S_m$ $Z = \overline{S_m} \cdot \overline{S_{m-1}} \cdot \dots \cdot \overline{S_0}$
EEPMOV	—	—	—	—	—	
EXTS	—	↑	↑	0	—	$N = R_m$ $Z = \overline{R_m} \cdot \overline{R_{m-1}} \cdot \dots \cdot \overline{R_0}$
EXTU	—	0	↑	0	—	$Z = \overline{R_m} \cdot \overline{R_{m-1}} \cdot \dots \cdot \overline{R_0}$
INC	—	↑	↑	↑	—	$N = R_m$ $Z = \overline{R_m} \cdot \overline{R_{m-1}} \cdot \dots \cdot \overline{R_0}$ $V = \overline{D_m} \cdot R_m$
JMP	—	—	—	—	—	
JSR	—	—	—	—	—	
LDC	↑	↑	↑	↑	↑	Stores the corresponding bits of the result. No flags change when the operand is EXR.
LDM	—	—	—	—	—	
LDMAC						Cannot be used in the chip
MAC						

Instruction	H	N	Z	V	C	Definition
MOV	—	↑	↑	0	—	$N = R_m$ $Z = \overline{R_m} \cdot \overline{R_{m-1}} \cdot \dots \cdot \overline{R_0}$
MOVFPPE						Cannot be used in the chip
MOVTPE						
MULXS	—	↑	↑	—	—	$N = R_{2m}$ $Z = \overline{R_{2m}} \cdot \overline{R_{2m-1}} \cdot \dots \cdot \overline{R_0}$
MULXU	—	—	—	—	—	
NEG	↑	↑	↑	↑	↑	$H = D_{m-4} + R_{m-4}$ $N = R_m$ $Z = \overline{R_m} \cdot \overline{R_{m-1}} \cdot \dots \cdot \overline{R_0}$ $V = D_m \cdot R_m$ $C = D_m + R_m$
NOP	—	—	—	—	—	
NOT	—	↑	↑	0	—	$N = R_m$ $Z = \overline{R_m} \cdot \overline{R_{m-1}} \cdot \dots \cdot \overline{R_0}$
OR	—	↑	↑	0	—	$N = R_m$ $Z = \overline{R_m} \cdot \overline{R_{m-1}} \cdot \dots \cdot \overline{R_0}$
ORC	↑	↑	↑	↑	↑	Stores the corresponding bits of the result. No flags change when the operand is EXR.
POP	—	↑	↑	0	—	$N = R_m$ $Z = \overline{R_m} \cdot \overline{R_{m-1}} \cdot \dots \cdot \overline{R_0}$
PUSH	—	↑	↑	0	—	$N = R_m$ $Z = \overline{R_m} \cdot \overline{R_{m-1}} \cdot \dots \cdot \overline{R_0}$
ROTL	—	↑	↑	0	↑	$N = R_m$ $Z = \overline{R_m} \cdot \overline{R_{m-1}} \cdot \dots \cdot \overline{R_0}$ $C = D_m$ (1-bit shift) or $C = D_{m-1}$ (2-bit shift)
ROTR	—	↑	↑	0	↑	$N = R_m$ $Z = \overline{R_m} \cdot \overline{R_{m-1}} \cdot \dots \cdot \overline{R_0}$ $C = D_0$ (1-bit shift) or $C = D_1$ (2-bit shift)

Instruction	H	N	Z	V	C	Definition
ROTXL	—	↓	↓	0	↓	N = Rm Z = $\overline{Rm} \cdot \overline{Rm-1} \cdot \dots \cdot \overline{R0}$ C = Dm (1-bit shift) or C = Dm-1 (2-bit shift)
ROTXR	—	↓	↓	0	↓	N = Rm Z = $\overline{Rm} \cdot \overline{Rm-1} \cdot \dots \cdot \overline{R0}$ C = D0 (1-bit shift) or C = D1 (2-bit shift)
RTE	↓	↓	↓	↓	↓	Stores the corresponding bits of the result.
RTS	—	—	—	—	—	
SHAL	—	↓	↓	↓	↓	N = Rm Z = $\overline{Rm} \cdot \overline{Rm-1} \cdot \dots \cdot \overline{R0}$ V = $\overline{Dm \cdot Dm-1 + Dm \cdot Dm-1}$ (1-bit shift) V = $\overline{Dm \cdot Dm-1 \cdot Dm-2 \cdot Dm \cdot Dm-1 \cdot Dm-2}$ (2-bit shift) C = Dm (1-bit shift) or C = Dm-1 (2-bit shift)
SHAR	—	↓	↓	0	↓	N = Rm Z = $\overline{Rm} \cdot \overline{Rm-1} \cdot \dots \cdot \overline{R0}$ C = D0 (1-bit shift) or C = D1 (2-bit shift)
SHLL	—	↓	↓	0	↓	N = Rm Z = $\overline{Rm} \cdot \overline{Rm-1} \cdot \dots \cdot \overline{R0}$ C = Dm (1-bit shift) or C = Dm-1 (2-bit shift)
SHLR	—	0	↓	0	↓	N = Rm Z = $\overline{Rm} \cdot \overline{Rm-1} \cdot \dots \cdot \overline{R0}$ C = D0 (1-bit shift) or C = D1 (2-bit shift)
SLEEP	—	—	—	—	—	
STC	—	—	—	—	—	
STM	—	—	—	—	—	
STMAC						Cannot be used in the chip

Instruction	H	N	Z	V	C	Definition
SUB	↑	↑	↑	↑	↑	$H = S_{m-4} \cdot \overline{D_{m-4}} + \overline{D_{m-4}} \cdot R_{m-4} + S_{m-4} \cdot R_{m-4}$ $N = R_m$ $Z = \overline{R_m} \cdot \overline{R_{m-1}} \cdot \dots \cdot \overline{R_0}$ $V = \overline{S_m} \cdot D_m \cdot \overline{R_m} + S_m \cdot \overline{D_m} \cdot R_m$ $C = S_m \cdot \overline{D_m} + \overline{D_m} \cdot R_m + S_m \cdot R_m$
SUBS	—	—	—	—	—	
SUBX	↑	↑	↑	↑	↑	$H = S_{m-4} \cdot \overline{D_{m-4}} + \overline{D_{m-4}} \cdot R_{m-4} + S_{m-4} \cdot R_{m-4}$ $N = R_m$ $Z = Z' \cdot \overline{R_m} \cdot \dots \cdot \overline{R_0}$ $V = \overline{S_m} \cdot D_m \cdot \overline{R_m} + S_m \cdot \overline{D_m} \cdot R_m$ $C = S_m \cdot \overline{D_m} + \overline{D_m} \cdot R_m + S_m \cdot R_m$
TAS	—	↑	↑	0	—	$N = D_m$ $Z = \overline{D_m} \cdot \overline{D_{m-1}} \cdot \dots \cdot \overline{D_0}$
TRAPA	—	—	—	—	—	
XOR	—	↑	↑	0	—	$N = R_m$ $Z = \overline{R_m} \cdot \overline{R_{m-1}} \cdot \dots \cdot \overline{R_0}$
XORC	↑	↑	↑	↑	↑	Stores the corresponding bits of the result. No flags change when the operand is EXR.

Appendix B Internal I/O Registers

B.1 List of Registers (Address Order)

Address	Register									Module Name	Data Bus Width
	Name	Bit 7	Bit 6	Bit 5	Bit 4	Bit 3	Bit 2	Bit 1	Bit 0		
H'F800	MRA	SM1	SM0	DM1	DM0	MD1	MD0	DTS	Sz	DTC	16/32*1 bits
to	SAR										
H'FBFF											
	MRB	CHNE	DISEL	CHNS	—	—	—	—	—		
	DAR										
	CRA										
	CRB										
H'FE80	TCR3	CCLR2	CCLR1	CCLR0	CKEG1	CKEG0	TPSC2	TPSC1	TPSC0	TPU3	16 bits
H'FE81	TMDR3	—	—	BFB	BFA	MD3	MD2	MD1	MD0		
H'FE82	TIOR3H	IOB3	IOB2	IOB1	IOB0	IOA3	IOA2	IOA1	IOA0		
H'FE83	TIOR3L	IOD3	IOD2	IOD1	IOD0	IOC3	IOC2	IOC1	IOC0		
H'FE84	TIER3	TTGE	—	—	TCIEV	TGIED	TGIEC	TGIEB	TGIEA		
H'FE85	TSR3	—	—	—	TCFV	TGFD	TGFC	TGFB	TGFA		
H'FE86	TCNT3										
H'FE87											
H'FE88	TGR3A										
H'FE89											
H'FE8A	TGR3B										
H'FE8B											
H'FE8C	TGR3C										
H'FE8D											
H'FE8E	TGR3D										
H'FE8F											

Address	Register Name	Bit 7	Bit 6	Bit 5	Bit 4	Bit 3	Bit 2	Bit 1	Bit 0	Module Name	Data Bus Width
H'FE90	TCR4	—	CCLR1	CCLR0	CKEG	CKEG0	TPSC2	TPSC1	TPSC0	TPU4	16 bits
H'FE91	TMDR4	—	—	—	—	MD3	MD2	MD1	MD0		
H'FE92	TIOR4	IOB3	IOB2	IOB1	IOB0	IOA3	IOA2	IOA1	IOA0		
H'FE94	TIER4	TTGE	—	TCIEU	TCIEV	—	—	TGIEB	TGIEA		
H'FE95	TSR4	TCFD	—	TCFU	TCFV	—	—	TGFB	TGFA		
H'FE96	TCNT4										
H'FE97											
H'FE98	TGR4A										
H'FE99											
H'FE9A	TGR4B										
H'FE9B											
H'FEA0	TCR5	—	CCLR1	CCLR0	CKEG1	CKEG0	TPSC2	TPSC1	TPSC0	TPU5	16 bits
H'FEA1	TMDR5	—	—	—	—	MD3	MD2	MD1	MD0		
H'FEA2	TIOR5	IOB3	IOB2	IOB1	IOB0	IOA3	IOA2	IOA1	IOA0		
H'FEA4	TIER5	TTGE	—	TCIEU	TCIEV	—	—	TGIEB	TGIEA		
H'FEA5	TSR5	TCFD	—	TCFU	TCFV	—	—	TGFB	TGFA		
H'FEA6	TCNT5										
H'FEA7											
H'FEA8	TGR5A										
H'FEA9											
H'FEAA	TGR5B										
H'FEAB											
H'FEB0	P1DDR	P17DDR	P16DDR	P15DDR	P14DDR	P13DDR	P12DDR	P11DDR	P10DDR	Ports	8 bits
H'FEB1	P2DDR	P27DDR	P26DDR	P25DDR	P24DDR	P23DDR	P22DDR	P21DDR	P20DDR		
H'FEB2	P3DDR	—	—	P35DDR	P34DDR	P33DDR	P32DDR	P31DDR	P30DDR		
H'FEB9	PADDR	—	—	—	—	PA3DDR	PA2DDR	PA1DDR	PA0DDR		
H'FEBA	PBDDR	PB7DDR	PB6DDR	PB5DDR	PB4DDR	PB3DDR	PB2DDR	PB1DDR	PB0DDR		
H'FEBB	PCDDR	PC7DDR	PC6DDR	PC5DDR	PC4DDR	PC3DDR	PC2DDR	PC1DDR	PC0DDR		
H'FEB C	PDDDR	PD7DDR	PD6DDR	PD5DDR	PD4DDR	PD3DDR	PD2DDR	PD1DDR	PD0DDR		
H'FEBD	PEDDR	PE7DDR	PE6DDR	PE5DDR	PE4DDR	PE3DDR	PE2DDR	PE1DDR	PE0DDR		
H'FEBE	PFDDR	PF7DDR	PF6DDR	PF5DDR	PF4DDR	PF3DDR	PF2DDR	PF1DDR	PF0DDR		
H'FEBF	PGDDR	—	—	—	PG4DDR	PG3DDR	PG2DDR	PG1DDR	PG0DDR		

Appendix B Internal I/O Registers

Address	Register Name	Bit 7	Bit 6	Bit 5	Bit 4	Bit 3	Bit 2	Bit 1	Bit 0	Module Name	Data Bus Width
H'FEC4	IPRA	—	IPR6	IPR5	IPR4	—	IPR2	IPR1	IPR0	Interrupt controller	8 bits
H'FEC5	IPRB	—	IPR6	IPR5	IPR4	—	IPR2	IPR1	IPR0		
H'FEC6	IPRC	—	IPR6	IPR5	IPR4	—	IPR2	IPR1	IPR0		
H'FEC7	IPRD	—	IPR6	IPR5	IPR4	—	—	—	—		
H'FEC8	IPRE	—	—	—	—	—	IPR2	IPR1	IPR0		
H'FEC9	IPRF	—	IPR6	IPR5	IPR4	—	IPR2	IPR1	IPR0		
H'FECA	IPRG	—	IPR6	IPR5	IPR4	—	IPR2	IPR1	IPR0		
H'FECB	IPRH	—	IPR6	IPR5	IPR4	—	IPR2	IPR1	IPR0		
H'FECC	IPRI	—	IPR6	IPR5	IPR4	—	IPR2	IPR1	IPR0		
H'FECD	IPRJ	—	—	—	—	—	IPR2	IPR1	IPR0		
H'FECE	IPRK	—	IPR6	IPR5	IPR4	—	—	—	—		
H'FED0	ABWCR	ABW7	ABW6	ABW5	ABW4	ABW3	ABW2	ABW1	ABW0	Bus controller	8 bits
H'FED1	ASTCR	AST7	AST6	AST5	AST4	AST3	AST2	AST1	AST0		
H'FED2	WCRH	W71	W70	W61	W60	W51	W50	W41	W40		
H'FED3	WCRL	W31	W30	W21	W20	W11	W10	W01	W00		
H'FED4	BCRH	ICIS1	ICIS0	BRSTRM	BRSTS1	BRSTS0	—	—	—		
H'FED5	BCRL	BRLE	BREQOE	EAE	—	—	—	—	WAITE		
H'FEDB	RAMER ^{*2}	—	—	—	—	RAMS	RAM2	RAM1	RAM0	Flash memory	8 bits
H'FF2C	ISCRH	IRQ7SCB	IRQ7SCA	IRQ6SCB	IRQ6SCA	IRQ5SCB	IRQ5SCA	IRQ4SCB	IRQ4SCA	Interrupt controller	8 bits
H'FF2D	ISCR L	IRQ3SCB	IRQ3SCA	IRQ2SCB	IRQ2SCA	IRQ1SCB	IRQ1SCA	IRQ0SCB	IRQ0SCA		
H'FF2E	IER	IRQ7E	IRQ6E	IRQ5E	IRQ4E	IRQ3E	IRQ2E	IRQ1E	IRQ0E		
H'FF2F	ISR	IRQ7F	IRQ6F	IRQ5F	IRQ4F	IRQ3F	IRQ2F	IRQ1F	IRQ0F		
H'FF30 to H'FF34	DTCE R	DTCE7	DTCE6	DTCE5	DTCE4	DTCE3	DTCE2	DTCE1	DTCE0	DTC	8 bits
H'FF37	DTVECR	SWDTE	DTVEC6	DTVEC5	DTVEC4	DTVEC3	DTVEC2	DTVEC1	DTVEC0		
H'FF38	SBYCR	SSBY	STS2	STS1	STS0	OPE	—	—	IRQ37S	Power-down mode	8 bits
H'FF39	SYSCR	—	—	INTM1	INTM0	NMIEG	LWROD	—	RAME	MCU	8 bits
H'FF3A	SCKCR	PSTOP	—	DIV	—	—	SCK2	SCK1	SCK0	Clock pulse generator	8 bits
H'FF3B	MDCR	—	—	—	—	—	MDS2	MDS1	MDS0	MCU	8 bits
H'FF3C	MSTPCR H	MSTP15	MSTP14	MSTP13	MSTP12	MSTP11	MSTP10	MSTP9	MSTP8	Power-down mode	8 bits
H'FF3D	MSTPCR L	MSTP7	MSTP6	MSTP5	MSTP4	MSTP3	MSTP2	MSTP1	MSTP0		

Address	Register Name	Bit 7	Bit 6	Bit 5	Bit 4	Bit 3	Bit 2	Bit 1	Bit 0	Module Name	Data Bus Width
H'FF42	SYSCR2 ^{*3}	—	—	—	—	FLSHE	—	—	—	Flash memory	8 bits
H'FF44	Reserved	—	—	—	—	—	—	—	—	Reserved	—
H'FF45	PF0CR1	CSS17	CSS36	PF1CS5S	PF0CS4S	A23E	A22E	A21E	A20E	Ports	8 bits
H'FF50	PORT1	P17	P16	P15	P14	P13	P12	P11	P10		
H'FF51	PORT2	P27	P26	P25	P24	P23	P22	P21	P20		
H'FF52	PORT3	—	—	P35	P34	P33	P32	P31	P30		
H'FF53	PORT4	P47	P46	P45	P44	P43	P42	P41	P40		
H'FF59	PORTA	—	—	—	—	PA3	PA2	PA1	PA0		
H'FF5A	PORTB	PB7	PB6	PB5	PB4	PB3	PB2	PB1	PB0		
H'FF5B	PORTC	PC7	PC6	PC5	PC4	PC3	PC2	PC1	PC0		
H'FF5C	PORTD	PD7	PD6	PD5	PD4	PD3	PD2	PD1	PD0		
H'FF5D	PORTE	PE7	PE6	PE5	PE4	PE3	PE2	PE1	PE0		
H'FF5E	PORTF	PF7	PF6	PF5	PF4	PF3	PF2	PF1	PF0		
H'FF5F	PORTG	—	—	—	PG4	PG3	PG2	PG1	PG0		
H'FF60	P1DR	P17DR	P16DR	P15DR	P14DR	P13DR	P12DR	P11DR	P10DR		
H'FF61	P2DR	P27DR	P26DR	P25DR	P24DR	P23DR	P22DR	P21DR	P20DR		
H'FF62	P3DR	—	—	P35DR	P34DR	P33DR	P32DR	P31DR	P30DR		
H'FF69	PADR	—	—	—	—	PA3DR	PA2DR	PA1DR	PA0DR		
H'FF6A	PBDR	PB7DR	PB6DR	PB5DR	PB4DR	PB3DR	PB2DR	PB1DR	PB0DR		
H'FF6B	PCDR	PC7DR	PC6DR	PC5DR	PC4DR	PC3DR	PC2DR	PC1DR	PC0DR		
H'FF6C	PDDR	PD7DR	PD6DR	PD5DR	PD4DR	PD3DR	PD2DR	PD1DR	PD0DR		
H'FF6D	PEDR	PE7DR	PE6DR	PE5DR	PE4DR	PE3DR	PE2DR	PE1DR	PE0DR		
H'FF6E	PFDR	PF7DR	PF6DR	PF5DR	PF4DR	PF3DR	PF2DR	PF1DR	PF0DR		
H'FF6F	PGDR	—	—	—	PG4DR	PG3DR	PG2DR	PG1DR	PG0DR		
H'FF70	PAPCR	—	—	—	—	PA3PCR	PA2PCR	PA1PCR	PA0PCR		
H'FF71	PBPCR	PB7PCR	PB6PCR	PB5PCR	PB4PCR	PB3PCR	PB2PCR	PB1PCR	PB0PCR		
H'FF72	PCPCR	PC7PCR	PC6PCR	PC5PCR	PC4PCR	PC3PCR	PC2PCR	PC1PCR	PC0PCR		
H'FF73	PDPCR	PD7PCR	PD6PCR	PD5PCR	PD4PCR	PD3PCR	PD2PCR	PD1PCR	PD0PCR		
H'FF74	PEPCR	PE7PCR	PE6PCR	PE5PCR	PE4PCR	PE3PCR	PE2PCR	PE1PCR	PE0PCR		
H'FF76	P3ODR	—	—	P35ODR	P34ODR	P33ODR	P32ODR	P31ODR	P30ODR		
H'FF77	PAODR	—	—	—	—	PA3ODR	PA2ODR	PA1ODR	PA0ODR		

Appendix B Internal I/O Registers

Address	Register Name	Bit 7	Bit 6	Bit 5	Bit 4	Bit 3	Bit 2	Bit 1	Bit 0	Module Name	Data Bus Width
H'FF78	SMR0	C/ \bar{A} / GM ^{*3}	CHR/ BLK ^{*4}	PE	O/ \bar{E}	STOP/ BCP1 ^{*5}	MP/ BCP0 ^{*6}	CKS1	CKS0	SCI0, smart card interface 0	8 bits
H'FF79	BRR0										
H'FF7A	SCR0	TIE	RIE	TE	RE	MPIE	TEIE	CKE1	CKE0		
H'FF7B	TDR0										
H'FF7C	SSR0	TDRE	RDRF	ORER	FER/ ERS ^{*7}	PER	TEND	MPB	MPBT		
H'FF7D	RDR0										
H'FF7E	SCMR0	—	—	—	—	SDIR	SINV	—	SMIF		
H'FF80	SMR1	C/ \bar{A} / GM ^{*4}	CHR/ BLK ^{*5}	PE	O/ \bar{E}	STOP/ BCP1 ^{*6}	MP/ BCP0 ^{*7}	CKS1	CKS0	SCI1, smart card interface 1	8 bits
H'FF81	BRR1										
H'FF82	SCR1	TIE	RIE	TE	RE	MPIE	TEIE	CKE1	CKE0		
H'FF83	TDR1										
H'FF84	SSR1	TDRE	RDRF	ORER	FER/ ERS ^{*8}	PER	TEND	MPB	MPBT		
H'FF85	RDR1										
H'FF86	SCMR1	—	—	—	—	SDIR	SINV	—	SMIF		
H'FE90	ADDRAH	AD9	AD8	AD7	AD6	AD5	AD4	AD3	AD2	A/D converter	8 bits
H'FE91	ADDRAL	AD1	AD0	—	—	—	—	—	—		
H'FE92	ADDRBH	AD9	AD8	AD7	AD6	AD5	AD4	AD3	AD2		
H'FE93	ADDRBL	AD1	AD0	—	—	—	—	—	—		
H'FE94	ADDRCH	AD9	AD8	AD7	AD6	AD5	AD4	AD3	AD2		
H'FE95	ADDRCL	AD1	AD0	—	—	—	—	—	—		
H'FE96	ADDRDH	AD9	AD8	AD7	AD6	AD5	AD4	AD3	AD2		
H'FE97	ADDRDL	AD1	AD0	—	—	—	—	—	—		
H'FE98	ADCSR	ADF	ADIE	ADST	SCAN	CKS	CH2	CH1	CH0		
H'FE99	ADCR	TRGS1	TRGS0	—	—	CKS1	—	—	—		

Address	Register Name	Bit 7	Bit 6	Bit 5	Bit 4	Bit 3	Bit 2	Bit 1	Bit 0	Module Name	Data Bus Width
H'FFA4	DADR0									D/A converter	8 bits
H'FFA5	DADR1										
H'FFA6	DACR01	DAOE1	DAOE0	DAE	—	—	—	—	—		
H'FFAC	PFCR2	—	—	CS167E	CS25E	ASOD	—	—	—	Ports	8 bits
H'FFB0	TCR0	CMIEB	CMIEA	OVIE	CCLR1	CCLR0	CKS2	CKS1	CKS0	8-bit timer channel 0, 1	16 bits
H'FFB1	TCR1	CMIEB	CMIEA	OVIE	CCLR1	CCLR0	CKS2	CKS1	CKS0		
H'FFB2	TCSR0	CMFB	CMFA	OVF	ADTE	OS3	OS2	OS1	OS0		
H'FFB3	TCSR1	CMFB	CMFA	OVF	—	OS3	OS2	OS1	OS0		
H'FFB4	TCORA0										
H'FFB5	TCORA1										
H'FFB6	TCORB0										
H'FFB7	TCORB1										
H'FFB8	TCNT0										
H'FFB9	TCNT1										
H'FFBC (Read)	TCSR	OVF	WT/IT	TME	—	—	CKS2	CKS1	CKS0	WDT	16 bits
H'FFBD (Read)	TCNT										
H'FFBF (Read)	RSTCSR	WOVF	RSTE	—	—	—	—	—	—		
H'FFC0	TSTR	—	—	CST5	CST4	CST3	CST2	CST1	CST0	TPU	16 bits
H'FFC1	TSYR	—	—	SYNC5	SYNC4	SYNC3	SYNC2	SYNC1	SYNC0		

Appendix B Internal I/O Registers

Address	Register Name	Bit 7	Bit 6	Bit 5	Bit 4	Bit 3	Bit 2	Bit 1	Bit 0	Module Name	Data Bus Width
H'FFC8 ^{*9}	FLMCR1	FWE	SWE	ESU	PSU	EV	PV	E	P	Flash memory (H8S/2317 F-ZTAT)	8 bits
H'FFC9 ^{*9}	FLMCR2	FLER	—	—	—	—	—	—	—		
H'FFCA ^{*9}	EBR1	EB7	EB6	EB5	EB4	EB3	EB2	EB1	EB0		
H'FFCB ^{*9}	EBR2	—	—	—	—	—	—	EB9	EB8		
H'FFC8 ^{*10}	FLMCR1	FWE	SWE	ESU	PSU	EV	PV	E	P	Flash memory (H8S/2318 F-ZTAT)	8 bits
H'FFC9 ^{*10}	FLMCR2	FLER	—	—	—	—	—	—	—		
H'FFCA ^{*10}	EBR1	EB7	EB6	EB5	EB4	EB3	EB2	EB1	EB0		
H'FFCB ^{*10}	EBR2	—	—	—	—	EB11	EB10	EB9	EB8		
H'FFC8 ^{*11}	FLMCR1	FWE	SWE	ESU	PSU	EV	PV	E	P	Flash memory (H8S/2315 F-ZTAT, H8S/2314 F-ZTAT)	8 bits
H'FFC9 ^{*11}	FLMCR2	FLER	—	—	—	—	—	—	—		
H'FFCA ^{*11}	EBR1	EB7	EB6	EB5	EB4	EB3	EB2	EB1	EB0		
H'FFCB ^{*11}	EBR2	—	—	EB13	EB12	EB11	EB10	EB9	EB8		
H'FFC8 ^{*12}	FLMCR1	FWE	SWE1	ESU1	PSU1	EV1	PV1	E1	P1	Flash memory (H8S/2319 F-ZTAT)	8 bits
H'FFC9 ^{*12}	FLMCR2	FLER	SWE2	ESU2	PSU2	EV2	PV2	E2	P2		
H'FFCA ^{*12}	EBR1	EB7	EB6	EB5	EB4	EB3	EB2	EB1	EB0		
H'FFCB ^{*12}	EBR2	EB15	EB14	EB13	EB12	EB11	EB10	EB9	EB8		
H'FFC4 ^{*13}	FCCS	—	—	—	—	—	—	—	SCO	Flash memory (H8S/2319C F-ZTAT)	8 bits
H'FFC5 ^{*13}	FPCS	—	—	—	—	—	—	—	PPVS		
H'FFC6 ^{*13}	FECS	—	—	—	—	—	—	—	EPVB		
H'FFC7 ^{*13}	Reserved	—	—	—	—	—	—	—	—		
H'FFC8 ^{*13}	FKEY	K7	K6	K5	K4	K3	K2	K1	K0	16 bits	
H'FFC9 ^{*13}	FMATS	MS7	MS6	MS5	MS4	MS3	MS2	MS1	MS0		
H'FFCA ^{*13}	FTDAR	TDER	TDA6	TDA5	TDA4	TDA3	TDA2	TDA1	TDA0		
H'FFCB ^{*13}	Reserved	—	—	—	—	—	—	—	—		
H'FFCC ^{*13}	Reserved	—	—	—	—	—	—	—	—		
H'FFCD ^{*13}	Reserved	—	—	—	—	—	—	—	—		
H'FFCE ^{*13}	Reserved	—	—	—	—	—	—	—	—		
H'FFCF ^{*13}	Reserved	—	—	—	—	—	—	—	—		

Address	Register Name	Bit 7	Bit 6	Bit 5	Bit 4	Bit 3	Bit 2	Bit 1	Bit 0	Module Name	Data Bus Width
H'FFD0	TCR0	CCLR2	CCLR1	CCLR0	CKEG1	CKEG0	TPSC2	TPSC1	TPSC0	TPU0	16 bits
H'FFD1	TMDR0	—	—	BFB	BFA	MD3	MD2	MD1	MD0		
H'FFD2	TIOR0H	IOB3	IOB2	IOB1	IOB0	IOA3	IOA2	IOA1	IOA0		
H'FFD3	TIOR0L	IOD3	IOD2	IOD1	IOD0	IOC3	IOC2	IOC1	IOC0		
H'FFD4	TIER0	TTGE	—	—	TCIEV	TGIED	TGIEC	TGIEB	TGIEA		
H'FFD5	TSR0	—	—	—	TCFV	TGFD	TGFC	TGFB	TGFA		
H'FFD6	TCNT0										
H'FFD7											
H'FFD8	TGR0A										
H'FFD9											
H'FFDA	TGR0B										
H'FFDB											
H'FFDC	TGR0C										
H'FFDD											
H'FFDE	TGR0D										
H'FFDF											
H'FFE0	TCR1	—	CCLR1	CCLR0	CKEG1	CKEG0	TPSC2	TPSC1	TPSC0	TPU1	16 bits
H'FFE1	TMDR1	—	—	—	—	MD3	MD2	MD1	MD0		
H'FFE2	TIOR1	IOB3	IOB2	IOB1	IOB0	IOA3	IOA2	IOA1	IOA0		
H'FFE4	TIER1	TTGE	—	TCIEU	TCIEV	—	—	TGIEB	TGIEA		
H'FFE5	TSR1	TCFD	—	TCFU	TCFV	—	—	TGFB	TGFA		
H'FFE6	TCNT1										
H'FFE7											
H'FFE8	TGR1A										
H'FFE9											
H'FFEA	TGR1B										
H'FFEB											

Address	Register Name	Bit 7	Bit 6	Bit 5	Bit 4	Bit 3	Bit 2	Bit 1	Bit 0	Module Name	Data Bus Width
H'FFF0	TCR2	—	CCLR1	CCLR0	CKEG1	CKEG0	TPSC2	TPSC1	TPSC0	TPU2	16 bits
H'FFF1	TMDR2	—	—	—	—	MD3	MD2	MD1	MD0		
H'FFF2	TIOR2	IOB3	IOB2	IOB1	IOB0	IOA3	IOA2	IOA1	IOA0		
H'FFF4	TIER2	TTGE	—	TCIEU	TCIEV	—	—	TGIEB	TGIEA		
H'FFF5	TSR2	TCFD	—	TCFU	TCFV	—	—	TGFB	TGFA		
H'FFF6	TCNT2										
H'FFF7											
H'FFF8	TGR2A										
H'FFF9											
H'FFFA	TGR2B										
H'FFFB											

- Notes:
1. Located in on-chip RAM. The bus width is 32 bits when the DTC accesses this area as register information, and 16 bits otherwise.
 2. Valid only in the F-ZTAT versions but the H8S/2314 F-ZTAT. In the H8S/2314 F-ZTAT, this cannot be used and must not be accessed.
 3. Valid only in the F-ZTAT versions.
 4. Functions as C/\bar{A} for SCI use, and as GM for smart card interface use.
 5. Functions as CHR for SCI use, and as BLK for smart card interface use.
 6. Functions as STOP for SCI use, and as BCP1 for smart card interface use.
 7. Functions as MP for SCI use, and as BCP0 for smart card interface use.
 8. Functions as FER for SCI use, and as ERS for smart card interface use.
 9. Valid in the H8S/2317 F-ZTAT only.
 10. Valid in the H8S/2318 F-ZTAT only.
 11. Valid in the H8S/2315 F-ZTAT, H8S/2314 F-ZTAT only.
 12. Valid in the H8S/2319 F-ZTAT only.
 13. Valid in the H8S/2319C F-ZTAT only.

B.2 List of Registers (By Module)

Module	Register	Abbreviation	R/W	Initial Value	Address*1
Interrupt controller	System control register	SYSCR	R/W	H'01	H'FF39
	IRQ sense control register H	ISCRH	R/W	H'00	H'FF2C
	IRQ sense control register L	ISCR L	R/W	H'00	H'FF2D
	IRQ enable register	IER	R/W	H'00	H'FF2E
	IRQ status register	ISR	R/(W)*2	H'00	H'FF2F
	Interrupt priority register A	IPRA	R/W	H'77	H'FEC4
	Interrupt priority register B	IPRB	R/W	H'77	H'FEC5
	Interrupt priority register C	IPRC	R/W	H'77	H'FEC6
	Interrupt priority register D	IPRD	R/W	H'77	H'FEC7
	Interrupt priority register E	IPRE	R/W	H'77	H'FEC8
	Interrupt priority register F	IPRF	R/W	H'77	H'FEC9
	Interrupt priority register G	IPRG	R/W	H'77	H'FECA
	Interrupt priority register H	IPRH	R/W	H'77	H'FECB
	Interrupt priority register I	IPRI	R/W	H'77	H'FECC
Interrupt priority register J	IPRJ	R/W	H'77	H'FECD	
Interrupt priority register K	IPRK	R/W	H'77	H'FECE	
DTC	DTC mode register A	MRA	—*3	Undefined	—*4
	DTC mode register B	MRB	—*3	Undefined	—*4
	DTC source address register	SAR	—*3	Undefined	—*4
	DTC destination address register	DAR	—*3	Undefined	—*4
	DTC transfer count register A	CRA	—*3	Undefined	—*4
	DTC transfer count register B	CRB	—*3	Undefined	—*4
	DTC enable register	DT CER	R/W	H'00	H'FF30 to H'FF34
	DTC vector register	DTVECR	R/W	H'00	H'FF37
Module stop control register	MSTPCR	R/W	H'3FFF	H'FF3C	

Module	Register	Abbreviation	R/W	Initial Value	Address*1
Bus controller	Bus width control register	ABWCR	R/W	H'FF/H'00*5	H'FED0
	Access state control register	ASTCR	R/W	H'FF	H'FED1
	Wait control register H	WCRH	R/W	H'FF	H'FED2
	Wait control register L	WCRL	R/W	H'FF	H'FED3
	Bus control register H	BCRH	R/W	H'D0	H'FED4
	Bus control register L	BCRL	R/W	H'3C	H'FED5
8-bit timer 0	Timer control register 0	TCR0	R/W	H'00	H'FFB0
	Timer control/status register 0	TCSR0	R/(W)*7	H'00	H'FFB2
	Timer constant register A0	TCORA0	R/W	H'FF	H'FFB4
	Timer constant register B0	TCORB0	R/W	H'FF	H'FFB6
	Timer counter 0	TCNT0	R/W	H'00	H'FFB8
8-bit timer 1	Timer control register 1	TCR1	R/W	H'00	H'FFB1
	Timer control/status register 1	TCSR1	R/(W)*7	H'10	H'FFB3
	Timer constant register A1	TCORA1	R/W	H'FF	H'FFB5
	Timer constant register B1	TCORB1	R/W	H'FF	H'FFB7
	Timer counter 1	TCNT1	R/W	H'00	H'FFB9
All 8-bit timer channels	Module stop control register	MSTPCR	R/W	H'3FFF	H'FF3C
WDT	Timer control/status register	TCSR	R/(W)*9	H'18	H'FFBC: Write*8 H'FFBC: Read
	Timer counter	TCNT	R/W	H'00	H'FFBC: Write*6 H'FFBD: Read
	Reset control/status register	RSTCSR	R/(W)*9	H'1F	H'FFBE: Write*8 H'FFBF: Read

Module	Register	Abbreviation	R/W	Initial Value	Address*1
SCI0	Serial mode register 0	SMR0	R/W	H'00	H'FF78
	Bit rate register 0	BRR0	R/W	H'FF	H'FF79
	Serial control register 0	SCR0	R/W	H'00	H'FF7A
	Transmit data register 0	TDR0	R/W	H'FF	H'FF7B
	Serial status register 0	SSR0	R/(W)*2	H'84	H'FF7C
	Receive data register 0	RDR0	R	H'00	H'FF7D
	Smart card mode register 0	SCMR0	R/W	H'F2	H'FF7E
SCI1	Serial mode register 1	SMR1	R/W	H'00	H'FF80
	Bit rate register 1	BRR1	R/W	H'FF	H'FF81
	Serial control register 1	SCR1	R/W	H'00	H'FF82
	Transmit data register 1	TDR1	R/W	H'FF	H'FF83
	Serial status register 1	SSR1	R/(W)*2	H'84	H'FF84
	Receive data register 1	RDR1	R	H'00	H'FF85
	Smart card mode register 1	SCMR1	R/W	H'F2	H'FF86
All SCI channels	Module stop control register	MSTPCR	R/W	H'3FFF	H'FF3C
SMCI0	Serial mode register 0	SMR0	R/W	H'00	H'FF78
	Bit rate register 0	BRR0	R/W	H'FF	H'FF79
	Serial control register 0	SCR0	R/W	H'00	H'FF7A
	Transmit data register 0	TDR0	R/W	H'FF	H'FF7B
	Serial status register 0	SSR0	R/(W)*2	H'84	H'FF7C
	Receive data register 0	RDR0	R	H'00	H'FF7D
	Smart card mode register 0	SCMR0	R/W	H'F2	H'FF7E
SMCI1	Serial mode register 1	SMR1	R/W	H'00	H'FF80
	Bit rate register 1	BRR1	R/W	H'FF	H'FF81
	Serial control register 1	SCR1	R/W	H'00	H'FF82
	Transmit data register 1	TDR1	R/W	H'FF	H'FF83
	Serial status register 1	SSR1	R/(W)*2	H'84	H'FF84
	Receive data register 1	RDR1	R	H'00	H'FF85
	Smart card mode register 1	SCMR1	R/W	H'F2	H'FF86

Module	Register	Abbreviation	R/W	Initial Value	Address*1
All SMC1 channels	Module stop control register	MSTPCR	R/W	H'3FFF	H'FF3C
ADC	A/D data register AH	ADDRAH	R	H'00	H'FF90
	A/D data register AL	ADDRAL	R	H'00	H'FF91
	A/D data register BH	ADDRBH	R	H'00	H'FF92
	A/D data register BL	ADDRBL	R	H'00	H'FF93
	A/D data register CH	ADDRCH	R	H'00	H'FF94
	A/D data register CL	ADDRCL	R	H'00	H'FF95
	A/D data register DH	ADDRDH	R	H'00	H'FF96
	A/D data register DL	ADDRDL	R	H'00	H'FF97
	A/D control/status register	ADCSR	R/(W) ^{*9}	H'00	H'FF98
	A/D control register	ADCR	R/W	H'3F	H'FF99
	Module stop control register	MSTPCR	R/W	H'3FFF	H'FF3C
DAC0, 1	D/A data register 0	DADR0	R/W	H'00	H'FFA4
	D/A data register 1	DADR1	R/W	H'00	H'FFA5
	D/A control register 01	DACR01	R/W	H'1F	H'FFA6
All DAC channels	Module stop control register	MSTPCR	R/W	H'3FFF	H'FF3C
On-chip RAM	System control register	SYSCR	R/W	H'01	H'FF39
TPU0	Timer control register 0	TCR0	R/W	H'00	H'FFD0
	Timer mode register 0	TMDR0	R/W	H'C0	H'FFD1
	Timer I/O control register 0H	TIOR0H	R/W	H'00	H'FFD2
	Timer I/O control register 0L	TIOR0L	R/W	H'00	H'FFD3
	Timer interrupt enable register 0	TIER0	R/W	H'40	H'FFD4
	Timer status register 0	TSR0	R/(W) ^{*2}	H'C0	H'FFD5
	Timer counter 0	TCNT0	R/W	H'0000	H'FFD6
	Timer general register 0A	TGR0A	R/W	H'FFFF	H'FFD8
	Timer general register 0B	TGR0B	R/W	H'FFFF	H'FFDA
	Timer general register 0C	TGR0C	R/W	H'FFFF	H'FFDC
	Timer general register 0D	TGR0D	R/W	H'FFFF	H'FFDE
TPU1	Timer control register 1	TCR1	R/W	H'00	H'FFE0
	Timer mode register 1	TMDR1	R/W	H'C0	H'FFE1

Module	Register	Abbreviation	R/W	Initial Value	Address*1
TPU1	Timer I/O control register 1	TIOR1	R/W	H'00	H'FFE2
	Timer interrupt enable register 1	TIER1	R/W	H'40	H'FFE4
	Timer status register 1	TSR1	R/(W) *2	H'C0	H'FFE5
	Timer counter 1	TCNT1	R/W	H'0000	H'FFE6
	Timer general register 1A	TGR1A	R/W	H'FFFF	H'FFE8
	Timer general register 1B	TGR1B	R/W	H'FFFF	H'FFEA
TPU2	Timer control register 2	TCR2	R/W	H'00	H'FFF0
	Timer mode register 2	TMDR2	R/W	H'C0	H'FFF1
	Timer I/O control register 2	TIOR2	R/W	H'00	H'FFF2
	Timer interrupt enable register 2	TIER2	R/W	H'40	H'FFF4
	Timer status register 2	TSR2	R/(W) *2	H'C0	H'FFF5
	Timer counter 2	TCNT2	R/W	H'0000	H'FFF6
	Timer general register 2A	TGR2A	R/W	H'FFFF	H'FFF8
	Timer general register 2B	TGR2B	R/W	H'FFFF	H'FFFA
TPU3	Timer control register 3	TCR3	R/W	H'00	H'FE80
	Timer mode register 3	TMDR3	R/W	H'C0	H'FE81
	Timer I/O control register 3H	TIOR3H	R/W	H'00	H'FE82
	Timer I/O control register 3L	TIOR3L	R/W	H'00	H'FE83
	Timer interrupt enable register 3	TIER3	R/W	H'40	H'FE84
	Timer status register 3	TSR3	R/(W) *2	H'C0	H'FE85
	Timer counter 3	TCNT3	R/W	H'0000	H'FE86
	Timer general register 3A	TGR3A	R/W	H'FFFF	H'FE88
	Timer general register 3B	TGR3B	R/W	H'FFFF	H'FE8A
	Timer general register 3C	TGR3C	R/W	H'FFFF	H'FE8C
Timer general register 3D	TGR3D	R/W	H'FFFF	H'FE8E	
TPU4	Timer control register 4	TCR4	R/W	H'00	H'FE90
	Timer mode register 4	TMDR4	R/W	H'C0	H'FE91
	Timer I/O control register 4	TIOR4	R/W	H'00	H'FE92
	Timer interrupt enable register 4	TIER4	R/W	H'40	H'FE94
	Timer status register 4	TSR4	R/(W) *2	H'C0	H'FE95
	Timer counter 4	TCNT4	R/W	H'0000	H'FE96
	Timer general register 4A	TGR4A	R/W	H'FFFF	H'FE98
	Timer general register 4B	TGR4B	R/W	H'FFFF	H'FE9A

Module	Register	Abbreviation	R/W	Initial Value	Address*1
TPU5	Timer control register 5	TCR5	R/W	H'00	H'FEA0
	Timer mode register 5	TMDR5	R/W	H'C0	H'FEA1
	Timer I/O control register 5	TIOR5	R/W	H'00	H'FEA2
	Timer interrupt enable register 5	TIER5	R/W	H'40	H'FEA4
	Timer status register 5	TSR5	R/(W)*2	H'C0	H'FEA5
	Timer counter 5	TCNT5	R/W	H'0000	H'FEA6
	Timer general register 5A	TGR5A	R/W	H'FFFF	H'FEA8
	Timer general register 5B	TGR5B	R/W	H'FFFF	H'FEAA
All TPU channels	Timer start register	TSTR	R/W	H'00	H'FFC0
	Timer synchro register	TSYR	R/W	H'00	H'FFC1
	Module stop control register	MSTPCR	R/W	H'3FFF	H'FF3C
Flash memory	Flash memory control register 1	FLMCR1*14	R/W*11	H'00/H'80*12	H'FFC8*10
	Flash memory control register 2	FLMCR2*14	R/W*11	H'00	H'FFC9*10
	Erase block register 1	EBR1*14	R/W*11	H'00*13	H'FFCA*10
	Erase block register 2	EBR2*14	R/W*11	H'00*13	H'FFCB*10
	RAM emulation register	RAMER*19	R/W	H'00	H'FEDB
	System control register 2	SYSCR2*15	R/W	H'00	H'FF42
	Flash code control status register	FCCS*20	R/W	H'80	H'FFC4
	Flash program code select register	FPCS*20	R/W	H'00	H'FFC5
	Flash erase code select register	FECS*20	R/W	H'00	H'FFC6
	Flash key code register	FKEY*20	R/W	H'00	H'FFC8
	Flash MAT select register	FMATS*20	R/W	H'00/H'AA*21	H'FFC9
	Flash transfer destination address register	FTDAR*20	R/W	H'00	H'FFCA
Clock pulse generator	System clock control register	SCKCR	R/W	H'00	H'FF3A
MCU	System control register	SYSCR	R/W	H'01	H'FF39
	Mode control register	MDCR	R	Undefined	H'FF3B

Module	Register	Abbreviation	R/W	Initial Value	Address*1
Power-down state	Standby control register	SBYCR	R/W	H'08	H'FF38
	Module stop control register H	MSTPCRH	R/W	H'3F	H'FF3C
	Module stop control register L	MSTPCRL	R/W	H'FF	H'FF3D
Port 1	Port 1 data direction register	P1DDR	W	H'00	H'FEB0
	Port 1 data register	P1DR	R/W	H'00	H'FF60
	Port 1 register	PORT1	R	Undefined	H'FF50
	Port function control register 1	PFCR1	R/W	H'0F	H'FF45
Port 2	Port 2 data direction register	P2DDR	W	H'00	H'FEB1
	Port 2 data register	P2DR	R/W	H'00	H'FF61
	Port 2 register	PORT2	R	Undefined	H'FF51
Port 3	Port 3 data direction register	P3DDR	W	H'00	H'FEB2
	Port 3 data register	P3DR	R/W	H'00	H'FF62
	Port 3 register	PORT3	R	Undefined	H'FF52
	Port 3 open drain control register	P3ODR	R/W	H'00	H'FF76
Port 4	Port 4 register	PORT4	R	Undefined	H'FF53
Port A	Port A data direction register	PADDR	W	H'0* ¹⁶	H'FEB9
	Port A data register	PADR	R/W	H'0* ¹⁶	H'FF69
	Port A register	PORTA	R	Undefined* ¹⁶	H'FF59
	Port A MOS pull-up control register	PAPCR	R/W	H'0* ¹⁶	H'FF70
	Port A open drain control register	PAODR	R/W	H'0* ¹⁶	H'FF77
Port B	Port B data direction register	PBDDR	W	H'00	H'FEBA
	Port B data register	PBDR	R/W	H'00	H'FF6A
	Port B register	PORTB	R	Undefined	H'FF5A
	Port B MOS pull-up control register	PBPCR	R/W	H'00	H'FF71
Port C	Port C data direction register	PCDDR	W	H'00	H'FEBB
	Port C data register	PCDR	R/W	H'00	H'FF6B
	Port C register	PORTC	R	Undefined	H'FF5B
	Port C MOS pull-up control register	PCPCR	R/W	H'00	H'FF72
Port D	Port D data direction register	PDDDR	W	H'00	H'FEBC
	Port D data register	PDDR	R/W	H'00	H'FF6C
	Port D register	PORTD	R	Undefined	H'FF5C
	Port D MOS pull-up control register	PDPCR	R/W	H'00	H'FF73

Module	Register	Abbreviation	R/W	Initial Value	Address ^{*1}
Port E	Port E data direction register	PEDDR	W	H'00	H'FEBD
	Port E data register	PEDR	R/W	H'00	H'FF6D
	Port E register	PORTE	R	Undefined	H'FF5D
	Port E MOS pull-up control register	PEPCR	R/W	H'00	H'FF74
Port F	Port F data direction register	PFDDR	W	H'80/H'00 ^{*17}	H'FEBE
	Port F data register	PFDR	R/W	H'00	H'FF6E
	Port F register	PORTF	R	Undefined	H'FF5E
	Port function control register 1	PFCR1	R/W	H'0F	H'FF45
	Port function control register 2	PFCR2	R/W	H'30	H'FFAC
	System control register	SYSCR	R/W	H'01	H'FF39
Port G	Port G data direction register	PGDDR	W	H'10/H'00 ^{*17 *18}	H'FEBF
	Port G data register	PGDR	R/W	H'00 ^{*18}	H'FF6F
	Port G register	PORTG	R	Undefined ^{*18}	H'FF5F
	Port function control register 1	PFCR1	R/W	H'0F	H'FF45
	Port function control register 2	PFCR2	R/W	H'30	H'FFAC

- Notes:
- Lower 16 bits of the address.
 - Only 0 can be written for flag clearing.
 - Registers in the DTC cannot be read or written to directly.
 - Located as register information in on-chip RAM addresses H'EBC0 to H'EFBF. Cannot be located in external memory space. Do not clear the RAME bit in SYSCR to 0 when using the DTC.
 - Determined by the MCU operating mode.
 - Bits used for pulse output cannot be written to.
 - Only 0 can be written to bits 7 to 5, to clear the flags.
 - For information on writing, see section 11.2.4, Notes on Register Access.
 - Only 0 can be written to bit 7, to clear the flag.
 - Flash memory registers selection is performed by means of the FLSHE bit in system control register 2 (SYSCR2).
 - In modes in which the on-chip flash memory is disabled, a read will return H'00, and writes are invalid. Writes are also disabled when the FWE bit in FLMCR1 is cleared to 0 (except for the H8S/2319 F-ZTAT).
 - In the H8S/2318 F-ZTAT, H8S/2317 F-ZTAT, H8S/2315 F-ZTAT, and H8S/2314 F-ZTAT when a high level is input to the FWE pin, the initial value is H'80. In the H8S/2319 F-ZTAT, the initial value is H'80.
 - In the H8S/2318 F-ZTAT, H8S/2317 F-ZTAT, H8S/2315 F-ZTAT, and H8S/2314 F-ZTAT when a low level is input to the FWE pin, or if a high level is input but the SWE bit in FLMCR1 is not set, these registers are initialized to H'00.

In the H8S/2319 F-ZTAT, the EB11 to EB0 bits are initialized to 0 when the SWE1 bit is not set to 1, and the EB15 to EB12 bits are initialized to 0 when the SWE2 bit is not set to 1.

14. FLMCR1, FLMCR2, EBR1, and EBR2 are 8-bit registers. Only byte access can be used on these registers, with the access requiring two states (Applies to the F-ZTAT versions but the H8S/2319C F-ZTAT).
15. The SYSCR2 register can only be used in the F-ZTAT versions. In the mask ROM versions this register will return an undefined value if read, and cannot be written to.
16. Value of bits 3 to 0.
17. The initial value depends on the mode.
18. Value of bits 4 to 0.
19. Valid only in the F-ZTAT versions but the H8S/2314 F-ZTAT. In the H8S/2314 F-ZTAT, this cannot be used and must not be accessed.
20. This applies to the H8S/2319C F-ZTAT only. Access is possible when the on-chip flash memory is enabled.
21. The initial value after startup is H'00 in the user boot mode and user program mode. The initial value after startup in the user boot mode is H'AA.

B.3 Functions

MRA—DTC Mode Register A

H'F800—H'FBFF

DTC

Bit	:	7	6	5	4	3	2	1	0
		SM1	SM0	DM1	DM0	MD1	MD0	DTS	Sz
Initial value	:	Undefined	Undefined	Undefined	Undefined	Undefined	Undefined	Undefined	Undefined
Read/Write	:	—	—	—	—	—	—	—	—

DTC Data Transfer Size

0	Byte-size transfer
1	Word-size transfer

DTC Transfer Mode Select

0	Destination side is repeat area or block area
1	Source side is repeat area or block area

DTC Mode

0	0	Normal mode
	1	Repeat mode
1	0	Block transfer mode
	1	—

Destination Address Mode

0	—	DAR is fixed
1	0	DAR is incremented after a transfer (by +1 when Sz = 0; by +2 when Sz = 1)
	1	DAR is decremented after a transfer (by -1 when Sz = 0; by -2 when Sz = 1)

Source Address Mode

0	—	SAR is fixed
1	0	SAR is incremented after a transfer (by +1 when Sz = 0; by +2 when Sz = 1)
	1	SAR is decremented after a transfer (by -1 when Sz = 0; by -2 when Sz = 1)

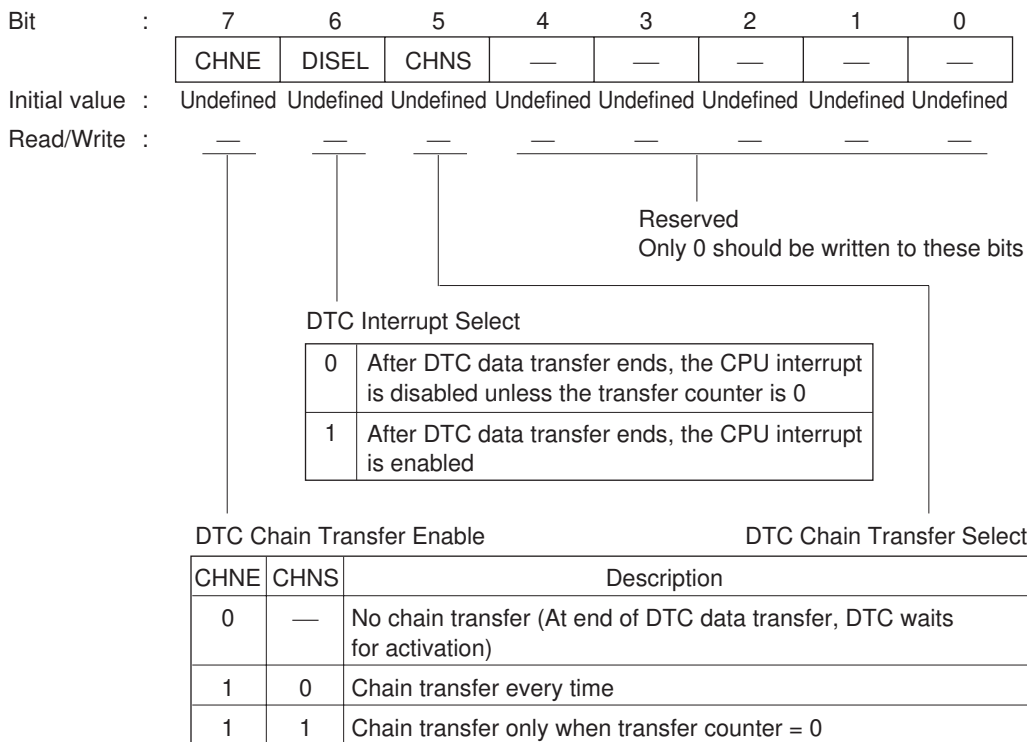
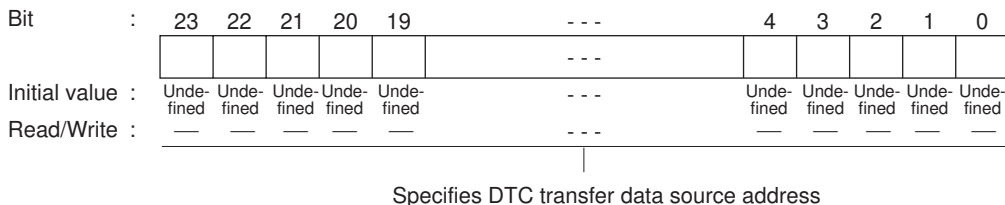
MRB—DTC Mode Register B**H'F800—H'FBFF****DTC****SAR—DTC Source Address Register****H'F800—H'FBFF****DTC**

DAR—DTC Destination Address Register

H'F800—H'FBFF

DTC

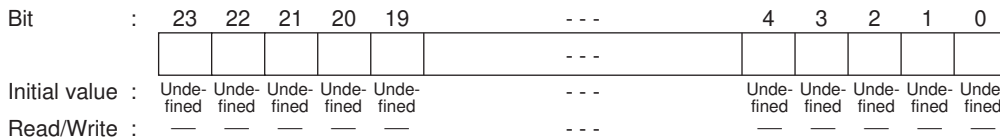

Specifies DTC transfer data destination address

CRA—DTC Transfer Count Register A

H'F800—H'FBFF

DTC

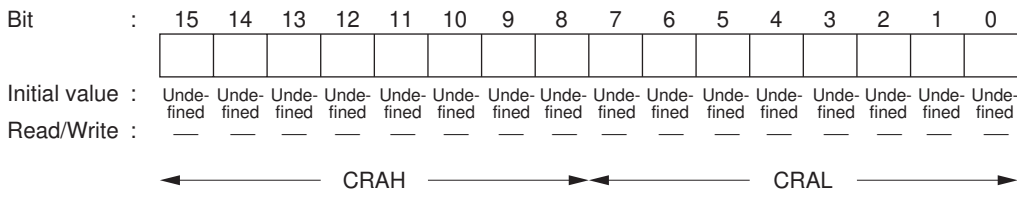

Specifies the number of DTC data transfers

CRB—DTC Transfer Count Register B

H'F800—H'FBFF

DTC

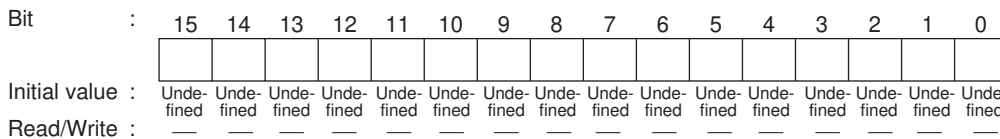

Specifies the number of DTC block data transfers

TCR3—Timer Control Register 3

H'FE80

TPU3

Bit	:	7	6	5	4	3	2	1	0
		CCLR2	CCLR1	CCLR0	CKEG1	CKEG0	TPSC2	TPSC1	TPSC0
Initial value	:	0	0	0	0	0	0	0	0
Read/Write	:	R/W	R/W	R/W	R/W	R/W	R/W	R/W	R/W

Timer Prescaler

0	0	0	Internal clock: counts on $\phi/1$
		1	Internal clock: counts on $\phi/4$
	1	0	Internal clock: counts on $\phi/16$
		1	Internal clock: counts on $\phi/64$
1	0	0	External clock: counts on TCLKA pin input
		1	Internal clock: counts on $\phi/1024$
	1	0	Internal clock: counts on $\phi/256$
		1	Internal clock: counts on $\phi/4096$

Clock Edge

0	0	Count at rising edge
	1	Count at falling edge
1	—	Count at both edges

Note: The internal clock edge selection is valid when the input clock is $\phi/4$ or slower. This setting is ignored if $\phi/1$ or overflow/underflow on another channel is selected as the input clock.

Counter Clear

0	0	0	TCNT clearing disabled
		1	TCNT cleared by TGRA compare match/input capture
	1	0	TCNT cleared by TGRB compare match/input capture
		1	TCNT cleared by counter clearing for another channel performing synchronous clearing/synchronous operation *1
1	0	0	TCNT clearing disabled
		1	TCNT cleared by TGRC compare match/input capture *2
	1	0	TCNT cleared by TGRD compare match/input capture *2
		1	TCNT cleared by counter clearing for another channel performing synchronous clearing/synchronous operation *1

- Notes: 1. Synchronous operation setting is performed by setting the SYNC bit in TSYR to 1.
 2. When TGRC or TGRD is used as a buffer register, TCNT is not cleared because the buffer register setting has priority, and compare match/input capture does not occur.

TMDR3—Timer Mode Register 3

H'FE81

TPU3

Bit	:	7	6	5	4	3	2	1	0
		—	—	BFB	BFA	MD3	MD2	MD1	MD0
Initial value	:	1	1	0	0	0	0	0	0
Read/Write	:	—	—	R/W	R/W	R/W	R/W	R/W	R/W

Mode

0	0	0	0	Normal operation
		1	Reserved	
	1	0	PWM mode 1	
		1	PWM mode 2	
	1	0	0	Phase counting mode 1
			1	Phase counting mode 2
		1	0	Phase counting mode 3
			1	Phase counting mode 4
1			—	

: Don't care

- Notes:
1. MD3 is a reserved bit. In a write, it should always be written with 0.
 2. Phase counting mode cannot be set for channels 0 and 3. In this case, 0 should always be written to MD2.

Buffer Operation A

0	TGRA operates normally
1	TGRA and TGRC used together for buffer operation

Buffer Operation B

0	TGRB operates normally
1	TGRB and TGRD used together for buffer operation

TIOR3H—Timer I/O Control Register 3H

H'FE82

TPU3

Bit	7	6	5	4	3	2	1	0
Initial value	IOB3	IOB2	IOB1	IOB0	IOA3	IOA2	IOA1	IOA0
	0	0	0	0	0	0	0	0
Read/Write	R/W	R/W	R/W	R/W	R/W	R/W	R/W	R/W

TGR3A I/O Control

0	0	0	0	TGR3A is output compare register	Output disabled			
					1	0	Initial output is 0 output	0 output at compare match
							1	Toggle output at compare match
	1	0	0		Output disabled			
					1	0	Initial output is 1 output	0 output at compare match
							1	Toggle output at compare match
1	0	0	0	TGR3A is input capture register	Input capture at rising edge			
					1	Input capture at falling edge		
					1	Input capture at both edges		
					1	Input capture at TCNT4 count-up/ count-down		

: Don't care

TGR3B I/O Control

0	0	0	TGR3B is output compare register	Output disabled				
				1	0	Initial output is 0 output	0 output at compare match	
						1	Toggle output at compare match	
	1	0		0	Output disabled			
					1	0	Initial output is 1 output	0 output at compare match
							1	Toggle output at compare match
1	0	0	0	TGR3B is input capture register	Input capture at rising edge			
					1	Input capture at falling edge		
					1	Input capture at both edges		
					1	Input capture at TCNT4 count-up/ count-down*		

: Don't care

Note: * When bits TPSC2 to TPSC0 in TCR4 are set to B'000, and $\phi/1$ is used as the TCNT4 count clock, this setting is invalid and input capture does not occur.

TIOR3L—Timer I/O Control Register 3L

H'FE83

TPU3

Bit	7	6	5	4	3	2	1	0
	IOD3	IOD2	IOD1	IOD0	IOC3	IOC2	IOC1	IOC0
Initial value :	0	0	0	0	0	0	0	0
Read/Write :	R/W	R/W	R/W	R/W	R/W	R/W	R/W	R/W

TGR3C I/O Control

0	0	0	0	TGR3C is output compare register*1	Output disabled				
					1	0	Initial output is 0 output	0 output at compare match	
							1 output at compare match	Toggle output at compare match	
		1	0		0	Output disabled			
						1	0	Initial output is 1 output	0 output at compare match
								1 output at compare match	Toggle output at compare match
	1	0	0	TGR3C is input capture register*	Capture input source is TIOCC3 pin	Input capture at rising edge			
					1	0	Input capture at falling edge	Input capture at both edges	
							1	0	Input capture at both edges
		1	0		0	Capture input source is channel 4/count clock	Input capture at TCNT4 count-up/count-down		
						1	0	Input capture at rising edge	Input capture at falling edge
								1 output at compare match	Toggle output at compare match

: Don't care

Note: * When the BFA bit in TMDR3 is set to 1 and TGR3C is used as a buffer register, this setting is invalid and input capture/output compare does not occur.

TGR3D I/O Control

0	0	0	TGR3D is output compare register*2	Output disabled					
				1	0	Initial output is 0 output	0 output at compare match		
						1 output at compare match	Toggle output at compare match		
		1		0	0	Output disabled			
						1	0	Initial output is 1 output	0 output at compare match
								1 output at compare match	Toggle output at compare match
	1	0	TGR3D is input capture register*2	Capture input source is TIOCC3 pin	Input capture at rising edge				
				1	0	Input capture at falling edge	Input capture at both edges		
						1	0	Input capture at both edges	
		1		0	0	Capture input source is channel 4/count clock	Input capture at TCNT4 count-up/count-down*1		
						1	0	Input capture at rising edge	Input capture at falling edge
								1 output at compare match	Toggle output at compare match

: Don't care

- Notes: 1. When bits TPSC2 to TPSC0 in TCR4 are set to B'000 and $\phi/1$ is used as the TCNT4 count clock, this setting is invalid and input capture does not occur.
2. When the BFB bit in TMDR3 is set to 1 and TGR3D is used as a buffer register, this setting is invalid and input capture/output compare does not occur.

Note: When TGRC or TGRD is designated for buffer operation, this setting is invalid and the register operates as a buffer register.

TIER3—Timer Interrupt Enable Register 3

H'FE84

TPU3

Bit	7	6	5	4	3	2	1	0
	TTGE	—	—	TCIEV	TGIED	TGIEC	TGIEB	TGIEA
Initial value :	0	1	0	0	0	0	0	0
Read/Write :	R/W	—	—	R/W	R/W	R/W	R/W	R/W

TGR Interrupt Enable A	
0	Interrupt request (TGIA) by TGFA bit disabled
1	Interrupt request (TGIA) by TGFA bit enabled

TGR Interrupt Enable B	
0	Interrupt request (TGIB) by TGFB bit disabled
1	Interrupt request (TGIB) by TGFB bit enabled

TGR Interrupt Enable C	
0	Interrupt request (TGIC) by TGFC bit disabled
1	Interrupt request (TGIC) by TGFC bit enabled

TGR Interrupt Enable D	
0	Interrupt request (TGID) by TGFD bit disabled
1	Interrupt request (TGID) by TGFD bit enabled

Overflow Interrupt Enable	
0	Interrupt request (TCIV) by TCFV disabled
1	Interrupt request (TCIV) by TCFV enabled

A/D Conversion Start Request Enable	
0	A/D conversion start request generation disabled
1	A/D conversion start request generation enabled

TSR3—Timer Status Register 3

H'FE85

TPU3

Bit	7	6	5	4	3	2	1	0
	—	—	—	TCFV	TGFD	TGFC	TGFB	TGFA
Initial value	1	1	0	0	0	0	0	0
Read/Write	—	—	—	R/(W)*	R/(W)*	R/(W)*	R/(W)*	R/(W)*

Input Capture/Output Compare Flag A

0	[Clearing conditions] <ul style="list-style-type: none"> When DTC is activated by TGIA interrupt while DISEL bit of MRB in DTC is 0 When 0 is written to TGFA after reading TGFA = 1
1	[Setting conditions] <ul style="list-style-type: none"> When TCNT=TGRA while TGRA is functioning as output compare register When TCNT value is transferred to TGRA by input capture signal while TGRA is functioning as input capture register

Input Capture/Output Compare Flag B

0	[Clearing conditions] <ul style="list-style-type: none"> When DTC is activated by TGIB interrupt while DISEL bit of MRB in DTC is 0 When 0 is written to TGFB after reading TGFB = 1
1	[Setting conditions] <ul style="list-style-type: none"> When TCNT = TGRB while TGRB is functioning as output compare register When TCNT value is transferred to TGRB by input capture signal while TGRB is functioning as input capture register

Input Capture/Output Compare Flag C

0	[Clearing conditions] <ul style="list-style-type: none"> When DTC is activated by TGIC interrupt while DISEL bit of MRB in DTC is 0 When 0 is written to TGFC after reading TGFC = 1
1	[Setting conditions] <ul style="list-style-type: none"> When TCNT = TGRC while TGRC is functioning as output compare register When TCNT value is transferred to TGRC by input capture signal while TGRC is functioning as input capture register

Input Capture/Output Compare Flag D

0	[Clearing conditions] <ul style="list-style-type: none"> When DTC is activated by TGID interrupt while DISEL bit of MRB in DTC is 0 When 0 is written to TGFD after reading TGFD = 1
1	[Setting conditions] <ul style="list-style-type: none"> When TCNT = TGRD while TGRD is functioning as output compare register When TCNT value is transferred to TGRD by input capture signal while TGRD is functioning as input capture register

Overflow Flag

0	[Clearing condition] <ul style="list-style-type: none"> When 0 is written to TCFV after reading TCFV = 1
1	[Setting condition] <ul style="list-style-type: none"> When the TCNT value overflows (changes from H'FFFF to H'0000)

Note: * Can only be written with 0 for flag clearing.

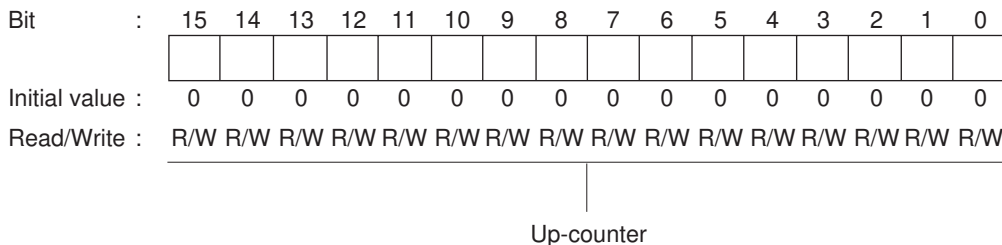
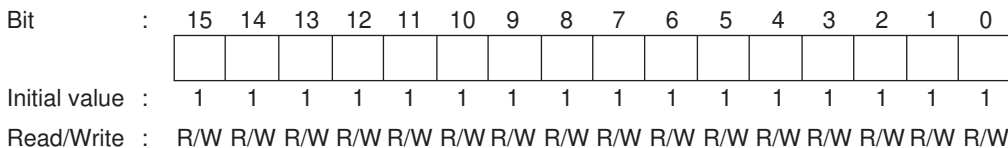
TCNT3—Timer Counter 3**H'FE86****TPU3****TGR3A—Timer General Register 3A****H'FE88****TPU3****TGR3B—Timer General Register 3B****H'FE8A****TPU3****TGR3C—Timer General Register 3C****H'FE8C****TPU3****TGR3D—Timer General Register 3D****H'FE8E****TPU3**

TCR4—Timer Control Register 4

H'FE90

TPU4

Bit	:	7	6	5	4	3	2	1	0
		—	CCLR1	CCLR0	CKEG1	CKEG0	TPSC2	TPSC1	TPSC0
Initial value	:	0	0	0	0	0	0	0	0
Read/Write	:	—	R/W	R/W	R/W	R/W	R/W	R/W	R/W

Timer Prescaler

0	0	0	Internal clock: counts on $\phi/1$
		1	Internal clock: counts on $\phi/4$
	1	0	Internal clock: counts on $\phi/16$
		1	Internal clock: counts on $\phi/64$
1	0	0	External clock: counts on TCLKA pin input
		1	External clock: counts on TCLKC pin input
	1	0	Internal clock: counts on $\phi/1024$
		1	Counts on TCNT5 overflow/underflow

Note: This setting is ignored when channel 4 is in phase counting mode.

Clock Edge

0	0	Count at rising edge
	1	Count at falling edge
1	—	Count at both edges

Note: This setting is ignored when channel 4 is in phase counting mode. The internal clock edge selection is valid when the input clock is $\phi/4$ or slower. This setting is ignored if $\phi/1$ or overflow/underflow on another channel is selected as the input clock.

Counter Clear

0	0	TCNT clearing disabled
	1	TCNT cleared by TGRA compare match/input capture
1	0	TCNT cleared by TGRB compare match/input capture
	1	TCNT cleared by counter clearing for another channel performing synchronous clearing/synchronous operation*

Note: * Synchronous operation setting is performed by setting the SYNC bit in TSYP to 1.

TMDR4—Timer Mode Register 4**H'FE91****TPU4**

Bit	:	7	6	5	4	3	2	1	0
		—	—	—	—	MD3	MD2	MD1	MD0
Initial value	:	1	1	0	0	0	0	0	0
Read/Write	:	—	—	—	—	R/W	R/W	R/W	R/W

Mode

0	0	0	0	Normal operation
			1	Reserved
		1	0	PWM mode 1
			1	PWM mode 2
	1	0	0	Phase counting mode 1
			1	Phase counting mode 2
		1	0	Phase counting mode 3
			1	Phase counting mode 4
1				—

: Don't care

Note: MD3 is a reserved bit. In a write, it should always be written with 0.

TIOR4—Timer I/O Control Register 4

H'FE92

TPU4

Bit	:	7	6	5	4	3	2	1	0
		IOB3	IOB2	IOB1	IOB0	IOA3	IOA2	IOA1	IOA0
Initial value :		0	0	0	0	0	0	0	0
Read/Write :		R/W	R/W	R/W	R/W	R/W	R/W	R/W	R/W

TGR4A I/O Control

0	0	0	0	TGR4A is output compare register	Output disabled				
					1	0	Initial output is 0 output	0 output at compare match	
							1 output at compare match		
		1	0		0	Toggle output at compare match			
						1	0	Output disabled	
								1	Initial output is 1 output
	1	0	0	1 output at compare match					
				1	0	Toggle output at compare match			
						1			
	1	0	0	0	TGR4A is input capture register	Capture input source is TIOCA4 pin	Input capture at rising edge		
						1	0	Input capture at falling edge	
								1	Input capture at both edges
1		0	0	0		Capture input source is TGR3A compare match/ input capture	Input capture at generation of TGR3A compare match/ input capture		
						1	0		
								1	

: Don't care

TGR4B I/O Control

0	0	0	0	TGR4B is output compare register	Output disabled				
					1	0	Initial output is 0 output	0 output at compare match	
							1 output at compare match		
		1	0		0	Toggle output at compare match			
						1	0	Output disabled	
								1	Initial output is 1 output
	1	0	0	1 output at compare match					
				1	0	Toggle output at compare match			
						1			
	1	0	0	0	TGR4B is input capture register	Capture input source is TIOCB4 pin	Input capture at rising edge		
						1	0	Input capture at falling edge	
								1	Input capture at both edges
1		0	0	0		Capture input source is TGR3C compare match/ input capture	Input capture at generation of TGR3C compare match/ input capture		
						1	0		
								1	

: Don't care

TIER4—Timer Interrupt Enable Register 4**H'FE94****TPU4**

Bit	7	6	5	4	3	2	1	0
	TTGE	—	TCIEU	TCIEV	—	—	TGIEB	TGIEA
Initial value :	0	1	0	0	0	0	0	0
Read/Write :	R/W	—	R/W	R/W	—	—	R/W	R/W

TGR Interrupt Enable A	
0	Interrupt request (TGIA) by TGFA bit disabled
1	Interrupt request (TGIA) by TGFA bit enabled

TGR Interrupt Enable B	
0	Interrupt request (TGIB) by TGFB bit disabled
1	Interrupt request (TGIB) by TGFB bit enabled

Overflow Interrupt Enable	
0	Interrupt request (TCIV) by TCFV disabled
1	Interrupt request (TCIV) by TCFV enabled

Underflow Interrupt Enable	
0	Interrupt request (TCIU) by TCFU disabled
1	Interrupt request (TCIU) by TCFU enabled

A/D Conversion Start Request Enable	
0	A/D conversion start request generation disabled
1	A/D conversion start request generation enabled

TSR4—Timer Status Register 4

H'FE95

TPU4

Bit	7	6	5	4	3	2	1	0
	TCFD	—	TCFU	TCFV	—	—	TGFB	TGFA
Initial value	1	1	0	0	0	0	0	0
Read/Write	R	—	R/(W)*	R/(W)*	—	—	R/(W)*	R/(W)*

Input Capture/Output Compare Flag A

0	[Clearing conditions] <ul style="list-style-type: none"> When DTC is activated by TGIA interrupt while DISEL bit of MRB in DTC is 0 When 0 is written to TGFA after reading TGFA = 1
1	[Setting conditions] <ul style="list-style-type: none"> When TCNT = TGRA while TGRA is functioning as output compare register When TCNT value is transferred to TGRA by input capture signal while TGRA is functioning as input capture register

Input Capture/Output Compare Flag B

0	[Clearing conditions] <ul style="list-style-type: none"> When DTC is activated by TGB interrupt while DISEL bit of MRB in DTC is 0 When 0 is written to TGFB after reading TGFB = 1
1	[Setting conditions] <ul style="list-style-type: none"> When TCNT = TGRB while TGRB is functioning as output compare register When TCNT value is transferred to TGRB by input capture signal while TGRB is functioning as input capture register

Overflow Flag

0	[Clearing condition] When 0 is written to TCFV after reading TCFV = 1
1	[Setting condition] When the TCNT value overflows (changes from H'FFFF to H'0000)

Underflow Flag

0	[Clearing condition] When 0 is written to TCFU after reading TCFU = 1
1	[Setting condition] When the TCNT value underflows (changes from H'0000 to H'FFFF)

Count Direction Flag

0	TCNT counts down
1	TCNT counts up

Note: * Can only be written with 0 for flag clearing.

TCNT4—Timer Counter 4**H'FE96****TPU4**

Bit	:	15	14	13	12	11	10	9	8	7	6	5	4	3	2	1	0
		<input type="checkbox"/>	<input type="checkbox"/>	<input type="checkbox"/>	<input type="checkbox"/>	<input type="checkbox"/>	<input type="checkbox"/>	<input type="checkbox"/>	<input type="checkbox"/>	<input type="checkbox"/>	<input type="checkbox"/>	<input type="checkbox"/>	<input type="checkbox"/>	<input type="checkbox"/>	<input type="checkbox"/>	<input type="checkbox"/>	<input type="checkbox"/>
Initial value	:	0	0	0	0	0	0	0	0	0	0	0	0	0	0	0	0
Read/Write	:	R/W	R/W	R/W	R/W	R/W	R/W	R/W	R/W	R/W	R/W	R/W	R/W	R/W	R/W	R/W	R/W
		<hr/> Up/down-counter*															

Note: * This timer counter can be used as an up/down-counter only in phase counting mode or when performing overflow/underflow counting on another channel. In other cases it functions as an up-counter.

TGR4A—Timer General Register 4A**H'FE98****TPU4****TGR4B—Timer General Register 4B****H'FE9A****TPU4**

Bit	:	15	14	13	12	11	10	9	8	7	6	5	4	3	2	1	0
		<input type="checkbox"/>	<input type="checkbox"/>	<input type="checkbox"/>	<input type="checkbox"/>	<input type="checkbox"/>	<input type="checkbox"/>	<input type="checkbox"/>	<input type="checkbox"/>	<input type="checkbox"/>	<input type="checkbox"/>	<input type="checkbox"/>	<input type="checkbox"/>	<input type="checkbox"/>	<input type="checkbox"/>	<input type="checkbox"/>	<input type="checkbox"/>
Initial value	:	1	1	1	1	1	1	1	1	1	1	1	1	1	1	1	1
Read/Write	:	R/W	R/W	R/W	R/W	R/W	R/W	R/W	R/W	R/W	R/W	R/W	R/W	R/W	R/W	R/W	R/W

TCR5—Timer Control Register 5

H'FEA0

TPU5

Bit	7	6	5	4	3	2	1	0
	—	CCLR1	CCLR0	CKEG1	CKEG0	TPSC2	TPSC1	TPSC0
Initial value	0	0	0	0	0	0	0	0
Read/Write	—	R/W	R/W	R/W	R/W	R/W	R/W	R/W

Time Prescaler

0	0	0	Internal clock: counts on $\phi/1$
		1	Internal clock: counts on $\phi/4$
	1	0	Internal clock: counts on $\phi/16$
		1	Internal clock: counts on $\phi/64$
1	0	0	External clock: counts on TCLKA pin input
		1	External clock: counts on TCLKC pin input
	1	0	Internal clock: counts on $\phi/256$
		1	External clock: counts on TCLKD pin input

Note: This setting is ignored when channel 5 is in phase counting mode.

Clock Edge

0	0	Count at rising edge
	1	Count at falling edge
1	—	Count at both edges

Note: This setting is ignored when channel 5 is in phase counting mode. The internal clock edge selection is valid when the input clock is $\phi/4$ or slower. This setting is ignored if $\phi/1$ or overflow/underflow on another channel is selected as the input clock.

Counter Clear

0	0	TCNT clearing disabled
	1	TCNT cleared by TGRA compare match/input capture
1	0	TCNT cleared by TGRB compare match/input capture
	1	TCNT cleared by counter clearing for another channel performing synchronous clearing/synchronous operation*

Note: * Synchronous operation setting is performed by setting the SYNC bit in TSYR to 1.

TMDR5—Timer Mode Register 5**H'FEA1****TPU5**

Bit	:	7	6	5	4	3	2	1	0
		—	—	—	—	MD3	MD2	MD1	MD0
Initial value	:	1	1	0	0	0	0	0	0
Read/Write	:	—	—	—	—	R/W	R/W	R/W	R/W

Mode

0	0	0	0	Normal operation	
			1	Reserved	
		1	0	0	PWM mode 1
				1	PWM mode 2
	1	0	0	0	Phase counting mode 1
				1	Phase counting mode 2
		1	0	0	Phase counting mode 3
				1	Phase counting mode 4
1				—	

: Don't care

Note: MD3 is a reserved bit. In a write, it should always be written with 0.

TIOR5—Timer I/O Control Register 5

H'FEA2

TPU5

Bit :	7	6	5	4	3	2	1	0
	IOB3	IOB2	IOB1	IOB0	IOA3	IOA2	IOA1	IOA0
Initial value :	0	0	0	0	0	0	0	0
Read/Write :	R/W	R/W	R/W	R/W	R/W	R/W	R/W	R/W

TGR5A I/O Control

0	0	0	0	TGR5A is output compare register	Output disabled		
					1	Initial output is 0 output	0 output at compare match
					0	1 output at compare match	
		1	1		Toggle output at compare match		
			0		0	Output disabled	
					1	Initial output is 1 output	0 output at compare match
	0	1 output at compare match					
	1	0	0	TGR5A is input capture register	Input capture at rising edge		
					1	Input capture at falling edge	
					1	Input capture at both edges	
		1	0		0	Input capture at rising edge	
						1	Input capture at falling edge
1						Input capture at both edges	

: Don't care

TGR5B I/O Control

0	0	0	TGR5B is output compare register	Output disabled		
				1	Initial output is 0 output	0 output at compare match
				0	1 output at compare match	
		1		1	Toggle output at compare match	
				0	0	Output disabled
					1	Initial output is 1 output
	0	1 output at compare match				
	1	0	0	TGR5B is input capture register	Input capture at rising edge	
					1	Input capture at falling edge
					1	Input capture at both edges
		1	0		0	Input capture at rising edge
						1
1						Input capture at both edges

: Don't care

TIER5—Timer Interrupt Enable Register 5

H'FEA4

TPU5

Bit	7	6	5	4	3	2	1	0
	TTGE	—	TCIEU	TCIEV	—	—	TGIEB	TGIEA
Initial value :	0	1	0	0	0	0	0	0
Read/Write :	R/W	—	R/W	R/W	—	—	R/W	R/W

TGR Interrupt Enable A	
0	Interrupt request (TGIA) by TGFA bit disabled
1	Interrupt request (TGIA) by TGFA bit enabled

TGR Interrupt Enable B	
0	Interrupt request (TGIB) by TGFB bit disabled
1	Interrupt request (TGIB) by TGFB bit enabled

Overflow Interrupt Enable	
0	Interrupt request (TCIV) by TCFV disabled
1	Interrupt request (TCIV) by TCFV enabled

Underflow Interrupt Enable	
0	Interrupt request (TCIU) by TCFU disabled
1	Interrupt request (TCIU) by TCFU enabled

A/D Conversion Start Request Enable	
0	A/D conversion start request generation disabled
1	A/D conversion start request generation enabled

TSR5—Timer Status Register 5

H'FEA5

TPU5

Bit	7	6	5	4	3	2	1	0
	TCFD	—	TCFU	TCFV	—	—	TGFB	TGFA
Initial value	1	1	0	0	0	0	0	0
Read/Write	R	—	R/(W)*	R/(W)*	—	—	R/(W)*	R/(W)*

Input Capture/Output Compare Flag A	
0	[Clearing conditions] <ul style="list-style-type: none"> When DTC is activated by TGIA interrupt while DISEL bit of MRB in DTC is 0 When 0 is written to TGFA after reading TGFA = 1
1	[Setting conditions] <ul style="list-style-type: none"> When TCNT = TGRA while TGRA is functioning as output compare register When TCNT value is transferred to TGRA by input capture signal while TGRA is functioning as input capture register

Input Capture/Output Compare Flag B	
0	[Clearing conditions] <ul style="list-style-type: none"> When DTC is activated by TGIB interrupt while DISEL bit of MRB in DTC is 0 When 0 is written to TGFB after reading TGFB = 1
1	[Setting conditions] <ul style="list-style-type: none"> When TCNT = TGRB while TGRB is functioning as output compare register When TCNT value is transferred to TGRB by input capture signal while TGRB is functioning as input capture register

Overflow Flag	
0	[Clearing condition] When 0 is written to TCFV after reading TCFV = 1
1	[Setting condition] When the TCNT value overflows (changes from H'FFFF to H'0000)

Underflow Flag	
0	[Clearing condition] When 0 is written to TCFU after reading TCFU = 1
1	[Setting condition] When the TCNT value underflows (changes from H'0000 to H'FFFF)

Count Direction Flag	
0	TCNT counts down
1	TCNT counts up

Note: * Can only be written with 0 for flag clearing.

TCNT5—Timer Counter 5**H'FEA6****TPU5**

Bit	:	15	14	13	12	11	10	9	8	7	6	5	4	3	2	1	0
		<input type="checkbox"/>	<input type="checkbox"/>	<input type="checkbox"/>	<input type="checkbox"/>	<input type="checkbox"/>	<input type="checkbox"/>	<input type="checkbox"/>	<input type="checkbox"/>	<input type="checkbox"/>	<input type="checkbox"/>	<input type="checkbox"/>	<input type="checkbox"/>	<input type="checkbox"/>	<input type="checkbox"/>	<input type="checkbox"/>	<input type="checkbox"/>
Initial value	:	0	0	0	0	0	0	0	0	0	0	0	0	0	0	0	0
Read/Write	:	R/W	R/W	R/W	R/W	R/W	R/W	R/W	R/W	R/W	R/W	R/W	R/W	R/W	R/W	R/W	R/W

|
Up/down-counter*

Note: * This timer counter can be used as an up/down-counter only in phase counting mode or when performing overflow/underflow counting on another channel. In other cases it functions as an up-counter.

TGR5A—Timer General Register 5A**H'FEA8****TPU5****TGR5B—Timer General Register 5B****H'FEAA****TPU5**

Bit	:	15	14	13	12	11	10	9	8	7	6	5	4	3	2	1	0
		<input type="checkbox"/>	<input type="checkbox"/>	<input type="checkbox"/>	<input type="checkbox"/>	<input type="checkbox"/>	<input type="checkbox"/>	<input type="checkbox"/>	<input type="checkbox"/>	<input type="checkbox"/>	<input type="checkbox"/>	<input type="checkbox"/>	<input type="checkbox"/>	<input type="checkbox"/>	<input type="checkbox"/>	<input type="checkbox"/>	<input type="checkbox"/>
Initial value	:	1	1	1	1	1	1	1	1	1	1	1	1	1	1	1	1
Read/Write	:	R/W	R/W	R/W	R/W	R/W	R/W	R/W	R/W	R/W	R/W	R/W	R/W	R/W	R/W	R/W	R/W

P1DDR—Port 1 Data Direction Register**H'FEB0****Port 1**

Bit	:	7	6	5	4	3	2	1	0
		<input type="checkbox"/>	<input type="checkbox"/>	<input type="checkbox"/>	<input type="checkbox"/>	<input type="checkbox"/>	<input type="checkbox"/>	<input type="checkbox"/>	<input type="checkbox"/>
Initial value	:	0	0	0	0	0	0	0	0
Read/Write	:	W	W	W	W	W	W	W	W

|
Specify input or output for individual port 1 pins

P2DDR—Port 2 Data Direction Register**H'FEB1****Port 2**

Bit	:	7	6	5	4	3	2	1	0
		P27DDR	P26DDR	P25DDR	P24DDR	P23DDR	P22DDR	P21DDR	P20DDR
Initial value	:	0	0	0	0	0	0	0	0
Read/Write	:	W	W	W	W	W	W	W	W

Specify input or output for individual port 2 pins

P3DDR—Port 3 Data Direction Register**H'FEB2****Port 3**

Bit	:	7	6	5	4	3	2	1	0
		—	—	P35DDR	P34DDR	P33DDR	P32DDR	P31DDR	P30DDR
Initial value	:	Undefined	Undefined	0	0	0	0	0	0
Read/Write	:	—	—	W	W	W	W	W	W

Specify input or output for individual port 3 pins

PADDR—Port A Data Direction Register**H'FEB9****Port A**

Bit	:	7	6	5	4	3	2	1	0
		—	—	—	—	PA3DDR	PA2DDR	PA1DDR	PA0DDR
Initial value	:	Undefined	Undefined	Undefined	Undefined	0	0	0	0
Read/Write	:	—	—	—	—	W	W	W	W

Specify input or output for individual port A pins

PBDDR—Port B Data Direction Register**H'FEBA****Port B**

Bit	:	7	6	5	4	3	2	1	0
		PB7DDR	PB6DDR	PB5DDR	PB4DDR	PB3DDR	PB2DDR	PB1DDR	PB0DDR
Initial value	:	0	0	0	0	0	0	0	0
Read/Write	:	W	W	W	W	W	W	W	W

Specify input or output for individual port B pins

PCDDR—Port C Data Direction Register**H'FEBB****Port C**

Bit	:	7	6	5	4	3	2	1	0
		PC7DDR	PC6DDR	PC5DDR	PC4DDR	PC3DDR	PC2DDR	PC1DDR	PC0DDR
Initial value	:	0	0	0	0	0	0	0	0
Read/Write	:	W	W	W	W	W	W	W	W

Specify input or output for individual port C pins

PDDDR—Port D Data Direction Register**H'FEBC****Port D**

Bit	:	7	6	5	4	3	2	1	0
		PD7DDR	PD6DDR	PD5DDR	PD4DDR	PD3DDR	PD2DDR	PD1DDR	PD0DDR
Initial value	:	0	0	0	0	0	0	0	0
Read/Write	:	W	W	W	W	W	W	W	W

Specify input or output for individual port D pins

PEDDR—Port E Data Direction Register**H'FEBD****Port E**

Bit	:	7	6	5	4	3	2	1	0
		PE7DDR	PE6DDR	PE5DDR	PE4DDR	PE3DDR	PE2DDR	PE1DDR	PE0DDR
Initial value	:	0	0	0	0	0	0	0	0
Read/Write	:	W	W	W	W	W	W	W	W

Specify input or output for individual port E pins

PFDDR—Port F Data Direction Register**H'FEBE****Port F**

Bit	:	7	6	5	4	3	2	1	0
		PF7DDR	PF6DDR	PF5DDR	PF4DDR	PF3DDR	PF2DDR	PF1DDR	PF0DDR
Modes 4 to 6*									
Initial value	:	1	0	0	0	0	0	0	0
Read/Write	:	W	W	W	W	W	W	W	W
Mode 7*									
Initial value	:	0	0	0	0	0	0	0	0
Read/Write	:	W	W	W	W	W	W	W	W

Specify input or output for individual port F pins

Note: * Modes 6 and 7 cannot be used in the ROMless versions.

PGDDR—Port G Data Direction Register**H'FEBF****Port G**

Bit	:	7	6	5	4	3	2	1	0
		—	—	—	PG4DDR	PG3DDR	PG2DDR	PG1DDR	PG0DDR

Modes 4 and 5

Initial value : Undefined Undefined Undefined 1 0 0 0 0

Read/Write : — — — W W W W W

Modes 6 and 7*

Initial value : Undefined Undefined Undefined 0 0 0 0 0

Read/Write : — — — W W W W W

Specify input or output for individual port G pins

Note: * Modes 6 and 7 cannot be used in the ROMless versions.

IPRA—Interrupt Priority Register A	H'FEC4	Interrupt Controller
IPRB—Interrupt Priority Register B	H'FEC5	Interrupt Controller
IPRC—Interrupt Priority Register C	H'FEC6	Interrupt Controller
IPRD—Interrupt Priority Register D	H'FEC7	Interrupt Controller
IPRE—Interrupt Priority Register E	H'FEC8	Interrupt Controller
IPRF—Interrupt Priority Register F	H'FEC9	Interrupt Controller
IPRG—Interrupt Priority Register G	H'FECA	Interrupt Controller
IPRH—Interrupt Priority Register H	H'FECB	Interrupt Controller
IPRI—Interrupt Priority Register I	H'FECC	Interrupt Controller
IPRJ—Interrupt Priority Register J	H'FECD	Interrupt Controller
IPRK—Interrupt Priority Register K	H'FECE	Interrupt Controller

Bit :	7	6	5	4	3	2	1	0
	—	IPR6	IPR5	IPR4	—	IPR2	IPR1	IPR0
Initial value :	0	1	1	1	0	1	1	1
Read/Write :	—	R/W	R/W	R/W	—	R/W	R/W	R/W

Set priority (levels 7 to 0) for interrupt sources

Correspondence between Interrupt Sources and IPR Settings

Register	Bits	
	6 to 4	2 to 0
IPRA	IRQ0	IRQ1
IPRB	IRQ2 IRQ3	IRQ4 IRQ5
IPRC	IRQ6 IRQ7	DTC
IPRD	WDT	—*
IPRE	—*	A/D converter
IPRF	TPU channel 0	TPU channel 1
IPRG	TPU channel 2	TPU channel 3
IPRH	TPU channel 4	TPU channel 5
IPRI	8-bit timer channel 0	8-bit timer channel 1
IPRJ	—*	SCI channel 0
IPRK	SCI channel 1	—*

Note: * Reserved bits.

ABWCR—Bus Width Control Register**H'FED0****Bus Controller**

Bit	:	7	6	5	4	3	2	1	0
		ABW7	ABW6	ABW5	ABW4	ABW3	ABW2	ABW1	ABW0

Modes 5 to 7*

Initial value :	1	1	1	1	1	1	1	1	1
R/W :	R/W	R/W	R/W	R/W	R/W	R/W	R/W	R/W	R/W

Mode 4

Initial value :	0	0	0	0	0	0	0	0	0
Read/Write :	R/W	R/W	R/W	R/W	R/W	R/W	R/W	R/W	R/W

Area 7 to 0 Bus Width Control

0	Area n is designated for 16-bit access
1	Area n is designated for 8-bit access

(n = 7 to 0)

Note: * Modes 6 and 7 cannot be used in the ROMless versions.

ASTCR—Access State Control Register**H'FED1****Bus Controller**

Bit	:	7	6	5	4	3	2	1	0
		AST7	AST6	AST5	AST4	AST3	AST2	AST1	AST0

Initial value :	1	1	1	1	1	1	1	1	1
Read/Write :	R/W	R/W	R/W	R/W	R/W	R/W	R/W	R/W	R/W

Area 7 to 0 Access State Control

0	Area n is designated for 2-state access Wait state insertion in area n external space is disabled
1	Area n is designated for 3-state access Wait state insertion in area n external space is enabled

(n = 7 to 0)

WCRH—Wait Control Register H

H'FED2

Bus Controller

Bit :	7	6	5	4	3	2	1	0
	W71	W70	W61	W60	W51	W50	W41	W40
Initial value :	1	1	1	1	1	1	1	1
Read/Write :	R/W	R/W	R/W	R/W	R/W	R/W	R/W	R/W

Area 4 Wait Control

0	0	Program wait not inserted
	1	1 program wait state inserted
1	0	2 program wait states inserted
	1	3 program wait states inserted

Area 5 Wait Control

0	0	Program wait not inserted
	1	1 program wait state inserted
1	0	2 program wait states inserted
	1	3 program wait states inserted

Area 6 Wait Control

0	0	Program wait not inserted
	1	1 program wait state inserted
1	0	2 program wait states inserted
	1	3 program wait states inserted

Area 7 Wait Control

0	0	Program wait not inserted
	1	1 program wait state inserted
1	0	2 program wait states inserted
	1	3 program wait states inserted

WCRL—Wait Control Register L**H'FED3****Bus Controller**

Bit	:	7	6	5	4	3	2	1	0
		W31	W30	W21	W20	W11	W10	W01	W00
Initial value	:	1	1	1	1	1	1	1	1
Read/Write	:	R/W	R/W	R/W	R/W	R/W	R/W	R/W	R/W

Area 0 Wait Control

0	0	Program wait not inserted
	1	1 program wait state inserted
1	0	2 program wait states inserted
	1	3 program wait states inserted

Area 1 Wait Control

0	0	Program wait not inserted
	1	1 program wait state inserted
1	0	2 program wait states inserted
	1	3 program wait states inserted

Area 2 Wait Control

0	0	Program wait not inserted
	1	1 program wait state inserted
1	0	2 program wait states inserted
	1	3 program wait states inserted

Area 3 Wait Control

0	0	Program wait not inserted
	1	1 program wait state inserted
1	0	2 program wait states inserted
	1	3 program wait states inserted

BCRH—Bus Control Register H

H'FED4

Bus Controller

Bit :	7	6	5	4	3	2	1	0
	ICIS1	ICIS0	BRSTRM	BRSTS1	BRSTS0	—	—	—
Initial value :	1	1	0	1	0	0	0	0
Read/Write :	R/W	R/W	R/W	R/W	R/W	R/W	R/W	R/W

Reserved
Only 0 should be written to these bits

Burst Cycle Select 0

0	Max. 4 words in burst access
1	Max. 8 words in burst access

Burst Cycle Select 1

0	Burst cycle comprises 1 state
1	Burst cycle comprises 2 states

Area 0 Burst ROM Enable

0	Basic bus interface
1	Burst ROM interface

Idle Cycle Insert 0

0	Idle cycle not inserted in case of successive external read and external write cycles
1	Idle cycle inserted in case of successive external read and external write cycles

Idle Cycle Insert 1

0	Idle cycle not inserted in case of successive external read cycles in different areas
1	Idle cycle inserted in case of successive external read cycles in different areas

BCRL—Bus Control Register L

H'FED5

Bus Controller

Bit	7	6	5	4	3	2	1	0
	BRLE	BREQOE	EAE	—	—	—	—	WAITE
Initial value	0	0	1	1	1	1	0	0
Read/Write	R/W	R/W	R/W	R/W	R/W	R/W	R/W	R/W

WAIT Pin Enable

0	Wait input by $\overline{\text{WAIT}}$ pin disabled
1	Wait input by $\overline{\text{WAIT}}$ pin enabled

Reserved
Only 0 should be written to this bit.

Reserved
Only 1 should be written to these bits.

External Address Enable

0	Addresses H'010000 to H'03FFFF ^{*2} : <ul style="list-style-type: none"> H8S/2319, H8S/2319C, H8S/2315, and H8S/2314: On-chip ROM H8S/2318: On-chip ROM H8S/2317, H8S/2317S: On-chip ROM at addresses H'010000 to H'01FFFF and reserved area^{*1} at addresses H'020000 to H'03FFFF H8S/2316S: Reserved area^{*1}
1	Addresses H'010000 to H'03FFFF ^{*2} : <ul style="list-style-type: none"> Expanded mode: External addresses Single-chip mode: Reserved area^{*1}

- Notes: 1. Do not access a reserved area.
 2. H'010000 to H'03FFFF in the H8S/2318, H'010000 to H'05FFFF in the H8S/2315 and H8S/2314, and H'010000 to H'07FFFF in the H8S/2319 and H8S/2319C.

BREQO Pin Enable

0	BREQO output disabled
1	BREQO output enabled

Bus Release Enable

0	External bus release disabled
1	External bus release enabled

RAMER—RAM Emulation Register**H'FEDB** **Flash Memory**
(Valid only in F-ZTAT versions*)

Bit	:	7	6	5	4	3	2	1	0
		—	—	—	—	RAMS	RAM2	RAM1	RAM0
Initial value	:	0	0	0	0	0	0	0	0
Read/Write	:	—	—	—	—	R/W	R/W	R/W	R/W

RAM Select, Flash Memory Area Select

RAMS	RAM2	RAM1	RAM0	RAM Area	Block Name	
0				H'FFDC00 to H'FFEBFF	RAM area, 4 kbytes	
1	0	0	0	H'000000 to H'000FFF	EB0 (4 kbytes)	
			1	H'001000 to H'001FFF	EB1 (4 kbytes)	
		1	0	H'002000 to H'002FFF	EB2 (4 kbytes)	
			1	H'003000 to H'003FFF	EB3 (4 kbytes)	
	1	0	0	0	H'004000 to H'004FFF	EB4 (4 kbytes)
				1	H'005000 to H'005FFF	EB5 (4 kbytes)
		1	0	0	H'006000 to H'006FFF	EB6 (4 kbytes)
				1	H'007000 to H'007FFF	EB7 (4 kbytes)

: Don't care

Note: * In the H8S/2314 F-ZTAT, this cannot be used and must not be accessed.

ISCRH—IRQ Sense Control Register H**H'FF2C****Interrupt Controller****ISCRL—IRQ Sense Control Register L****H'FF2D****Interrupt Controller**

ISCRH

Bit	:	15	14	13	12	11	10	9	8
		IRQ7SCB	IRQ7SCA	IRQ6SCB	IRQ6SCA	IRQ5SCB	IRQ5SCA	IRQ4SCB	IRQ4SCA
Initial value	:	0	0	0	0	0	0	0	0
Read/Write	:	R/W	R/W	R/W	R/W	R/W	R/W	R/W	R/W

|
IRQ7 to IRQ4 Sense Control A, B

ISCRL

Bit	:	7	6	5	4	3	2	1	0
		IRQ3SCB	IRQ3SCA	IRQ2SCB	IRQ2SCA	IRQ1SCB	IRQ1SCA	IRQ0SCB	IRQ0SCA
Initial value	:	0	0	0	0	0	0	0	0
Read/Write	:	R/W	R/W	R/W	R/W	R/W	R/W	R/W	R/W

|
IRQ3 to IRQ0 Sense Control A, B

IRQnSCB	IRQnSCA	Interrupt Request Generation
0	0	$\overline{\text{IRQn}}$ input low level
	1	Falling edge of $\overline{\text{IRQn}}$ input
1	0	Rising edge of $\overline{\text{IRQn}}$ input
	1	Both falling and rising edges of $\overline{\text{IRQn}}$ input

(n = 7 to 0)

IER—IRQ Enable Register**H'FF2E****Interrupt Controller**

Bit	:	7	6	5	4	3	2	1	0
		IRQ7E	IRQ6E	IRQ5E	IRQ4E	IRQ3E	IRQ2E	IRQ1E	IRQ0E
Initial value	:	0	0	0	0	0	0	0	0
Read/Write	:	R/W	R/W	R/W	R/W	R/W	R/W	R/W	R/W

|
IRQn Enable

0	IRQn interrupt disabled
1	IRQn interrupt enabled

(n = 7 to 0)

ISR—IRQ Status Register

H'FF2F

Interrupt Controller

Bit	:	7	6	5	4	3	2	1	0
		IRQ7F	IRQ6F	IRQ5F	IRQ4F	IRQ3F	IRQ2F	IRQ1F	IRQ0F
Initial value :		0	0	0	0	0	0	0	0
Read/Write :		R/(W)*	R/(W)*	R/(W)*	R/(W)*	R/(W)*	R/(W)*	R/(W)*	R/(W)*

Indicate the status of IRQ7 to IRQ0 interrupt requests

Bit n

IRQnF

Description

0	<p>[Clearing conditions] (Initial value)</p> <ul style="list-style-type: none"> When 0 is written to IRQnF after reading IRQnF = 1 When interrupt exception handling is executed while low-level detection is set (IRQnSCB = IRQnSCA = 0) and $\overline{\text{IRQn}}$ input is high When IRQn interrupt exception handling is executed while falling, rising, or both-edge detection is set (IRQnSCB = 1 or IRQnSCA = 1) When the DTC is activated by an IRQn interrupt and the DISEL bit in the DTC's MRB register is 0
1	<p>[Setting conditions]</p> <ul style="list-style-type: none"> When $\overline{\text{IRQn}}$ input goes low while low-level detection is set (IRQnSCB = IRQnSCA = 0) When a falling edge occurs in $\overline{\text{IRQn}}$ input while falling edge detection is set (IRQnSCB = 0, IRQnSCA = 1) When a rising edge occurs in $\overline{\text{IRQn}}$ input while rising edge detection is set (IRQnSCB = 1, IRQnSCA = 0) When a falling or rising edge occurs in $\overline{\text{IRQn}}$ input while both-edge detection is set (IRQnSCB = IRQnSCA = 1)

(n = 7 to 0)

Note: * Can only be written with 0 for flag clearing.

DTCERA to DTCERF—DTC Enable Registers**H'FF30 to H'FF34****DTC**

Bit	:	7	6	5	4	3	2	1	0
		DTCE7	DTCE6	DTCE5	DTCE4	DTCE3	DTCE2	DTCE1	DTCE0
Initial value :		0	0	0	0	0	0	0	0
Read/Write :		R/W	R/W	R/W	R/W	R/W	R/W	R/W	R/W

DTC Activation Enable

0	DTC activation by this interrupt is disabled [Clearing conditions] • When the DISEL bit is 1 and data transfer has ended • When the specified number of transfers have ended
1	DTC activation by this interrupt is enabled [Holding condition] When the DISEL bit is 0 and the specified number of transfers have not ended

Correspondence between Interrupt Sources and DTCER

Register	Bits							
	7	6	5	4	3	2	1	0
DTCERA	IRQ0	IRQ1	IRQ2	IRQ3	IRQ4	IRQ5	IRQ6	IRQ7
DTCERB	—	ADI	TGI0A	TGI0B	TGI0C	TGI0D	TGI1A	TGI1B
DTCERC	TGI2A	TGI2B	TGI3A	TGI3B	TGI3C	TGI3D	TGI4A	TGI4B
DTCERD	—	—	TGI5A	TGI5B	CMIA0	CMIB0	CMIA1	CMIB1
DTCERE	—	—	—	—	RXI0	TXI0	RXI1	TXI1

Note: For DTCE bit setting, read/write operations must be performed using bit-manipulation instructions such as BSET and BCLR. For the initial setting only, however, when multiple activation sources are set at one time, it is possible to disable interrupts and write after executing a dummy read on the relevant register.

DTVECR—DTC Vector Register**H'FF37****DTC**

Bit	:	7	6	5	4	3	2	1	0
		SWDTE	DTVEC6	DTVEC5	DTVEC4	DTVEC3	DTVEC2	DTVEC1	DTVEC0
Initial value :		0	0	0	0	0	0	0	0
Read/Write :		R/W	R/(W)*	R/(W)*	R/(W)*	R/(W)*	R/(W)*	R/(W)*	R/(W)*

Sets vector number for DTC software activation

DTC Software Activation Enable

0	<p>DTC software activation is disabled [Clearing conditions]</p> <ul style="list-style-type: none"> • When the DISEL bit is 0 and the specified number of transfers have not ended • When 0 is written to the SWDTE bit after a software activated data transfer end interrupt (SWDTEND) has been requested of the CPU
1	<p>DTC software activation is enabled [Holding conditions]</p> <ul style="list-style-type: none"> • When the DISEL bit is 1 and data transfer has ended • When the specified number of transfers have ended • During data transfer due to software activation

Note: * Bits DTVEC6 to DTVEC0 can be written to when SWDTE = 0.

SBYCR—Standby Control Register

H'FF38

Power-Down State

Bit	:	7	6	5	4	3	2	1	0
		SSBY	STS2	STS1	STS0	OPE	—	—	IRQ37S
Initial value :		0	0	0	0	1	0	0	0
Read/Write :		R/W	R/W	R/W	R/W	R/W	—	—	R/W

IRQ37 Software Standby Clear Select

0	IRQ3 to IRQ7 cannot be used as software standby mode clearing sources
1	IRQ3 to IRQ7 can be used as software standby mode clearing sources

Output Port Enable

0	In software standby mode, address bus and bus control signals are high-impedance
1	In software standby mode, address bus and bus control signals retain output state

Standby Timer Select

0	0	0	Standby time = 8192 states
		1	Standby time = 16384 states
	1	0	Standby time = 32768 states
		1	Standby time = 65536 states
1	0	0	Standby time = 131072 states
		1	Standby time = 262144 states
	1	0	Reserved
		1	Standby time = 16 states*

Note: * Cannot be used in the F-ZTAT versions.

Software Standby

0	Transition to sleep mode after execution of SLEEP instruction
1	Transition to software standby mode after execution of SLEEP instruction

SYSCR—System Control Register

H'FF39

MCU

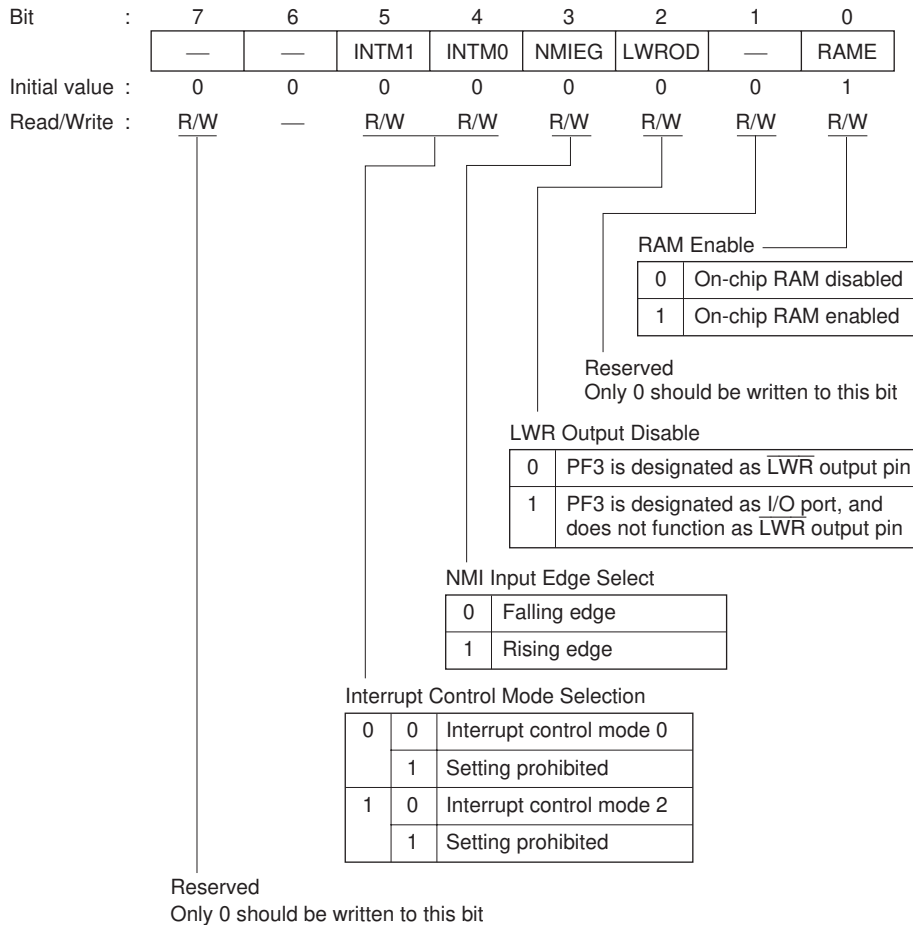

SCKCR—System Clock Control Register

H'FF3A

Clock Pulse Generator

Bit	:	7	6	5	4	3	2	1	0
		PSTOP	—	DIV	—	—	SCK2	SCK1	SCK0
Initial value	:	0	0	0	0	0	0	0	0
Read/Write	:	R/W	R/W	R/W	—	—	R/W	R/W	R/W

Division Ratio Select

Reserved
Only 0 should be written to this bit

System Clock Select

			DIV = 0	DIV = 1
0	0	0	Bus master is in high-speed mode	Bus master is in high-speed mode
		1	Medium-speed clock is $\phi/2$	Clock supplied to entire chip is $\phi/2$
	1	0	Medium-speed clock is $\phi/4$	Clock supplied to entire chip is $\phi/4$
		1	Medium-speed clock is $\phi/8$	Clock supplied to entire chip is $\phi/8$
1	0	0	Medium-speed clock is $\phi/16$	—
		1	Medium-speed clock is $\phi/32$	—
	1	—	—	—

ϕ Clock Output Control

PSTOP	Normal Operation	Sleep Mode	Software Standby Mode	Hardware Standby Mode
0	ϕ output	ϕ output	Fixed high	High impedance
1	Fixed high	Fixed high	Fixed high	High impedance

MDCR—Mode Control Register**H'FF3B****MCU**

Bit	:	7	6	5	4	3	2	1	0
		—	—	—	—	—	MDS2	MDS1	MDS0
Initial value	:	1	0	0	0	0	—*	—*	—*
Read/Write	:	—	—	—	—	—	R	R	R

|
Current mode pin operating mode

Note: * Determined by pins MD2 to MD0

MSTPCRH—Module Stop Control Register H**H'FF3C****Power-Down State****MSTPCRL—Module Stop Control Register L****H'FF3D****Power-Down State**

		MSTPCRH							MSTPCRL								
Bit	:	15	14	13	12	11	10	9	8	7	6	5	4	3	2	1	0
Initial value	:	0	0	1	1	1	1	1	1	1	1	1	1	1	1	1	1
Read/Write	:	R/W	R/W	R/W	R/W	R/W	R/W	R/W	R/W	R/W	R/W	R/W	R/W	R/W	R/W	R/W	R/W

Specifies module stop mode

0	Module stop mode cleared
1	Module stop mode set

MSTP Bits and On-Chip Supporting Modules

Register	Bits	Module
MSTPCRH	MSTP15	—
	MSTP14	DTC
	MSTP13	TPU
	MSTP12	8-bit timer
	MSTP11	—
	MSTP10	D/A
	MSTP9	A/D
	MSTP8	—
MSTPCRL	MSTP7	—
	MSTP6	SCI1
	MSTP5	SCI0
	MSTP4	—
	MSTP3	—
	MSTP2	—
	MSTP1	—
	MSTP0	—

SYSCR2—System Control Register 2**H'FF42****Flash Memory****(Valid only in F-ZTAT versions)**

Bit	:	7	6	5	4	3	2	1	0
		—	—	—	—	FLSHE	—	—	—
Initial value	:	0	0	0	0	0	0	0	0
Read/Write	:	—	—	—	—	R/W	—	—	— (R/W)

In the H8S/2319 and H8S/2319C, this bit is reserved and should be written with 0.

Flash Memory Control Register Enable

0	H8S/2319 F-ZTAT, H8S/2318 F-ZTAT, H8S/2317 F-ZTAT, H8S/2315 F-ZTAT, and H8S/2314 F-ZTAT <ul style="list-style-type: none"> Flash control registers are not selected for addresses H'FFFFC8 to H'FFFCB H8S/2319C F-ZTAT <ul style="list-style-type: none"> Flash control registers are not selected for addresses H'FFFFC4 to H'FFFCF
1	H8S/2319 F-ZTAT, H8S/2318 F-ZTAT, H8S/2317 F-ZTAT, H8S/2315 F-ZTAT, and H8S/2314 F-ZTAT <ul style="list-style-type: none"> Flash control registers are selected for addresses H'FFFFC8 to H'FFFCB H8S/2319C F-ZTAT <ul style="list-style-type: none"> Flash control registers are selected for addresses H'FFFFC4 to H'FFFCF

Reserved Register**H'FF44**

Bit	:	7	6	5	4	3	2	1	0
		—	—	—	—	—	—	—	—
Initial value	:	0	0	0	0	0	0	0	0
Read/Write	:	—	—	R/W	—	—	—	—	—

Reserved
Only 0 should be written to these bits

PFCR1—Port Function Control Register 1

H'FF45

Port

Bit	:	7	6	5	4	3	2	1	0
		CSS17	CSS36	PF1CS5S	PF0CS4S	A23E	A22E	A21E	A20E
Initial value	:	0	0	0	0	1	1	1	1
Read/Write	:	R/W	R/W	R/W	R/W	R/W	R/W	R/W	R/W

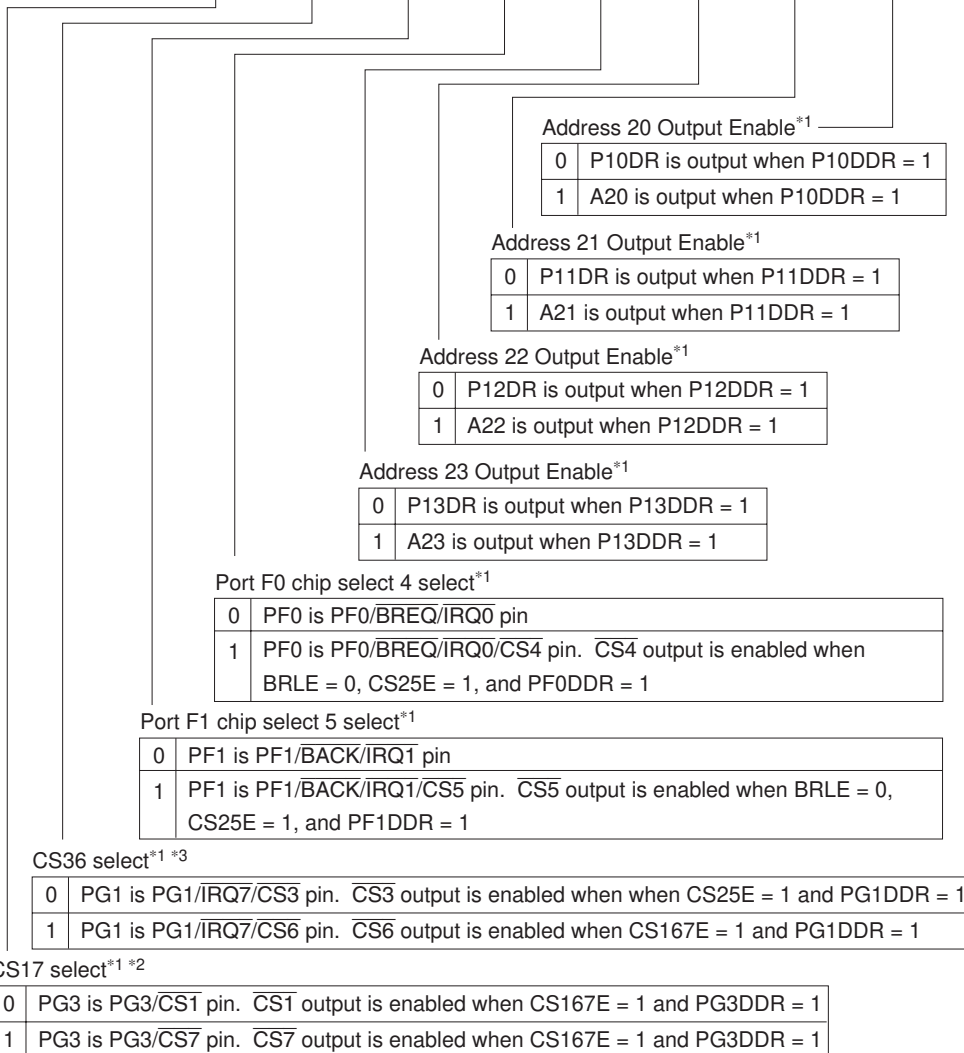

- Notes:
1. Valid in modes 4 to 6.
 2. Clear PG3DDR to 0 before changing the CSS17 bit setting.
 3. Clear PG1DDR to 0 before changing the CSS36 bit setting.

PORT1—Port 1 Register

H'FF50

Port 1

Bit	:	7	6	5	4	3	2	1	0
		P17	P16	P15	P14	P13	P12	P11	P10
Initial value :		—*	—*	—*	—*	—*	—*	—*	—*
Read/Write :		R	R	R	R	R	R	R	R

State of port 1 pins

Note: * Determined by the state of pins P17 to P10.

PORT2—Port 2 Register

H'FF51

Port 2

Bit	:	7	6	5	4	3	2	1	0
		P27	P26	P25	P24	P23	P22	P21	P20
Initial value :		—*	—*	—*	—*	—*	—*	—*	—*
Read/Write :		R	R	R	R	R	R	R	R

State of port 2 pins

Note: * Determined by the state of pins P27 to P20.

PORT3—Port 3 Register

H'FF52

Port 3

Bit	:	7	6	5	4	3	2	1	0
		—	—	P35	P34	P33	P32	P31	P30
Initial value :		Undefined	Undefined	—*	—*	—*	—*	—*	—*
Read/Write :		—	—	R	R	R	R	R	R

State of port 3 pins

Note: * Determined by the state of pins P35 to P30.

PORT4—Port 4 Register**H'FF53****Port 4**

Bit	:	7	6	5	4	3	2	1	0
		P47	P46	P45	P44	P43	P42	P41	P40
Initial value	:	—*	—*	—*	—*	—*	—*	—*	—*
Read/Write	:	R	R	R	R	R	R	R	R

|
State of port 4 pins

Note: * Determined by the state of pins P47 to P40.

PORTA—Port A Register**H'FF59****Port A**

Bit	:	7	6	5	4	3	2	1	0
		—	—	—	—	PA3	PA2	PA1	PA0
Initial value	:	Undefined	Undefined	Undefined	Undefined	—*	—*	—*	—*
Read/Write	:	—	—	—	—	R	R	R	R

|
State of port A pins

Note: * Determined by the state of pins PA3 to PA0.

PORTB—Port B Register**H'FF5A****Port B**

Bit	:	7	6	5	4	3	2	1	0
		PB7	PB6	PB5	PB4	PB3	PB2	PB1	PB0
Initial value	:	—*	—*	—*	—*	—*	—*	—*	—*
Read/Write	:	R	R	R	R	R	R	R	R

|
State of port B pins

Note: * Determined by the state of pins PB7 to PB0.

PORTC—Port C Register**H'FF5B****Port C**

Bit	:	7	6	5	4	3	2	1	0
		PC7	PC6	PC5	PC4	PC3	PC2	PC1	PC0
Initial value	:	—*	—*	—*	—*	—*	—*	—*	—*
Read/Write	:	R	R	R	R	R	R	R	R

|
State of port C pins

Note: * Determined by the state of pins PC7 to PC0.

PORTD—Port D Register**H'FF5C****Port D**

Bit	:	7	6	5	4	3	2	1	0
		PD7	PD6	PD5	PD4	PD3	PD2	PD1	PD0
Initial value	:	—*	—*	—*	—*	—*	—*	—*	—*
Read/Write	:	R	R	R	R	R	R	R	R

|
State of port D pins

Note: * Determined by the state of pins PD7 to PD0.

PORTE—Port E Register**H'FF5D****Port E**

Bit	:	7	6	5	4	3	2	1	0
		PE7	PE6	PE5	PE4	PE3	PE2	PE1	PE0
Initial value	:	—*	—*	—*	—*	—*	—*	—*	—*
Read/Write	:	R	R	R	R	R	R	R	R

|
State of port E pins

Note: * Determined by the state of pins PE7 to PE0.

PORTF—Port F Register**H'FF5E****Port F**

Bit	:	7	6	5	4	3	2	1	0
		PF7	PF6	PF5	PF4	PF3	PF2	PF1	PF0
Initial value	:	—*	—*	—*	—*	—*	—*	—*	—*
Read/Write	:	R	R	R	R	R	R	R	R

|
State of port F pins

Note: * Determined by the state of pins PF7 to PF0.

PORTG—Port G Register**H'FF5F****Port G**

Bit	:	7	6	5	4	3	2	1	0
		—	—	—	PG4	PG3	PG2	PG1	PG0
Initial value	:	Undefined	Undefined	Undefined	—*	—*	—*	—*	—*
Read/Write	:	—	—	—	R	R	R	R	R

|
State of port G pins

Note: * Determined by the state of pins PG4 to PG0.

P1DR—Port 1 Data Register**H'FF60****Port 1**

Bit	:	7	6	5	4	3	2	1	0
		P17DR	P16DR	P15DR	P14DR	P13DR	P12DR	P11DR	P10DR
Initial value	:	0	0	0	0	0	0	0	0
Read/Write	:	R/W	R/W	R/W	R/W	R/W	R/W	R/W	R/W

|
Stores output data for port 1 pins (P17 to P10)

P2DR—Port 2 Data Register**H'FF61****Port 2**

Bit	:	7	6	5	4	3	2	1	0
		P27DR	P26DR	P25DR	P24DR	P23DR	P22DR	P21DR	P20DR
Initial value :		0	0	0	0	0	0	0	0
Read/Write :		R/W	R/W	R/W	R/W	R/W	R/W	R/W	R/W

Stores output data for port 2 pins (P27 to P20)

P3DR—Port 3 Data Register**H'FF62****Port 3**

Bit	:	7	6	5	4	3	2	1	0
		—	—	P35DR	P34DR	P33DR	P32DR	P31DR	P30DR
Initial value :		Undefined	Undefined	0	0	0	0	0	0
Read/Write :		—	—	R/W	R/W	R/W	R/W	R/W	R/W

Stores output data for port 3 pins (P35 to P30)

PADR—Port A Data Register**H'FF69****Port A**

Bit	:	7	6	5	4	3	2	1	0
		—	—	—	—	PA3DR	PA2DR	PA1DR	PA0DR
Initial value :		Undefined	Undefined	Undefined	Undefined	0	0	0	0
Read/Write :		—	—	—	—	R/W	R/W	R/W	R/W

Stores output data for port A pins (PA3 to PA0)

PBDR—Port B Data Register**H'FF6A****Port B**

Bit	:	7	6	5	4	3	2	1	0
		PB7DR	PB6DR	PB5DR	PB4DR	PB3DR	PB2DR	PB1DR	PB0DR
Initial value :		0	0	0	0	0	0	0	0
Read/Write :		R/W	R/W	R/W	R/W	R/W	R/W	R/W	R/W

Stores output data for port B pins (PB7 to PB0)

PCDR—Port C Data Register**H'FF6B****Port C**

Bit	:	7	6	5	4	3	2	1	0
		PC7DR	PC6DR	PC5DR	PC4DR	PC3DR	PC2DR	PC1DR	PC0DR
Initial value :		0	0	0	0	0	0	0	0
Read/Write :		R/W	R/W	R/W	R/W	R/W	R/W	R/W	R/W

Stores output data for port C pins (PC7 to PC0)

PDDR—Port D Data Register**H'FF6C****Port D**

Bit	:	7	6	5	4	3	2	1	0
		PD7DR	PD6DR	PD5DR	PD4DR	PD3DR	PD2DR	PD1DR	PD0DR
Initial value :		0	0	0	0	0	0	0	0
Read/Write :		R/W	R/W	R/W	R/W	R/W	R/W	R/W	R/W

Stores output data for port D pins (PD7 to PD0)

PEDR—Port E Data Register**H'FF6D****Port E**

Bit	:	7	6	5	4	3	2	1	0
		PE7DR	PE6DR	PE5DR	PE4DR	PE3DR	PE2DR	PE1DR	PE0DR
Initial value :		0	0	0	0	0	0	0	0
Read/Write :		R/W	R/W	R/W	R/W	R/W	R/W	R/W	R/W

Stores output data for port E pins (PE7 to PE0)

PFDR—Port F Data Register**H'FF6E****Port F**

Bit	:	7	6	5	4	3	2	1	0
		PF7DR	PF6DR	PF5DR	PF4DR	PF3DR	PF2DR	PF1DR	PF0DR
Initial value :		0	0	0	0	0	0	0	0
Read/Write :		R/W	R/W	R/W	R/W	R/W	R/W	R/W	R/W

Stores output data for port F pins (PF7 to PF0)

PGDR—Port G Data Register**H'FF6F****Port G**

Bit	:	7	6	5	4	3	2	1	0
		—	—	—	PG4DR	PG3DR	PG2DR	PG1DR	PG0DR
Initial value :		Undefined	Undefined	Undefined	0	0	0	0	0
Read/Write :		—	—	—	R/W	R/W	R/W	R/W	R/W

Stores output data for port G pins (PG4 to PG0)

PAPCR—Port A MOS Pull-Up Control Register**H'FF70****Port A**

Bit	:	7	6	5	4	3	2	1	0
		—	—	—	—	PA3PCR	PA2PCR	PA1PCR	PA0PCR
Initial value	:	Undefined	Undefined	Undefined	Undefined	0	0	0	0
Read/Write	:	—	—	—	—	R/W	R/W	R/W	R/W

Controls the MOS input pull-up function incorporated into port A on a bit-by-bit basis

PBPCR—Port B MOS Pull-Up Control Register**H'FF71****Port B**

Bit	:	7	6	5	4	3	2	1	0
		PB7PCR	PB6PCR	PB5PCR	PB4PCR	PB3PCR	PB2PCR	PB1PCR	PB0PCR
Initial value	:	0	0	0	0	0	0	0	0
Read/Write	:	R/W	R/W	R/W	R/W	R/W	R/W	R/W	R/W

Controls the MOS input pull-up function incorporated into port B on a bit-by-bit basis

PCPCR—Port C MOS Pull-Up Control Register**H'FF72****Port C**

Bit	:	7	6	5	4	3	2	1	0
		PC7PCR	PC6PCR	PC5PCR	PC4PCR	PC3PCR	PC2PCR	PC1PCR	PC0PCR
Initial value	:	0	0	0	0	0	0	0	0
Read/Write	:	R/W	R/W	R/W	R/W	R/W	R/W	R/W	R/W

Controls the MOS input pull-up function incorporated into port C on a bit-by-bit basis

PDPCR—Port D MOS Pull-Up Control Register**H'FF73****Port D**

Bit	:	7	6	5	4	3	2	1	0
		PD7PCR	PD6PCR	PD5PCR	PD4PCR	PD3PCR	PD2PCR	PD1PCR	PD0PCR
Initial value	:	0	0	0	0	0	0	0	0
Read/Write	:	R/W	R/W	R/W	R/W	R/W	R/W	R/W	R/W

Controls the MOS input pull-up function incorporated into port D on a bit-by-bit basis

PEPCR—Port E MOS Pull-Up Control Register**H'FF74****Port E**

Bit	:	7	6	5	4	3	2	1	0
		PE7PCR	PE6PCR	PE5PCR	PE4PCR	PE3PCR	PE2PCR	PE1PCR	PE0PCR
Initial value	:	0	0	0	0	0	0	0	0
Read/Write	:	R/W	R/W	R/W	R/W	R/W	R/W	R/W	R/W

Controls the MOS input pull-up function incorporated into port E on a bit-by-bit basis

P3ODR—Port 3 Open Drain Control Register**H'FF76****Port 3**

Bit	:	7	6	5	4	3	2	1	0
		—	—	P35ODR	P34ODR	P33ODR	P32ODR	P31ODR	P30ODR
Initial value	:	Undefined	Undefined	0	0	0	0	0	0
Read/Write	:	—	—	R/W	R/W	R/W	R/W	R/W	R/W

Controls the PMOS on/off status for each port 3 pin (P35 to P30)

PAODR—Port A Open Drain Control Register**H'FF77****Port A**

Bit	:	7	6	5	4	3	2	1	0
		—	—	—	—	PA3ODR	PA2ODR	PA1ODR	PA0ODR
Initial value	:	Undefined	Undefined	Undefined	Undefined	0	0	0	0
Read/Write	:	—	—	—	—	R/W	R/W	R/W	R/W

Controls the PMOS on/off status
for each port A pin (PA3 to PA0)

SMR0—Serial Mode Register 0

H'FF78

SCIO

Bit	7	6	5	4	3	2	1	0
	C/ \bar{A}	CHR	PE	O/ \bar{E}	STOP	MP	CKS1	CKS0
Initial value	0	0	0	0	0	0	0	0
Read/Write	R/W	R/W	R/W	R/W	R/W	R/W	R/W	R/W

Clock Select

0	0	ϕ clock
	1	$\phi/4$ clock
1	0	$\phi/16$ clock
	1	$\phi/64$ clock

Multiprocessor Mode

0	Multiprocessor function disabled
1	Multiprocessor format selected

Stop Bit Length

0	1 stop bit
1	2 stop bits

Parity Mode

0	Even parity ^{*1}
1	Odd parity ^{*2}

- Notes: 1. When even parity is selected, the parity bit added to transmit data makes an even number of 1s in the transmitted character and parity bit combined. Receive data must have an even number of 1s in the received character and parity bit combined.
2. When odd parity is selected, the parity bit added to transmit data makes an odd number of 1s in the transmitted character and parity bit combined. Receive data must have an odd number of 1s in the received character and parity bit combined.

Parity Enable

0	Parity bit addition and checking disabled
1	Parity bit addition and checking enabled*

Note: * When the PE bit is set to 1, the parity (even or odd) specified by the O/ \bar{E} bit is added to transmit data before transmission. In reception, the parity bit is checked for the parity (even or odd) specified by the O/ \bar{E} bit.

Character Length

0	8-bit data
1	7-bit data*

Note: * When 7-bit data is selected, the MSB (bit 7) of TDR is not transmitted. With 7-bit data, it is not possible to select LSB-first or MSB-first transfer.

Asynchronous Mode/Synchronous Mode Select

0	Asynchronous mode
1	Synchronous mode

SMR0—Serial Mode Register 0

H'FF78

Smart Card Interface 0

Bit	7	6	5	4	3	2	1	0
	GM	BLK	PE	O/E	BCP1	BCP0	CKS1	CKS0
Initial value	0	0	0	0	0	0	0	0
Read/Write	R/W	R/W	R/W	R/W	R/W	R/W	R/W	R/W

Clock Select

0	0	ϕ clock
	1	$\phi/4$ clock
1	0	$\phi/16$ clock
	1	$\phi/64$ clock

Base Clock Pulse

BCP1	BCP0	Base Clock Pulse
0	0	32 clocks
	1	64 clocks
1	0	372 clocks
	1	256 clocks

Parity Mode

0	Even parity ^{*1}
1	Odd parity ^{*2}

- Notes: 1. When even parity is selected, the parity bit added to transmit data makes an even number of 1s in the transmitted character and parity bit combined. Receive data must have an even number of 1s in the received character and parity bit combined.
2. When odd parity is selected, the parity bit added to transmit data makes an odd number of 1s in the transmitted character and parity bit combined. Receive data must have an odd number of 1s in the received character and parity bit combined.

Parity Enable

(Set to 1 when using the smart card interface)

0	Setting prohibited
1	Parity bit addition and checking enabled

Block Transfer Mode Select

0	Normal smart card interface mode
1	Block transfer mode

GSM Mode

0	Normal smart card interface mode operation <ul style="list-style-type: none"> · TEND flag generated 12.5 etu (11.5 etu in block transfer mode) after beginning of start bit · Clock output on/off control only
1	GSM mode smart card interface mode operation <ul style="list-style-type: none"> · TEND flag generated 11.0 etu after beginning of start bit · Fixed high/low-level control possible (set in SCR) in addition to clock output on/off control

Note: etu (Elementary Time Unit): Time for transfer of 1 bit

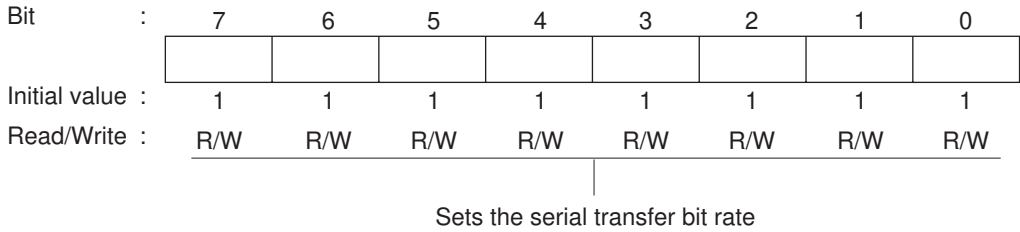
BRR0—Bit Rate Register 0**H'FF79 SCI0, Smart Card Interface 0**

Note: For details, see section 12.2.8, Bit Rate Register (BRR).

SCR0—Serial Control Register 0

H'FF7A

SCIO

Bit	7	6	5	4	3	2	1	0
	TIE	RIE	TE	RE	MPIE	TEIE	CKE1	CKE0
Initial value	0	0	0	0	0	0	0	0
Read/Write	R/W	R/W	R/W	R/W	R/W	R/W	R/W	R/W

Clock Enable

0	0	Asynchronous mode	Internal clock/SCK pin functions as I/O port
	1	Synchronous mode	Internal clock/SCK pin functions as serial clock output
1	0	Asynchronous mode	Internal clock/SCK pin functions as clock output ^{*1}
	1	Synchronous mode	Internal clock/SCK pin functions as serial clock output
1	0	Asynchronous mode	External clock/SCK pin functions as clock input ^{*2}
	1	Synchronous mode	External clock/SCK pin functions as serial clock input
1	0	Asynchronous mode	External clock/SCK pin functions as clock input ^{*2}
	1	Synchronous mode	External clock/SCK pin functions as serial clock input

Notes: 1. Outputs a clock of the same frequency as the bit rate.
2. Inputs a clock with a frequency 16 times the bit rate.

Transmit End Interrupt Enable

0	Transmit-end interrupt (TEI) request disabled*
1	Transmit-end interrupt (TEI) request enabled*

Note: * TEI clearing can be performed by reading 1 from the TDRE flag in SSR, then clearing it to 0 and clearing the TEND flag to 0, or by clearing the TEIE bit to 0.

Multiprocessor Interrupt Enable

0	Multiprocessor interrupts disabled [Clearing conditions] · When the MPIE bit is cleared to 0 · When data with MPB = 1 is received
1	Multiprocessor interrupts enabled* Receive-data-full interrupt (RXI) requests, receive-error interrupt (ERI) requests, and setting of the RDRF, FER, and ORER flags in SSR are disabled until data with the multiprocessor bit set to 1 is received

Note: * When receive data including MPB = 0 is received, receive data transfer from RSR to RDR, receive error detection, and setting of the RDRF, FER, and ORER flags in SSR, is not performed. When receive data including MPB = 1 is received, the MPB bit in SSR is set to 1, the MPIE bit is cleared to 0 automatically, and generation of RXI and ERI interrupts (when the TIE and RIE bits in SCR are set to 1) and FER and ORER flag setting is enabled.

Receive Enable

0	Reception disabled ^{*1}
1	Reception enabled ^{*2}

Notes: 1. Clearing the RE bit to 0 does not affect the RDRF, FER, PER, and ORER flags, which retain their states.
2. Serial reception is started in this state when a start bit is detected in asynchronous mode or serial clock input is detected in synchronous mode.
SMR setting must be performed to decide the receive format before setting the RE bit to 1.

Transmit Enable

0	Transmission disabled ^{*1}
1	Transmission enabled ^{*2}

Notes: 1. The TDRE flag in SSR is fixed at 1.
2. In this state, serial transmission is started when transmit data is written to TDR and the TDRE flag in SSR is cleared to 0.
SMR setting must be performed to decide the transmit format before setting the TE bit to 1.

Receive Interrupt Enable

0	Receive-data-full interrupt (RXI) request and receive-error interrupt (ERI) request disabled*
1	Receive-data-full interrupt (RXI) request and receive-error interrupt (ERI) request enabled

Note: * RXI and ERI interrupt requests can be cleared by reading 1 from the RDRF, FER, PER, or ORER flag, then clearing the flag to 0, or by clearing the RIE bit to 0.

Transmit Interrupt Enable

0	Transmit-data-empty interrupt (TXI) request disabled*
1	Transmit-data-empty interrupt (TXI) request enabled

Note: * TXI interrupt requests can be cleared by reading 1 from the TDRE flag, then clearing it to 0, or by clearing the TIE bit to 0.

SCR0—Serial Control Register 0

H'FF7A

Smart Card Interface 0

Bit	7	6	5	4	3	2	1	0
	TIE	RIE	TE	RE	MPIE	TEIE	CKE1	CKE0
Initial value	0	0	0	0	0	0	0	0
Read/Write	R/W	R/W	R/W	R/W	R/W	R/W	R/W	R/W

Clock Enable

SMCR	SMR	SCR setting		SCK pin function
SMIF	GM	CKE1	CKE0	
0				See SCI specification
1	0	0	0	Operates as port I/O pin
1	0	0	1	Clock output as SCK output pin
1	1	0	0	Fixed-low output as SCK output pin
1	1	0	1	Clock output as SCK output pin
1	1	1	0	Fixed-high output as SCK output pin
1	1	1	1	Clock output as SCK output pin

Transmit End Interrupt Enable

0	Transmit-end interrupt (TEI) request disabled*
1	Transmit-end interrupt (TEI) request enabled*

Note: * TEI clearing can be performed by reading 1 from the TDRE flag in SSR, then clearing it to 0 and clearing the TEND flag to 0, or by clearing the TEIE bit to 0.

Multiprocessor Interrupt Enable

0	Multiprocessor interrupts disabled [Clearing conditions] · When the MPIE bit is cleared to 0 · When data with MPB = 1 is received
1	Multiprocessor interrupts enabled* Receive-data-full interrupt (RXI) requests, receive-error interrupt (ERI) requests, and setting of the RDRF, FER, and ORER flags in SSR are disabled until data with the multiprocessor bit set to 1 is received

Note: * When receive data including MPB = 0 is received, receive data transfer from RSR to RDR, receive error detection, and setting of the RDRF, FER, and ORER flags in SSR, is not performed. When receive data including MPB = 1 is received, the MPB bit in SSR is set to 1, the MPIE bit is cleared to 0 automatically, and generation of RXI and ERI interrupts (when the TIE and RIE bits in SCR are set to 1) and FER and ORER flag setting is enabled.

Receive Enable

0	Reception disabled* ¹
1	Reception enabled* ²

Notes: 1. Clearing the RE bit to 0 does not affect the RDRF, FER, PER, and ORER flags, which retain their states.

2. Serial reception is started in this state when a start bit is detected in asynchronous mode or serial clock input is detected in synchronous mode.

SMR setting must be performed to decide the receive format before setting the RE bit to 1.

Transmit Enable

0	Transmission disabled* ¹
1	Transmission enabled* ²

Notes: 1. The TDRE flag in SSR is fixed at 1.

2. In this state, serial transmission is started when transmit data is written to TDR and the TDRE flag in SSR is cleared to 0.

SMR setting must be performed to decide the transmit format before setting the TE bit to 1.

Receive Interrupt Enable

0	Receive-data-full interrupt (RXI) request and receive-error interrupt (ERI) request disabled*
1	Receive-data-full interrupt (RXI) request and receive-error interrupt (ERI) request enabled

Note: * RXI and ERI interrupt requests can be cleared by reading 1 from the RDRF, FER, PER, or ORER flag, then clearing the flag to 0, or by clearing the RIE bit to 0.

Transmit Interrupt Enable

0	Transmit-data-empty interrupt (TXI) request disabled*
1	Transmit-data-empty interrupt (TXI) request enabled

Note: * TXI interrupt requests can be cleared by reading 1 from the TDRE flag, then clearing it to 0, or by clearing the TIE bit to 0.

TDR0—Transmit Data Register 0**H'FF7B****SCI0, Smart Card Interface 0**

Bit	:	7	6	5	4	3	2	1	0
Initial value :		1	1	1	1	1	1	1	1
Read/Write :		R/W	R/W	R/W	R/W	R/W	R/W	R/W	R/W

Stores data for serial transmission

SSR0—Serial Status Register 0

Bit	7	6	5	4	3	2	1	0
	TDRE	RDRF	ORER	FER	PER	TEND	MPB	MPBT
Initial value :	1	0	0	0	0	1	0	0
Read/Write :	R/(W)*	R/(W)*	R/(W)*	R/(W)*	R/(W)*	R	R	R/W

Multiprocessor Bit Transfer	
0	Data with a 0 multiprocessor bit is transmitted
1	Data with a 1 multiprocessor bit is transmitted

Multiprocessor Bit	
0	[Clearing condition] When data with a 0 multiprocessor bit is received*
1	[Setting condition] When data with a 1 multiprocessor bit is received

Note: * Retains its previous state when the RE bit in SCR is cleared to 0 with a multiprocessor format.

Transmit End	
0	[Clearing conditions] · When 0 is written to TDRE after reading TDRE = 1 · When the DTC is activated by a TXI interrupt and writes data to TDR
1	[Setting conditions] · When the TE bit in SCR is 0 · When TDRE = 1 at transmission of the last bit of a 1-byte serial transmit character

Parity Error	
0	[Clearing condition] When 0 is written to PER after reading PER = 1*1
1	[Setting condition] When, in reception, the number of 1 bits in the receive data plus the parity bit does not match the parity setting (even or odd) specified by the O/E bit in SMR*2

Notes: 1. The PER flag is not affected and retains its previous state when the RE bit in SCR is cleared to 0.
2. If a parity error occurs, the receive data is transferred to RDR but the RDRF flag is not set. Serial reception cannot be continued while the PER flag is set to 1. In synchronous mode, serial transmission is also disabled.

Framing Error	
0	[Clearing condition] When 0 is written to FER after reading FER = 1*1
1	[Setting condition] When the SCI checks the stop bit at the end of the receive data when reception ends, and the stop bit is 0*2

Notes: 1. The FER flag is not affected and retains its previous state when the RE bit in SCR is cleared to 0.
2. In 2-stop-bit mode, only the first stop bit is checked for a value of 1; the second stop bit is not checked. If a framing error occurs, the receive data is transferred to RDR but the RDRF flag is not set. Serial reception cannot be continued while the FER flag is set to 1. In synchronous mode, serial transmission is also disabled.

Overrun Error	
0	[Clearing condition] When 0 is written to ORER after reading ORER = 1*1
1	[Setting condition] When the next serial reception is completed while RDRF = 1*2

Notes: 1. The ORER flag is not affected and retains its previous state when the RE bit in SCR is cleared to 0.
2. The receive data prior to the overrun error is retained in RDR, and data received subsequently is lost. Serial reception cannot be continued while the ORER flag is set to 1. In synchronous mode, serial transmission is also disabled.

Receive Data Register Full*	
0	[Clearing conditions] · When 0 is written to RDRF after reading RDRF = 1 · When the DTC is activated by an RXI interrupt and reads data from RDR
1	[Setting condition] When serial reception ends normally and receive data is transferred from RSR to RDR

Note: * RDR and the RDRF flag are not affected and retain their previous values when an error is detected during reception or when the RE bit in SCR is cleared to 0. If reception of the next data is completed while the RDRF flag is still set to 1, an overrun error will occur and the receive data will be lost.

Transmit Data Register Empty	
0	[Clearing conditions] · When 0 is written to TDRE after reading TDRE = 1 · When the DTC is activated by a TXI interrupt and writes data to TDR
1	[Setting conditions] · When the TE bit in SCR is 0 · When data is transferred from TDR to TSR and data can be written to TDR

Note: * Can only be written with 0 for flag clearing.

SSR0—Serial Status Register 0

H'FF7C

Smart Card Interface 0

Bit	7	6	5	4	3	2	1	0
	TDRE	RDRF	ORER	ERS	PER	TEND	MPB	MPBT
Initial value :	1	0	0	0	0	1	0	0
Read/Write :	R/(W)*	R/(W)*	R/(W)*	R/(W)*	R/(W)*	R	R	R/W

Multiprocessor Bit Transfer	
0	Data with a 0 multiprocessor bit is transmitted
1	Data with a 1 multiprocessor bit is transmitted

Multiprocessor Bit	
0	[Clearing condition] When data with a 0 multiprocessor bit is received*
1	[Setting condition] When data with a 1 multiprocessor bit is received

Note: * Retains its previous state when the RE bit in SCR is cleared to 0 with a multiprocessor format.

Transmit End	
0	Transmission in progress [Clearing conditions] - When 0 is written to TDRE after reading TDRE = 1 - When the DTC is activated by a TXI interrupt and writes data to TDR
1	Transmission has ended [Setting conditions] - On reset, or in standby mode or module stop mode - When the TE bit in SCR is 0 and the ERS bit is 0 - When TDRE = 1 and ERS = 0 (normal transmission) 2.5 etu after transmission of a 1-byte serial character when GM = 0 and BLK = 0 - When TDRE = 1 and ERS = 0 (normal transmission) 1.5 etu after transmission of a 1-byte serial character when GM = 0 and BLK = 1 - When TDRE = 1 and ERS = 0 (normal transmission) 1.0 etu after transmission of a 1-byte serial character when GM = 1 and BLK = 0 - When TDRE = 1 and ERS = 0 (normal transmission) 1.0 etu after transmission of a 1-byte serial character when GM = 1 and BLK = 1

Note: etu (Elementary Time Unit): Time for transfer of 1 bit

Parity Error

0	[Clearing condition] When 0 is written to PER after reading PER = 1 ¹
1	[Setting condition] When, in reception, the number of 1 bits in the receive data plus the parity bit does not match the parity setting (even or odd) specified by the O/E bit in SMR ²

Notes: 1. The PER flag is not affected and retains its previous state when the RE bit in SCR is cleared to 0.
2. If a parity error occurs, the receive data is transferred to RDR but the RDRF flag is not set. Serial reception cannot be continued while the PER flag is set to 1. In synchronous mode, serial transmission is also disabled.

Error Signal Status^{*}

0	Data has been received normally, and there is no error signal [Clearing conditions] - On reset, or in standby mode or module stop mode - When 0 is written to ERS after reading ERS = 1
1	Error signal indicating detection of parity error has been sent by receiving device [Setting condition] When the error signal is sampled at the low level

Note: * Clearing the TE bit in SCR to 0 does not affect the ERS flag, which retains its prior state.

Overrun Error

0	[Clearing condition] When 0 is written to ORER after reading ORER = 1 ¹
1	[Setting condition] When the next serial reception is completed while RDRF = 1 ²

Notes: 1. The ORER flag is not affected and retains its previous state when the RE bit in SCR is cleared to 0.
2. The receive data prior to the overrun error is retained in RDR, and data received subsequently is lost. Serial reception cannot be continued while the ORER flag is set to 1. In synchronous mode, serial transmission is also disabled.

Receive Data Register Full^{*}

0	[Clearing conditions] - When 0 is written to RDRF after reading RDRF = 1 - When the DTC is activated by an RXI interrupt and reads data from RDR
1	[Setting condition] When serial reception ends normally and receive data is transferred from RSR to RDR

Note: * RDR and the RDRF flag are not affected and retain their previous values when an error is detected during reception or when the RE bit in SCR is cleared to 0.
If reception of the next data is completed while the RDRF flag is still set to 1, an overrun error will occur and the receive data will be lost.

Transmit Data Register Empty

0	[Clearing conditions] - When 0 is written to TDRE after reading TDRE = 1 - When the DTC is activated by a TXI interrupt and writes data to TDR
1	[Setting conditions] - When the TE bit in SCR is 0 - When data is transferred from TDR to TSR and data can be written to TDR

Note: * Can only be written with 0 for flag clearing.

RDR0—Receive Data Register 0

H'FF7D

SCI0, Smart Card Interface 0

Bit	:	7	6	5	4	3	2	1	0

Initial value : 0 0 0 0 0 0 0 0 0

Read/Write : R R R R R R R R

Stores received serial data

SCMR0—Smart Card Mode Register 0

H'FF7E

SCI0, Smart Card Interface 0

Bit	:	7	6	5	4	3	2	1	0
		—	—	—	—	SDIR	SINV	—	SMIF

Initial value : 1 1 1 1 0 0 1 0

Read/Write : — — — — R/W R/W — R/W

Smart Card Interface Mode Select

0	Smart card interface function is disabled
1	Smart card interface function is enabled

Smart Card Data Invert

0	TDR contents are transmitted as they are Receive data is stored in RDR as it is
1	TDR contents are inverted before being transmitted Receive data is stored in RDR in inverted form

Smart Card Data Direction

0	TDR contents are transmitted LSB-first Receive data is stored in RDR LSB-first
1	TDR contents are transmitted MSB-first Receive data is stored in RDR MSB-first

SMR1—Serial Mode Register 1

H'FF80

SCI1

Bit	7	6	5	4	3	2	1	0
	C/ \bar{A}	CHR	PE	O/ \bar{E}	STOP	MP	CKS1	CKS0
Initial value :	0	0	0	0	0	0	0	0
Read/Write :	R/W	R/W	R/W	R/W	R/W	R/W	R/W	R/W

Clock Select

0	0	ϕ clock
	1	$\phi/4$ clock
1	0	$\phi/16$ clock
	1	$\phi/64$ clock

Multiprocessor Mode

0	Multiprocessor function disabled
1	Multiprocessor format selected

Stop Bit Length

0	1 stop bit
1	2 stop bits

Parity Mode

0	Even parity ¹
1	Odd parity ²

- Notes: 1. When even parity is selected, the parity bit added to transmit data makes an even number of 1s in the transmitted character and parity bit combined. Receive data must have an even number of 1s in the received character and parity bit combined.
2. When odd parity is selected, the parity bit added to transmit data makes an odd number of 1s in the transmitted character and parity bit combined. Receive data must have an odd number of 1s in the received character and parity bit combined.

Parity Enable

0	Parity bit addition and checking disabled
1	Parity bit addition and checking enabled*

Note: * When the PE bit is set to 1, the parity (even or odd) specified by the O/ \bar{E} bit is added to transmit data before transmission. In reception, the parity bit is checked for the parity (even or odd) specified by the O/ \bar{E} bit.

Character Length

0	8-bit data
1	7-bit data*

Note: * When 7-bit data is selected, the MSB (bit 7) of TDR is not transmitted. With 7-bit data, it is not possible to select LSB-first or MSB-first transfer.

Asynchronous Mode/Synchronous Mode Select

0	Asynchronous mode
1	Synchronous mode

SMR1—Serial Mode Register 1

H'FF80

Smart Card Interface 1

Bit	7	6	5	4	3	2	1	0
	GM	BLK	PE	O/E	BCP1	BCP0	CKS1	CKS0
Initial value :	0	0	0	0	0	0	0	0
Read/Write :	R/W	R/W	R/W	R/W	R/W	R/W	R/W	R/W

Clock Select

0	0	ϕ clock
	1	$\phi/4$ clock
1	0	$\phi/16$ clock
	1	$\phi/64$ clock

Base Clock Pulse

BCP1	BCP0	Base Clock Pulse
0	0	32 clocks
	1	64 clocks
1	0	372 clocks
	1	256 clocks

Parity Mode

(Set to 1 when using the smart card interface)

0	Even parity ^{*1}
1	Odd parity ^{*2}

- Notes: 1. When even parity is selected, the parity bit added to transmit data makes an even number of 1s in the transmitted character and parity bit combined. Receive data must have an even number of 1s in the received character and parity bit combined.
2. When odd parity is selected, the parity bit added to transmit data makes an odd number of 1s in the transmitted character and parity bit combined. Receive data must have an odd number of 1s in the received character and parity bit combined.

Parity Enable

0	Setting prohibited
1	Parity bit addition and checking enabled*

Note: * When the PE bit is set to 1, the parity (even or odd) specified by the O/E bit is added to transmit data before transmission. In reception, the parity bit is checked for the parity (even or odd) specified by the O/E bit.

Block Transfer Mode Select

0	Normal smart card interface mode
1	Block transfer mode

GSM Mode

0	Normal smart card interface mode operation <ul style="list-style-type: none"> · TEND flag generated 12.5 etu (11.5 etu in block transfer mode) after beginning of start bit · Clock output on/off control only
1	GSM mode smart card interface mode operation <ul style="list-style-type: none"> · TEND flag generated 11.0 etu after beginning of start bit · Fixed high/low-level control possible (set in SCR) in addition to clock output on/off control

Note: etu (Elementary Time Unit): Time for transfer of 1 bit

BRR1—Bit Rate Register 1**H'FF81****SCI1, Smart Card Interface 1**

Bit	:	7	6	5	4	3	2	1	0
Initial value	:	1	1	1	1	1	1	1	1
Read/Write	:	R/W	R/W	R/W	R/W	R/W	R/W	R/W	R/W

Sets the serial transfer bit rate

Note: For details, see section 12.2.8, Bit Rate Register (BRR).

SCR1—Serial Control Register 1

H'FF82

SCI1

Bit	7	6	5	4	3	2	1	0
	TIE	RIE	TE	RE	MPIE	TEIE	CKE1	CKE0
Initial value	0	0	0	0	0	0	0	0
Read/Write	R/W	R/W	R/W	R/W	R/W	R/W	R/W	R/W

Clock Enable

0	0	Asynchronous mode	Internal clock/SCK pin functions as I/O port
	1	Synchronous mode	Internal clock/SCK pin functions as serial clock output
1	0	Asynchronous mode	Internal clock/SCK pin functions as clock output ^{*1}
	1	Synchronous mode	Internal clock/SCK pin functions as serial clock output
1	0	Asynchronous mode	External clock/SCK pin functions as clock input ^{*2}
	1	Synchronous mode	External clock/SCK pin functions as serial clock input
1	0	Asynchronous mode	External clock/SCK pin functions as clock input ^{*2}
	1	Synchronous mode	External clock/SCK pin functions as serial clock input

- Notes: 1. Outputs a clock of the same frequency as the bit rate.
2. Inputs a clock with a frequency 16 times the bit rate

Transmit End Interrupt Enable

0	Transmit-end interrupt (TEI) request disabled*
1	Transmit-end interrupt (TEI) request enabled*

Note: * TEI clearing can be performed by reading 1 from the TDRE flag in SSR, then clearing it to 0 and clearing the TEND flag to 0, or by clearing the TEIE bit to 0.

Multiprocessor Interrupt Enable

0	Multiprocessor interrupts disabled [Clearing conditions] · When the MPIE bit is cleared to 0 · When data with MPB = 1 is received
1	Multiprocessor interrupts enabled* Receive-data-full interrupt (RXI) requests, receive-error interrupt (ERI) requests, and setting of the RDRF, FER, and ORER flags in SSR are disabled until data with the multiprocessor bit set to 1 is received

Note: * When receive data including MPB = 0 is received, receive data transfer from RSR to RDR, receive error detection, and setting of the RDRF, FER, and ORER flags in SSR, is not performed. When receive data including MPB = 1 is received, the MPB bit in SSR is set to 1, the MPIE bit is cleared to 0 automatically, and generation of RXI and ERI interrupts (when the TIE and RIE bits in SCR are set to 1) and FER and ORER flag setting is enabled.

Receive Enable

0	Reception disabled ^{*1}
1	Reception enabled ^{*2}

- Notes: 1. Clearing the RE bit to 0 does not affect the RDRF, FER, PER, and ORER flags, which retain their states.
2. Serial reception is started in this state when a start bit is detected in asynchronous mode or serial clock input is detected in synchronous mode.
SMR setting must be performed to decide the receive format before setting the RE bit to 1.

Transmit Enable

0	Transmission disabled ^{*1}
1	Transmission enabled ^{*2}

- Notes: 1. The TDRE flag in SSR is fixed at 1.
2. In this state, serial transmission is started when transmit data is written to TDR and the TDRE flag in SSR is cleared to 0.
SMR setting must be performed to decide the transmit format before setting the TE bit to 1.

Receive Interrupt Enable

0	Receive-data-full interrupt (RXI) request and receive-error interrupt (ERI) request disabled*
1	Receive-data-full interrupt (RXI) request and receive-error interrupt (ERI) request enabled

Note: * RXI and ERI interrupt requests can be cleared by reading 1 from the RDRF, FER, PER, or ORER flag, then clearing the flag to 0, or by clearing the RIE bit to 0.

Transmit Interrupt Enable

0	Transmit-data-empty interrupt (TXI) request disabled*
1	Transmit-data-empty interrupt (TXI) request enabled

Note: * TXI interrupt requests can be cleared by reading 1 from the TDRE flag, then clearing it to 0, or by clearing the TIE bit to 0.

SCR1—Serial Control Register 1

H'FF82

Smart Card Interface 1

Bit	7	6	5	4	3	2	1	0
	TIE	RIE	TE	RE	MPIE	TEIE	CKE1	CKE0
Initial value	0	0	0	0	0	0	0	0
Read/Write	R/W	R/W	R/W	R/W	R/W	R/W	R/W	R/W

Clock Enable

SMCR	SMR	SCR setting		SCK pin function
		SMIF	GM	
0				See SCI specification
1	0	0	0	Operates as port I/O pin
1	0	0	1	Clock output as SCK output pin
1	1	0	0	Fixed-low output as SCK output pin
1	1	0	1	Clock output as SCK output pin
1	1	1	0	Fixed-high output as SCK output pin
1	1	1	1	Clock output as SCK output pin

Transmit End Interrupt Enable

0	Transmit-end interrupt (TEI) request disabled*
1	Transmit-end interrupt (TEI) request enabled*

Note: * TEI clearing can be performed by reading 1 from the TDRE flag in SSR, then clearing it to 0 and clearing the TEND flag to 0, or by clearing the TEIE bit to 0.

Multiprocessor Interrupt Enable

0	Multiprocessor interrupts disabled [Clearing conditions] - When the MPIE bit is cleared to 0 - When data with MPB = 1 is received
1	Multiprocessor interrupts enabled* Receive-data-full interrupt (RXI) requests, receive-error interrupt (ERI) requests, and setting of the RDRF, FER, and ORER flags in SSR are disabled until data with the multiprocessor bit set to 1 is received

Note: * When receive data including MPB = 0 is received, receive data transfer from RSR to RDR, receive error detection, and setting of the RDRF, FER, and ORER flags in SSR, is not performed. When receive data including MPB = 1 is received, the MPB bit in SSR is set to 1, the MPIE bit is cleared to 0 automatically, and generation of RXI and ERI interrupts (when the TIE and RIE bits in SCR are set to 1) and FER and ORER flag setting is enabled.

Receive Enable

0	Reception disabled* ¹
1	Reception enabled* ²

Notes: 1. Clearing the RE bit to 0 does not affect the RDRF, FER, PER, and ORER flags, which retain their states.
2. Serial reception is started in this state when a start bit is detected in asynchronous mode or serial clock input is detected in synchronous mode.
SMR setting must be performed to decide the receive format before setting the RE bit to 1.

Transmit Enable

0	Transmission disabled* ¹
1	Transmission enabled* ²

Notes: 1. The TDRE flag in SSR is fixed at 1.
2. In this state, serial transmission is started when transmit data is written to TDR and the TDRE flag in SSR is cleared to 0.
SMR setting must be performed to decide the transmit format before setting the TE bit to 1.

Receive Interrupt Enable

0	Receive-data-full interrupt (RXI) request and receive-error interrupt (ERI) request disabled
1	Receive-data-full interrupt (RXI) request and receive-error interrupt (ERI) request enabled

Note: * RXI and ERI interrupt requests can be cleared by reading 1 from the RDRF, FER, PER, or ORER flag, then clearing the flag to 0, or by clearing the RIE bit to 0.

Transmit Interrupt Enable

0	Transmit-data-empty interrupt (TXI) request disabled*
1	Transmit-data-empty interrupt (TXI) request enabled

Note: * TXI interrupt requests can be cleared by reading 1 from the TDRE flag, then clearing it to 0, or by clearing the TIE bit to 0.

TDR1—Transmit Data Register 1**H'FF83****SCI1, Smart Card Interface 1**

Bit	:	7	6	5	4	3	2	1	0
		<input type="checkbox"/>	<input type="checkbox"/>	<input type="checkbox"/>	<input type="checkbox"/>	<input type="checkbox"/>	<input type="checkbox"/>	<input type="checkbox"/>	<input type="checkbox"/>
Initial value	:	1	1	1	1	1	1	1	1
Read/Write	:	R/W	R/W	R/W	R/W	R/W	R/W	R/W	R/W

Stores data for serial transmission

SSR1—Serial Status Register 1

H'FF84

SCI1

Bit	7	6	5	4	3	2	1	0
	TDRE	RDRF	ORER	FER	PER	TEND	MPB	MPBT
Initial value	1	0	0	0	0	1	0	0
Read/Write	R/(W)*	R/(W)*	R/(W)*	R/(W)*	R/(W)*	R	R	R/W

Multiprocessor Bit Transfer	
0	Data with a 0 multiprocessor bit is transmitted
1	Data with a 1 multiprocessor bit is transmitted

Multiprocessor Bit	
0	[Clearing condition] When data with a 0 multiprocessor bit is received*
1	[Setting condition] When data with a 1 multiprocessor bit is received

Note: * Retains its previous state when the RE bit in SCR is cleared to 0 with a multiprocessor format.

Transmit End	
0	[Clearing conditions] • When 0 is written to TDRE after reading TDRE = 1 • When the DTC is activated by a TXI interrupt and writes data to TDR
1	[Setting conditions] • When the TE bit in SCR is 0 • When TDRE = 1 at transmission of the last bit of a 1-byte serial transmit character

Parity Error	
0	[Clearing condition] When 0 is written to PER after reading PER = 1*1
1	[Setting condition] When, in reception, the number of 1 bits in the receive data plus the parity bit does not match the parity setting (even or odd) specified by the O/E bit in SMR*2

Notes: 1. The PER flag is not affected and retains its previous state when the RE bit in SCR is cleared to 0.
2. If a parity error occurs, the receive data is transferred to RDR but the RDRF flag is not set. Serial reception cannot be continued while the PER flag is set to 1. In synchronous mode, serial transmission is also disabled.

Framing Error	
0	[Clearing condition] When 0 is written to FER after reading FER = 1*1
1	[Setting condition] When the SCI checks the stop bit at the end of the receive data when reception ends, and the stop bit is 0*2

Notes: 1. The FER flag is not affected and retains its previous state when the RE bit in SCR is cleared to 0.
2. In 2-stop-bit mode, only the first stop bit is checked for a value of 1; the second stop bit is not checked. If a framing error occurs, the receive data is transferred to RDR but the RDRF flag is not set. Serial reception cannot be continued while the FER flag is set to 1. In synchronous mode, serial transmission is also disabled.

Overrun Error	
0	[Clearing condition] When 0 is written to ORER after reading ORER = 1*1
1	[Setting condition] When the next serial reception is completed while RDRF = 1*2

Notes: 1. The ORER flag is not affected and retains its previous state when the RE bit in SCR is cleared to 0.
2. The receive data prior to the overrun error is retained in RDR, and data received subsequently is lost. Serial reception cannot be continued while the ORER flag is set to 1. In synchronous mode, serial transmission is also disabled.

Receive Data Register Full*	
0	[Clearing conditions] • When 0 is written to RDRF after reading RDRF = 1 • When the DTC is activated by an RXI interrupt and reads data from RDR
1	[Setting condition] When serial reception ends normally and receive data is transferred from RSR to RDR

Note: * RDR and the RDRF flag are not affected and retain their previous values when an error is detected during reception or when the RE bit in SCR is cleared to 0. If reception of the next data is completed while the RDRF flag is still set to 1, an overrun error will occur and the receive data will be lost.

Transmit Data Register Empty	
0	[Clearing conditions] • When 0 is written to TDRE after reading TDRE = 1 • When the DTC is activated by a TXI interrupt and writes data to TDR
1	[Setting conditions] • When the TE bit in SCR is 0 • When data is transferred from TDR to TSR and data can be written to TDR

Note: * Can only be written with 0 for flag clearing.

SSR1—Serial Status Register 1

H'FF84

Smart Card Interface 1

Bit	7	6	5	4	3	2	1	0
	TDRE	RDRF	ORER	ERS	PER	TEND	MPB	MPBT
Initial value	1	0	0	0	0	1	0	0
Read/Write	R/(W)*	R/(W)*	R/(W)*	R/(W)*	R/(W)*	R	R	RW

Multiprocessor Bit Transfer

0	Data with a 0 multiprocessor bit is transmitted
1	Data with a 1 multiprocessor bit is transmitted

Multiprocessor Bit

0	[Clearing condition] When data with a 0 multiprocessor bit is received*
1	[Setting condition] When data with a 1 multiprocessor bit is received

Note: * Retains its previous state when the RE bit in SCR is cleared to 0 with a multiprocessor format.

Transmit End

0	Transmission in progress [Clearing conditions] <ul style="list-style-type: none"> When 0 is written to TDRE after reading TDRE = 1 When the DTC is activated by a TXI interrupt and writes data to TDR
1	Transmission has ended [Setting conditions] <ul style="list-style-type: none"> On reset, or in standby mode or module stop mode When the TE bit in SCR is 0 and the ERS bit is 0 When TDRE = 1 and ERS = 0 (normal transmission) 2.5 etu after transmission of a 1-byte serial character when GM = 0 and BLK = 0 When TDRE = 1 and ERS = 0 (normal transmission) 1.5 etu after transmission of a 1-byte serial character when GM = 0 and BLK = 1 When TDRE = 1 and ERS = 0 (normal transmission) 1.0 etu after transmission of a 1-byte serial character when GM = 1 and BLK = 0 When TDRE = 1 and ERS = 0 (normal transmission) 1.0 etu after transmission of a 1-byte serial character when GM = 1 and BLK = 1

Note: etu (Elementary Time Unit): Time for transfer of 1 bit

Parity Error

0	[Clearing condition] When 0 is written to PER after reading PER = 1*1
1	[Setting condition] When, in reception, the number of 1 bits in the receive data plus the parity bit does not match the parity setting (even or odd) specified by the O/E bit in SMR*2

Notes: 1. The PER flag is not affected and retains its previous state when the RE bit in SCR is cleared to 0.
2. If a parity error occurs, the receive data is transferred to RDR but the RDRF flag is not set. Serial reception cannot be continued while the PER flag is set to 1. In synchronous mode, serial transmission is also disabled.

Error Signal Status*

0	Data has been received normally, and there is no error signal [Clearing conditions] <ul style="list-style-type: none"> On reset, or in standby mode or module stop mode When 0 is written to ERS after reading ERS = 1
1	Error signal indicating detection of parity error has been sent by receiving device [Setting condition] When the error signal is sampled at the low level

Note: * Clearing the TE bit in SCR to 0 does not affect the ERS flag, which retains its prior state.

Overrun Error

0	[Clearing condition] When 0 is written to ORER after reading ORER = 1*1
1	[Setting condition] When the next serial reception is completed while RDRF = 1*2

Notes: 1. The ORER flag is not affected and retains its previous values when an error is detected during reception or when the RE bit in SCR is cleared to 0.
2. The receive data prior to the overrun error is retained in RDR, and data received subsequently is lost. Serial reception cannot be continued while the ORER flag is set to 1. In synchronous mode, serial transmission is also disabled.

Receive Data Register Full*

0	[Clearing conditions] <ul style="list-style-type: none"> When 0 is written to RDRF after reading RDRF = 1 When the DTC is activated by an RXI interrupt and reads data from RDR
1	[Setting condition] When serial reception ends normally and receive data is transferred from RSR to RDR

Note: * RDR and the RDRF flag are not affected and retain their previous values when an error is detected during reception or when the RE bit in SCR is cleared to 0.
If reception of the next data is completed while the RDRF flag is still set to 1, an overrun error will occur and the receive data will be lost.

Transmit Data Register Empty

0	[Clearing conditions] <ul style="list-style-type: none"> When 0 is written to TDRE after reading TDRE = 1 When the DTC is activated by a TXI interrupt and writes data to TDR
1	[Setting conditions] <ul style="list-style-type: none"> When the TE bit in SCR is 0 When data is transferred from TDR to TSR and data can be written to TDR

Note: * Can only be written with 0 for flag clearing.

RDR1—Receive Data Register 1**H'FF85****SCI1, Smart Card Interface 1**

Bit	:	7	6	5	4	3	2	1	0

Initial value : 0 0 0 0 0 0 0 0 0

Read/Write : R R R R R R R R

Stores received serial data

SCMR1—Smart Card Mode Register 1**H'FF86****SCI1, Smart Card Interface 1**

Bit	:	7	6	5	4	3	2	1	0
		—	—	—	—	SDIR	SINV	—	SMIF

Initial value : 1 1 1 1 0 0 1 0

Read/Write : — — — — R/W R/W — R/W

Smart Card
Interface Mode Select

0	Smart card interface function is disabled
1	Smart card interface function is enabled

Smart Card Data Invert

0	TDR contents are transmitted as they are Receive data is stored in RDR as it is
1	TDR contents are inverted before being transmitted Receive data is stored in RDR in inverted form

Smart Card Data Direction

0	TDR contents are transmitted LSB-first Receive data is stored in RDR LSB-first
1	TDR contents are transmitted MSB-first Receive data is stored in RDR MSB-first

ADDRAH—A/D Data Register AH	H'FF90	A/D Converter
ADDRAL—A/D Data Register AL	H'FF91	A/D Converter
ADDRBH—A/D Data Register BH	H'FF92	A/D Converter
ADDRBL—A/D Data Register BL	H'FF93	A/D Converter
ADDRCH—A/D Data Register CH	H'FF94	A/D Converter
ADDRCL—A/D Data Register CL	H'FF95	A/D Converter
ADDRDH—A/D Data Register DH	H'FF96	A/D Converter
ADDRDL—A/D Data Register DL	H'FF97	A/D Converter

Bit	:	15	14	13	12	11	10	9	8	7	6	5	4	3	2	1	0
		AD9	AD8	AD7	AD6	AD5	AD4	AD3	AD2	AD1	AD0	—	—	—	—	—	—
Initial value	:	0	0	0	0	0	0	0	0	0	0	0	0	0	0	0	0
Read/Write	:	R	R	R	R	R	R	R	R	R	R	R	R	R	R	R	R

Stores the results of A/D conversion

Analog Input Channel		A/D Data Register
Group 0	Group 1	
AN0	AN4	ADDRA
AN1	AN5	ADDRB
AN2	AN6	ADDRC
AN3	AN7	ADDRD

ADCSR—A/D Control/Status Register

H'FF98

A/D Converter

Bit	:	7	6	5	4	3	2	1	0
		ADF	ADIE	ADST	SCAN	CKS	CH2	CH1	CH0
Initial value	:	0	0	0	0	0	0	0	0
Read/Write	:	R/(W)*	R/W	R/W	R/W	R/W	R/W	R/W	R/W

Channel Select

Note: These bits select the analog input channel(s).

Ensure that conversion is halted (ADST = 0) before making a channel setting.

Group Selection	Channel Selection			Description	
CH2	CH1	CH0	Single Mode (SCAN = 0)	Scan Mode (SCAN = 1)	
0	0	0	AN0	AN0	
		1	AN1	AN0, AN1	
	1	0	AN2	AN0 to AN2	
		1	AN3	AN0 to AN3	
1	0	0	AN4	AN4	
		1	AN5	AN4, AN5	
	1	0	AN6	AN4 to AN6	
		1	AN7	AN4 to AN7	

Clock Select

CKS is used in combination with CKS1, bit 3 in ADCR.

ADCR Bit 3	Bit 3	Description
CKS1	CKS	
0	0	Conversion time = 530 states (max.)
	1	Conversion time = 68 states (max.)
1	0	Conversion time = 266 states (max.)
	1	Conversion time = 134 states (max.)

Scan Mode

0	Single mode
1	Scan mode

A/D Start

0	A/D conversion stopped
1	<ul style="list-style-type: none"> Single mode: A/D conversion is started. Cleared to 0 automatically when conversion ends Scan mode: A/D conversion is started. Conversion continues sequentially on the selected channels until ADST is cleared to 0 by software, a reset, or transition to standby mode or module stop mode

A/D Interrupt Enable

0	A/D conversion end interrupt request disabled
1	A/D conversion end interrupt request enabled

A/D End Flag

0	[Clearing conditions] <ul style="list-style-type: none"> When 0 is written to the ADF flag after reading ADF = 1 When the DTC is activated by an ADI interrupt, and ADDR is read
1	[Setting conditions] <ul style="list-style-type: none"> Single mode: When A/D conversion ends Scan mode: When A/D conversion ends on all specified channels

Note: * Can only be written with 0 for flag clearing.

ADCR—A/D Control Register**H'FF99****A/D Converter**

Bit	:	7	6	5	4	3	2	1	0
		TRGS1	TRGS0	—	—	CKS1	—	—	—
Initial value	:	0	0	1	1	1	1	1	1
Read/Write	:	R/W	R/W	—	—	R/W	R/W	—	—

Reserved
Only 1 should be written to this bit.

Clock Select

CKS1 is used in combination with CKS, bit 3 in ADCSR.

Bit 3	ADCSR Bit 3	Description
CKS1	CKS	
0	0	Conversion time = 530 states (max.)
	1	Conversion time = 68 states (max.)
1	0	Conversion time = 266 states (max.)
	1	Conversion time = 134 states (max.)

Timer Trigger Select

TRGS1	TRGS0	Description
0	0	A/D conversion start by external trigger is disabled
	1	A/D conversion start by external trigger (TPU) is enabled
1	0	A/D conversion start by external trigger (8-bit timer) is enabled
	1	A/D conversion start by external trigger pin (ADTRG) is enabled

DADR0—D/A Data Register 0**H'FFA4****D/A Converter****DADR1—D/A Data Register 1****H'FFA5****D/A Converter**

Bit	:	7	6	5	4	3	2	1	0
Initial value	:	0	0	0	0	0	0	0	0
Read/Write	:	R/W	R/W	R/W	R/W	R/W	R/W	R/W	R/W

Stores data for D/A conversion

DACR01—D/A Control Register 01

H'FFA6

D/A Converter

Bit	:	7	6	5	4	3	2	1	0
		DAOE1	DAOE0	DAE	—	—	—	—	—
Initial value	:	0	0	0	1	1	1	1	1
Read/Write	:	R/W	R/W	R/W	—	—	—	—	—

D/A Output Enable 0

0	Analog output DA0 is disabled
1	Channel 0 D/A conversion is enabled Analog output DA0 is enabled

D/A Output Enable 1

0	Analog output DA1 is disabled
1	Channel 1 D/A conversion is enabled Analog output DA1 is enabled

D/A Conversion Control

DAOE1	DAOE0	DAE	Description
0	0		Channel 0 and 1 D/A conversion disabled
		0	Channel 0 D/A conversion enabled Channel 1 D/A conversion disabled
	1	Channel 0 and 1 D/A conversion enabled	
1	0	0	Channel 0 D/A conversion disabled Channel 1 D/A conversion enabled
		1	Channel 0 and 1 D/A conversion enabled
	1		Channel 0 and 1 D/A conversion enabled

: Don't care

PFCR2—Port Function Control Register 2

H'FFAC

Ports

Bit	:	7	6	5	4	3	2	1	0
		—	—	CS167E	CS25E	ASOD	—	—	—
Initial value	:	0	0	1	1	0	0	0	0
Read/Write	:	R/W	R/W	R/W	R/W	R/W	R	R	R

Reserved
Only 0 should be written to these bits

AS Output Disable*

0	PF6 is designated as \overline{AS} output pin
1	PF6 is designated as I/O port, and does not function as \overline{AS} output pin

Note: * This bit is valid in modes 4 to 6.

CS25 Enable*1 *2

0	$\overline{CS2}$, $\overline{CS3}$, $\overline{CS4}$, and $\overline{CS5}$ output disabled (can be used as I/O ports)
1	$\overline{CS2}$, $\overline{CS3}$, $\overline{CS4}$, and $\overline{CS5}$ output enabled

Notes: 1. This bit is valid in modes 4 to 6.
2. Clear the DDR bits to 0 before changing the CS25E setting.

CS167 Enable*1 *2

0	$\overline{CS1}$, $\overline{CS6}$, and $\overline{CS7}$ output disabled (can be used as I/O ports)
1	$\overline{CS1}$, $\overline{CS6}$, and $\overline{CS7}$ output enabled

Notes: 1. This bit is valid in modes 4 to 6.
2. Clear the DDR bits to 0 before changing the CS167E setting.

TCR0—Time Control Register 0**H'FFB0****8-Bit Timer Channel 0****TCR1—Time Control Register 1****H'FFB1****8-Bit Timer Channel 1**

Bit	:	7	6	5	4	3	2	1	0
		CMIEB	CMIEA	OVIE	CCLR1	CCLR0	CKS2	CKS1	CKS0
Initial value	:	0	0	0	0	0	0	0	0
Read/Write	:	R/W	R/W	R/W	R/W	R/W	R/W	R/W	R/W

Clock Select

0	0	0	Clock input disabled
		1	Internal clock: counted at falling edge of $\phi/8$
	1	0	Internal clock: counted at falling edge of $\phi/64$
		1	Internal clock: counted at falling edge of $\phi/8192$
1	0	0	For channel 0: Count at TCNT1 overflow signal* For channel 1: Count at TCNT0 compare match A*
		1	External clock: counted at rising edge
	1	0	External clock: counted at falling edge
		1	External clock: counted at both rising and falling edges

Note: * If the count input of channel 0 is the TCNT1 overflow signal and that of channel 1 is the TCNT0 compare match signal, no incrementing clock is generated. Do not use this setting.

Counter Clear

0	0	Clear is disabled
	1	Clear by compare match A
1	0	Clear by compare match B
	1	Clear by rising edge of external reset input

Timer Overflow Interrupt Enable

0	OVF interrupt requests (OVI) are disabled
1	OVF interrupt requests (OVI) are enabled

Compare Match Interrupt Enable A

0	CMFA interrupt requests (CMIA) are disabled
1	CMFA interrupt requests (CMIA) are enabled

Compare Match Interrupt Enable B

0	CMFB interrupt requests (CMIB) are disabled
1	CMFB interrupt requests (CMIB) are enabled

TCSR0—Timer Control/Status Register 0**H'FFB2****8-Bit Timer Channel 0****TCSR1—Timer Control/Status Register 1****H'FFB3****8-Bit Timer Channel 1**

TCSR0 Bit	:	7	6	5	4	3	2	1	0
		CMFB	CMFA	OVF	ADTE	OS3	OS2	OS1	OS0

Initial value : 0 0 0 0 0 0 0 0 0

Read/Write : R/(W)* R/(W)* R/(W)* R/W R/W R/W R/W R/W

TCSR1 Bit	:	7	6	5	4	3	2	1	0
		CMFB	CMFA	OVF	—	OS3	OS2	OS1	OS0

Initial value : 0 0 0 1 0 0 0 0 0

Read/Write : R/(W)* R/(W)* R/(W)* — R/W R/W R/W R/W

		Output Select	
0	0	No change when compare match A occurs	
	1	0 is output when compare match A occurs	
1	0	1 is output when compare match A occurs	
	1	Output is inverted when compare match A occurs (toggle output)	

		Output Select	
0	0	No change when compare match B occurs	
	1	0 is output when compare match B occurs	
1	0	1 is output when compare match B occurs	
	1	Output is inverted when compare match B occurs (toggle output)	

A/D Trigger Enable (TCSR0 only)

0	A/D converter start requests by compare match A are disabled
1	A/D converter start requests by compare match A are enabled

Timer Overflow Flag

0	[Clearing condition] When 0 is written to OVF after reading OVF = 1
1	[Setting condition] When TCNT overflows (changes from H'FF to H'00)

Compare Match Flag A

0	[Clearing conditions] <ul style="list-style-type: none"> When 0 is written to CMFA after reading CMFA = 1 When the DTC is activated by a CMIA interrupt, while the DISEL bit of MRB in DTC is 0
1	[Setting condition] When TCNT matches TCORA

Compare Match Flag B

0	[Clearing conditions] <ul style="list-style-type: none"> When 0 is written to CMFB after reading CMFB = 1 When the DTC is activated by a CMIB interrupt, while the DISEL bit of MRB in DTC is 0
1	[Setting condition] When TCNT matches TCORB

Note: * Only 0 can be written to bits 7 to 5, to clear these flags.

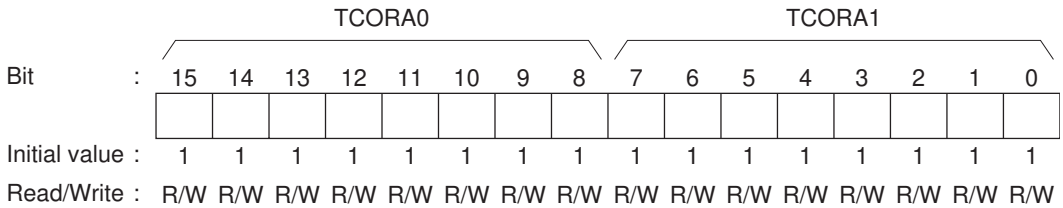
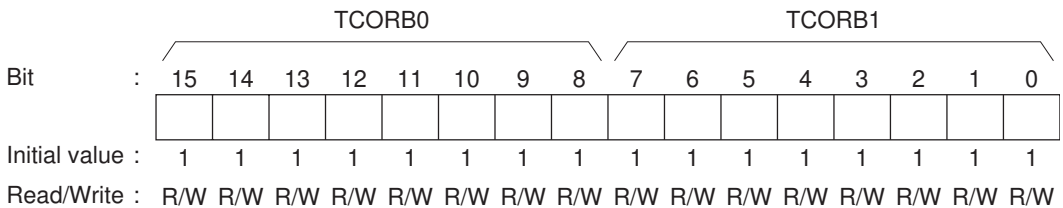
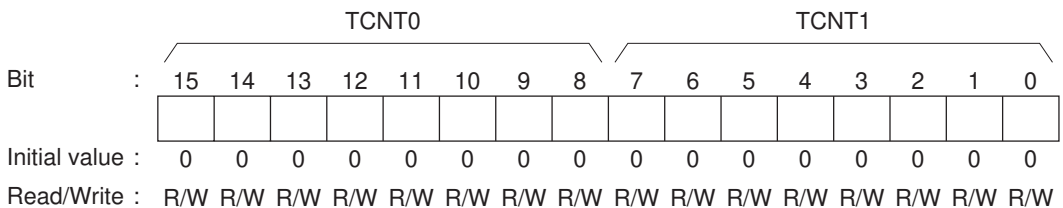
TCORA0—Time Constant Register A0**H'FFB4****8-Bit Timer Channel 0****TCORA1—Time Constant Register A1****H'FFB5****8-Bit Timer Channel 1****TCORB0—Time Constant Register B0****H'FFB6****8-Bit Timer Channel 0****TCORB1—Time Constant Register B1****H'FFB7****8-Bit Timer Channel 1****TCNT0—Timer Counter 0****H'FFB8****8-Bit Timer Channel 0****TCNT1—Timer Counter 1****H'FFB9****8-Bit Timer Channel 1**

TCSR—Timer Control/Status Register H'FFBC (W), H'FFBC (R)**WDT**

Bit	7	6	5	4	3	2	1	0
	OVF	WT/IT	TME	—	—	CKS2	CKS1	CKS0
Initial value	0	0	0	1	1	0	0	0
Read/Write*1:	R/(W)*2	R/W	R/W	—	—	R/W	R/W	R/W

Clock Select

CKS2	CKS1	CKS0	Clock	Overflow period* (when $\phi = 20$ MHz)
0	0	0	$\phi/2$	25.6 μ s
		1	$\phi/64$	819.2 μ s
	1	0	$\phi/128$	1.6 ms
		1	$\phi/512$	6.6 ms
1	0	0	$\phi/2048$	26.2 ms
		1	$\phi/8192$	104.9 ms
	1	0	$\phi/32768$	419.4 ms
		1	$\phi/131072$	1.68s

Note: * The overflow period is the time from when TCNT starts counting up from H'00 until overflow occurs.

Timer Enable

0	TCNT is initialized to H'00 and halted
1	TCNT counts

Timer Mode Select

0	Interval timer mode: Sends the CPU an interval timer interrupt request (WOVI) when TCNT overflows
1	Watchdog timer mode: Generates the $\overline{\text{WDTOVF}}$ signal*1 when TCNT overflows*2

- Notes: 1. The $\overline{\text{WDTOVF}}$ pin function cannot be used in the F-ZTAT versions.
 2. For details of the case where TCNT overflows in watchdog timer mode, see section 11.2.3, Reset Control/Status Register (RSTCSR).

Overflow Flag

0	[Clearing condition] When 0 is written to OVF after reading OVF = 1
1	[Setting condition] When TCNT overflows from H'FF to H'00 in interval timer mode

- Notes: 1. The method for writing to TCSR is different from that for general registers to prevent accidental overwriting. For details, see section 11.2.4, Notes on Register Access.
 2. Can only be written with 0 for flag clearing.

TCNT—Timer Counter**H'FFBC (W), H'FFBD (R)****WDT**

Bit	:	7	6	5	4	3	2	1	0
Initial value	:	0	0	0	0	0	0	0	0
Read/Write	:	R/W	R/W	R/W	R/W	R/W	R/W	R/W	R/W

Note: The method for writing to TCNT is different from that for general registers to prevent accidental overwriting. For details, see section 11.2.4, Notes on Register Access.

RSTCSR—Reset Control/Status Register**H'FFBE (W), H'FFBF (R)****WDT**

Bit	:	7	6	5	4	3	2	1	0
Initial value	:	0	0	0	1	1	1	1	1
Read/Write	:	R/(W)*	R/W	R/W	—	—	—	—	—

Reserved
This bit should be written with 0.

Reset Enable

0	Reset signal is not generated if TCNT overflows*
1	Reset signal is generated if TCNT overflows

Note: * The modules in the chip are not reset,
but TCNT and TCSR in WDT are reset.

Watchdog Timer Overflow Flag

0	[Clearing condition] Cleared by reading RSTCSR when WOVF = 1, then writing 0 to WOVF.
1	[Setting condition] When TCNT overflows (changes from H'FF to H'00) during watchdog timer operation

Notes: The method for writing to RSTCSR is different from that for general registers to prevent accidental overwriting. For details, see section 11.2.4, Notes on Register Access.

* Can only be written with 0 for flag clearing.

TSTR—Timer Start Register**H'FFC0****TPU**

Bit	:	7	6	5	4	3	2	1	0
		—	—	CST5	CST4	CST3	CST2	CST1	CST0
Initial value	:	0	0	0	0	0	0	0	0
Read/Write	:	—	—	R/W	R/W	R/W	R/W	R/W	R/W

Counter Start

0	TCNTn count operation is stopped
1	TCNTn performs count operation

(n = 5 to 0)

Note: If 0 is written to the CST bit during operation with the TIOC pin designated for output, the counter stops but the TIOC pin output compare output level is retained. If TIOR is written to when the CST bit is cleared to 0, the pin output level will be changed to the set initial output value.

TSYR—Timer Synchro Register**H'FFC1****TPU**

Bit	:	7	6	5	4	3	2	1	0
		—	—	SYNC5	SYNC4	SYNC3	SYNC2	SYNC1	SYNC0
Initial value	:	0	0	0	0	0	0	0	0
Read/Write	:	—	—	R/W	R/W	R/W	R/W	R/W	R/W

Timer Synchronization

0	TCNTn operates independently (TCNT presetting/clearing is unrelated to other channels)
1	TCNTn performs synchronous operation TCNT synchronous presetting/synchronous clearing is possible

(n = 5 to 0)

- Notes:
1. To set synchronous operation, the SYNC bits for at least two channels must be set to 1.
 2. To set synchronous clearing, in addition to the SYNC bit, the TCNT clearing source must also be set by means of bits CCLR2 to CCLR0 in TCR.

FLMCR1—Flash Memory Control Register 1 H'FFC8 Flash Memory

(Valid in the H8S/2318 F-ZTAT, H8S/2317 F-ZTAT, H8S/2315 F-ZTAT, and H8S/2314 F-ZTAT only)

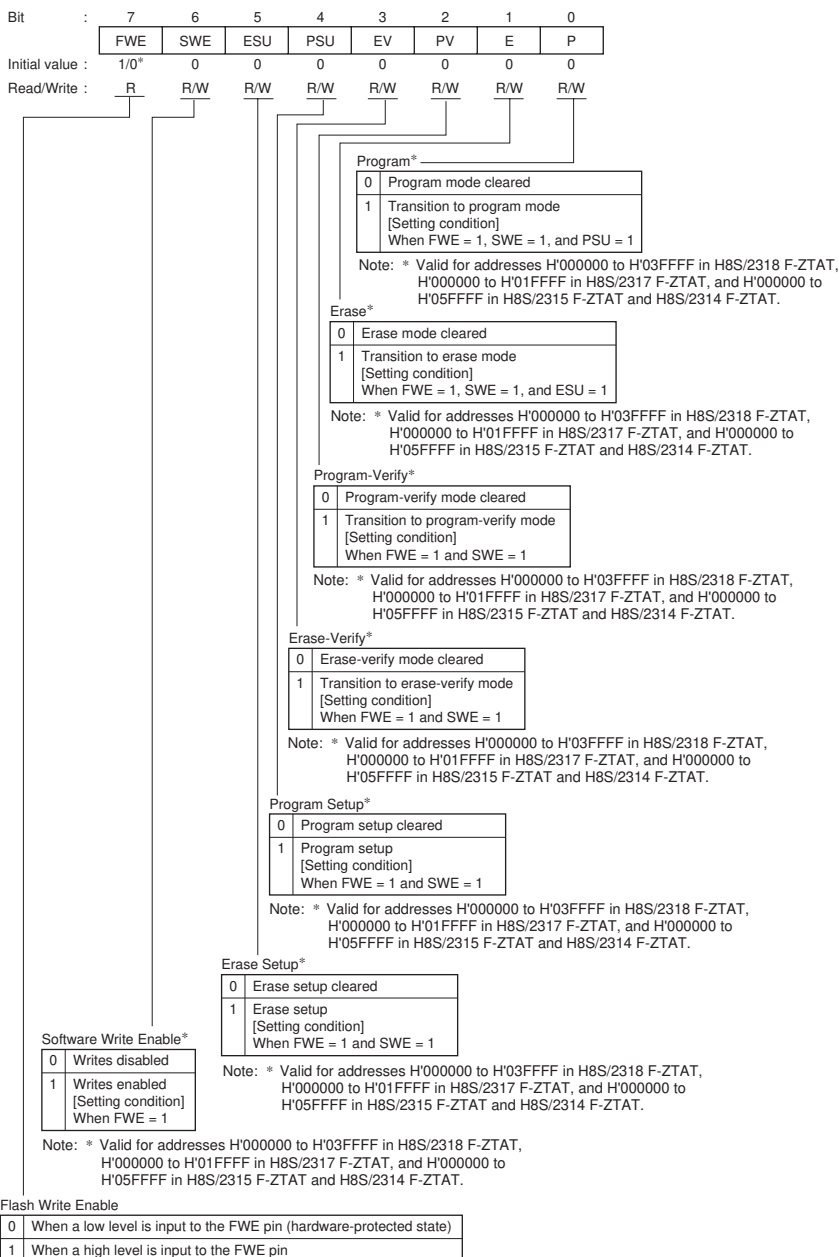

Note: * Determined by the state of the FWE pin.

FLMCR1—Flash Memory Control Register 1

H'FFC8

Flash Memory

(Valid in the H8S/2319 F-ZTAT only)

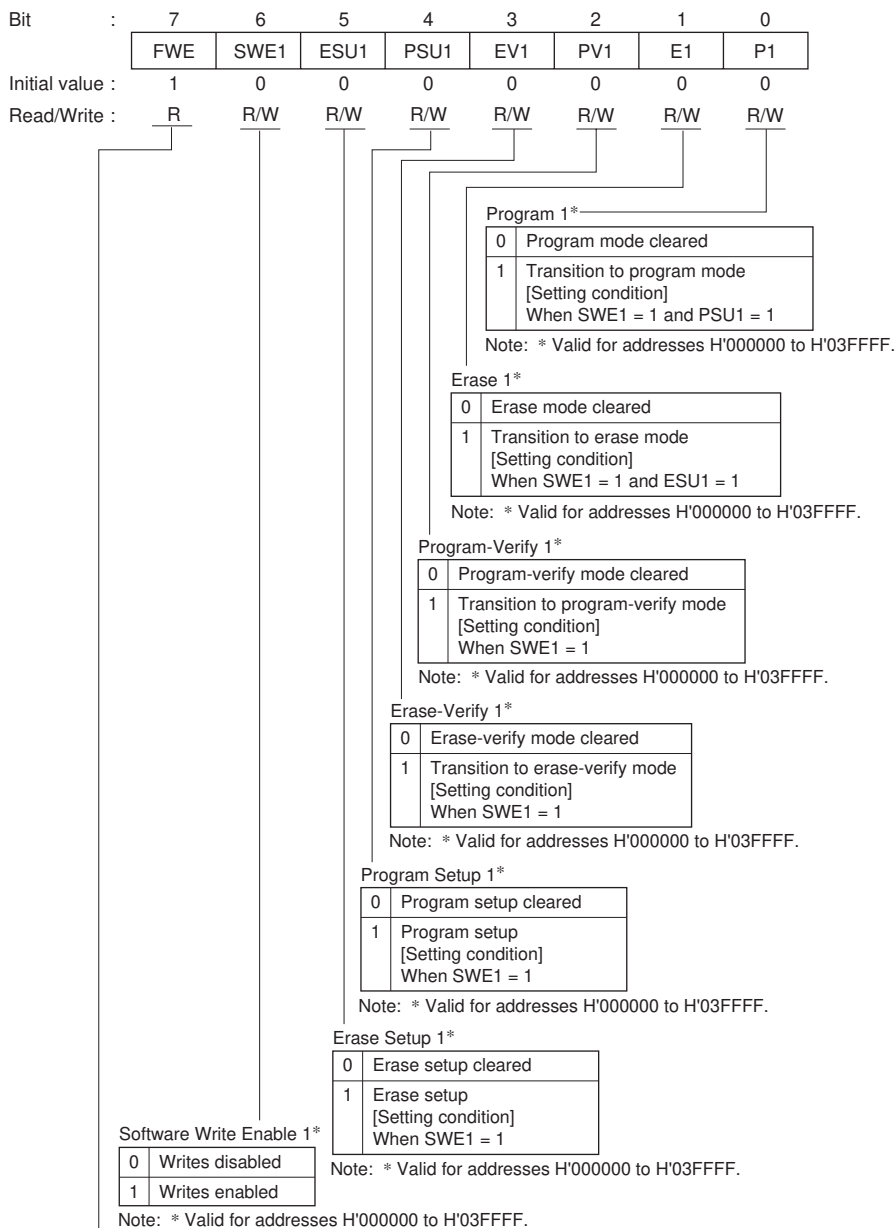

FLMCR2—Flash Memory Control Register 2 **H'FFC9** **Flash Memory**
(Valid in H8S/2318 F-ZTAT, H8S/2317 F-ZTAT, H8S/2315 F-ZTAT,
and H8S/2314 F-ZTAT only)

Bit	:	7	6	5	4	3	2	1	0
		FLER	—	—	—	—	—	—	—
Initial value	:	0	0	0	0	0	0	0	0
Read/Write	:	R	—	—	—	—	—	—	—

Flash Memory Error

0	Flash memory is operating normally Flash memory program/erase protection (error protection) is disabled [Clearing condition] Reset or hardware standby mode
1	An error has occurred during flash memory programming/erasing Flash memory program/erase protection (error protection) is enabled [Setting condition] See section 17.8.3, Error Protection

FLMCR2—Flash Memory Control Register 2

H'FFC9 Flash Memory
(Valid in the H8S/2319 F-ZTAT only)

Bit	7	6	5	4	3	2	1	0
	FLER	SWE2	ESU2	PSU2	EV2	PV2	E2	P2
Initial value :	0	0	0	0	0	0	0	0
Read/Write :	R	R/W	R/W	R/W	R/W	R/W	R/W	R/W

0	Program mode cleared
1	Transition to program mode [Setting condition] When SWE2 = 1 and PSU2 = 1

0	Erase mode cleared
1	Transition to erase mode [Setting condition] When SWE2 = 1 and ESU2 = 1

0	Program-verify mode cleared
1	Transition to program-verify mode [Setting condition] When SWE2 = 1

0	Erase-verify mode cleared
1	Transition to erase-verify mode [Setting condition] When SWE2 = 1

0	Program setup cleared
1	Program setup [Setting condition] When SWE2 = 1

0	Writes disabled
1	Writes enabled

0	Erase setup cleared
1	Erase setup [Setting condition] When SWE2 = 1

0	Flash memory is operating normally Flash memory program/erase protection (error protection) is disabled [Clearing condition] Reset or hardware standby mode
1	An error has occurred during flash memory programming/erasing Flash memory program/erase protection (error protection) is enabled [Setting condition] See section 17.17.3, Error Protection

Note: * Valid for addresses H'040000 to H'07FFFF.

EBR1—Erase Block Register 1**H'FFCA****Flash Memory****EBR2—Erase Block Register 2****H'FFCB****Flash Memory**

(Valid only in the H8S/2319 F-ZTAT, H8S/2318 F-ZTAT, H8S/2317 F-ZTAT,
H8S/2315 F-ZTAT, and H8S/2314 F-ZTAT)

Bit	:	7	6	5	4	3	2	1	0
EBR1		EB7	EB6	EB5	EB4	EB3	EB2	EB1	EB0
Initial value :		0	0	0	0	0	0	0	0
Read/Write :		R/W	R/W	R/W	R/W	R/W	R/W	R/W	R/W

Bit	:	7	6	5	4	3	2	1	0
EBR2		EB15* ³	EB14* ³	EB13* ²	EB12* ²	EB11* ¹	EB10* ¹	EB9	EB8
Initial value :		0	0	0	0	0	0	0	0
Read/Write :		R/W* ³	R/W* ³	R/W* ²	R/W* ²	R/W* ¹	R/W* ¹	R/W	R/W

- Notes: 1. Valid in the H8S/2319 F-ZTAT, H8S/2318 F-ZTAT, H8S/2315 F-ZTAT, and H8S/2314 F-ZTAT. In other products, write 0 to these bits.
2. Valid in the H8S/2319 F-ZTAT, H8S/2315 F-ZTAT, and H8S/2314 F-ZTAT. In other products, write 0 to these bits.
3. Valid in the H8S/2319 F-ZTAT. In other products, write 0 to these bits.

FCCS—Flash Code Control Status Register

**H'FFC4 FLASH
(Valid only in the H8S/2319C F-ZTAT)**

Bit	7	6	5	4	3	2	1	0
	—	—	—	FLER	—	—	—	SCO
Initial value :	1	0	0	0	0	0	0	0
Read/Write :	R	R	R	R	R	R	R	(R)/W

Source Program Copy Operation

0	Download of the on-chip programming/erasing program to the on-chip RAM is not executed [Clearing condition] When download is completed
1	Request that the on-chip programming/erasing program is downloaded to the on-chip RAM is occurred [Setting conditions] When all of the following conditions are satisfied and 1 is written to this bit <ul style="list-style-type: none"> • FKEY is written to H'A5 • During execution in the on-chip RAM • Not in RAM emulation mode (RAMS in RAMER = 0)

Reserved bits
These bits are always read as 0.
The write value should always be 0.

Flash Memory Error

0	Flash memory operates normally Programming/erasing protection for flash memory (error protection) is invalid. [Clearing condition] At a power-on reset or in hardware standby mode
1	Indicates an error occurs during programming/erasing flash memory. Programming/erasing protection for flash memory (error protection) is valid. [Setting condition] See section 17.25.3, Error Protection

Reserved bits
These bits are always read as 0.
The write value should always be 0.

Reserved bit
This bit is always read as 1.
The write value should always be 1.

FPCS—Flash Program Code Select Register**H'FFC5** **FLASH**
(Valid only in the H8S/2319C F-ZTAT)

Bit	:	7	6	5	4	3	2	1	0
		FVCHGE	—	—	—	—	—	—	—
Initial value	:	0	0	0	0	0	0	0	0
Read/Write	:	R/W	R/W	R/W	R/W	R/W	R/W	R/W	R/W

Reserved bits
These bits are always read as 0.
The write value should always be 0.

Vector Switch Function Valid

0	Function for modifying the space which reads the vector table data is invalid
1	Function for modifying the space which reads the vector table data is valid

FECS—Flash Erase Code Select Register**H'FFC6** **FLASH**
(Valid only in the H8S/2319C F-ZTAT)

Bit	:	7	6	5	4	3	2	1	0
		—	—	—	—	—	—	—	EPVB
Initial value	:	0	0	0	0	0	0	0	0
Read/Write	:	R	R	R	R	R	R	R	R/W

Erase Pulse Verify Block

0	On-chip erasing program is not selected [Clear condition] When transfer is completed
1	On-chip erasing program is selected

Reserved bits
These bits are always read as 0.
The write value should always be 0.

FKEY—Flash Key Code Register**H'FFC8** **FLASH**
(Valid only in the H8S/2319C F-ZTAT)

Bit	7	6	5	4	3	2	1	0
	K7	K6	K5	K4	K3	K2	K1	K0
Initial value	0	0	0	0	0	0	0	0
Read/Write	R/W	R/W	R/W	R/W	R/W	R/W	R/W	R/W

Key Code

H'A5	Writing to the SCO bit is enabled (The SCO bit cannot be set by the value other than H'A5.)
H'5A	Programming/erasing is enabled (The value other than H'5A is in software protection state.)
H'00	Initial value

FMATS—Flash MAT Select Register**H'FFC9** **FLASH**
(Valid only in the H8S/2319C F-ZTAT)

Bit	7	6	5	4	3	2	1	0	
	MS7	MS6	MS5	MS4	MS3	MS2	MS1	MS0	
Initial value	0	0	0	0	0	0	0	0	(When not in user boot mode)
Initial value	1	0	1	0	1	0	1	0	(When in user boot mode)
Read/Write	R/W	R/W	R/W	R/W	R/W	R/W	R/W	R/W	

MAT Select

H'AA	The user boot MAT is selected (in user-MAT selection state when the value of these bits are other than H'AA) Initial value when these bits are initiated in user boot mode
H'00	Initial value when these bits are initiated in a mode except for user boot mode (in user-MAT selection state)

[Programmable condition] These bits are in the execution state in the on-chip RAM.

FTDAR—Flash Transfer Destination Address Register H'FFCA FLASH

(Valid only in the H8S/2319C F-ZTAT)

Bit	:	7	6	5	4	3	2	1	0
		TDER	TDA6	TDA5	TDA4	TDA3	TDA2	TDA1	TDA0
Initial value	:	0	0	0	0	0	0	0	0
Read/Write	:	R/W	R/W	R/W	R/W	R/W	R/W	R/W	R/W

Transfer Destination Address

TDA6 to TDA0	Description
H'00	Download start address is set to H'FFBC00
H'01	Download start address is set to H'FFCC00
H'02	Download start address is set to H'FFDC00
H'03	Download start address is set to H'FFEC00
H'04 to H'7F	Setting prohibited. If this value is set, the TDER bit (bit 7) is set to 1 to abort the download processing

Transfer Destination Address Setting Error

0	Setting of TDA6 to TDA0 is normal
1	Setting of TDER and TDA4 to TDA0 is H'04 to H'FF and download has been aborted

TCR0—Timer Control Register 0

H'FFD0 **TPU0**
(Valid only in the H8S/2319C F-ZTAT)

Bit	7	6	5	4	3	2	1	0
	CCLR2	CCLR1	CCLR0	CKEG1	CKEG0	TPSC2	TPSC1	TPSC0
Initial value :	0	0	0	0	0	0	0	0
Read/Write :	R/W	R/W	R/W	R/W	R/W	R/W	R/W	R/W

Time Prescaler

0	0	0	Internal clock: counts on $\phi/1$
		1	Internal clock: counts on $\phi/4$
1	0	0	Internal clock: counts on $\phi/16$
		1	Internal clock: counts on $\phi/64$
1	0	0	External clock: counts on TCLKA pin input
		1	External clock: counts on TCLKB pin input
	1	0	External clock: counts on TCLKC pin input
		1	External clock: counts on TCLKD pin input

Clock Edge

0	0	Count at rising edge
	1	Count at falling edge
1	—	Count at both edges

Note: The internal clock edge selection is valid when the input clock is $\phi/4$ or slower. This setting is ignored if $\phi/1$ or overflow/underflow on another channel is selected as the input clock.

Counter Clear

0	0	0	TCNT clearing disabled
		1	TCNT cleared by TGRA compare match/input capture
	1	0	TCNT cleared by TGRB compare match/input capture
		1	TCNT cleared by counter clearing for another channel performing synchronous clearing/synchronous operation*1
1	0	0	TCNT clearing disabled
		1	TCNT cleared by TGRC compare match/input capture*2
	1	0	TCNT cleared by TGRD compare match/input capture*2
		1	TCNT cleared by counter clearing for another channel performing synchronous clearing/synchronous operation*1

- Notes: 1. Synchronous operation setting is performed by setting the SYNC bit in TSYR to 1.
2. When TGRC or TGRD is used as a buffer register, TCNT is not cleared because the buffer register setting has priority, and compare match/input capture does not occur.

TMDR0—Timer Mode Register 0**H'FFD1****TPU0**

Bit	:	7	6	5	4	3	2	1	0
		—	—	BFB	BFA	MD3	MD2	MD1	MD0
Initial value	:	1	1	0	0	0	0	0	0
Read/Write	:	—	—	R/W	R/W	R/W	R/W	R/W	R/W

Mode

0	0	0	0	Normal operation
			1	Reserved
		1	0	PWM mode 1
			1	PWM mode 2
	1	0	0	Phase counting mode 1
			1	Phase counting mode 2
		1	0	Phase counting mode 3
			1	Phase counting mode 4
1			—	

: Don't care

Notes: 1. MD3 is a reserved bit. In a write, it should always be written with 0.

2. Phase counting mode cannot be set for channels 0 and 3. In this case, 0 should always be written to MD2.

TGRA Buffer Operation

0	TGRA operates normally
1	TGRA and TGRC used together for buffer operation

TGRB Buffer Operation

0	TGRB operates normally
1	TGRB and TGRD used together for buffer operation

TIOR0H—Timer I/O Control Register 0H

H'FFD2

TPU0

Bit	:	7	6	5	4	3	2	1	0
		IOB3	IOB2	IOB1	IOB0	IOA3	IOA2	IOA1	IOA0
Initial value :		0	0	0	0	0	0	0	0
Read/Write :		R/W	R/W	R/W	R/W	R/W	R/W	R/W	R/W

TGR0A I/O Control

0	0	0	0	0	TGR0A is output compare register	Output disabled					
						1	0	0	Initial output is 0 output	0 output at compare match	
									1	1 output at compare match	
	1	0	0	0		0	Output disabled				
							1	0	0	Initial output is 1 output	0 output at compare match
										1	1 output at compare match
1	0	0	0	0	TGR0A is input capture register	Capture input source is TIOCA0 pin	Input capture at rising edge				
							1	0	0	Input capture at falling edge	
										1	1
	1	0	0	0		0	Capture input source is channel 1/count clock	Input capture at TCNT1 count-up/count-down			

TGR0B I/O Control

0	0	0	0	TGR0B is output compare register	Output disabled						
					1	0	0	Initial output is 0 output	0 output at compare match		
								1	1 output at compare match		
	1	0	0		0	0	Output disabled				
							1	0	0	Initial output is 0 output	0 output at compare match
										1	1 output at compare match
1	0	0	0	TGR0B is input capture register	Capture input source is TIOCB0 pin	Input capture at rising edge					
						1	0	0	Input capture at falling edge		
									1	1	Input capture at both edges
	1	0	0		0	0	Capture input source is channel 1/count clock	Input capture at TCNT1 count-up/count-down*			

: Don't care

: Don't care

Note: * When bits TPSC2 to TPSC0 in TCR1 are set to B'000, and $\phi/1$ is used as the TCNT1 count clock, this setting is invalid and input capture does not occur.

TIOR0L—Timer I/O Control Register 0L

H'FFD3

TPU0

Bit	:	7	6	5	4	3	2	1	0
	:	IOD3	IOD2	IOD1	IOD0	IOC3	IOC2	IOC1	IOC0
Initial value	:	0	0	0	0	0	0	0	0
Read/Write	:	R/W	R/W	R/W	R/W	R/W	R/W	R/W	R/W

TGR0C I/O Control

0	0	0	0	TGR0C is output compare register *1	Output disabled				
					1	0	Initial output is 0 output	0 output at compare match	
							1 output at compare match	Toggle output at compare match	
		1	0		0	Output disabled			
						1	0	Initial output is 1 output	0 output at compare match
								1 output at compare match	Toggle output at compare match
	1	0	0	TGR0C is input capture register *	Capture input source is TIOCC0 pin				
					1	0	Input capture at rising edge	Input capture at falling edge	
							1	0	Input capture at both edges
		1	0		0	Capture input source is channel 1/count clock			
						1	0	Input capture at TCNT1 count-up/	count-down
								1	0

: Don't care

Note: * When the BFA bit in TMDR0 is set to 1 and TGR0C is used as a buffer register, this setting is invalid and input capture/output compare does not occur.

TGR0D I/O Control

0	0	0	0	TGR0D is output compare register *2	Output disabled				
					1	0	Initial output is 0 output	0 output at compare match	
							1 output at compare match	Toggle output at compare match	
		1	0		0	Output disabled			
						1	0	Initial output is 1 output	0 output at compare match
								1 output at compare match	Toggle output at compare match
	1	0	0	TGR0D is input capture register *2	Capture input source is TIOCD0 pin				
					1	0	Input capture at rising edge	Input capture at falling edge	
							1	0	Input capture at both edges
		1	0		0	Capture input source is channel 1/count clock			
						1	0	Input capture at TCNT1 count-up/	count-down*1
								1	0

: Don't care

- Notes:
1. When bits TPSC2 to TPSC0 in TCR1 are set to B'000, and ϕ /1 is used as the TCNT1 count clock, this setting is invalid and input capture does not occur.
 2. When the BFB bit in TMDR0 is set to 1 and TGR0D is used as a buffer register, this setting is invalid and input capture/output compare does not occur.

Note: When TGRC or TGRD is designated for buffer operation, this setting is invalid and the register operates as a buffer register.

TIER0—Timer Interrupt Enable Register 0**H'FFD4****TPU0**

Bit	:	7	6	5	4	3	2	1	0
		TTGE	—	—	TCIEV	TGIED	TGIEC	TGIEB	TGIEA
Initial value	:	0	1	0	0	0	0	0	0
Read/Write	:	R/W	—	—	R/W	R/W	R/W	R/W	R/W

TGR Interrupt Enable A

0	Interrupt request (TGIA) by TGFA bit disabled
1	Interrupt request (TGIA) by TGFA bit enabled

TGR Interrupt Enable B

0	Interrupt request (TGIB) by TGFB bit disabled
1	Interrupt request (TGIB) by TGFB bit enabled

TGR Interrupt Enable C

0	Interrupt request (TGIC) by TGFC bit disabled
1	Interrupt request (TGIC) by TGFC bit enabled

TGR Interrupt Enable D

0	Interrupt request (TGID) by TGFD bit disabled
1	Interrupt request (TGID) by TGFD bit enabled

Overflow Interrupt Enable

0	Interrupt request (TCIV) by TCFV disabled
1	Interrupt request (TCIV) by TCFV enabled

A/D Conversion Start Request Enable

0	A/D conversion start request generation disabled
1	A/D conversion start request generation enabled

TSR0—Timer Status Register 0

H'FFD5

TPU0

Bit	7	6	5	4	3	2	1	0
	—	—	—	TCFV	TGFD	TGFC	TGFB	TGFA
Initial value	1	1	0	0	0	0	0	0
Read/Write	—	—	—	R/(W)*	R/(W)*	R/(W)*	R/(W)*	R/(W)*

Input Capture/Output Compare Flag A

0	[Clearing conditions] <ul style="list-style-type: none"> When DTC is activated by TGIA interrupt while DISEL bit of MRB in DTC is 0 When 0 is written to TGFA after reading TGFA = 1
1	[Setting conditions] <ul style="list-style-type: none"> When TCNT = TGRA while TGRA is functioning as output compare register When TCNT value is transferred to TGRA by input capture signal while TGRA is functioning as input capture register

Input Capture/Output Compare Flag B

0	[Clearing conditions] <ul style="list-style-type: none"> When DTC is activated by TGIB interrupt while DISEL bit of MRB in DTC is 0 When 0 is written to TGFB after reading TGFB = 1
1	[Setting conditions] <ul style="list-style-type: none"> When TCNT = TGRB while TGRB is functioning as output compare register When TCNT value is transferred to TGRB by input capture signal while TGRB is functioning as input capture register

Input Capture/Output Compare Flag C

0	[Clearing conditions] <ul style="list-style-type: none"> When DTC is activated by TGIC interrupt while DISEL bit of MRB in DTC is 0 When 0 is written to TGFC after reading TGFC = 1
1	[Setting conditions] <ul style="list-style-type: none"> When TCNT = TGRC while TGRC is functioning as output compare register When TCNT value is transferred to TGRC by input capture signal while TGRC is functioning as input capture register

Input Capture/Output Compare Flag D

0	[Clearing conditions] <ul style="list-style-type: none"> When DTC is activated by TGID interrupt while DISEL bit of MRB in DTC is 0 When 0 is written to TGFD after reading TGFD = 1
1	[Setting conditions] <ul style="list-style-type: none"> When TCNT = TGRD while TGRD is functioning as output compare register When TCNT value is transferred to TGRD by input capture signal while TGRD is functioning as input capture register

Overflow Flag

0	[Clearing condition] <ul style="list-style-type: none"> When 0 is written to TCFV after reading TCFV = 1
1	[Setting condition] <ul style="list-style-type: none"> When the TCNT value overflows (changes from H'FFFF to H'0000)

Note: * Can only be written with 0 for flag clearing.

TCNT0—Timer Counter 0

H'FFD6

TPU0

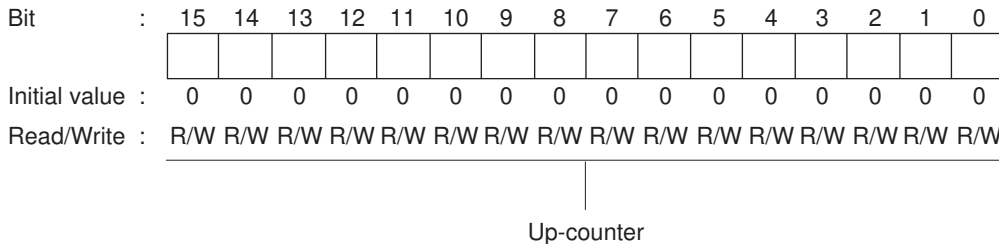

TGR0A—Timer General Register 0A

H'FFD8

TPU0

TGR0B—Timer General Register 0B

H'FFDA

TPU0

TGR0C—Timer General Register 0C

H'FFDC

TPU0

TGR0D—Timer General Register 0D

H'FFDE

TPU0

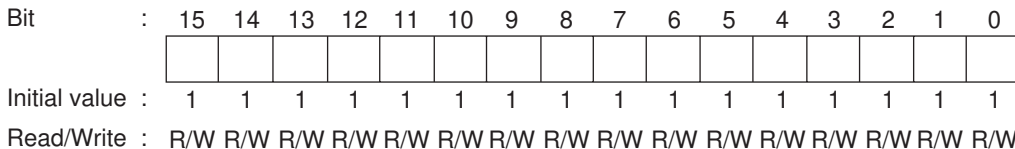

TCR1—Timer Control Register 1

H'FFE0

TPU1

Bit	:	7	6	5	4	3	2	1	0
		—	CCLR1	CCLR0	CKEG1	CKEG0	TPSC2	TPSC1	TPSC0
Initial value	:	0	0	0	0	0	0	0	0
Read/Write	:	—	R/W	R/W	R/W	R/W	R/W	R/W	R/W

Time Prescaler

0	0	0	Internal clock: counts on $\phi/1$
		1	Internal clock: counts on $\phi/4$
	1	0	Internal clock: counts on $\phi/16$
		1	Internal clock: counts on $\phi/64$
1	0	0	External clock: counts on TCLKA pin input
		1	External clock: counts on TCLKB pin input
	1	0	Internal clock: counts on $\phi/256$
		1	Counts on TCNT2 overflow/underflow

Note: This setting is ignored when channel 1 is in phase counting mode.

Clock Edge*

0	0	Count at rising edge
	1	Count at falling edge
1	—	Count at both edges

Note: * This setting is ignored when channel 1 is in phase counting mode.
The internal clock edge selection is valid when the input clock is $\phi/4$ or slower. This setting is ignored if $\phi/1$ or overflow/underflow on another channel is selected as the input clock.

Counter Clear

0	0	TCNT clearing disabled
	1	TCNT cleared by TGRA compare match/input capture
1	0	TCNT cleared by TGRB compare match/input capture
	1	TCNT cleared by counter clearing for another channel performing synchronous clearing/synchronous operation*

Note: * Synchronous operation setting is performed by setting the SYNC bit in TSYR to 1.

TMDR1—Timer Mode Register 1**H'FFE1****TPU1**

Bit	:	7	6	5	4	3	2	1	0
		—	—	—	—	MD3	MD2	MD1	MD0
Initial value	:	1	1	0	0	0	0	0	0
Read/Write	:	—	—	—	—	R/W	R/W	R/W	R/W

Mode

0	0	0	0	Normal operation	
			1	Reserved	
		1	0	0	PWM mode 1
				1	PWM mode 2
	1	0	0	Phase counting mode 1	
			1	Phase counting mode 2	
		1	0	0	Phase counting mode 3
				1	Phase counting mode 4
1				—	

: Don't care

Note: MD3 is a reserved bit. In a write, it should always be written with 0.

TIOR1—Timer I/O Control Register 1

H'FFE2

TPU1

Bit	:	7	6	5	4	3	2	1	0
		IOB3	IOB2	IOB1	IOB0	IOA3	IOA2	IOA1	IOA0
Initial value	:	0	0	0	0	0	0	0	0
Read/Write	:	R/W	R/W	R/W	R/W	R/W	R/W	R/W	R/W

TGR1A I/O Control

0	0	0	0	TGR1A is output compare register	Output disabled				
					1	0	Initial output is 0 output	0 output at compare match	
							1 output at compare match		
		1	0		0	Toggle output at compare match			
						1	0	Output disabled	
								Initial output is 1 output	0 output at compare match
	1 output at compare match	Toggle output at compare match							
	1	0	0	TGR1A is input capture register	Input capture at rising edge				
					1	0	Input capture at falling edge		
							1	Input capture at both edges	
		1	0		0	Input capture at generation of channel 0/TGR0A compare match/ input capture			
						1	0	Input capture at rising edge	
1								Input capture at falling edge	
1	Input capture at both edges								

: Don't care

TGR1B I/O Control

0	0	0	TGR1B is output compare register	Output disabled					
				1	0	Initial output is 0 output	0 output at compare match		
						1 output at compare match	Toggle output at compare match		
		1		0	0	Output disabled			
						1	0	Initial output is 1 output	0 output at compare match
								1 output at compare match	Toggle output at compare match
	1	0	TGR1B is input capture register	Input capture at rising edge					
				1	0	Input capture at falling edge			
						1	Input capture at both edges		
		1		0	0	Input capture at generation of TGR0C compare match/ input capture			
						1	0	Input capture at rising edge	
								1	Input capture at falling edge
1	Input capture at both edges								

: Don't care

TIER1—Timer Interrupt Enable Register 1**H'FFE4****TPU1**

Bit	:	7	6	5	4	3	2	1	0
		TTGE	—	TCIEU	TCIEV	—	—	TGIEB	TGIEA
Initial value	:	0	1	0	0	0	0	0	0
Read/Write	:	R/W	—	R/W	R/W	—	—	R/W	R/W

TGR Interrupt Enable A

0	Interrupt request (TGIA) by TGFA bit disabled
1	Interrupt request (TGIA) by TGFA bit enabled

TGR Interrupt Enable B

0	Interrupt request (TGIB) by TGFB bit disabled
1	Interrupt request (TGIB) by TGFB bit enabled

Overflow Interrupt Enable

0	Interrupt request (TCIV) by TCFV disabled
1	Interrupt request (TCIV) by TCFV enabled

Underflow Interrupt Enable

0	Interrupt request (TCIU) by TCFU disabled
1	Interrupt request (TCIU) by TCFU enabled

A/D Conversion Start Request Enable

0	A/D conversion start request generation disabled
1	A/D conversion start request generation enabled

TSR1—Timer Status Register 1

H'FFE5

TPU1

Bit	:	7	6	5	4	3	2	1	0
		TCFD	—	TCFU	TCFV	—	—	TGFB	TGFA
Initial value	:	1	1	0	0	0	0	0	0
Read/Write	:	R	—	R/(W)*	R/(W)*	—	—	R/(W)*	R/(W)*

Input Capture/Output Compare Flag A

0	[Clearing conditions] <ul style="list-style-type: none"> When DTC is activated by TGIA interrupt while DISEL bit of MRB in DTC is 0 When 0 is written to TGFA after reading TGFA = 1
1	[Setting conditions] <ul style="list-style-type: none"> When TCNT = TGRA while TGRA is functioning as output compare register When TCNT value is transferred to TGRA by input capture signal while TGRA is functioning as input capture register

Input Capture/Output Compare Flag B

0	[Clearing conditions] <ul style="list-style-type: none"> When DTC is activated by TGIB interrupt while DISEL bit of MRB in DTC is 0 When 0 is written to TGFB after reading TGFB = 1
1	[Setting conditions] <ul style="list-style-type: none"> When TCNT = TGRB while TGRB is functioning as output compare register When TCNT value is transferred to TGRB by input capture signal while TGRB is functioning as input capture register

Overflow Flag

0	[Clearing condition] When 0 is written to TCFV after reading TCFV = 1
1	[Setting condition] When the TCNT value overflows (changes from H'FFFF to H'0000)

Underflow Flag

0	[Clearing condition] When 0 is written to TCFU after reading TCFU = 1
1	[Setting condition] When the TCNT value underflows (changes from H'0000 to H'FFFF)

Count Direction Flag

0	TCNT counts down
1	TCNT counts up

Note: * Can only be written with 0 for flag clearing.

TCNT1—Timer Counter 1

H'FFE6

TPU1

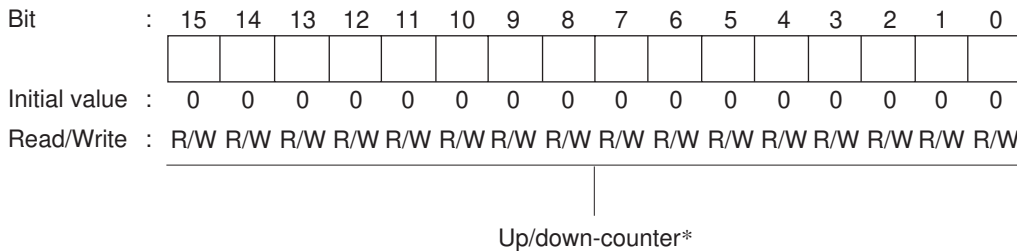

Note: * This timer counter can be used as an up/down-counter only in phase counting mode or when performing overflow/underflow counting on another channel. In other cases it functions as an up-counter.

TGR1A—Timer General Register 1A

H'FFE8

TPU1

TGR1B—Timer General Register 1B

H'FFEA

TPU1

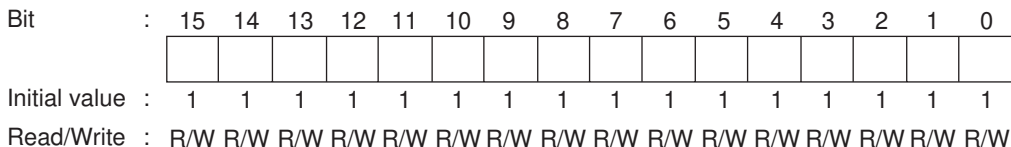

TCR2—Timer Control Register 2

H'FFF0

TPU2

Bit	:	7	6	5	4	3	2	1	0
		—	CCLR1	CCLR0	CKEG1	CKEG0	TPSC2	TPSC1	TPSC0
Initial value	:	0	0	0	0	0	0	0	0
Read/Write	:	—	R/W	R/W	R/W	R/W	R/W	R/W	R/W

Time Prescaler

0	0	0	Internal clock: counts on $\phi/1$
		1	Internal clock: counts on $\phi/4$
	1	0	Internal clock: counts on $\phi/16$
		1	Internal clock: counts on $\phi/64$
1	0	0	External clock: counts on TCLKA pin input
		1	External clock: counts on TCLKB pin input
	1	0	External clock: counts on TCLKC pin input
		1	Internal clock: counts on $\phi/1024$

Note: This setting is ignored when channel 2 is in phase counting mode.

Clock Edge*

0	0	Count at rising edge
	1	Count at falling edge
1	—	Count at both edges

Note: * This setting is ignored when channel 2 is in phase counting mode.
The internal clock edge selection is valid when the input clock is $\phi/4$ or slower. This setting is ignored if $\phi/1$ or overflow/underflow on another channel is selected as the input clock.

Counter Clear

0	0	TCNT clearing disabled
	1	TCNT cleared by TGRA compare match/input capture
1	0	TCNT cleared by TGRB compare match/input capture
	1	TCNT cleared by counter clearing for another channel performing synchronous clearing/synchronous operation*

Note: * Synchronous operation setting is performed by setting the SYNC bit in TSYR to 1.

TMDR2—Timer Mode Register 2**H'FFF1****TPU2**

Bit	:	7	6	5	4	3	2	1	0
		—	—	—	—	MD3	MD2	MD1	MD0
Initial value	:	1	1	0	0	0	0	0	0
Read/Write	:	—	—	—	—	R/W	R/W	R/W	R/W

Mode

0	0	0	0	Normal operation
			1	Reserved
		1	0	PWM mode 1
			1	PWM mode 2
	1	0	0	Phase counting mode 1
			1	Phase counting mode 2
		1	0	Phase counting mode 3
			1	Phase counting mode 4
1			—	

: Don't care

Note: MD3 is a reserved bit. In a write, it should always be written with 0.

TIOR2—Timer I/O Control Register 2

H'FFF2

TPU2

Bit	:	7	6	5	4	3	2	1	0
		IOB3	IOB2	IOB1	IOB0	IOA3	IOA2	IOA1	IOA0
Initial value :		0	0	0	0	0	0	0	0
Read/Write :		R/W	R/W	R/W	R/W	R/W	R/W	R/W	R/W

TGR2A I/O Control

0	0	0	0	TGR2A is output compare register	Output disabled			
					1	0	Initial output is 0 output	0 output at compare match
							1 output at compare match	
		1	0		0	Toggle output at compare match		
						1	0	Output disabled
								1
	1 output at compare match							
	Toggle output at compare match							
	1	0	0	TGR2A is input capture register	Capture input source is TIOCA2 pin	Input capture at rising edge		
					1	0	Input capture at falling edge	
							1	Input capture at both edges

: Don't care

TGR2B I/O Control

0	0	0	0	TGR2B is output compare register	Output disabled			
					1	0	Initial output is 0 output	0 output at compare match
							1 output at compare match	
		1	0		0	Toggle output at compare match		
						1	0	Output disabled
								1
	1 output at compare match							
	Toggle output at compare match							
	1	0	0	TGR2B is input capture register	Capture input source is TIOCB2 pin	Input capture at rising edge		
					1	0	Input capture at falling edge	
							1	Input capture at both edges

: Don't care

TIER2—Timer Interrupt Enable Register 2**H'FFF4****TPU2**

Bit	7	6	5	4	3	2	1	0
	TTGE	—	TCIEU	TCIEV	—	—	TGIEB	TGIEA
Initial value	0	1	0	0	0	0	0	0
Read/Write	R/W	—	R/W	R/W	—	—	R/W	R/W

TGR Interrupt Enable A	
0	Interrupt request (TGIA) by TGFA bit disabled
1	Interrupt request (TGIA) by TGFA bit enabled

TGR Interrupt Enable B	
0	Interrupt request (TGIB) by TGFB bit disabled
1	Interrupt request (TGIB) by TGFB bit enabled

Overflow Interrupt Enable	
0	Interrupt request (TCIV) by TCFV disabled
1	Interrupt request (TCIV) by TCFV enabled

Underflow Interrupt Enable	
0	Interrupt request (TCIU) by TCFU disabled
1	Interrupt request (TCIU) by TCFU enabled

A/D Conversion Start Request Enable	
0	A/D conversion start request generation disabled
1	A/D conversion start request generation enabled

TSR2—Timer Status Register 2

H'FFF5

TPU2

Bit	7	6	5	4	3	2	1	0
	TCFD	—	TCFU	TCFV	—	—	TGFB	TGFA
Initial value	1	1	0	0	0	0	0	0
Read/Write	R	—	R/(W)*	R/(W)*	—	—	R/(W)*	R/(W)*

Input Capture/Output Compare Flag A

0	[Clearing conditions] <ul style="list-style-type: none"> When DTC is activated by TGIA interrupt while DISEL bit of MRB in DTC is 0 When 0 is written to TGFA after reading TGFA = 1
1	[Setting conditions] <ul style="list-style-type: none"> When TCNT = TGRA while TGRA is functioning as output compare register When TCNT value is transferred to TGRA by input capture signal while TGRA is functioning as input capture register

Input Capture/Output Compare Flag B

0	[Clearing conditions] <ul style="list-style-type: none"> When DTC is activated by TGIB interrupt while DISEL bit of MRB in DTC is 0 When 0 is written to TGFB after reading TGFB = 1
1	[Setting conditions] <ul style="list-style-type: none"> When TCNT = TGRB while TGRB is functioning as output compare register When TCNT value is transferred to TGRB by input capture signal while TGRB is functioning as input capture register

Overflow Flag

0	[Clearing condition] <ul style="list-style-type: none"> When 0 is written to TCFV after reading TCFV = 1
1	[Setting condition] <ul style="list-style-type: none"> When the TCNT value overflows (changes from H'FFFF to H'0000)

Underflow Flag

0	[Clearing condition] <ul style="list-style-type: none"> When 0 is written to TCFU after reading TCFU = 1
1	[Setting condition] <ul style="list-style-type: none"> When the TCNT value underflows (changes from H'0000 to H'FFFF)

Count Direction Flag

0	TCNT counts down
1	TCNT counts up

Note: * Can only be written with 0 for flag clearing.

TCNT2—Timer Counter 2**H'FFF6****TPU2**

Bit	:	15	14	13	12	11	10	9	8	7	6	5	4	3	2	1	0
		<input type="checkbox"/>	<input type="checkbox"/>	<input type="checkbox"/>	<input type="checkbox"/>	<input type="checkbox"/>	<input type="checkbox"/>	<input type="checkbox"/>	<input type="checkbox"/>	<input type="checkbox"/>	<input type="checkbox"/>	<input type="checkbox"/>	<input type="checkbox"/>	<input type="checkbox"/>	<input type="checkbox"/>	<input type="checkbox"/>	<input type="checkbox"/>
Initial value	:	0	0	0	0	0	0	0	0	0	0	0	0	0	0	0	0
Read/Write	:	R/W	R/W	R/W	R/W	R/W	R/W	R/W	R/W	R/W	R/W	R/W	R/W	R/W	R/W	R/W	R/W

Up/down-counter*

Note: * This timer counter can be used as an up/down-counter only in phase counting mode or when performing overflow/underflow counting on another channel. In other cases it functions as an up-counter.

TGR2A—Timer General Register 2A**H'FFF8****TPU2****TGR2B—Timer General Register 2B****H'FFFA****TPU2**

Bit	:	15	14	13	12	11	10	9	8	7	6	5	4	3	2	1	0
		<input type="checkbox"/>	<input type="checkbox"/>	<input type="checkbox"/>	<input type="checkbox"/>	<input type="checkbox"/>	<input type="checkbox"/>	<input type="checkbox"/>	<input type="checkbox"/>	<input type="checkbox"/>	<input type="checkbox"/>	<input type="checkbox"/>	<input type="checkbox"/>	<input type="checkbox"/>	<input type="checkbox"/>	<input type="checkbox"/>	<input type="checkbox"/>
Initial value	:	1	1	1	1	1	1	1	1	1	1	1	1	1	1	1	1
Read/Write	:	R/W	R/W	R/W	R/W	R/W	R/W	R/W	R/W	R/W	R/W	R/W	R/W	R/W	R/W	R/W	R/W

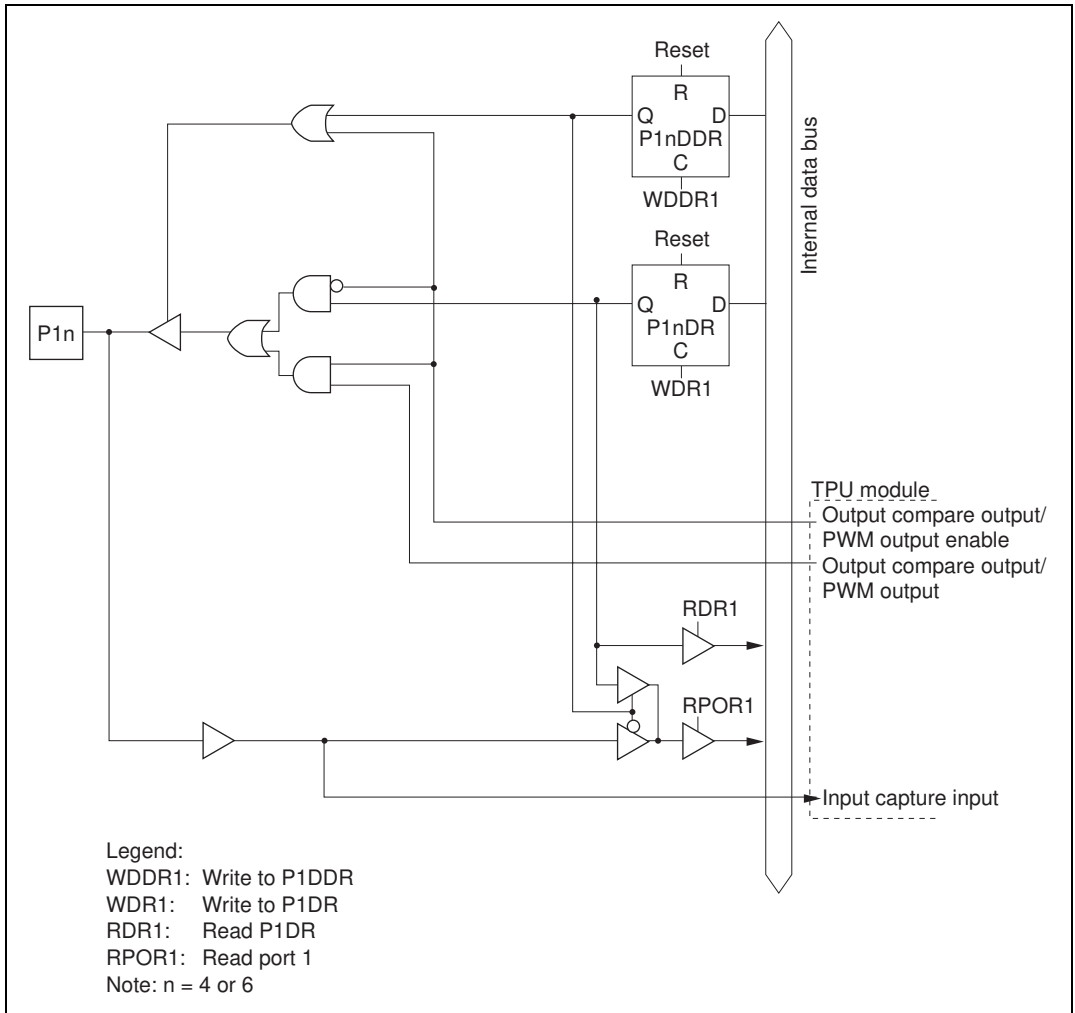

Figure C.1(c) Port 1 Block Diagram (Pins P14 and P16)

C.2 Port 2

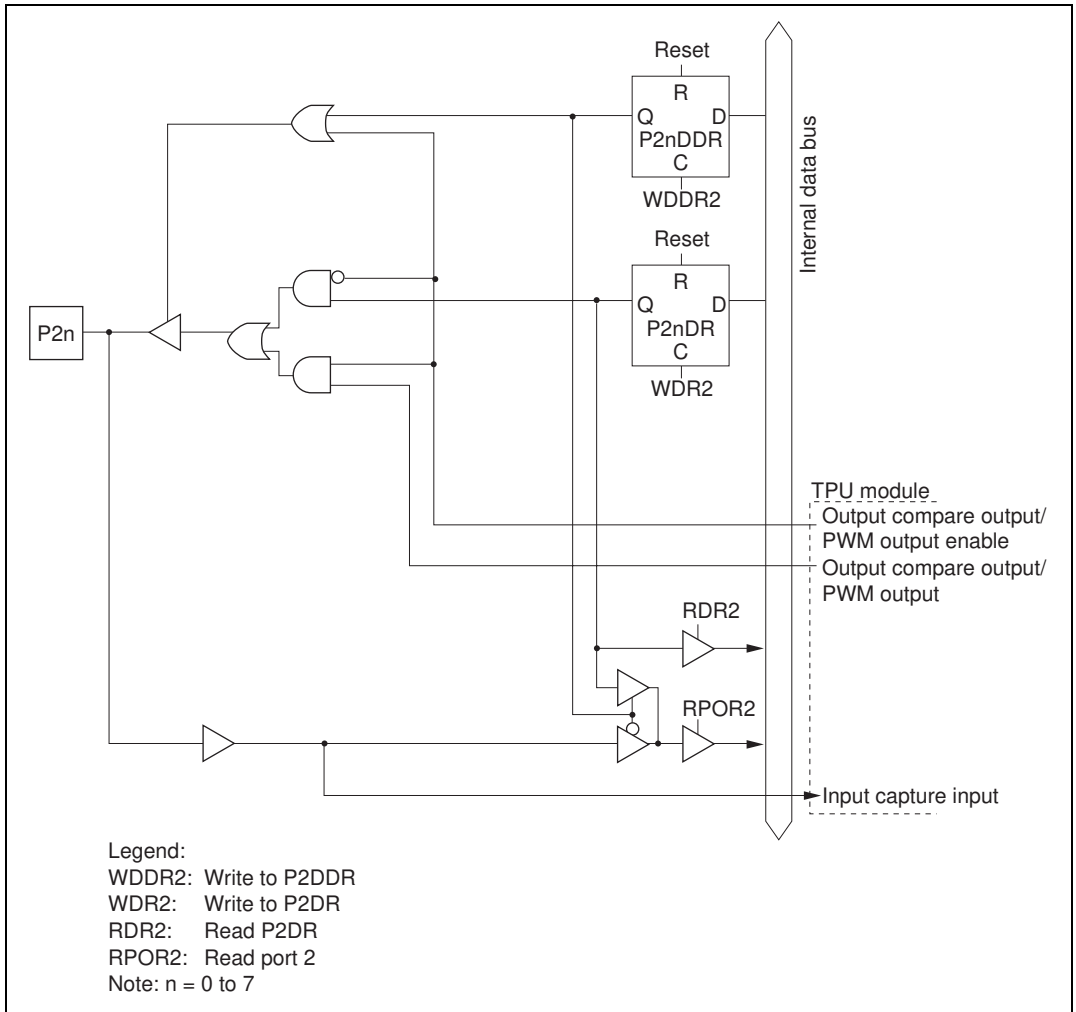

Figure C.2 Port 2 Block Diagram (Pins P20 to P27)

C.3 Port 3

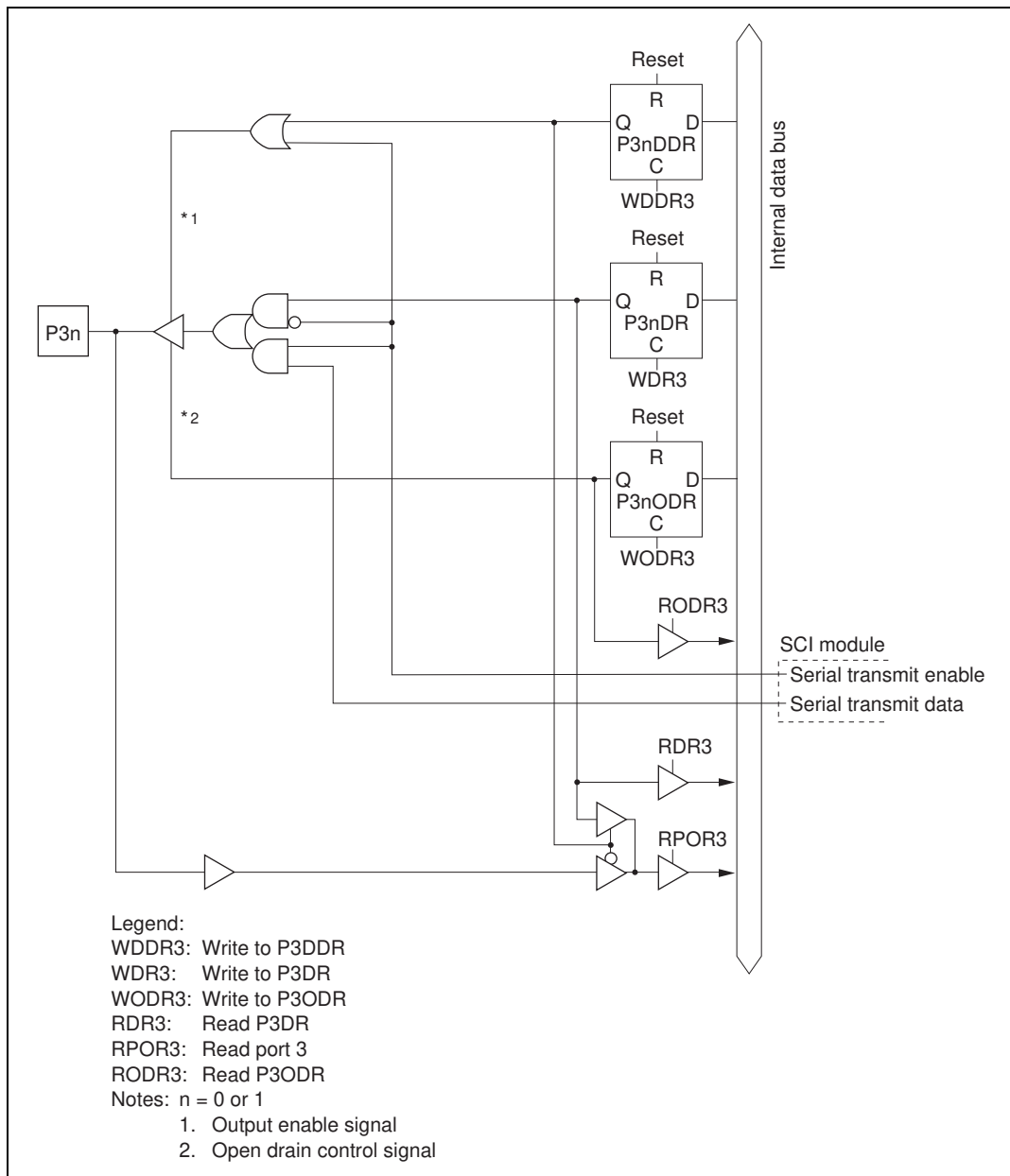

Figure C.3(a) Port 3 Block Diagram (Pins P30 and P31)

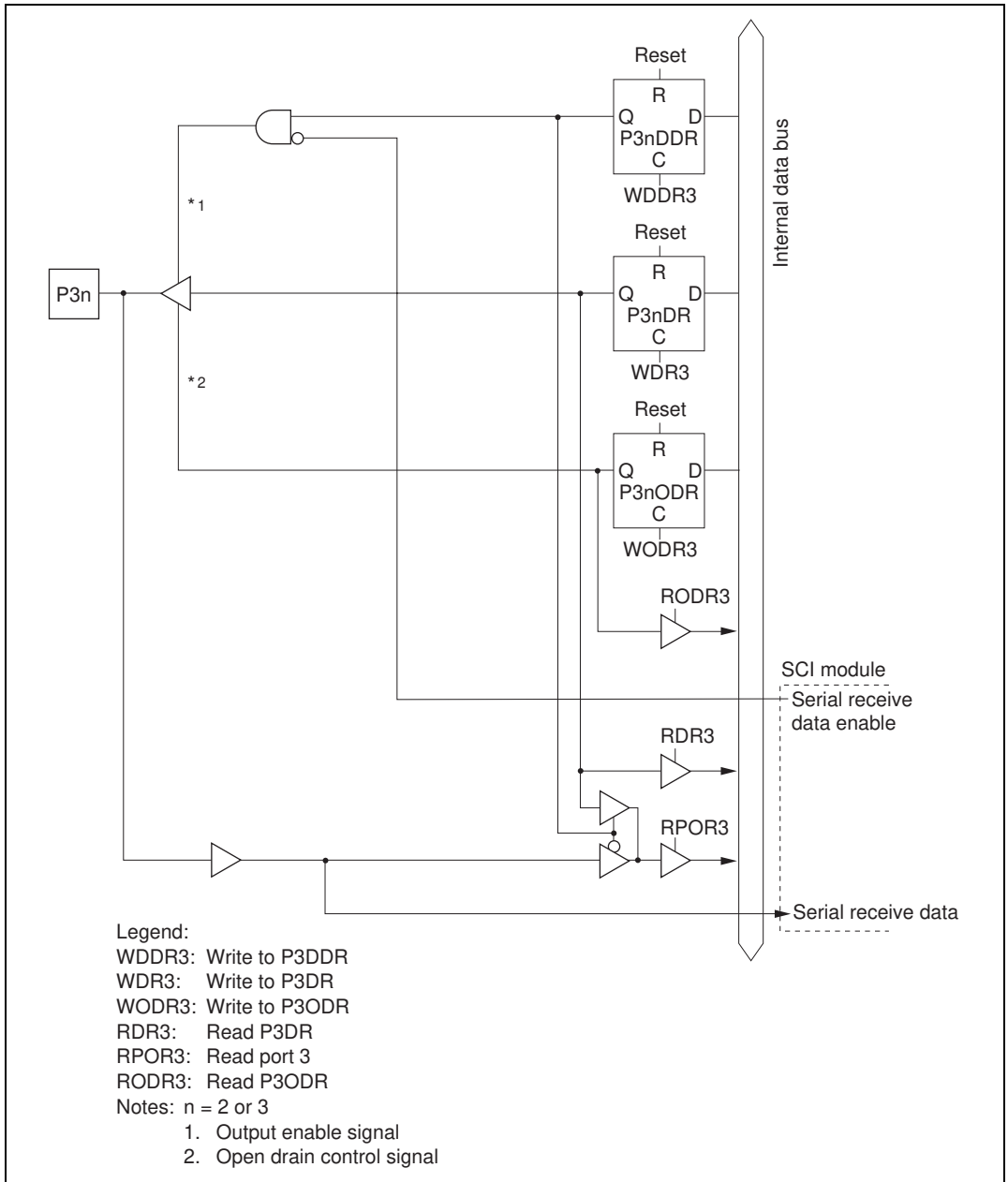

Figure C.3(b) Port 3 Block Diagram (Pins P32 and P33)

C.4 Port 4

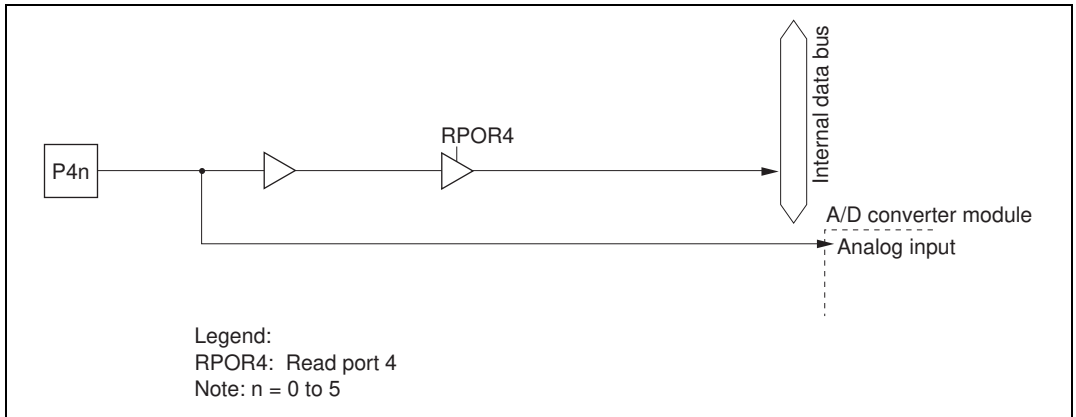

Figure C.4(a) Port 4 Block Diagram (Pins P40 to P45)

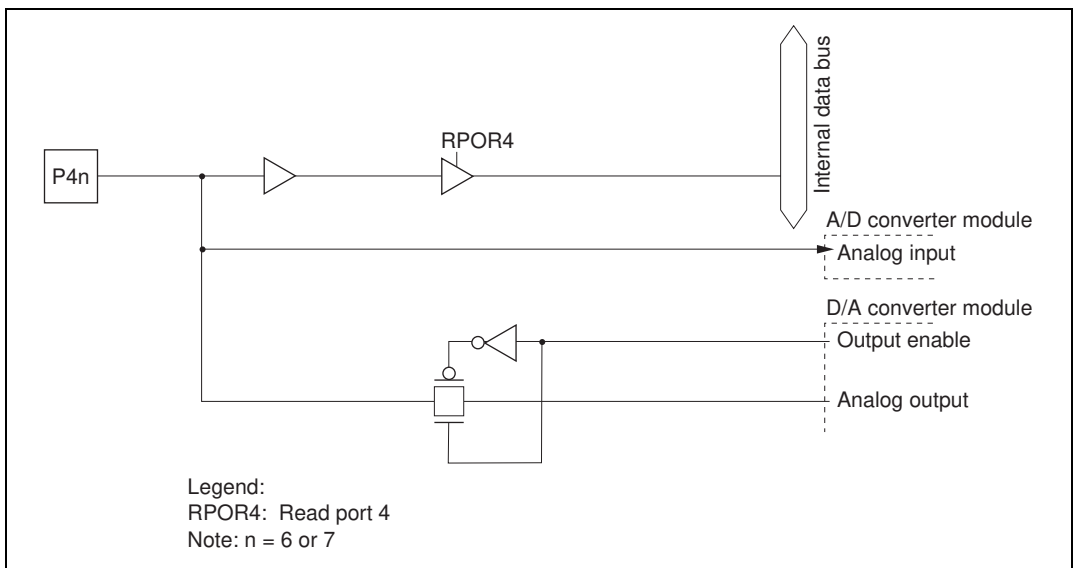

Figure C.4(b) Port 4 Block Diagram (Pins P46 and P47)

C.5 Port A

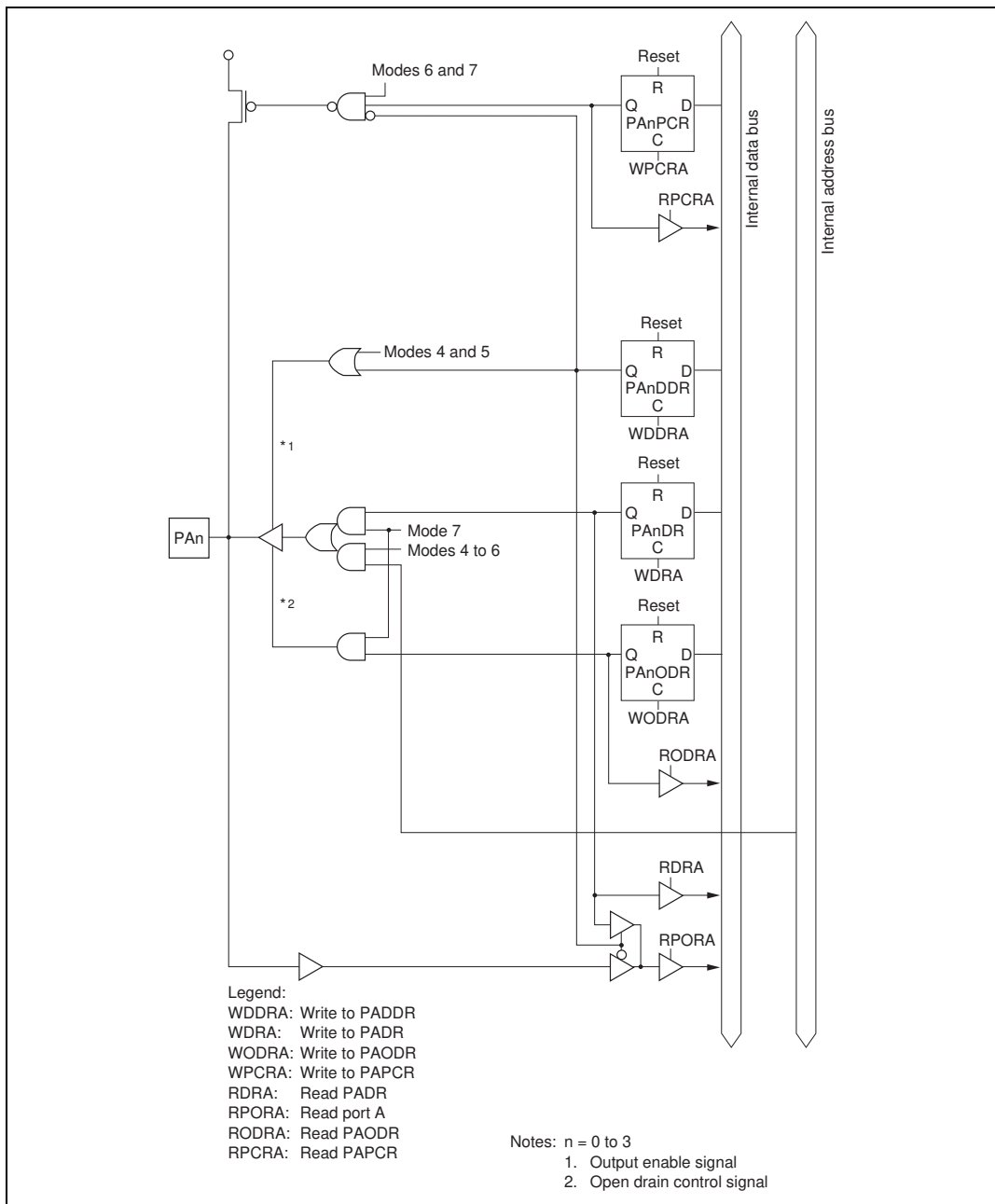

Figure C.5 Port A Block Diagram (Pins PA0 to PA3)

C.6 Port B

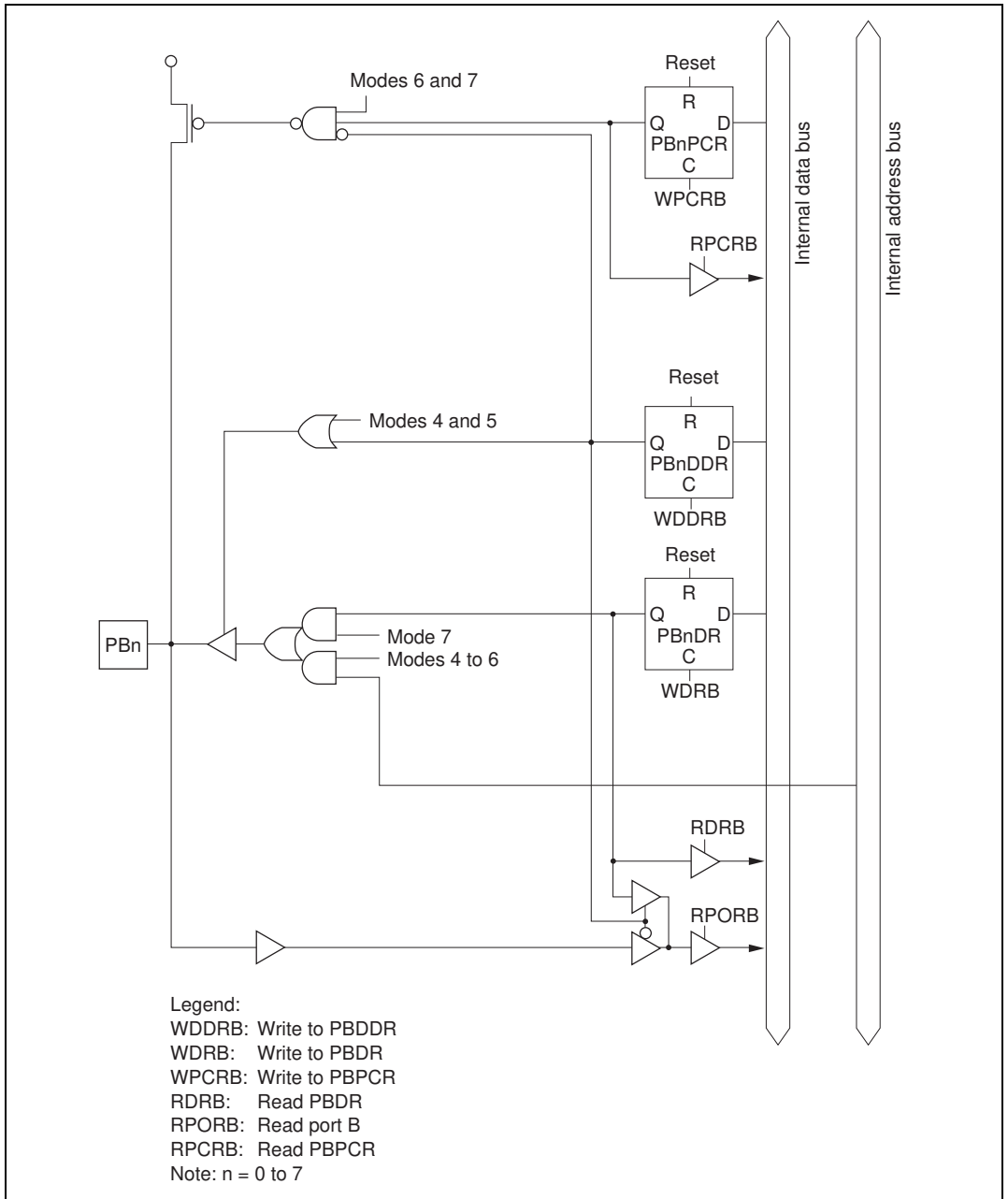

Figure C.6 Port B Block Diagram (Pins PB0 to PB7)

C.7 Port C

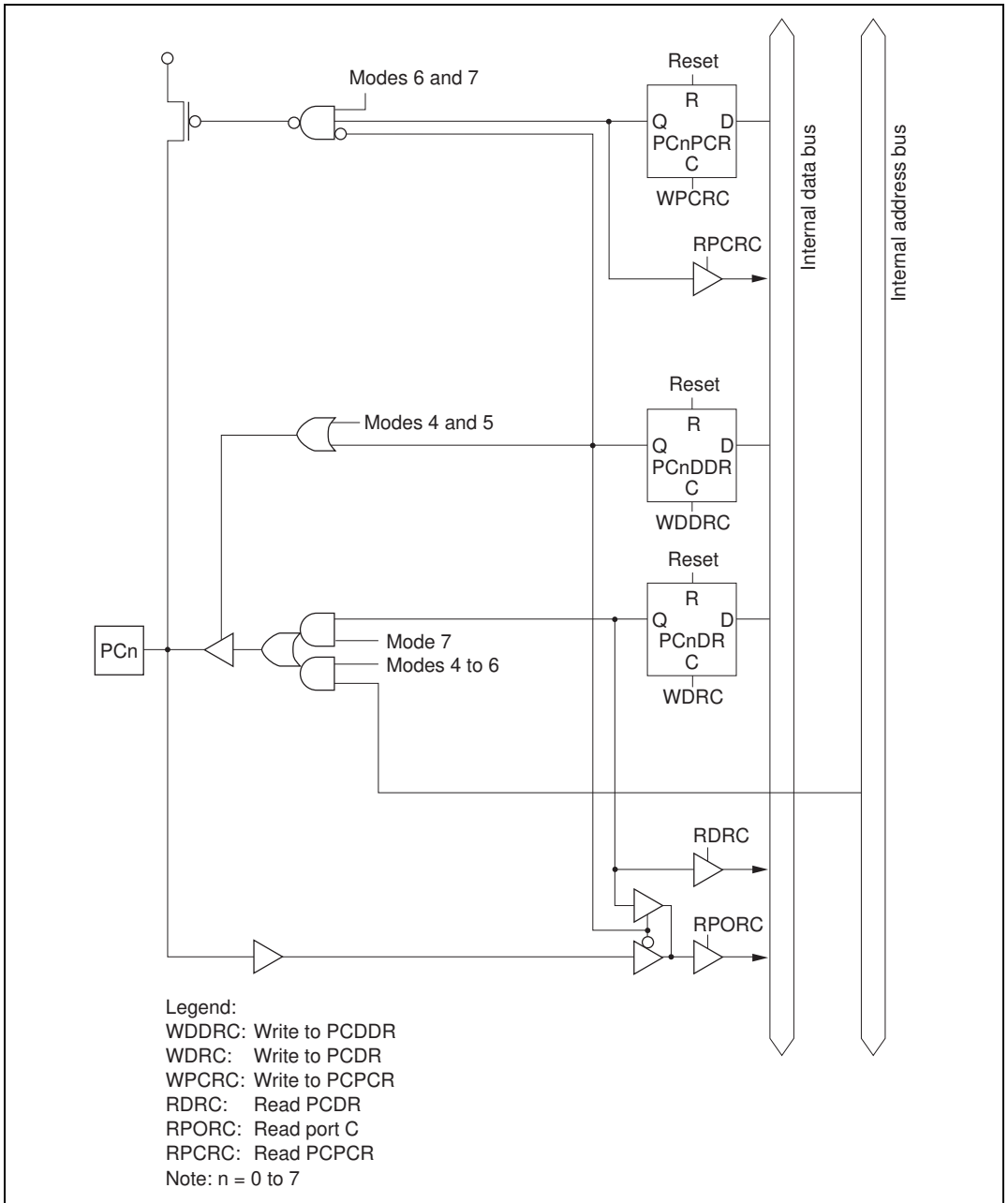

Figure C.7 Port C Block Diagram (Pins PC0 to PC7)

C.8 Port D

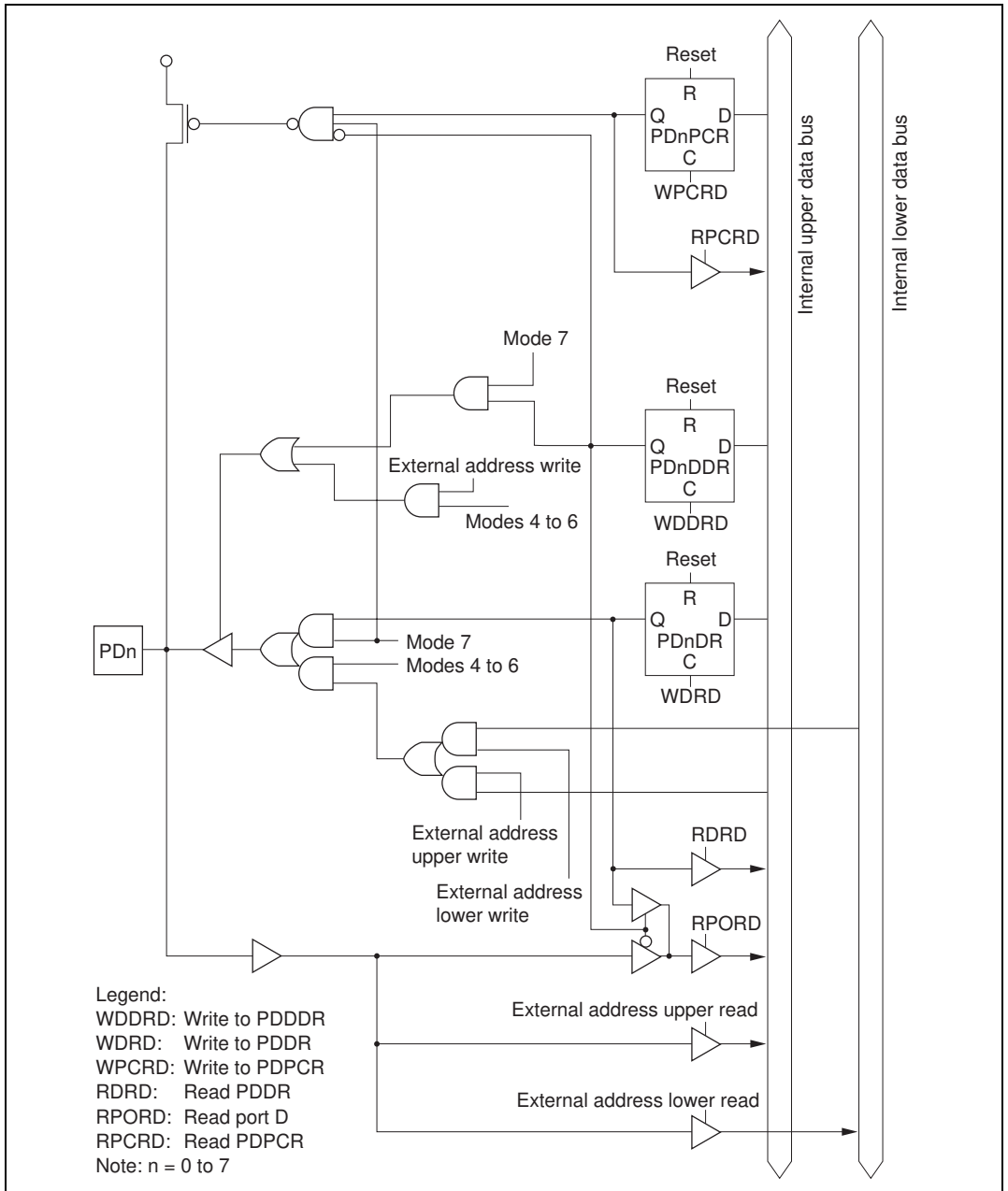

Figure C.8 Port D Block Diagram (Pins PD0 to PD7)

C.9 Port E

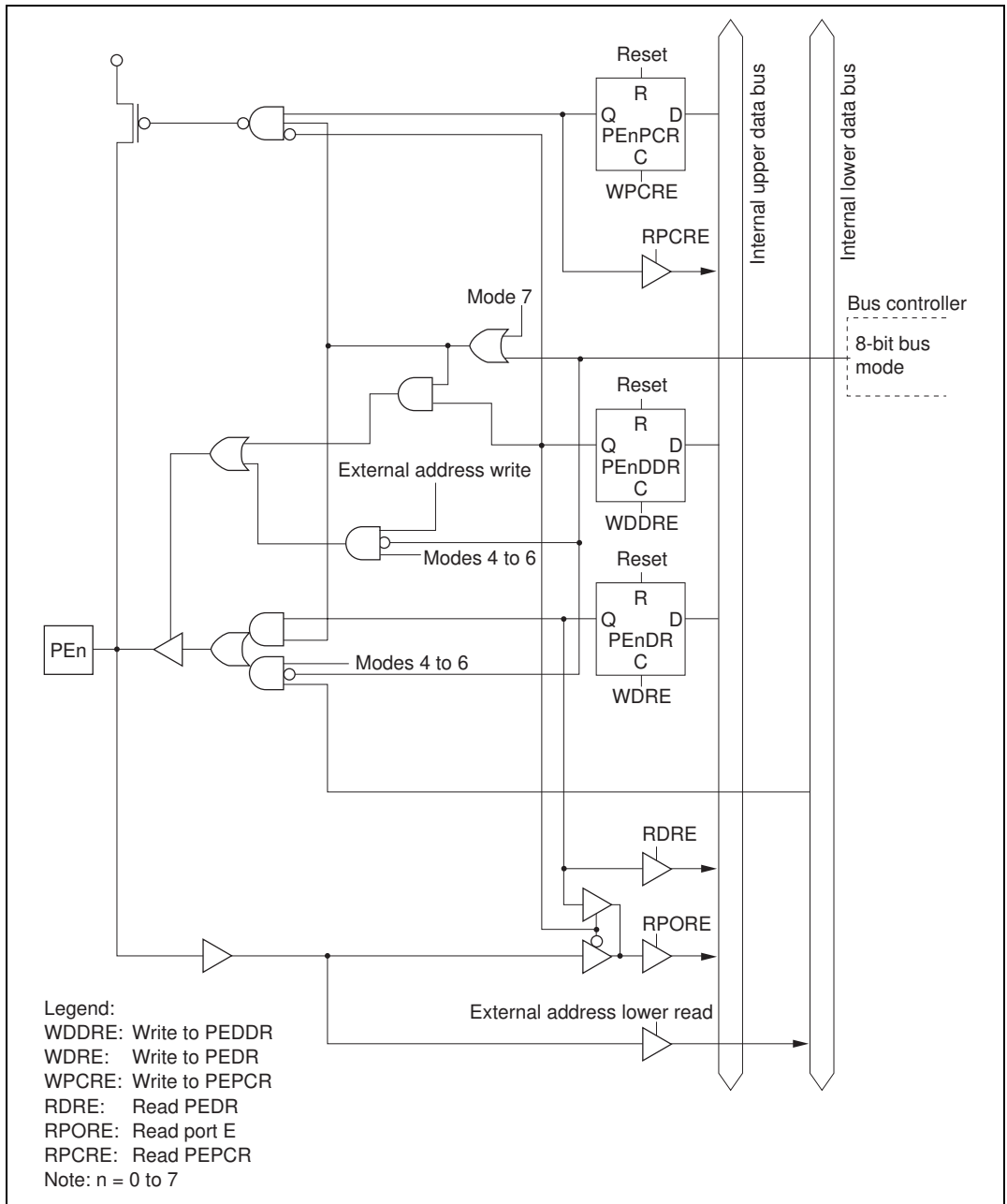

Figure C.9 Port E Block Diagram (Pins PE0 to PE7)

C.10 Port F

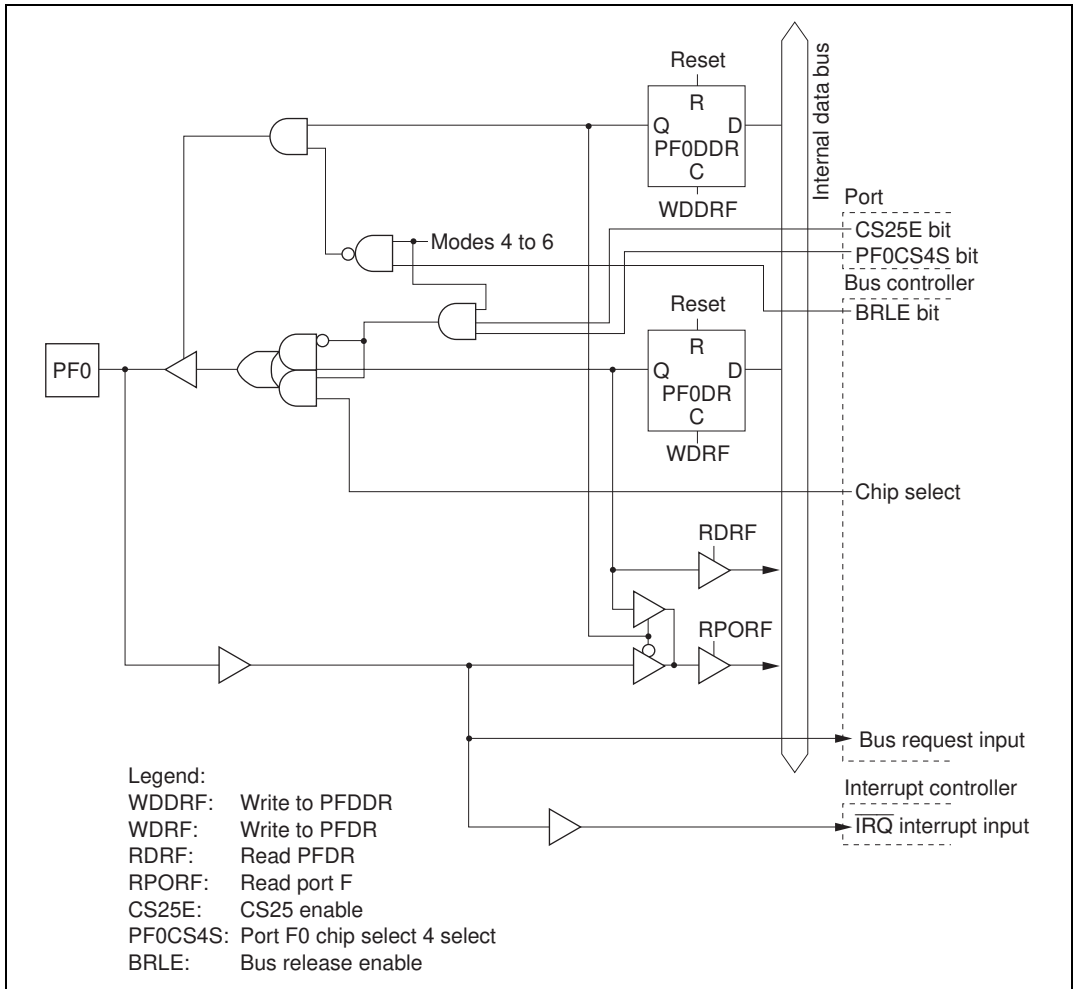

Figure C.10(a) Port F Block Diagram (Pin PF0)

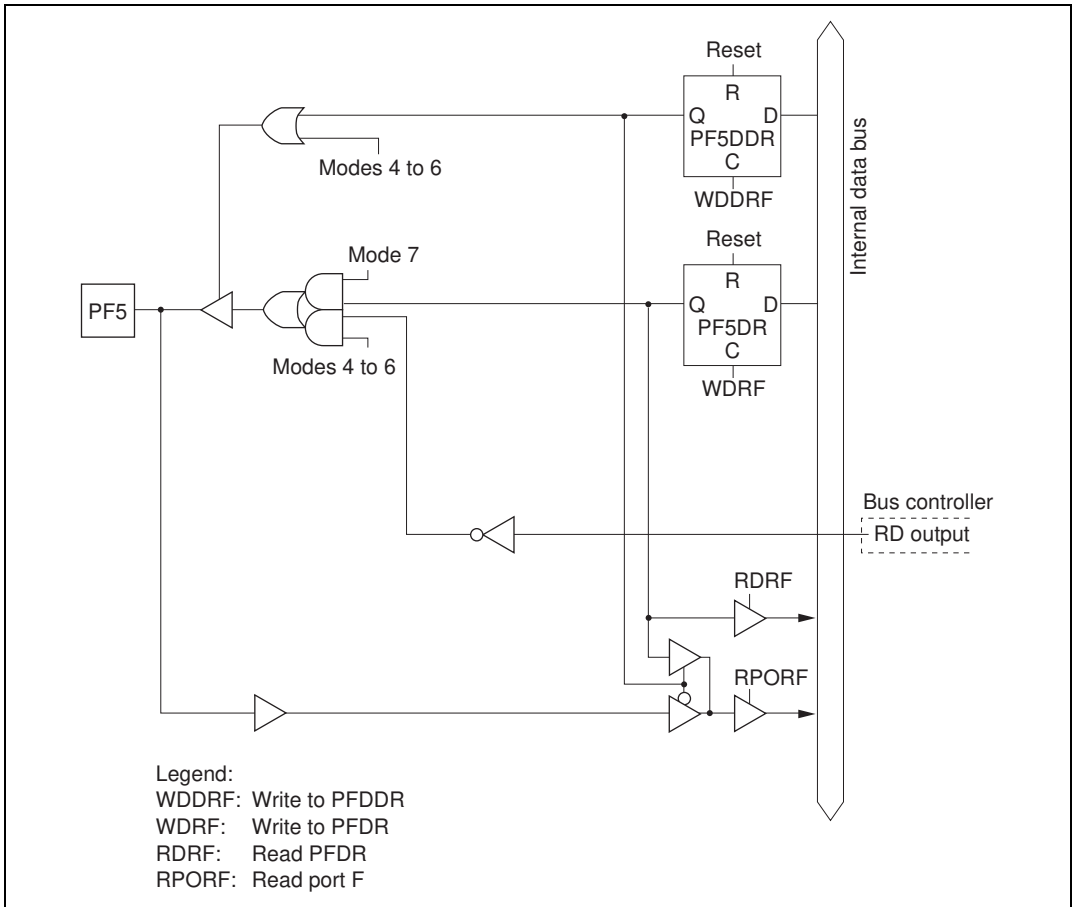

Figure C.10(f) Port F Block Diagram (Pin PF5)

C.11 Port G

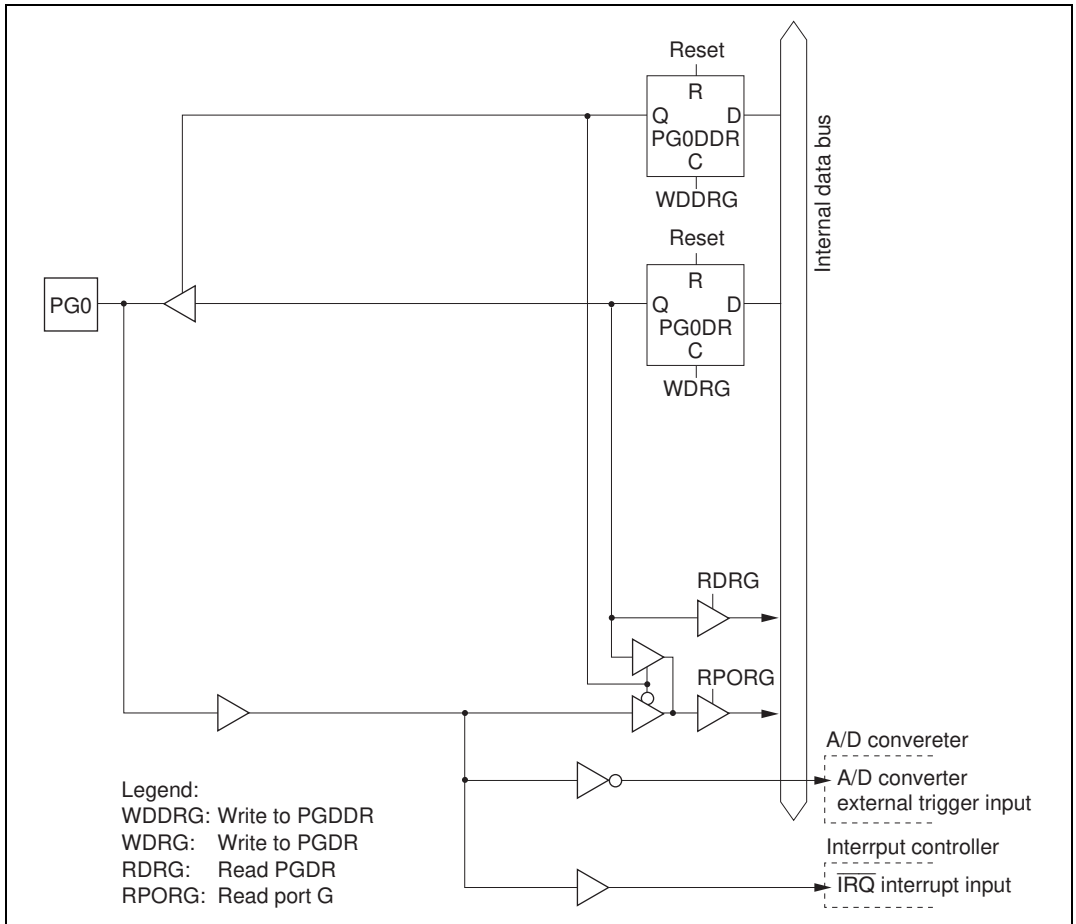

Figure C.11(a) Port G Block Diagram (Pin PG0)

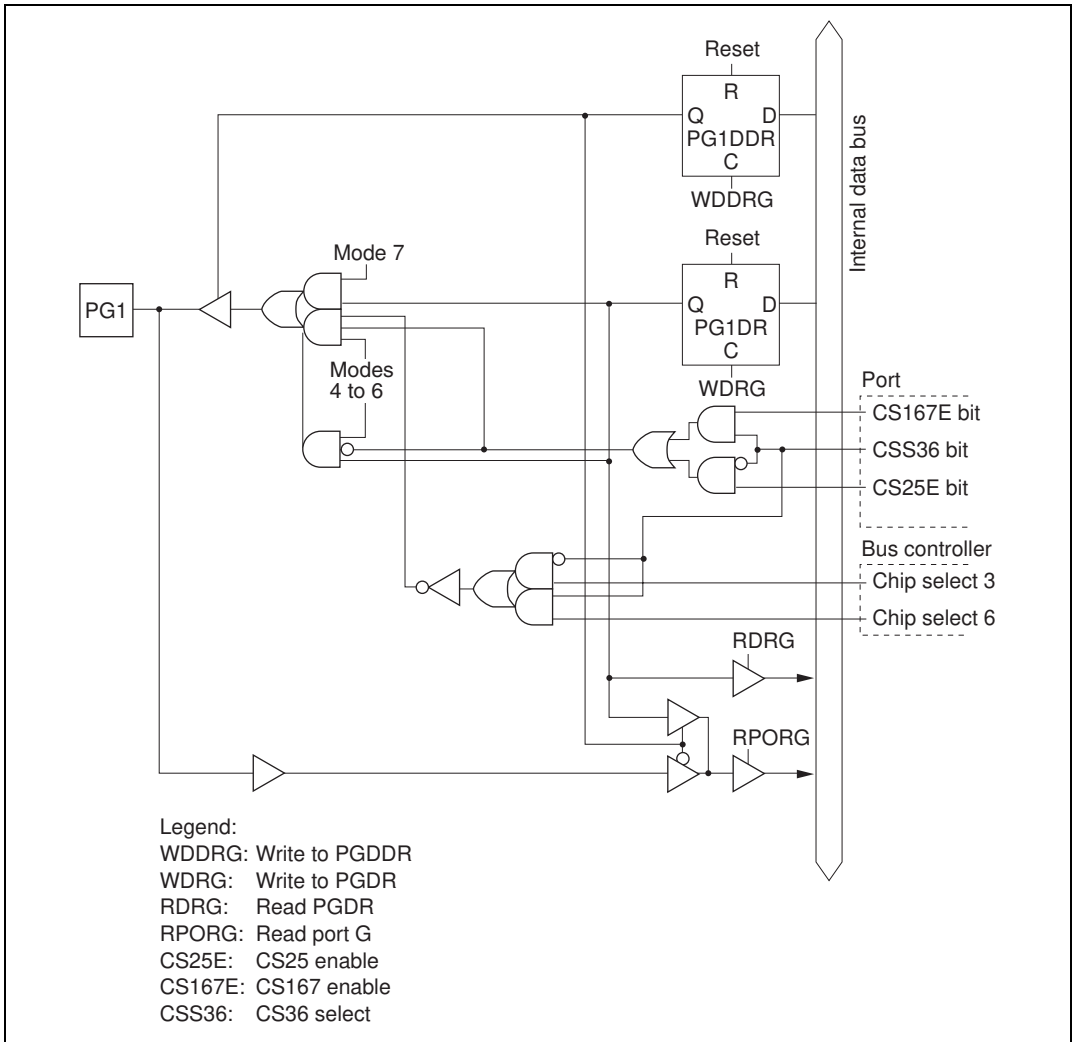

Figure C.11(b) Port G Block Diagram (Pin PG1)

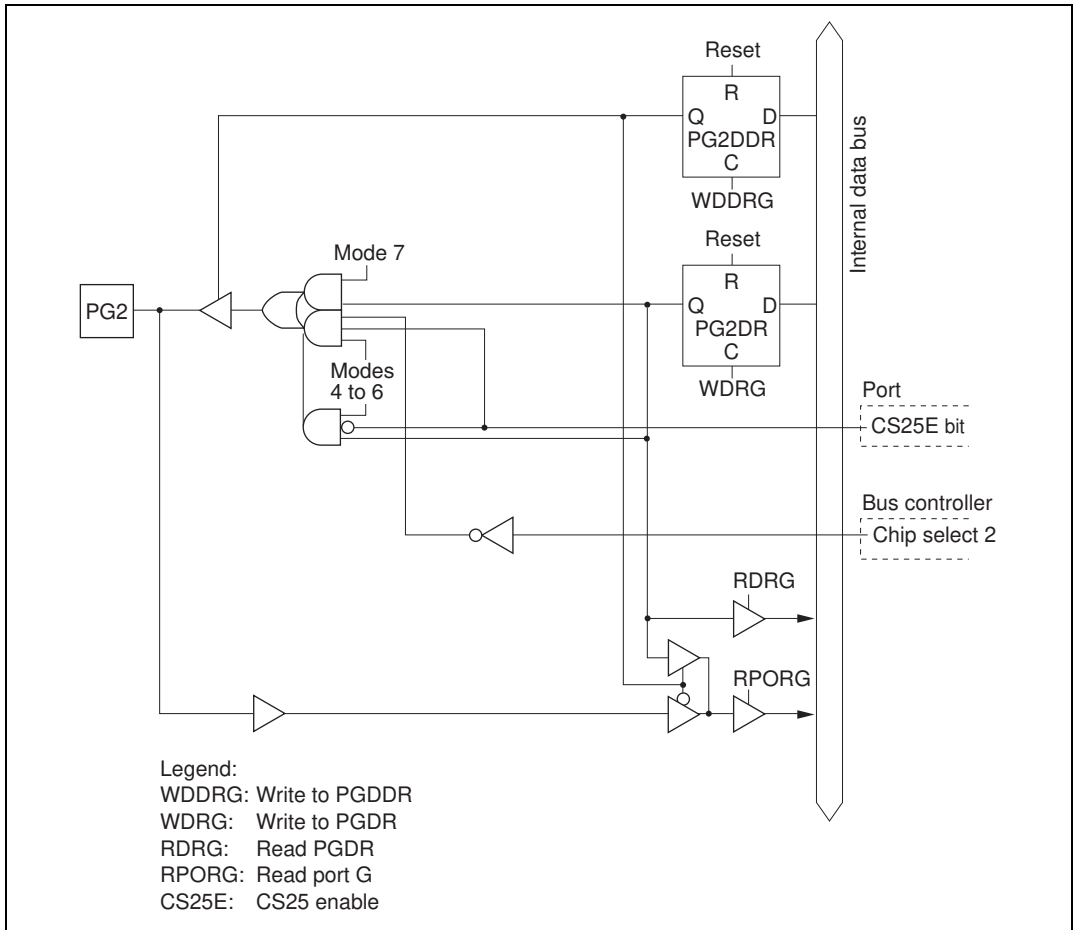

Figure C.11(c) Port G Block Diagram (Pin PG2)

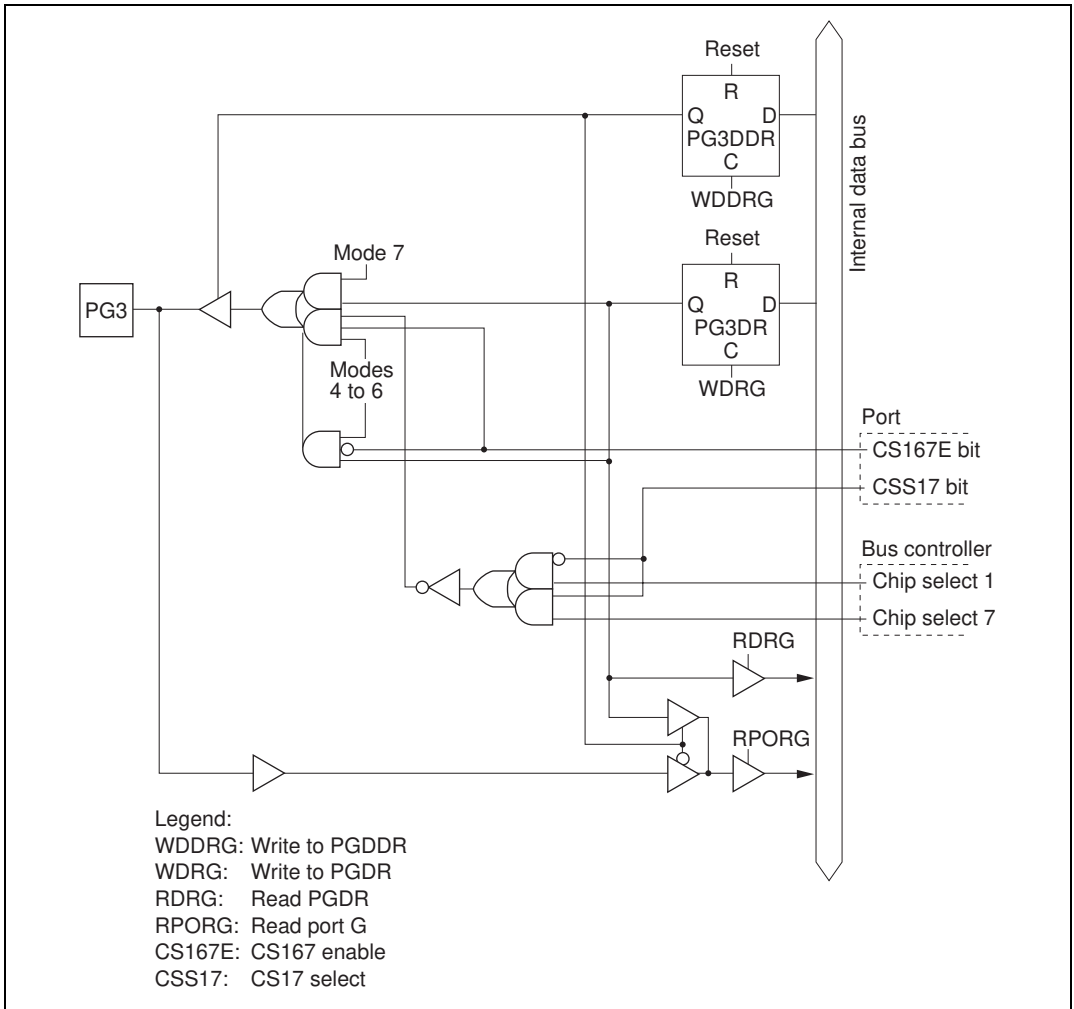

Figure C.11(d) Port G Block Diagram (Pin PG3)

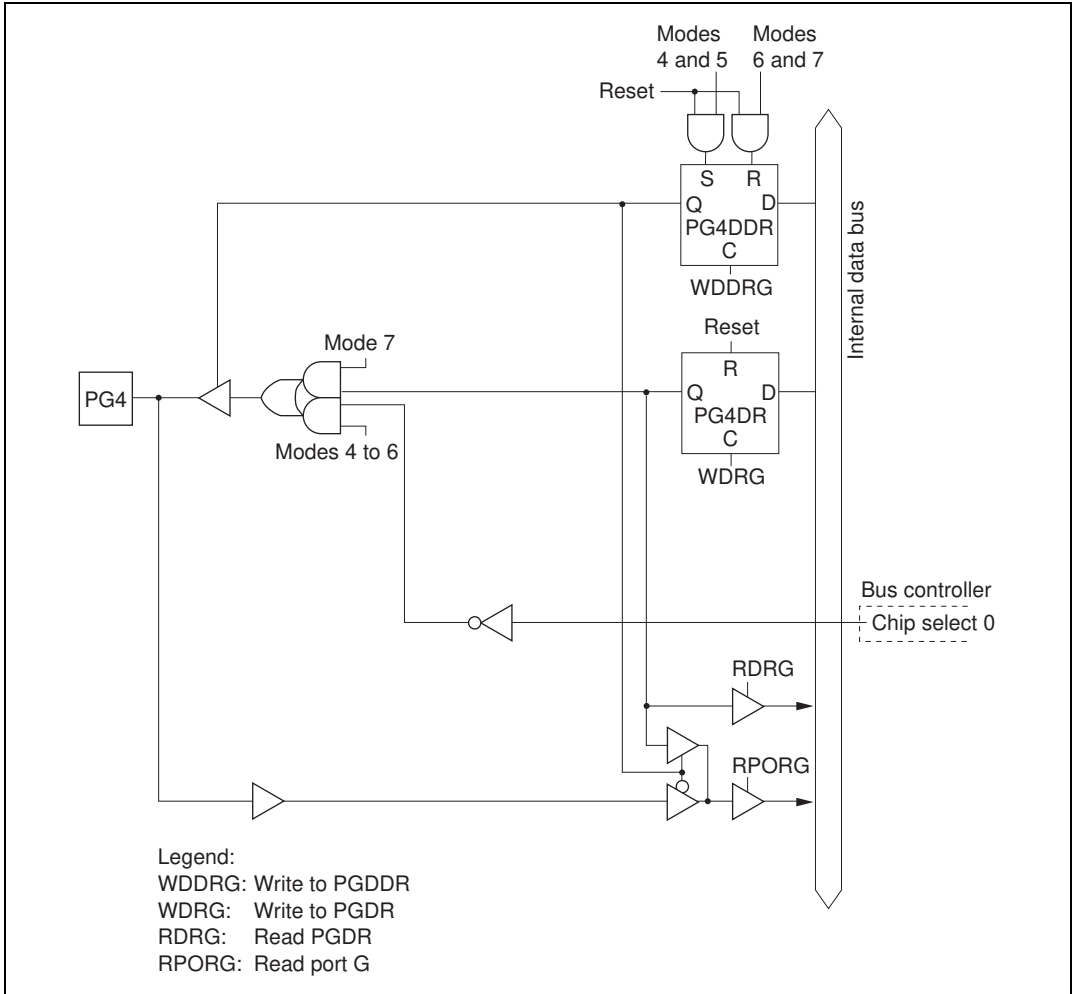

Figure C.11(e) Port G Block Diagram (Pin PG4)

Appendix D Pin States

D.1 Port States in Each Mode

Table D.1 I/O Port States in Each Processing State

Port Name Pin Name	MCU Operating Mode	Reset	Hardware Standby Mode	Software Standby Mode	Bus-Released State	Program Execution State Sleep Mode
P17/TIOCB2/ TCLKD	4 to 7	T	T	kept	kept	I/O port
P16/TIOCA2						
P15/TIOCB1/ TCLKC						
P14/TIOCA1						
P13/TIOGD0/ TCLKB/A23	4 to 6	T	T	[AnE = 0] kept	[AnE = 0] kept	[AnE = 0] I/O port
P12/TIOCC0/T CLKA/A22				[AnE · $\overline{\text{DDR}}$ = 1] kept	[AnE · $\overline{\text{DDR}}$ = 1] kept	[AnE · $\overline{\text{DDR}}$ = 1] I/O port
P11/TIOCB0/ A21				[AnE · DDR · $\overline{\text{OPE}}$ = 1] T	[AnE · DDR = 1] T	[AnE · DDR = 1] Address output
P10/TIOCA0/ A20				[AnE · DDR · OPE = 1] kept		
	7	T	T	kept	kept	I/O port
Port 2	4 to 7	T	T	kept	kept	I/O port
Port 3	4 to 7	T	T	kept	kept	I/O port
P47/DA1	4 to 7	T	T	[DAOE1 = 1] kept [DAOE1 = 0] T	kept	I/O port
P46/DA0	4 to 7	T	T	[DAOE0 = 1] kept [DAOE0 = 0] T	kept	I/O port
P45 to P40	4 to 7	T	T	T	T	Input port

Port Name Pin Name	MCU Operating Mode	Reset	Hardware Standby Mode	Software Standby Mode	Bus-Released State	Program Execution State Sleep Mode
PA3/A19 PA2/A18 PA1/A17 PA0/A16	4, 5	L	T	[OPE = 0] T [OPE = 1] kept	T	Address output
	6	T	T	[DDR · OPE = 0] T [DDR · OPE = 1] kept	T	[DDR = 0] Input port [DDR = 1] Address output
	7	T	T	kept	kept	I/O port
Port B	4, 5	L	T	[OPE = 0] T [OPE = 1] kept	T	Address output
	6	T	T	[DDR · OPE = 0] T [DDR · OPE = 1] kept	T	[DDR = 0] Input port [DDR = 1] Address output
	7	T	T	kept	kept	I/O port
Port C	4, 5	L	T	[OPE = 0] T [OPE = 1] kept	T	Address output
	6	T	T	[DDR · OPE = 0] T [DDR · OPE = 1] kept	T	[DDR = 0] Input port [DDR = 1] Address output
	7	T	T	kept	kept	I/O port
Port D	4 to 6	T	T	T	T	Data bus
	7	T	T	kept	kept	I/O port
Port E	4 to 8-bit 6 bus	T	T	kept	kept	I/O port
	16-bit bus	T	T	T	T	Data bus
	7	T	T	kept	kept	I/O port

Port Name Pin Name	MCU Operating Mode	Reset	Hardware Standby Mode	Software Standby Mode	Bus-Released State	Program Execution State Sleep Mode
PF7 / ϕ	4 to 6	Clock output	T	[DDR = 0] Input port	[DDR = 0] Input port	[DDR = 0] Input port
				[DDR = 1] H	[DDR = 1] Clock output	[DDR = 1] Clock output
	7	T	T	[DDR = 0] Input port	[DDR = 0] Input port	[DDR = 0] Input port
				[DDR = 1] H	[DDR = 1] Clock output	[DDR = 1] Clock output
PF6/AS	4 to 6	H	T	[ASOD = 1] kept	[ASOD = 1] kept	[ASOD = 1] I/O port
				$[\overline{\text{ASOD}} \cdot \overline{\text{OPE}} = 1]$ T	[ASOD = 0] T	$[\text{ASOD} = 0]$ AS
	7	T	T	kept	kept	I/O port
PF5/ $\overline{\text{RD}}$ PF4/ $\overline{\text{HWR}}$	4 to 6	H	T	[OPE = 0] T	T	$\overline{\text{RD}}$, $\overline{\text{HWR}}$
				[OPE = 1] H		
	7	T	T	kept	kept	I/O port
PF3/ $\overline{\text{LWR}}$ / $\overline{\text{IRQ3}}$	4 to 6	H	T	[LWROD = 1] kept	[LWROD = 1] kept	[LWROD = 1] I/O port
				$[\overline{\text{LWROD}} \cdot \overline{\text{OPE}} = 1]$ T	[LWROD = 0] T	$[\overline{\text{LWROD}} = 0]$ LWR
	7	T	T	kept	kept	I/O port
PF2/ $\overline{\text{WAIT}}$ / $\overline{\text{IRQ2}}$ / BREQO	4 to 6	T	T	[BREQOE + WAITE = 0] kept	[BREQOE + WAITE = 0] kept	[BREQOE + WAITE = 0] I/O port
				[BREQOE = 1] kept	[BREQOE = 1] BREQO	[BREQOE = 1] BREQO
				[BREQOE = 0] And $[\text{WAITE} \cdot \overline{\text{DDR}} = 1]$ T	[BREQOE = 0] And $[\text{WAITE} \cdot \overline{\text{DDR}} = 1]$ T	[BREQOE = 0] And $[\text{WAITE} \cdot \overline{\text{DDR}} = 1]$ WAIT
	7	T	T	kept	kept	I/O port

Port Name Pin Name	MCU Operating Mode	Reset	Hardware Standby Mode	Software Standby Mode	Bus-Released State	Program Execution State Sleep Mode
PF1/ $\overline{\text{BACK}}$ / $\overline{\text{IRQ1/CS5}}$	4 to 6	T	T	[BRLE + CS25E · PF1CS5S = 0] kept $\overline{\text{[BRLE]}} \cdot \text{DDR} \cdot$ CS25E · PF1CS5S = 1] And [OPE = 0] T $\overline{\text{[BRLE]}} \cdot \text{DDR} \cdot$ CS25E · PF1CS5S = 1] And [OPE = 1] H $\overline{\text{[BRLE]}} = 1]$ $\overline{\text{BACK}}$	L	[BRLE + CS25E · PF1CS5S = 0] I/O port $\overline{\text{[BRLE]}} \cdot \text{DDR} \cdot$ CS25E · PF1CS5S = 1] $\overline{\text{CS5}}$ $\overline{\text{[BRLE]}} = 1]$ $\overline{\text{BACK}}$
	7	T	T	kept	kept	I/O port
PF0/ $\overline{\text{BREQ}}$ / $\overline{\text{IRQ0/CS4}}$	4 to 6	T	T	[BRLE + CS25E · PF0CS4S = 0] kept $\overline{\text{[BRLE]}} \cdot \text{DDR} \cdot$ CS25E · PF0CS4S = 1] And [OPE = 0] T $\overline{\text{[BRLE]}} \cdot \text{DDR} \cdot$ CS25E · PF0CS4S = 1] And [OPE = 1] H $\overline{\text{[BRLE]}} = 1]$ T	T	[BRLE + CS25E · PF0CS4S = 0] I/O port $\overline{\text{[BRLE]}} \cdot \text{DDR} \cdot$ CS25E · PF0CS4S = 1] CS4 $\overline{\text{[BRLE]}} = 1]$ $\overline{\text{BREQ}}$
	7	T	T	kept	kept	I/O port

Appendix D Pin States

Port Name Pin Name	MCU Operating Mode	Reset	Hardware Standby Mode	Software Standby Mode	Bus-Released State	Program Execution State Sleep Mode
PG4/ $\overline{CS0}$	4, 5	H	T	[DDR · OPE = 0] T	T	[DDR = 0] Input port
	6	T		[DDR · OPE = 1] H		[DDR = 1] $\overline{CS0}$
	7	T	T	kept	kept	I/O port
PG3/ $\overline{CS1}$ / $\overline{CS7}$	4 to 6	T	T	[CS167E = 0] kept	[CS167E = 0] kept	[CS167E = 0] I/O port
				[CS167E · \overline{DDR} = 1] T	[CS167E = 1] T	[CS167E · \overline{DDR} = 1] Input port
				[CS167E · DDR · OPE = 1] T		[CS167E · CSS17 · DDR = 1] $\overline{CS1}$
				[CS167E · DDR · OPE = 1] H		[CS167E · CSS17 · DDR = 1] $\overline{CS7}$
	7	T	T	kept	kept	I/O port
PG2/ $\overline{CS2}$	4 to 6	T	T	[CS25E = 0] kept	[CS25E = 0] kept	[CS25E = 0] I/O port
				[CS25E · \overline{DDR} = 1] T	[CS25E = 1] T	[CS25E · \overline{DDR} = 1] Input port
				[CS25E · DDR · OPE = 1] T		[CS25E · DDR = 1] $\overline{CS2}$
				[CS25E · DDR · OPE = 1] H		
	7	T	T	kept	kept	I/O port

Port Name Pin Name	MCU Operating Mode	Reset	Hardware Standby Mode	Software Standby Mode	Bus-Released State	Program Execution State Sleep Mode
PG1/ $\overline{\text{CS3}}$ / $\overline{\text{CS6}}$ / $\overline{\text{IRQ7}}$	4 to 6	T	T	$[\overline{\text{CSS36}} \cdot \text{CS25E} +$ $\text{CSS36} \cdot \text{CS167E}$ $= 0]$ kept $[\overline{\text{CSS36}} \cdot \text{CS25E} \cdot$ $\overline{\text{DDR}} = 1]$ T $[\text{CSS36} \cdot \text{CS167E} \cdot$ $\overline{\text{DDR}} = 1]$ T $[\overline{\text{CSS36}} \cdot \text{CS25E} \cdot$ $\overline{\text{DDR}} \cdot \text{OPE} = 1]$ T $[\text{CSS36} \cdot \text{CS167E} \cdot$ $\overline{\text{DDR}} \cdot \text{OPE} = 1]$ T $[\overline{\text{CSS36}} \cdot \text{CS25E} \cdot$ $\overline{\text{DDR}} \cdot \text{OPE} = 1]$ H $[\text{CSS36} \cdot \text{CS167E} \cdot$ $\overline{\text{DDR}} \cdot \text{OPE} = 1]$ H	$[\overline{\text{CSS36}} \cdot \text{CS25E} +$ $\text{CSS36} \cdot \text{CS167E}$ $= 0]$ kept $[\overline{\text{CSS36}} \cdot \text{CS25E} +$ $\text{CSS36} \cdot \text{CS167E}$ $= 1]$ T $[\overline{\text{CSS36}} \cdot \text{CS25E} \cdot$ $\overline{\text{DDR}} = 1]$ Input port $[\text{CSS36} \cdot \text{CS167E} \cdot$ $\overline{\text{DDR}} = 1]$ Input port $[\overline{\text{CSS36}} \cdot \text{CS25E} \cdot$ $\overline{\text{DDR}} = 1]$ CS3 $[\text{CSS36} \cdot \text{CS167E} \cdot$ $\overline{\text{DDR}} = 1]$ $\overline{\text{CS6}}$	
	7	T	T	kept	kept	I/O port
PG0/ $\overline{\text{ADTRG}}$ / $\overline{\text{IRQ6}}$	4 to 7	T	T	kept	kept	I/O port
$\overline{\text{WDTOVF}}^{*1}$	4 to 7	H	H	H	H	H ^{*2}

Legend:

H:	High level
L:	Low level
T:	High impedance
kept:	Input port becomes high-impedance, output port retains state
DDR:	Data direction register
OPE:	Output port enable
WAITE:	Wait input enable
BRLE:	Bus release enable
BREQOE:	BREQO pin enable
AnE:	Address n enable (n = 23 to 20)
ASOD:	AS output disable
CS167E:	CS167 enable
CS25E:	CS25 enable

CSS36: CS36 select
CSS17: CS17 select
PF1CS5S: Port F1 chip select 5 select
PF0CS4S: Port F0 chip select 4 select
LWROD: LWR output disable
DAOEn: D/A output enable n (n = 0, 1)

- Notes: 1. The $\overline{\text{WDTOVF}}$ pin function is not usable on the F-ZTAT version.
2. A low level is output if a WDT overflow occurs while $\text{WT}/\overline{\text{IT}}$ is set to 1.

Appendix E Product Lineup

Table E.1 H8S/2319 Group Product Lineup

Product Type	Part No.	Marking	Package (Package Code)
H8S/2319	Mask ROM version	HD6432319	HD6432319TE 100-pin TQFP (TFP-100B)
			HD6432319F 100-pin QFP (FP-100A)
	F-ZTAT version	HD64F2319	HD64F2319VTE 100-pin TQFP (TFP-100B)
			HD64F2319VF 100-pin QFP (FP-100A)
		HD64F2319E ^{*1}	HD64F2319EVTE 100-pin TQFP (TFP-100B)
			HD64F2319EVF 100-pin QFP (FP-100A)
		HD64F2319C	HD64F2319CVTE 100-pin TQFP (TFP-100B)
			HD64F2319CVF 100-pin QFP (FP-100A)
	HD64F2319CLP 113-pin LGA (TLP-113V)		
	H8S/2318	Mask ROM version	HD6432318
HD6432318F 100-pin QFP (FP-100A)			
F-ZTAT version		HD64F2318	HD64F2318VTE 100-pin TQFP (TFP-100B)
			HD64F2318VTF 100-pin TQFP (TFP-100G)
		HD64F2318VF 100-pin QFP (FP-100A)	
H8S/2317(S) ^{*2}	Mask ROM version	HD6432317S	HD64F2317STE 100-pin TQFP (TFP-100B)
			HD6432317STF 100-pin TQFP (TFP-100G)
			HD64F2317SF 100-pin QFP (FP-100A)
			HD6432317SLP 113-pin LGA (TLP-113V)
	F-ZTAT version	HD64F2317	HD64F2317VTE 100-pin TQFP (TFP-100B)
			HD64F2317VTF 100-pin TQFP (TFP-100G)
			HD64F2317VF 100-pin QFP (FP-100A)
H8S/2316S	Mask ROM version	HD6432316S	HD6432316TE 100-pin TQFP (TFP-100B)
			HD6432316STF 100-pin TQFP (TFP-100G)
			HD6432316F 100-pin QFP (FP-100A)
			HD6432316SLP 113-pin LGA (TLP-113V)
H8S/2315	Mask ROM version	HD6432315	HD6432315VTE 100-pin TQFP (TFP-100B)
			HD6432315VE 100-pin QFP (FP-100A)
	F-ZTAT version	HD64F2315	HD64F2315VTE 100-pin TQFP (TFP-100B)
			HD64F2315VF 100-pin QFP (FP-100A)

Product Type		Part No.	Marking	Package (Package Code)
H8S/2314	Mask ROM version	HD6432314	HD6432314VTE	100-pin TQFP (TFP-100B)
			HD6432314VE	100-pin QFP (FP-100A)
	F-ZTAT version	HD64F2314	HD64F2314VTE	100-pin TQFP (TFP-100B)
			HD64F2314VF	100-pin QFP (FP-100A)
H8S/2312S	ROMless version	HD6412312S	HD6412312SVTE	100-pin TQFP (TFP-100B)
			HD6412312SVF	100-pin QFP (FP-100A)

- Notes: 1. The on-chip debug function can be used with the E10A emulator (E10A compatible version).
2. H8S/2317S in mask ROM version.

Appendix F Package Dimensions

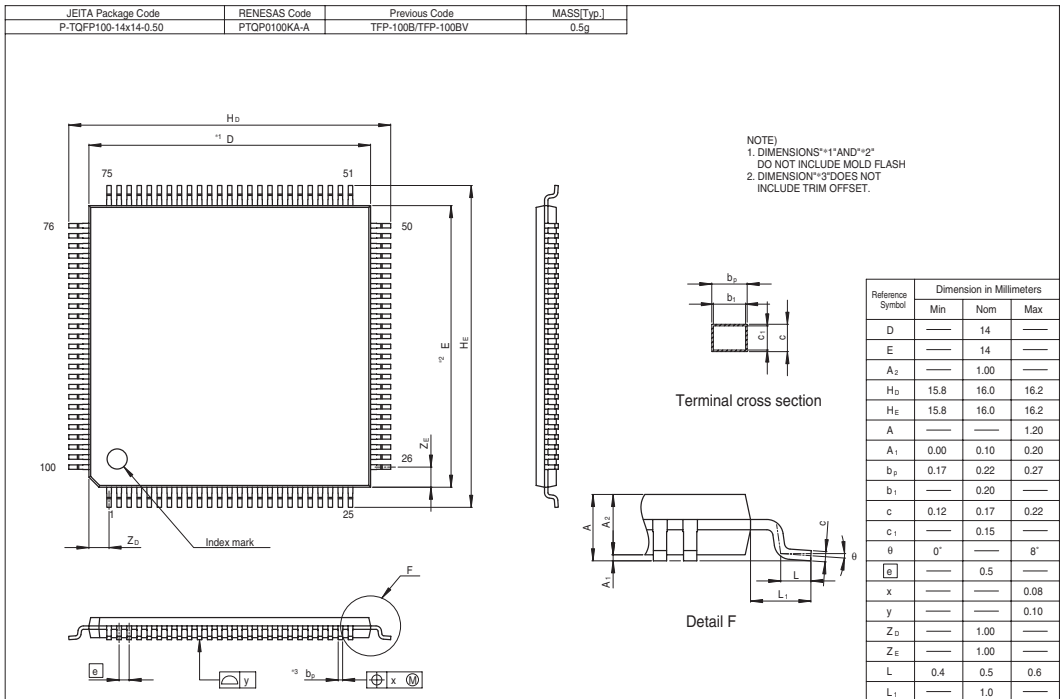

Figure F.1 TFP-100B Package Dimensions

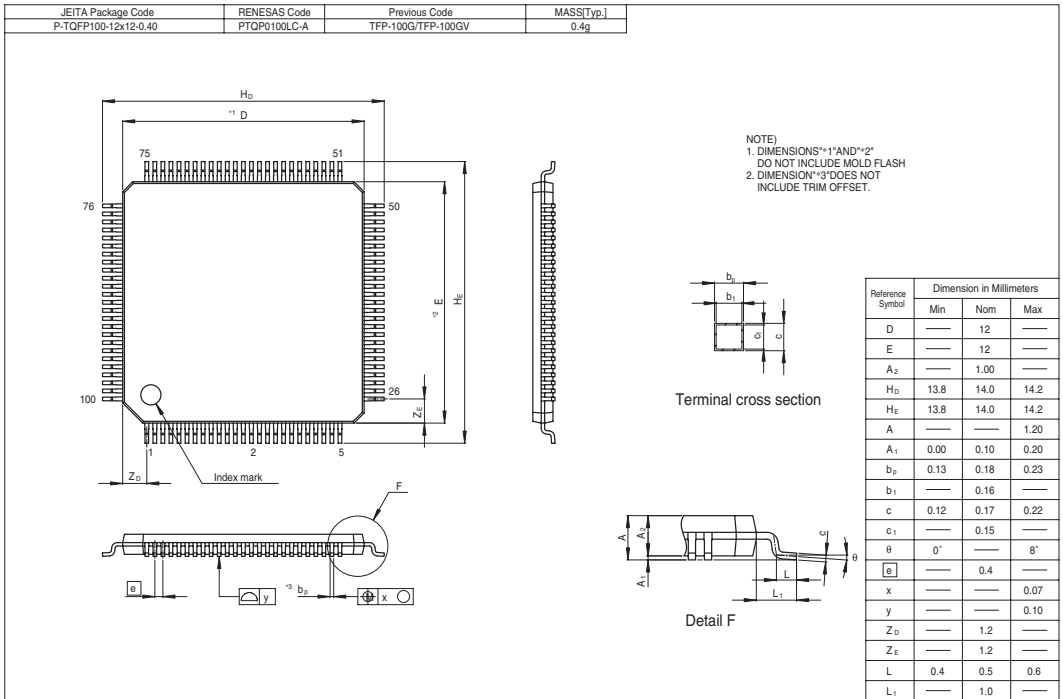

Figure F.2 TFP-100G Package Dimensions

JEITA Package Code	RENESAS Code	Previous Code	MASS[Typ.]
P-QFP100-14x20-0.65	PRQP0100JE-B	FP-100A/FP-100AV	1.7g

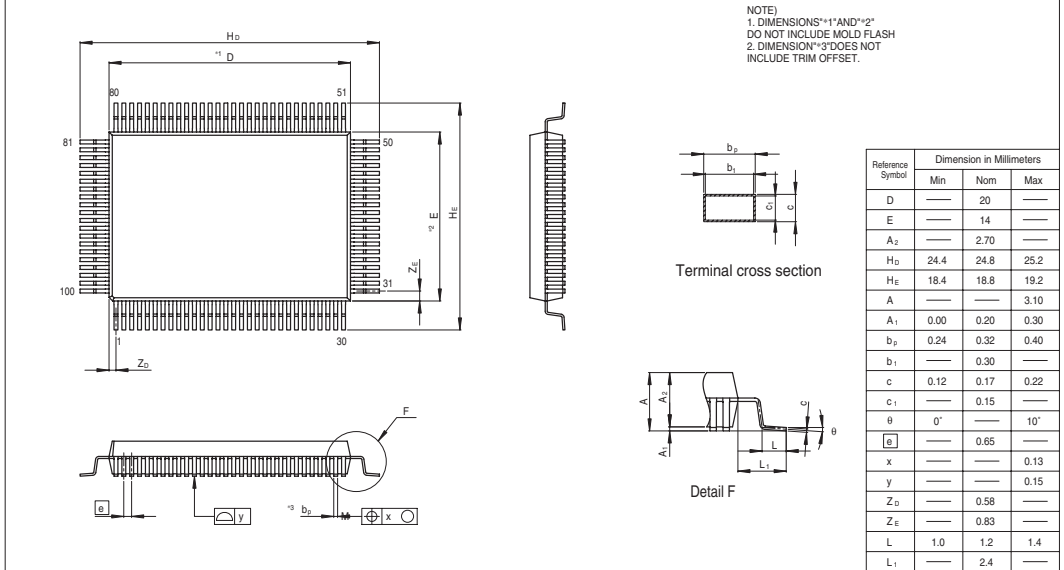

Figure F.3 FP-100A Package Dimensions

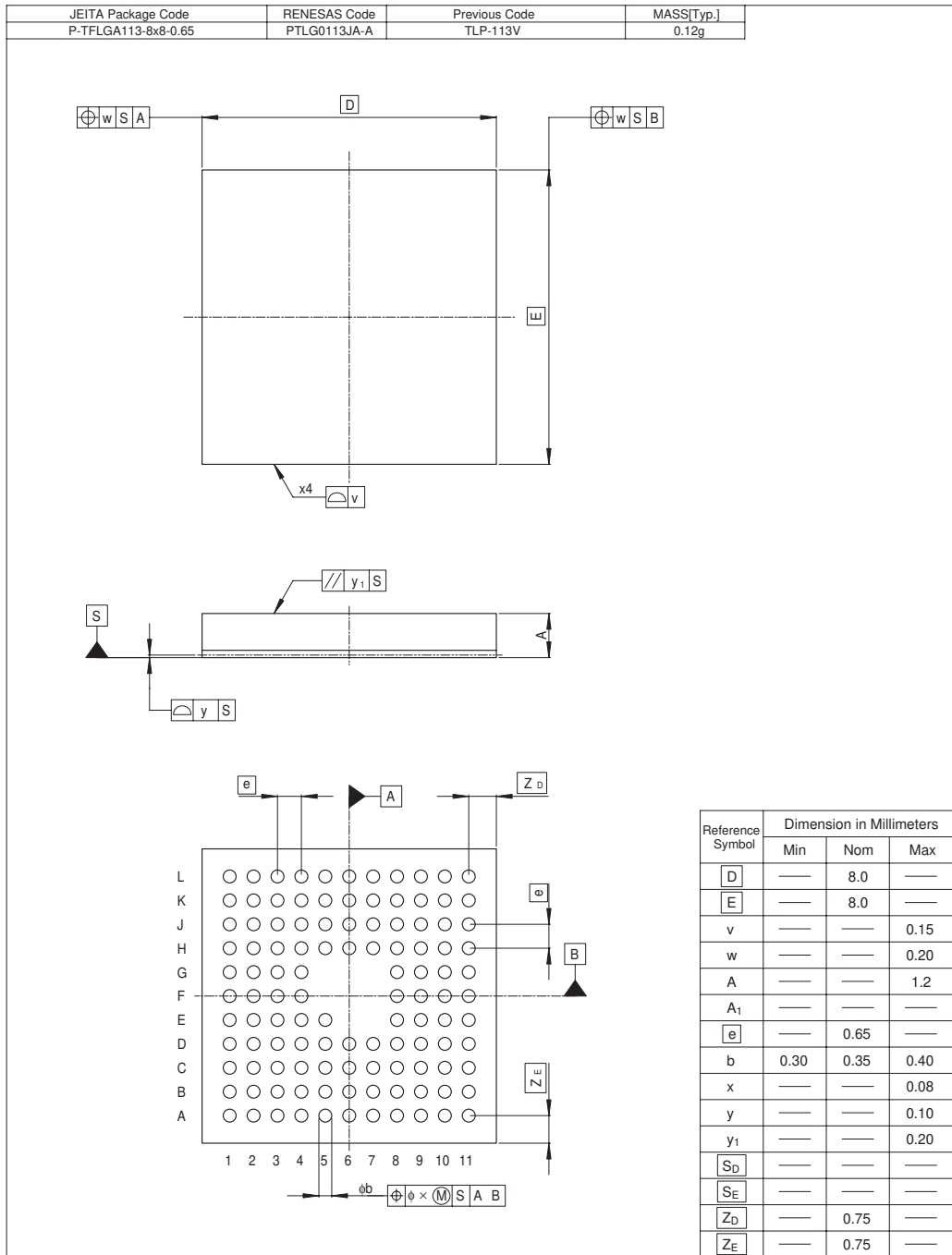

Figure F.4 TLP-113V Package Dimensions

**Renesas 16-Bit Single-Chip Microcomputer
Hardware Manual
H8S/2319 Group**

Publication Date: 1st Edition, March 1999
Rev.7.00, February 14, 2007
Published by: Sales Strategic Planning Div.
Renesas Technology Corp.
Edited by: Customer Support Department
Global Strategic Communication Div.
Renesas Solutions Corp.

Renesas Technology Corp. Sales Strategic Planning Div. Nippon Bldg., 2-6-2, Ohte-machi, Chiyoda-ku, Tokyo 100-0004, Japan



RENESAS SALES OFFICES

<http://www.renesas.com>

Refer to "<http://www.renesas.com/en/network>" for the latest and detailed information.

Renesas Technology America, Inc.

450 Holger Way, San Jose, CA 95134-1368, U.S.A
Tel: <1> (408) 382-7500, Fax: <1> (408) 382-7501

Renesas Technology Europe Limited

Dukes Meadow, Millboard Road, Bourne End, Buckinghamshire, SL8 5FH, U.K.
Tel: <44> (1628) 585-100, Fax: <44> (1628) 585-900

Renesas Technology (Shanghai) Co., Ltd.

Unit 204, 205, AZIAcenter, No.1233 Lujiazui Ring Rd, Pudong District, Shanghai, China 200120
Tel: <86> (21) 5877-1818, Fax: <86> (21) 6887-7898

Renesas Technology Hong Kong Ltd.

7th Floor, North Tower, World Finance Centre, Harbour City, 1 Canton Road, Tsimshatsui, Kowloon, Hong Kong
Tel: <852> 2265-6688, Fax: <852> 2730-6071

Renesas Technology Taiwan Co., Ltd.

10th Floor, No.99, Fushing North Road, Taipei, Taiwan
Tel: <886> (2) 2715-2888, Fax: <886> (2) 2713-2999

Renesas Technology Singapore Pte. Ltd.

1 Harbour Front Avenue, #06-10, Keppel Bay Tower, Singapore 098632
Tel: <65> 6213-0200, Fax: <65> 6278-8001

Renesas Technology Korea Co., Ltd.

Kukje Center Bldg. 18th Fl., 191, 2-ka, Hangang-ro, Yongsan-ku, Seoul 140-702, Korea
Tel: <82> (2) 796-3115, Fax: <82> (2) 796-2145

Renesas Technology Malaysia Sdn. Bhd

Unit 906, Block B, Menara Amcorp, Amcorp Trade Centre, No.18, Jalan Persiaran Barat, 46050 Petaling Jaya, Selangor Darul Ehsan, Malaysia
Tel: <603> 7955-9390, Fax: <603> 7955-9510

H8S/2319 Group Hardware Manual



Renesas Electronics Corporation

1753, Shimonumabe, Nakahara-ku, Kawasaki-shi, Kanagawa 211-8668 Japan

REJ09B0089-0700