

SN54HC646, SN74HC646 OCTAL BUS TRANSCEIVERS AND REGISTERS WITH 3-STATE OUTPUTS

SCLS150C – DECEMBER 1982 – REVISED MARCH 2003

- Wide Operating Voltage Range of 2 V to 6 V
- High-Current 3-State Outputs Can Drive Up To 15 LSTTL Loads
- Low Power Consumption, 80- μ A Max I_{CC}
- Typical $t_{pd} = 11$ ns
- ± 6 -mA Output Drive at 5 V
- Low Input Current of 1 μ A Max
- Independent Registers for A and B Buses
- Multiplexed Real-Time and Stored Data
- True Data Paths

SN54HC646 . . . JT OR W PACKAGE
SN74HC646 . . . DW OR NT PACKAGE
(TOP VIEW)

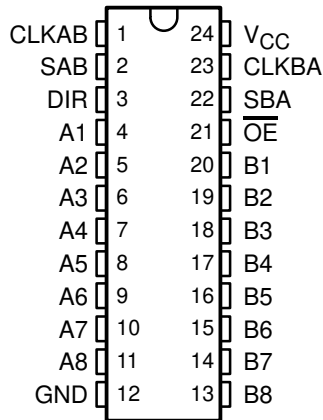

SN54HC646 . . . FK PACKAGE
(TOP VIEW)

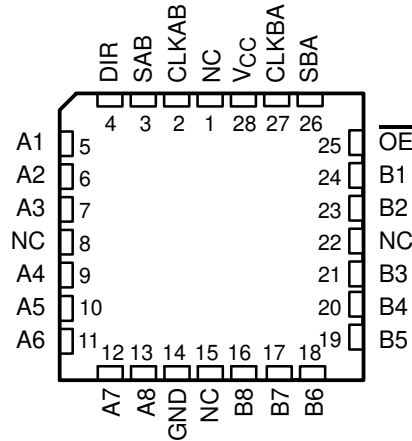

NC – No internal connection

description/ordering information

The 'HC646 devices consist of bus-transceiver circuits with 3-state outputs, D-type flip-flops, and control circuitry arranged for multiplexed transmission of data directly from the input bus or from the internal registers. Data on the A or B bus is clocked into the registers on the low-to-high transition of the appropriate clock (CLKAB or CLKBA) input. Figure 1 illustrates the four fundamental bus-management functions that can be performed with the 'HC646 devices.

Output-enable (\overline{OE}) and direction-control (DIR) inputs control the transceiver functions. In the transceiver mode, data present at the high-impedance port may be stored in either or both registers.

The select-control (SAB and SBA) inputs can multiplex stored and real-time (transparent mode) data. DIR determines which bus receives data when \overline{OE} is active (low). In the isolation mode (\overline{OE} high), A data may be stored in one register and/or B data may be stored in the other register.

ORDERING INFORMATION

TA	PACKAGE†		ORDERABLE PART NUMBER	TOP-SIDE MARKING
-40°C to 85°C	PDIP – NT	Tube	SN74HC646NT	HC646
	SOIC – DW	Tube	SN74HC646DW	
		Tape and reel	SN74HC646DWR	
-55°C to 125°C	CDIP – JT	Tube	SNJ54HC646JT	SNJ54HC646JT
	CFP – W	Tube	SNJ54HC646W	SNJ54HC646W
	LCCC – FK	Tube	SNJ54HC646FK	SNJ54HC646FK

† Package drawings, standard packing quantities, thermal data, symbolization, and PCB design guidelines are available at www.ti.com/sc/package.



Please be aware that an important notice concerning availability, standard warranty, and use in critical applications of Texas Instruments semiconductor products and disclaimers thereto appears at the end of this data sheet.

UNLESS OTHERWISE NOTED this document contains PRODUCTION DATA information current as of publication date. Products conform to specifications per the terms of Texas Instruments standard warranty. Production processing does not necessarily include testing of all parameters.

 **TEXAS
INSTRUMENTS**

POST OFFICE BOX 655303 • DALLAS, TEXAS 75265

Copyright © 2003, Texas Instruments Incorporated

SN54HC646, SN74HC646 OCTAL BUS TRANSCEIVERS AND REGISTERS WITH 3-STATE OUTPUTS

SCLS150C – DECEMBER 1982 – REVISED MARCH 2003

description/ordering information (continued)

To ensure the high-impedance state during power up or power down, \overline{OE} should be tied to V_{CC} through a pullup resistor; the minimum value of the resistor is determined by the current-sinking capability of the driver.

When an output function is disabled, the input function is still enabled and can be used to store data. Only one of the two buses, A or B, may be driven at a time.

FUNCTION TABLE

INPUTS						DATA I/O		OPERATION OR FUNCTION
OE	DIR	CLKAB	CLKBA	SAB	SBA	A1–A8	B1–B8	
X	X	↑	X	X	X	Input	Unspecified†	Store A, B unspecified†
X	X	X	↑	X	X	Unspecified†	Input	Store B, A unspecified†
H	X	↑	↑	X	X	Input	Input	Store A and B data
H	X	H or L	H or L	X	X	Input disabled	Input disabled	Isolation, hold storage
L	L	X	X	X	L	Output	Input	Real-time B data to A bus
L	L	X	H or L	X	H	Output	Input	Stored B data to A bus
L	H	X	X	L	X	Input	Output	Real-time A data to B bus
L	H	H or L	X	H	X	Input	Output	Stored A data to B bus

† The data-output functions can be enabled or disabled by various signals at \overline{OE} and DIR. Data-input functions always are enabled; i.e., data at the bus terminals is stored on every low-to-high transition of the clock inputs.

SN54HC646, SN74HC646 OCTAL BUS TRANSCEIVERS AND REGISTERS WITH 3-STATE OUTPUTS

SCLS150C – DECEMBER 1982 – REVISED MARCH 2003

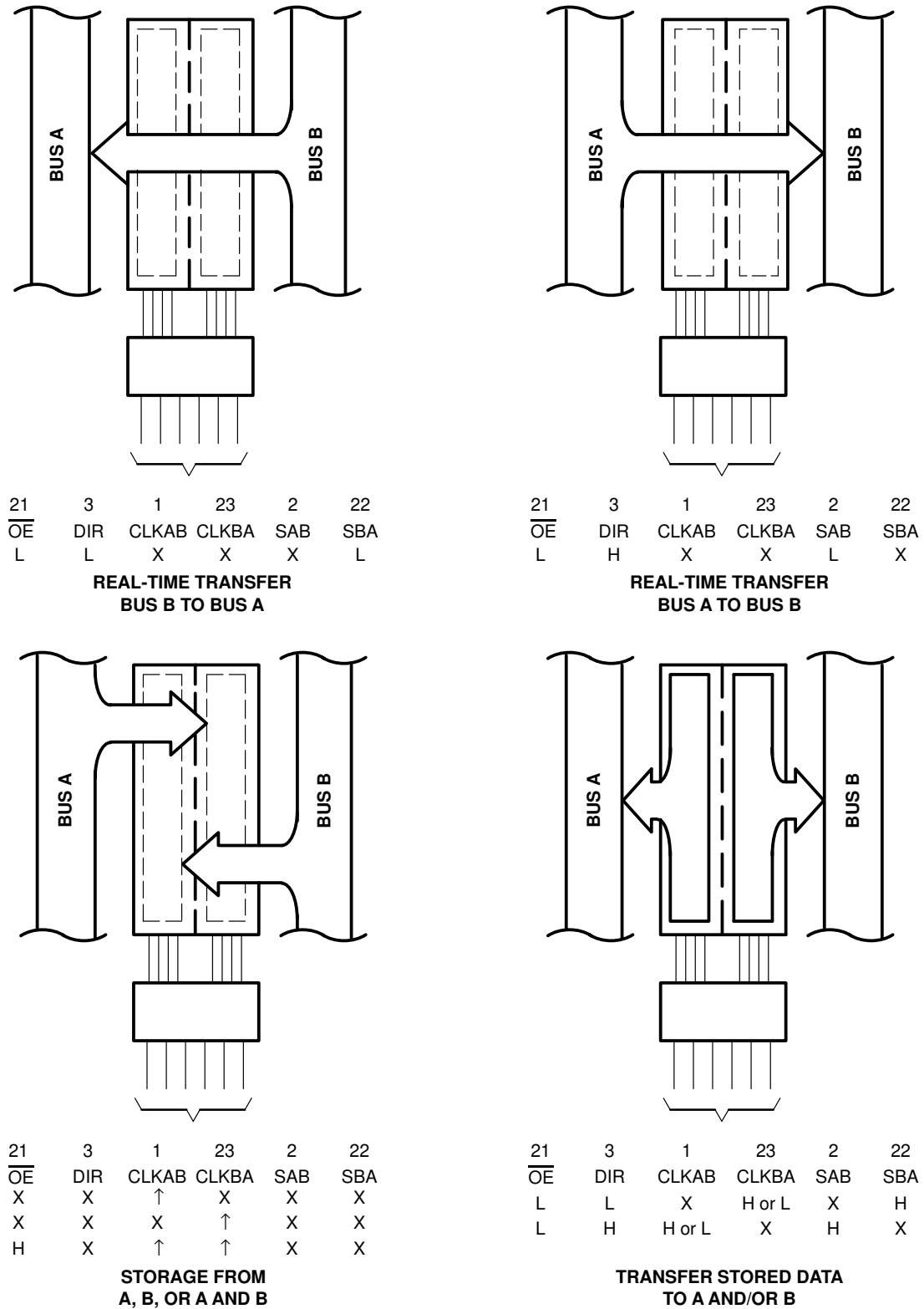

Pin numbers shown are for the DW, JT, NT, and W packages.

Figure 1. Bus-Management Functions

SN54HC646, SN74HC646 OCTAL BUS TRANSCEIVERS AND REGISTERS WITH 3-STATE OUTPUTS

SCLS150C – DECEMBER 1982 – REVISED MARCH 2003

logic diagram (positive logic)

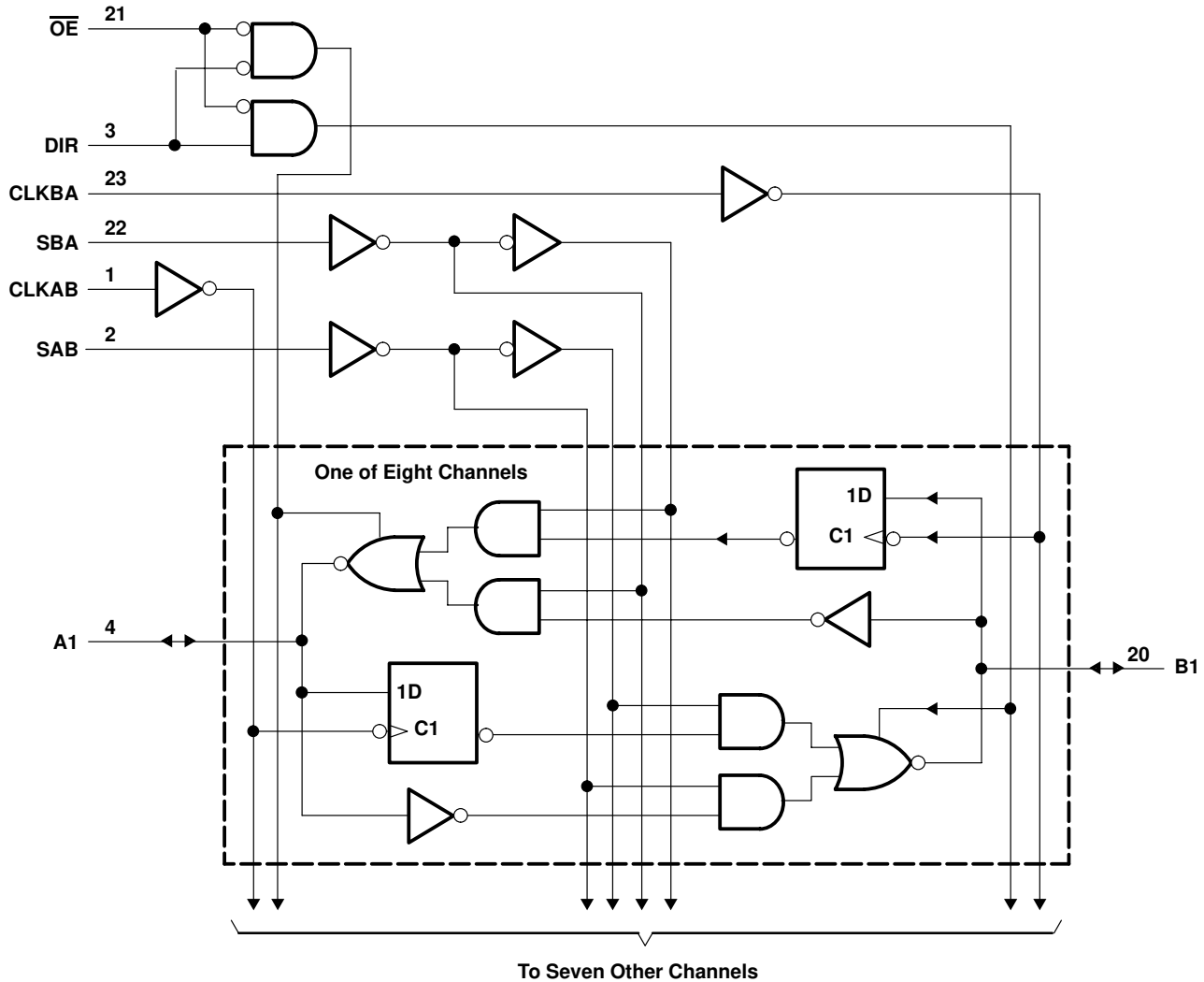

Pin numbers shown are for the DW, JT, NT, and W packages.

absolute maximum ratings over operating free-air temperature range (unless otherwise noted)†

Supply voltage range, V_{CC}	-0.5 V to 7 V
Input clamp current, I_{IK} ($V_I < 0$ or $V_I > V_{CC}$) (see Note 1)	± 20 mA
Output clamp current, I_{OK} ($V_O < 0$ or $V_O > V_{CC}$) (see Note 1)	± 20 mA
Continuous output current, I_O ($V_O = 0$ to V_{CC})	± 35 mA
Continuous current through V_{CC} or GND	± 70 mA
Package thermal impedance, θ_{JA} (see Note 2): DW package	46°C/W
(see Note 3): NT package	67°C/W
Storage temperature range, T_{stg}	-65°C to 150°C

† Stresses beyond those listed under "absolute maximum ratings" may cause permanent damage to the device. These are stress ratings only, and functional operation of the device at these or any other conditions beyond those indicated under "recommended operating conditions" is not implied. Exposure to absolute-maximum-rated conditions for extended periods may affect device reliability.

- NOTES: 1. The input and output voltage ratings may be exceeded if the input and output current ratings are observed.
 2. The package thermal impedance is calculated in accordance with JESD 51-7.
 3. The package thermal impedance is calculated in accordance with JESD 51-3.



POST OFFICE BOX 655303 • DALLAS, TEXAS 75265

SN54HC646, SN74HC646 OCTAL BUS TRANSCEIVERS AND REGISTERS WITH 3-STATE OUTPUTS

SCLS150C – DECEMBER 1982 – REVISED MARCH 2003

recommended operating conditions (see Note 4)

		SN54HC646			SN74HC646			UNIT
		MIN	NOM	MAX	MIN	NOM	MAX	
V _{CC}	Supply voltage	2	5	6	2	5	6	V
V _{IH}	High-level input voltage	V _{CC} = 2 V		1.5	1.5		V	
		V _{CC} = 4.5 V		3.15	3.15			
		V _{CC} = 6 V		4.2	4.2			
V _{IL}	Low-level input voltage	V _{CC} = 2 V			0.5	0.5	V	
		V _{CC} = 4.5 V			1.35	1.35		
		V _{CC} = 6 V			1.8	1.8		
V _I	Input voltage	0		V _{CC}	0	V _{CC}	V	
V _O	Output voltage	0		V _{CC}	0	V _{CC}	V	
t _t	Input transition (rise and fall) time	V _{CC} = 2 V			1000	1000	ns	
		V _{CC} = 4.5 V			500	500		
		V _{CC} = 6 V			400	400		
T _A	Operating free-air temperature	-55		125	-40	85	°C	

NOTE 4: All unused inputs of the device must be held at V_{CC} or GND to ensure proper device operation. Refer to the TI application report, *Implications of Slow or Floating CMOS Inputs*, literature number SCBA004.

electrical characteristics over recommended operating free-air temperature range (unless otherwise noted)

PARAMETER	TEST CONDITIONS		V _{CC}	T _A = 25°C			SN54HC646		SN74HC646		UNIT
				MIN	TYP	MAX	MIN	MAX	MIN	MAX	
V _{OH}	V _I = V _{IH} or V _{IL}	I _{OH} = -20 μA	2 V	1.9	1.998		1.9	1.9	V		
			4.5 V	4.4	4.499		4.4	4.4			
			6 V	5.9	5.999		5.9	5.9			
		I _{OH} = -6 mA	4.5 V	3.98	4.3		3.7	3.84			
		I _{OH} = -7.8 mA	6 V	5.48	5.8		5.2	5.34			
V _{OL}	V _I = V _{IH} or V _{IL}	I _{OL} = 20 μA	2 V		0.002	0.1		0.1	0.1	V	
			4.5 V		0.001	0.1		0.1	0.1		
			6 V		0.001	0.1		0.1	0.1		
		I _{OL} = 6 mA	4.5 V		0.17	0.26		0.4	0.33		
		I _{OL} = 7.8 mA	6 V		0.15	0.26		0.4	0.33		
I _I	Control inputs	V _I = V _{CC} or 0	6 V		±0.1	±100		±1000	±1000	nA	
I _{OZ}	A or B	V _O = V _{CC} or 0	6 V		±0.01	±0.5		±10	±5	μA	
I _{CC}		V _I = V _{CC} or 0, I _O = 0	6 V			8		160	80	μA	
C _i	Control inputs		2 V to 6 V		3	10		10	10	pF	

PRODUCT PREVIEW information concerns products in the formative or design phase of development. Characteristic data and other specifications are design goals. Texas Instruments reserves the right to change or discontinue these products without notice.



POST OFFICE BOX 655303 • DALLAS, TEXAS 75265

SN54HC646, SN74HC646
OCTAL BUS TRANSCEIVERS AND REGISTERS
WITH 3-STATE OUTPUTS

SCLS150C – DECEMBER 1982 – REVISED MARCH 2003

timing requirements over recommended operating free-air temperature range (unless otherwise noted)

	V _{CC}	T _A = 25°C		SN54HC646		SN74HC646		UNIT
		MIN	MAX	MIN	MAX	MIN	MAX	
f _{clock} Clock frequency	2 V		6		4.3		5.5	MHz
	4.5 V		31		22		27	
	6 V		36		25		31	
t _w Pulse duration, CLKBA or CLKAB high or low	2 V	80		115		95		ns
	4.5 V	16		23		19		
	6 V	14		20		16		
t _{su} Setup time, A before CLKAB↑ or B before CLKBA↑	2 V	100		150		125		ns
	4.5 V	20		30		25		
	6 V	17		26		21		
t _h Hold time, A after CLKAB↑ or B after CLKBA↑	2 V	5		5		5		ns
	4.5 V	5		5		5		
	6 V	5		5		5		

PRODUCT PREVIEW information concerns products in the formative or design phase of development. Characteristic data and other specifications are design goals. Texas Instruments reserves the right to change or discontinue these products without notice.



POST OFFICE BOX 655303 • DALLAS, TEXAS 75265

SN54HC646, SN74HC646 OCTAL BUS TRANSCEIVERS AND REGISTERS WITH 3-STATE OUTPUTS

SCLS150C – DECEMBER 1982 – REVISED MARCH 2003

switching characteristics over recommended operating free-air temperature range, $C_L = 50$ pF (unless otherwise noted) (see Figure 2)

PARAMETER	FROM (INPUT)	TO (OUTPUT)	V _{CC}	T _A = 25°C			SN54HC646		SN74HC646		UNIT
				MIN	TYP	MAX	MIN	MAX	MIN	MAX	
f _{max}			2 V	6	11		4.4		5.5	MHz	
			4.5 V	31	54		22		27		
			6 V	36	64		25		31		
t _{pd}	CLKBA or CLKAB	A or B	2 V		65	180		270		225	ns
			4.5 V		18	36		54		45	
			6 V		14	31		46		38	
	A or B	B or A	2 V		50	135		205		170	
			4.5 V		14	27		41		34	
			6 V		11	23		35		29	
	SBA or SAB†	A or B	2 V		70	190		285		240	
			4.5 V		20	38		57		48	
			6 V		16	32		48		41	
t _{en}	\overline{OE}	A or B	2 V		85	245		370		305	ns
			4.5 V		25	49		74		61	
			6 V		20	42		63		52	
t _{dis}	\overline{OE}	A or B	2 V		85	245		370		305	ns
			4.5 V		25	49		74		61	
			6 V		20	42		63		52	
t _{en}	DIR	A or B	2 V		80	245		370		305	ns
			4.5 V		25	49		74		61	
			6 V		20	42		63		52	
t _{dis}	DIR	A or B	2 V		80	245		370		305	ns
			4.5 V		25	49		74		61	
			6 V		20	42		63		52	
t _t		Any	2 V		28	60		90		75	ns
			4.5 V		8	12		18		15	
			6 V		6	10		15		13	

† These parameters are measured with the internal output state of the storage register opposite that of the bus input.

SN54HC646, SN74HC646 OCTAL BUS TRANSCEIVERS AND REGISTERS WITH 3-STATE OUTPUTS

SCLS150C – DECEMBER 1982 – REVISED MARCH 2003

switching characteristics over recommended operating free-air temperature range, $C_L = 150 \text{ pF}$
(unless otherwise noted) (see Figure 2)

PARAMETER	FROM (INPUT)	TO (OUTPUT)	V_{CC}	$T_A = 25^\circ\text{C}$			SN54HC646		SN74HC646		UNIT
				MIN	TYP	MAX	MIN	MAX	MIN	MAX	
t_{pd}	CLKBA or CLKAB	A or B	2 V		90	265		400		330	ns
			4.5 V		24	53		80		66	
			6 V		20	46		68		57	
	A or B	B or A	2 V		70	220		335		280	
			4.5 V		20	44		67		56	
			6 V		15	38		57		49	
	SBA or SAB†	A or B	2 V		80	275		415		345	
			4.5 V		24	55		83		69	
			6 V		20	47		70		60	
t_{en}	\overline{OE}	A or B	2 V		113	330		500		410	ns
			4.5 V		33	66		100		82	
			6 V		27	57		85		71	
	DIR	A or B	2 V		113	330		500		410	
			4.5 V		33	66		100		82	
			6 V		27	57		85		71	
t_t		Any	2 V		45	210		315		265	ns
			4.5 V		17	42		63		53	
			6 V		13	36		53		43	

† These parameters are measured with the internal output state of the storage register opposite that of the bus input.

operating characteristics, $T_A = 25^\circ\text{C}$

PARAMETER	TEST CONDITIONS	TYP	UNIT
C_{pd} Power dissipation capacitance	No load	50	pF

PRODUCT PREVIEW information concerns products in the formative or design phase of development. Characteristic data and other specifications are design goals. Texas Instruments reserves the right to change or discontinue these products without notice.



PARAMETER MEASUREMENT INFORMATION

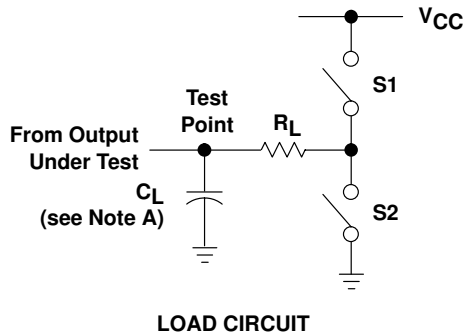

PARAMETER	R_L	C_L	S1	S2
t_{en}	1 k Ω	50 pF or 150 pF	Open	Closed
			Closed	Open
t_{dis}	1 k Ω	50 pF	Open	Closed
			Closed	Open
t_{pd} or t_t	—	50 pF or 150 pF	Open	Open

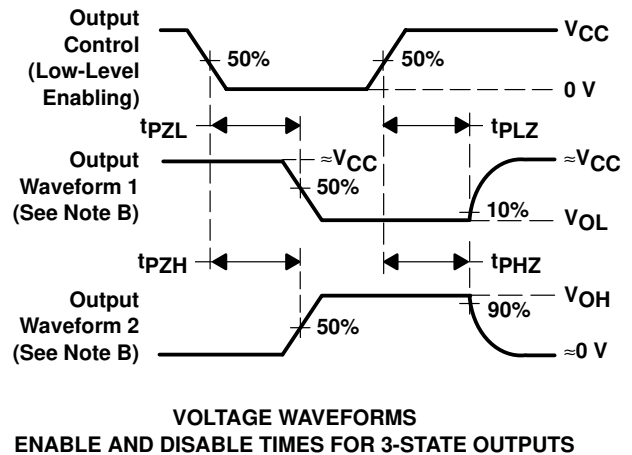
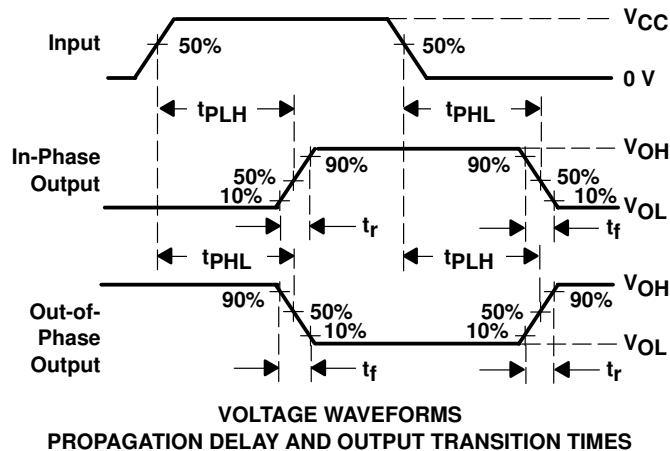
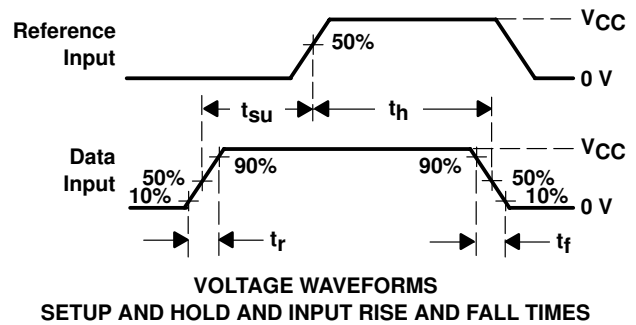
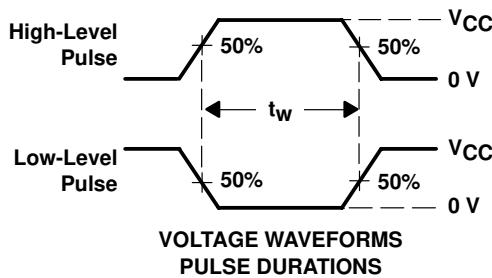

- NOTES: A. C_L includes probe and test-fixture capacitance.
 B. Waveform 1 is for an output with internal conditions such that the output is low except when disabled by the output control. Waveform 2 is for an output with internal conditions such that the output is high except when disabled by the output control.
 C. Phase relationships between waveforms were chosen arbitrarily. All input pulses are supplied by generators having the following characteristics: $PRR \leq 1$ MHz, $Z_O = 50 \Omega$, $t_r = 6$ ns, $t_f = 6$ ns.
 D. For clock inputs, f_{max} is measured when the input duty cycle is 50%.
 E. The outputs are measured one at a time with one input transition per measurement.
 F. t_{pLZ} and t_{pHZ} are the same as t_{dis} .
 G. t_{pZL} and t_{pZH} are the same as t_{en} .
 H. t_{pLH} and t_{pHL} are the same as t_{pd} .

Figure 2. Load Circuit and Voltage Waveforms

PACKAGING INFORMATION

Orderable Device	Status (1)	Package Type	Package Drawing	Pins	Package Qty	Eco Plan (2)	Lead finish/ Ball material (6)	MSL Peak Temp (3)	Op Temp (°C)	Device Marking (4/5)	Samples
SN74HC646DW	LIFEBUY	SOIC	DW	24	25	RoHS & Green	NIPDAU	Level-1-260C-UNLIM	-40 to 85	HC646	
SN74HC646DWR	ACTIVE	SOIC	DW	24	2000	RoHS & Green	NIPDAU	Level-1-260C-UNLIM	-40 to 85	HC646	Samples

(1) The marketing status values are defined as follows:

ACTIVE: Product device recommended for new designs.

LIFEBUY: TI has announced that the device will be discontinued, and a lifetime-buy period is in effect.

NRND: Not recommended for new designs. Device is in production to support existing customers, but TI does not recommend using this part in a new design.

PREVIEW: Device has been announced but is not in production. Samples may or may not be available.

OBSELETE: TI has discontinued the production of the device.

(2) **RoHS:** TI defines "RoHS" to mean semiconductor products that are compliant with the current EU RoHS requirements for all 10 RoHS substances, including the requirement that RoHS substance do not exceed 0.1% by weight in homogeneous materials. Where designed to be soldered at high temperatures, "RoHS" products are suitable for use in specified lead-free processes. TI may reference these types of products as "Pb-Free".

RoHS Exempt: TI defines "RoHS Exempt" to mean products that contain lead but are compliant with EU RoHS pursuant to a specific EU RoHS exemption.

Green: TI defines "Green" to mean the content of Chlorine (Cl) and Bromine (Br) based flame retardants meet JS709B low halogen requirements of <=1000ppm threshold. Antimony trioxide based flame retardants must also meet the <=1000ppm threshold requirement.

(3) MSL, Peak Temp. - The Moisture Sensitivity Level rating according to the JEDEC industry standard classifications, and peak solder temperature.

(4) There may be additional marking, which relates to the logo, the lot trace code information, or the environmental category on the device.

(5) Multiple Device Markings will be inside parentheses. Only one Device Marking contained in parentheses and separated by a "~" will appear on a device. If a line is indented then it is a continuation of the previous line and the two combined represent the entire Device Marking for that device.

(6) Lead finish/Ball material - Orderable Devices may have multiple material finish options. Finish options are separated by a vertical ruled line. Lead finish/Ball material values may wrap to two lines if the finish value exceeds the maximum column width.

Important Information and Disclaimer:The information provided on this page represents TI's knowledge and belief as of the date that it is provided. TI bases its knowledge and belief on information provided by third parties, and makes no representation or warranty as to the accuracy of such information. Efforts are underway to better integrate information from third parties. TI has taken and continues to take reasonable steps to provide representative and accurate information but may not have conducted destructive testing or chemical analysis on incoming materials and chemicals. TI and TI suppliers consider certain information to be proprietary, and thus CAS numbers and other limited information may not be available for release.

In no event shall TI's liability arising out of such information exceed the total purchase price of the TI part(s) at issue in this document sold by TI to Customer on an annual basis.

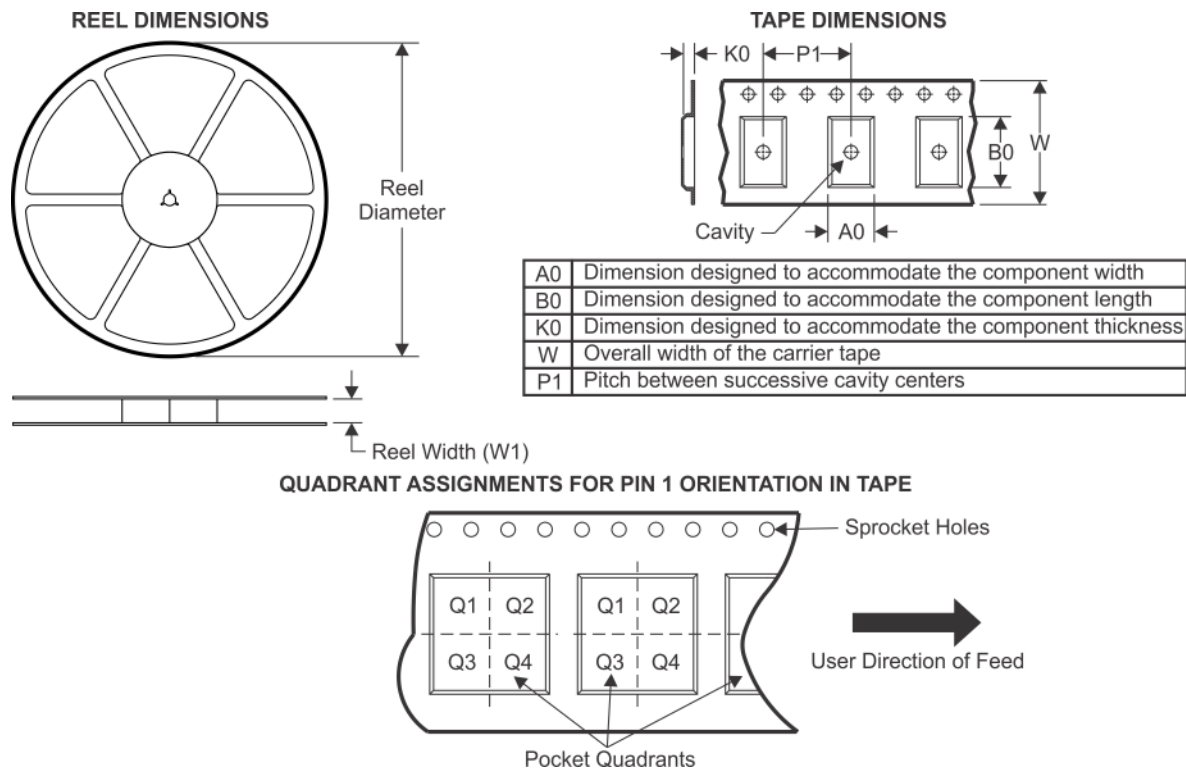
TAPE AND REEL INFORMATION

*All dimensions are nominal

Device	Package Type	Package Drawing	Pins	SPQ	Reel Diameter (mm)	Reel Width W1 (mm)	A0 (mm)	B0 (mm)	K0 (mm)	P1 (mm)	W (mm)	Pin1 Quadrant
SN74HC646DWR	SOIC	DW	24	2000	330.0	24.4	10.75	15.7	2.7	12.0	24.0	Q1

TAPE AND REEL BOX DIMENSIONS

*All dimensions are nominal

Device	Package Type	Package Drawing	Pins	SPQ	Length (mm)	Width (mm)	Height (mm)
SN74HC646DWR	SOIC	DW	24	2000	350.0	350.0	43.0

TUBE

*All dimensions are nominal

Device	Package Name	Package Type	Pins	SPQ	L (mm)	W (mm)	T (μm)	B (mm)
SN74HC646DW	DW	SOIC	24	25	506.98	12.7	4826	6.6

DW (R-PDSO-G24)

PLASTIC SMALL OUTLINE

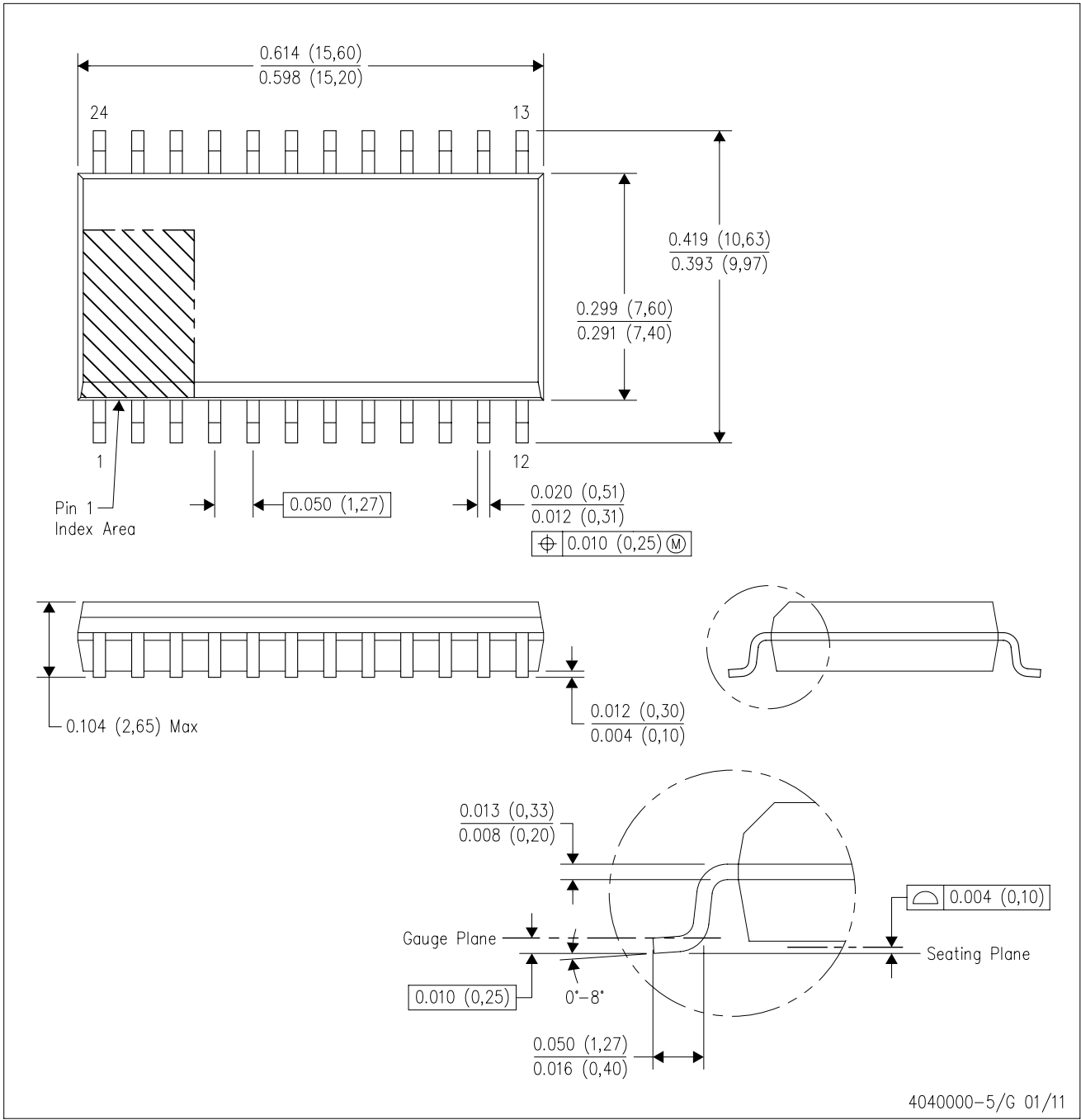

- NOTES:
- A. All linear dimensions are in inches (millimeters). Dimensioning and tolerancing per ASME Y14.5M-1994.
 - B. This drawing is subject to change without notice.
 - C. Body dimensions do not include mold flash or protrusion not to exceed 0.006 (0,15).
 - D. Falls within JEDEC MS-013 variation AD.

IMPORTANT NOTICE AND DISCLAIMER

TI PROVIDES TECHNICAL AND RELIABILITY DATA (INCLUDING DATA SHEETS), DESIGN RESOURCES (INCLUDING REFERENCE DESIGNS), APPLICATION OR OTHER DESIGN ADVICE, WEB TOOLS, SAFETY INFORMATION, AND OTHER RESOURCES "AS IS" AND WITH ALL FAULTS, AND DISCLAIMS ALL WARRANTIES, EXPRESS AND IMPLIED, INCLUDING WITHOUT LIMITATION ANY IMPLIED WARRANTIES OF MERCHANTABILITY, FITNESS FOR A PARTICULAR PURPOSE OR NON-INFRINGEMENT OF THIRD PARTY INTELLECTUAL PROPERTY RIGHTS.

These resources are intended for skilled developers designing with TI products. You are solely responsible for (1) selecting the appropriate TI products for your application, (2) designing, validating and testing your application, and (3) ensuring your application meets applicable standards, and any other safety, security, regulatory or other requirements.

These resources are subject to change without notice. TI grants you permission to use these resources only for development of an application that uses the TI products described in the resource. Other reproduction and display of these resources is prohibited. No license is granted to any other TI intellectual property right or to any third party intellectual property right. TI disclaims responsibility for, and you will fully indemnify TI and its representatives against, any claims, damages, costs, losses, and liabilities arising out of your use of these resources.

TI's products are provided subject to [TI's Terms of Sale](#) or other applicable terms available either on [ti.com](https://www.ti.com) or provided in conjunction with such TI products. TI's provision of these resources does not expand or otherwise alter TI's applicable warranties or warranty disclaimers for TI products.

TI objects to and rejects any additional or different terms you may have proposed.

Mailing Address: Texas Instruments, Post Office Box 655303, Dallas, Texas 75265
Copyright © 2023, Texas Instruments Incorporated