

THIS DRAWING IS UNPUBLISHED. RELEASED FOR PUBLICATION
 © COPYRIGHT BY TYCO ELECTRONICS CORPORATION. ALL RIGHTS RESERVED.

LOC	DIST	REVISIONS			
P	LTR	DESCRIPTION	DATE	DWN	APVD
AF	50	M	REV PER 0G3A-0747-04	08OCT2004	RF KR

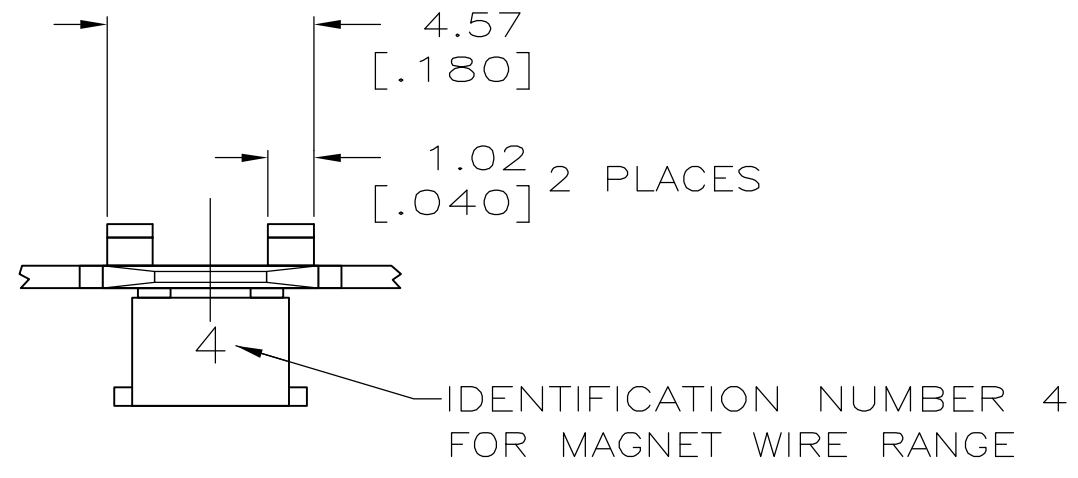

1 CONTINUOUS STRIP ON REELS WITH TERMINALS LOCATED ON 8.38 [.330] CENTERS.
 2 SLOT ACCEPTS 0.18-0.23mm [#33-#31] AWG COPPER MAGNET WIRE.
 2 WIRES OF THE SAME SIZE MAX PER SLOT.

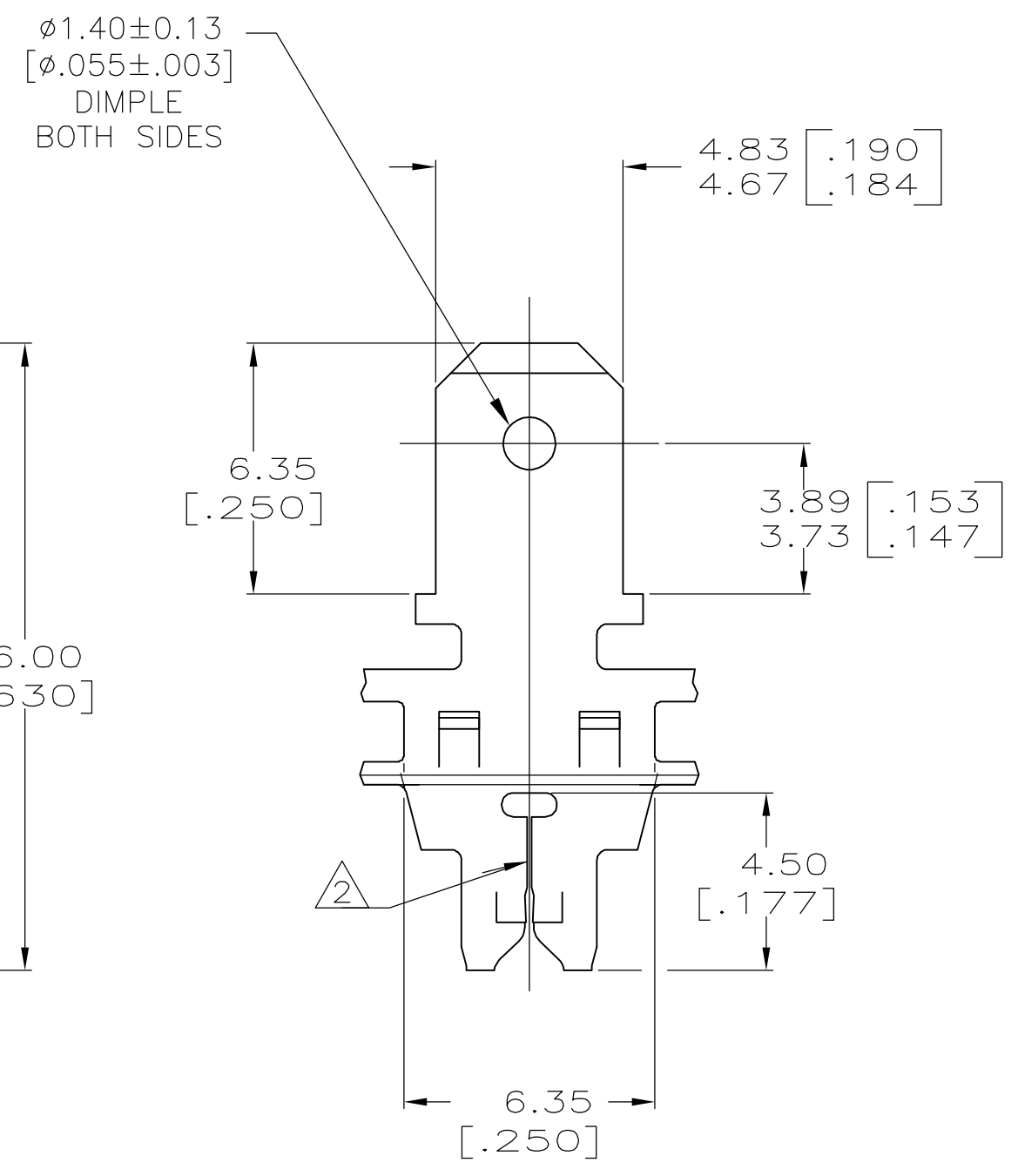
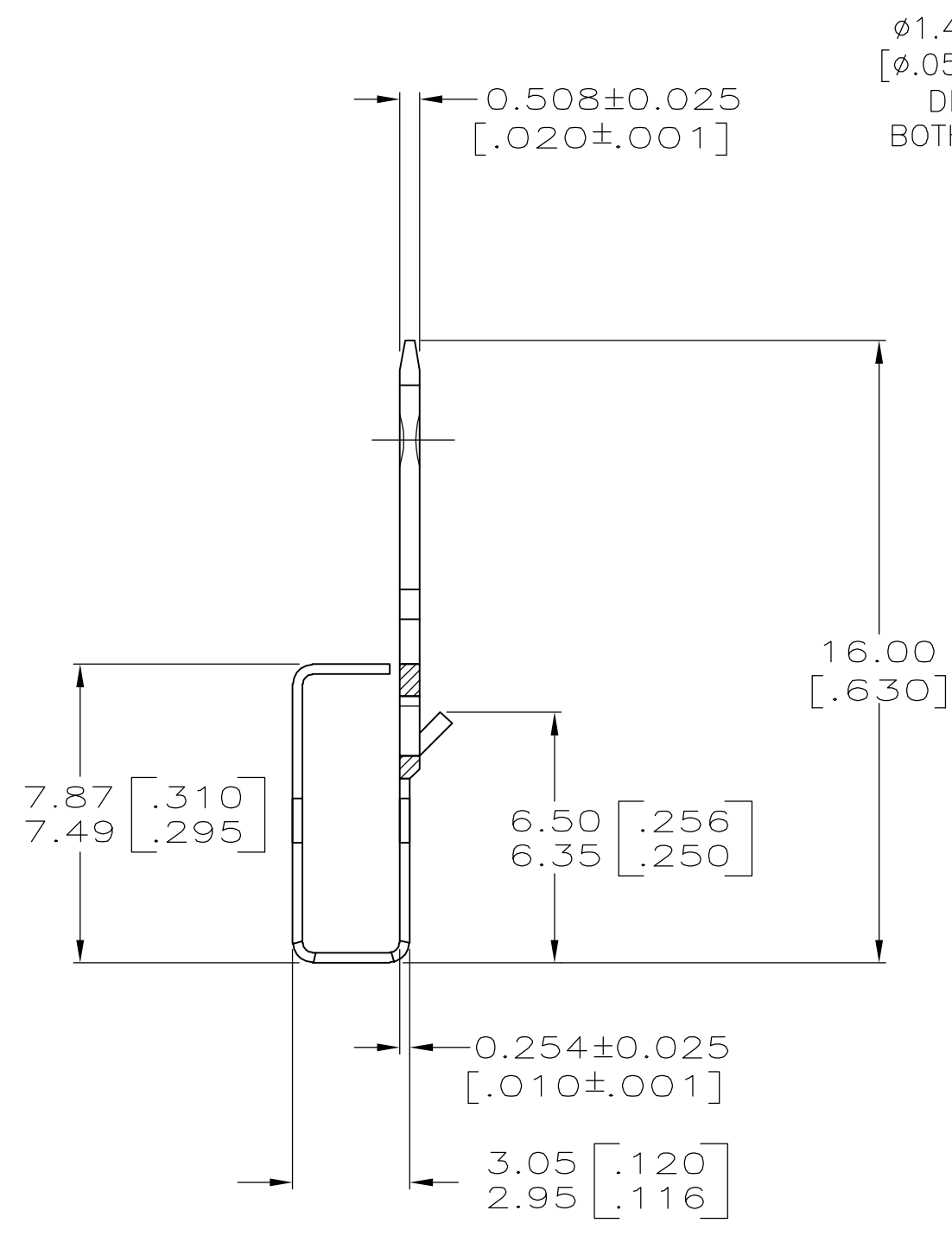
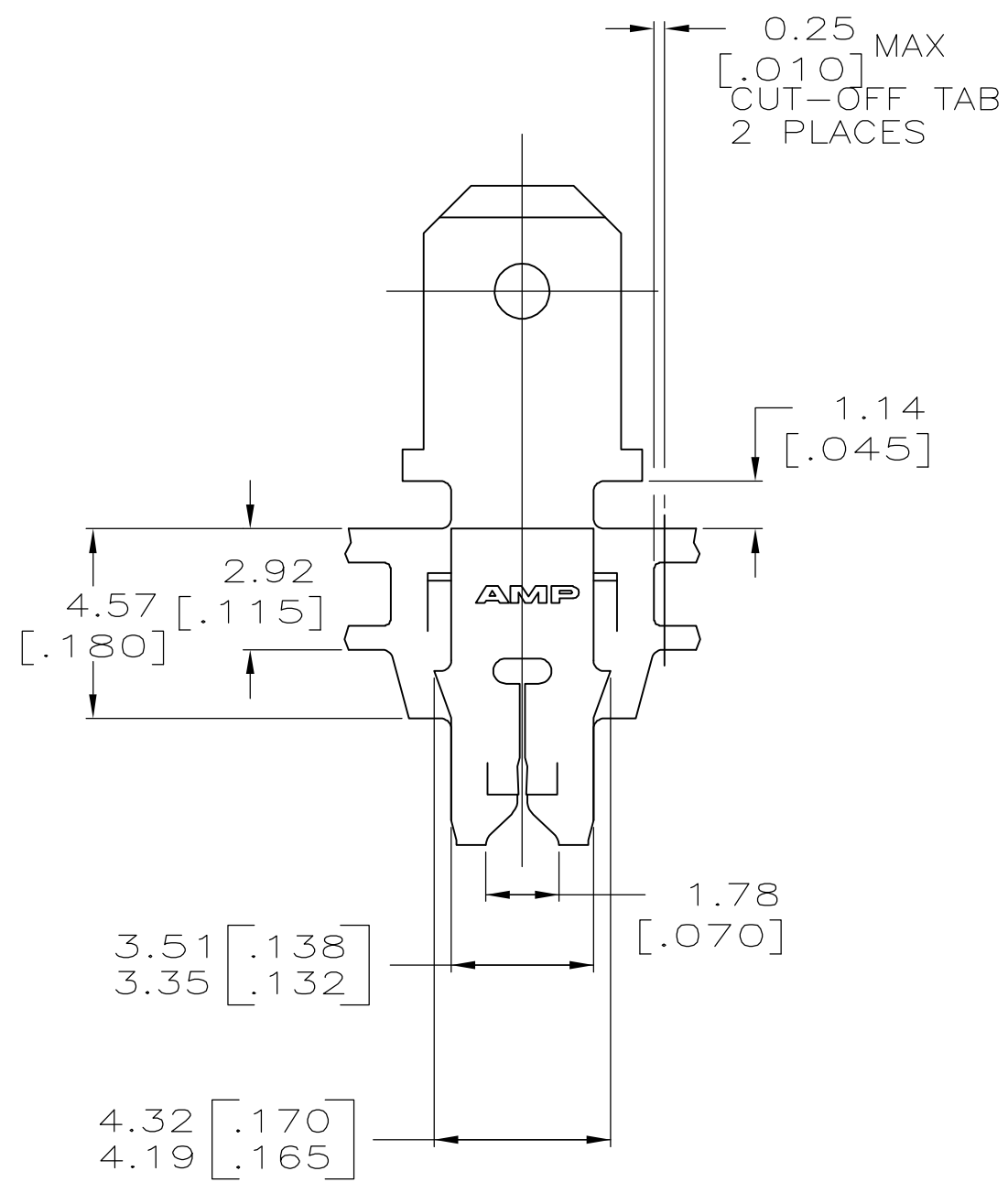

082 PRE-MILLED BRASS	63255-2
4M PRE-MILLED BRASS	63255-1
MATERIAL	PART NUMBER

THIS DRAWING IS A CONTROLLED DOCUMENT.		DWN 7/11/91 MICHAEL S. FEHER	Tyco Electronics Corporation Harrisburg, PA 17105-3608	
DIMENSIONS: INCHES		CHK 7/12/91 JEFF R. RUTH	NAME	
TOLERANCES UNLESS OTHERWISE SPECIFIED:		APVD -	PRODUCT SPEC	
0 PLC ± -		108-2012	4.75 [.187] FASTON, MAG-MATE	
1 PLC ± -		APPLICATION SPEC	SIZE CAGE CODE DRAWING NO RESTRICTED TO	
2 PLC ± 0.25 [.010]		114-2094	A2 00779 C=63255	-
3 PLC ± -		FINISH	SCALE 6:1	SHEET 1 OF 1
4 PLC ± -		0.00127 [.000050] MIN TIN	CUSTOMER DRAWING	REV M
ANGLES ± -				
MATERIAL SEE TABLE				