

THIS DRAWING IS UNPUBLISHED. RELEASED FOR PUBLICATION
 © COPYRIGHT BY TYCO ELECTRONICS CORPORATION. ALL INTERNATIONAL RIGHTS RESERVED.

LOC	DIST	REVISIONS					
		P	LTR	DESCRIPTION	DATE	DWN	APVD
HC	00	A		REDRAWN ON CAD ECN 92-0009	01-06-94		
		B		REVISED PER ECO-08-030676	27-02-09	AEG	JKO

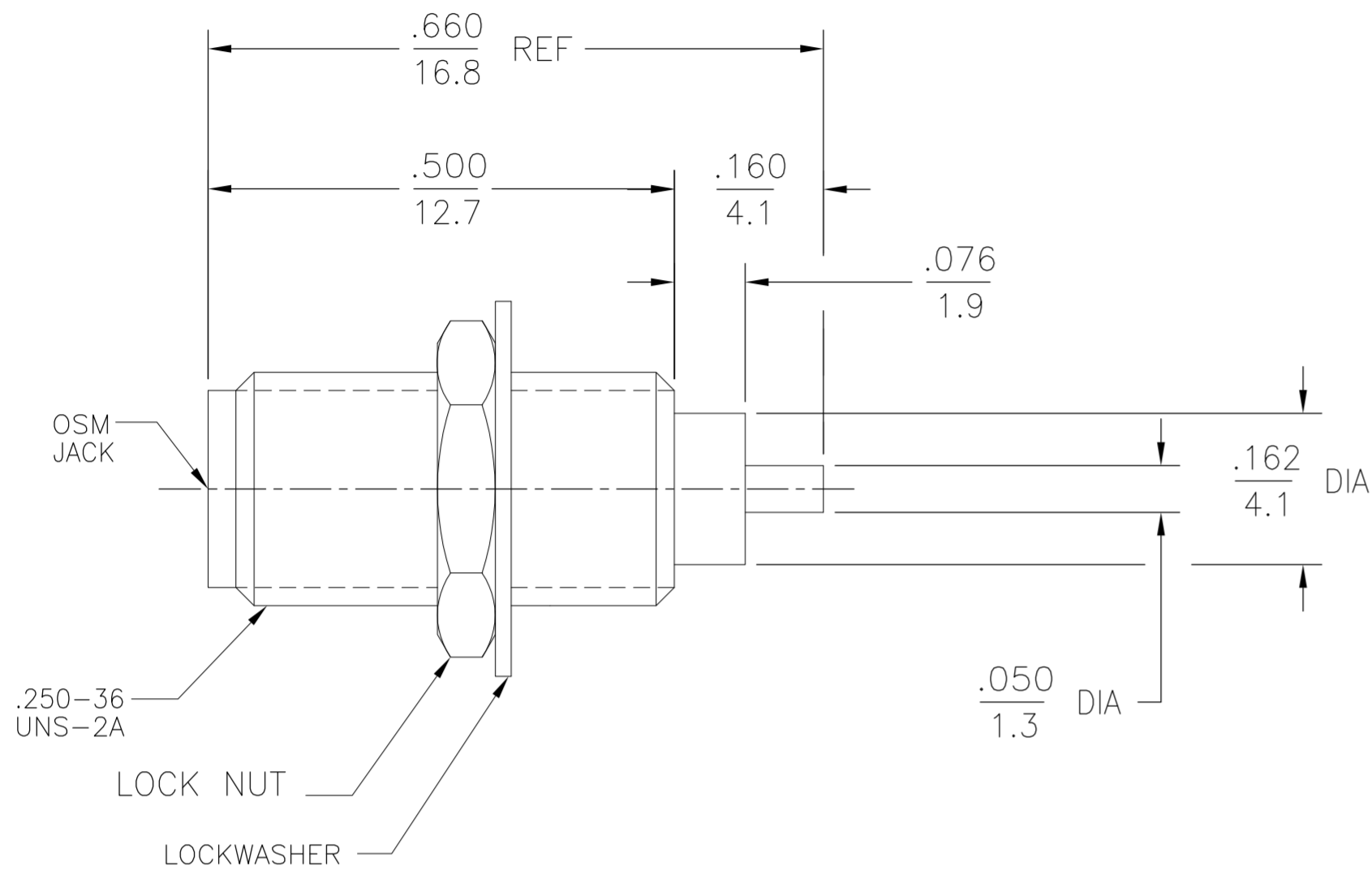

- ① BRASS
- ② STAINLESS STEEL
- ③ BERYLLIUM COPPER
- ④ PTFE
- ⑤ GOLD PLATE
- ⑥ PASSIVATED
- ⑦ SILICONE RUBBER
- ⑧ NICKEL PLATE

ELECTRICAL	MECHANICAL	ENVIRONMENTAL
Nominal Impedance (Ohms) <u>50</u>	Interface Dimensions MIL-STD-348A, Fig. <u>310.2</u>	TEMPERATURE RATING <u>-65°C TO 125°C</u>
Frequency Range (GHz) <u>DC to 18.0</u>	Recommended Mating Torque <u>7 to 10</u>	Vibration MIL-STD-202, Method 204, Condition D
Volt Rating (VRMS MAX) @ Sea Level <u>335</u>	Mating Characteristics: Insertion (MAX Lbs) <u>3.0</u>	Shock MIL-STD-202, Method 213, Condition I
VSWR <u>N/A</u>	Withdrawal (MIN Oz) <u>1.0</u>	Thermal Shock MIL-STD-202, Method 107, Condition B, EXCEPT HIGH TEMP +115°C
Insertion Loss (dB MAX) <u>N/A</u>	Force to Engage and Disengage (In-Lbs MAX) <u>2.0</u>	Moisture Resistance MIL-STD-202, Method 106, Except Vibration Shall Be Omitted
RF Leakage (dB MIN) <u>N/A</u>	Center Contact Captivation Axial (Lbs) <u>6.0</u>	Corrosion - MIL-STD-202, Method 101, Condition B, 5% salt spray
Dielectric Withstanding Voltage (VRMS MIN) @ Sea Level <u>1000</u>	Radial (In-Oz) <u>4.0</u>	
Contact Resistance (Milliohms MAX) Center Contact <u>2.0</u>	Cable Retention Axial Force (Lbs) <u>N/A</u>	
Outer Contact <u>2.0</u>	Torque (In-Oz) <u>N/A</u>	
Cable to Housing <u>N/A</u>	Weight (Grams) <u>TBD</u>	
RF High Potential @ Sea Level (VRMS MIN @ 5 MHz) <u>670</u>		
I.R.(Megohms MIN) <u>10,000</u>		

.XXX=INCHES
 X.X=MILLIMETERS

①⑤	①⑤	④	③⑤	①⑤	1053221-3
②⑤	②⑤	④	③⑤	②⑤	1053221-1
LOCKWASHER	MOUNTING NUT	DIELECTRIC	CONTACT	HOUSING	TE PN

THIS DRAWING IS A CONTROLLED DOCUMENT.		DWN <u>KWW.C.</u> 7/8/68	Tyco Electronics Corporation Harrisburg, PA 17105-3608		
DIMENSIONS: INCHES		CHK <u>P.R.B.</u> 7/8/68	NAME <u>OSM BULKHEAD FEEDTHRU JACK RECEPTACLE STRAIGHT TERMINAL</u>		
TOLERANCES UNLESS OTHERWISE SPECIFIED:		APVD <u>D.N.</u> 10/1/68	SIZE <u>A2</u>	CAGE CODE <u>00779</u>	DRAWING NO <u>C=1053221</u>
0 PLC ± -		PRODUCT SPEC	RESTRICTED TO		
1 PLC ± -		APPLICATION SPEC	SCALE <u>5:1</u> SHEET <u>1 of 1</u> REV <u>B</u>		
2 PLC ± -		WEIGHT			
3 PLC ± .005		CUSTOMER DRAWING			
4 PLC ± -					
ANGLES ± 1% _d					
FINISH					