

THIS DRAWING IS UNPUBLISHED. RELEASED FOR PUBLICATION
 © COPYRIGHT BY TYCO ELECTRONICS CORPORATION. ALL RIGHTS RESERVED.

LOC	DIST	REVISIONS					
		P	LTR	DESCRIPTION	DATE	DWN	APVD
AJ	16	0		REV PER EC-0S14-0496-04	31JAN2005	AF	JL
		01		REVISED PER ECO-09-024606	31OCT09	KK	AEG

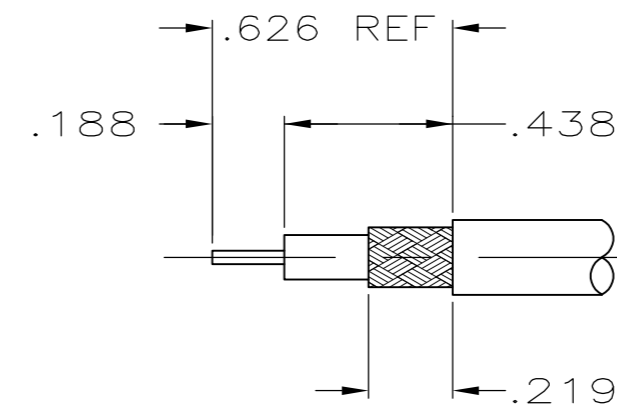
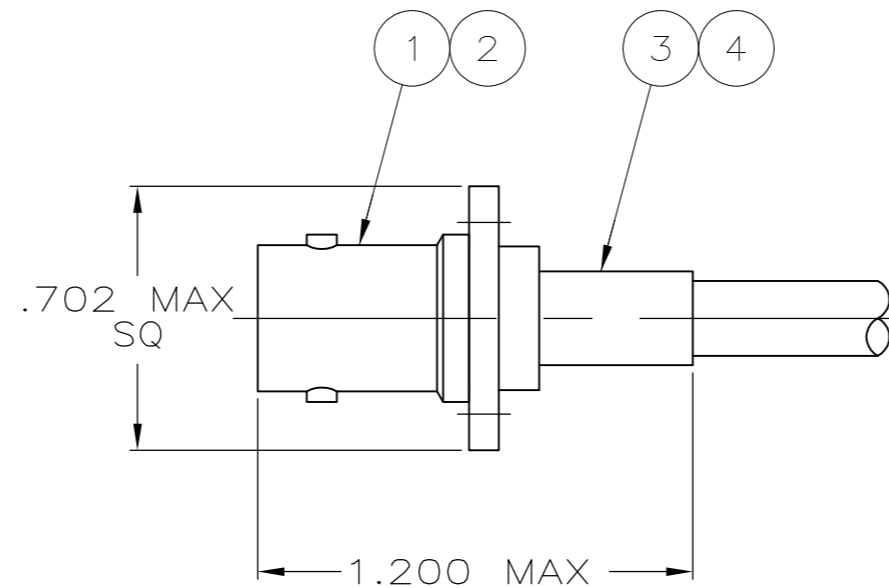
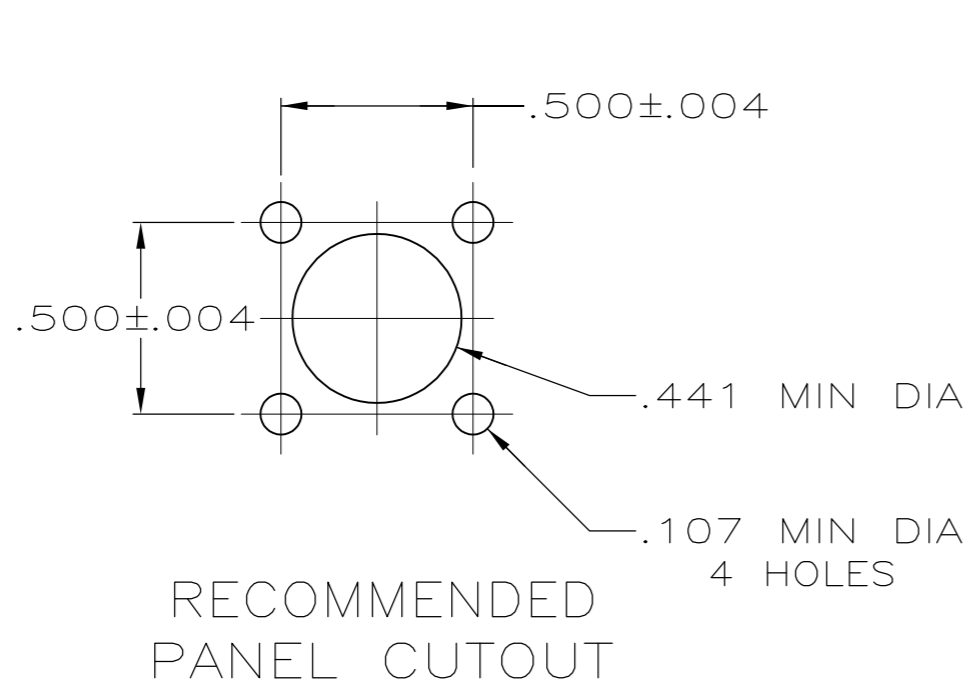

RECOMMENDED STRIP LENGTH

△ 1 SEE I.S. 1914-4

△ 2 OBSOLETE PARTS: OBSOLETE CIS STREAMLINING PER D.RENAUD/D.SINISI

	RG0174/U, 188/U, 316/U	220009-1	.023583 LB	21427-2	9-328666-0	1-331368-2	1-331791-4	5225397-7
	RG-59B/U & 62B/U	69477-1	.024369 LB	—————	9-50428-0	2-331368-3	1-331791-3	5225397-2
△ 2 OBSOLETE	RG-58/U, 58A/U, 58B/U & 58C/U	69478-1	.391 OZ	—————	9-50427-1	1-331369-6	1-331791-2	5225397-1
	FOR USE WITH CABLE:	CRIMPING TOOL	WEIGHT	④ BUSHING QTY=1	③ FERRULE QTY=1	② CONTACT QTY=1	① JACK ASSY, PANEL QTY=1	PART NO

THIS DRAWING IS A CONTROLLED DOCUMENT.

DWN	31JAN2005	Tyco Electronics Corporation Harrisburg, PA 17105-3608			
CHK	A. FERNANDEZ-DOCK5 31JAN2005				
APVD	J. LIPPERT 31JAN2005				
NAME	J. HAVENER				
PRODUCT SPEC	—	JACK, PANEL, DUAL CRIMP, BNC			
APPLICATION SPEC	—				
WEIGHT	—	SIZE	CAGE CODE	DRAWING NO	RESTRICTED TO
CUSTOMER DRAWING	—	A2	00779	C=5225397	—
SCALE		1:1	SHEET 1 OF 1		REV 01