

# HiPerDynFRED™ Epitaxial Diode

## ISOPLUS220™

### Electrically Isolated Back Surface

$$I_{FAV} = 15 \text{ A}$$

$$V_{RRM} = 600 \text{ V}$$

$$t_{rr} = 30 \text{ ns}$$

$V_{RRM}^{①}$	$V_{RRM}$	Type
V	V	
600	300	DSEE15-06CC

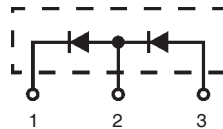

ISOPLUS 220  
E153432

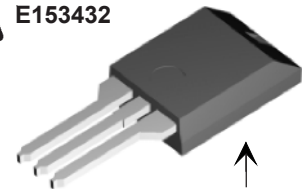

Isolated back surface\*

Symbol	Conditions	Maximum Ratings	
$I_{FRMS}$		35	A
$I_{FAVM}^{①}$	$T_C = 115^\circ\text{C}$ ; rectangular, $d = 0.5$	15	A
$I_{FSM}$	$T_{VJ} = 45^\circ\text{C}$ ; $t_p = 10 \text{ ms}$ (50 Hz), sine	110	A
$E_{AS}$	$T_{VJ} = 25^\circ\text{C}$ ; non-repetitive $I_{AS} = 2.5 \text{ A}$ ; $L = 180 \mu\text{H}$	0.8	mJ
$I_{AR}$	$V_A = 1.5 \cdot V_R$ typ.; $f = 10 \text{ kHz}$ ; repetitive	0.2	A
$T_{VJ}$		-55...+175	$^\circ\text{C}$
$T_{VJM}$		175	$^\circ\text{C}$
$T_{stg}$		-55...+150	$^\circ\text{C}$
$T_L$	1.6 mm (0.063 in) from case for 10 s	260	$^\circ\text{C}$
$P_{tot}$	$T_C = 25^\circ\text{C}$	95	W
$V_{ISOL}$	50/60 Hz RMS; $I_{ISOL} \leq 1 \text{ mA}$	2500	V~
$F_C$	Mounting force	11...65 / 2.5...15	N / lb
Weight	typical	2	g

### Features

- Silicon chip on Direct-Copper-Bond substrate
- High power dissipation
- Isolated mounting surface
- 2500V electrical isolation
- Low cathode to tab capacitance (<15pF)
- Planar passivated chips
- Very short recovery time
- Extremely low switching losses
- Low  $I_{RM}$ -values
- Soft recovery behaviour
- Epoxy meets UL 94V-0

### Applications

- Antiparallel diode for high frequency switching devices
- Antisaturation diode
- Snubber diode
- Free wheeling diode in converters and motor control circuits
- Rectifiers in switch mode power supplies (SMPS)
- Inductive heating
- Uninterruptible power supplies (UPS)
- Ultrasonic cleaners and welders

### Advantages

- Avalanche voltage rated for reliable operation
- Soft reverse recovery for low EMI/RFI
- Low  $I_{RM}$  reduces:
  - Power dissipation within the diode
  - Turn-on loss in the commutating switch

See DSEP 15-03A data sheet for characteristic curves.

**Recommended replacement:**  
**DSEE29-06CC**

Symbol	Conditions	Characteristic Values	
		typ.	max.
$I_R^{②}$	$T_{VJ} = 25^\circ\text{C}$ $V_R = V_{RRM}$ $T_{VJ} = 150^\circ\text{C}$ $V_R = V_{RRM}^{③}$		100 $\mu\text{A}$ 0.5 mA
$V_F$	$I_F = 15 \text{ A}$ ; $T_{VJ} = 125^\circ\text{C}$ $T_{VJ} = 25^\circ\text{C}$		1.25 V 1.7 V
$R_{thJC}$ $R_{thCH}$		0.6	1.6 K/W K/W
$t_{rr}$	$I_F = 1 \text{ A}$ ; $-di/dt = 200 \text{ A}/\mu\text{s}$ ; $V_R = 30 \text{ V}$	30	ns
$I_{RM}$	$V_R = 100 \text{ V}$ ; $I_F = 25 \text{ A}$ ; $-di_F/dt = 100 \text{ A}/\mu\text{s}$ $T_{VJ} = 100^\circ\text{C}$	2	2.7 A

Notes: Data given for  $T_{VJ} = 25^\circ\text{C}$  and per diode unless otherwise specified

① Diodes connected in series

② Pulse test: pulse Width = 5 ms, Duty Cycle < 2.0 %

③ Pulse test: pulse Width = 300  $\mu\text{s}$ , Duty Cycle < 2.0 %

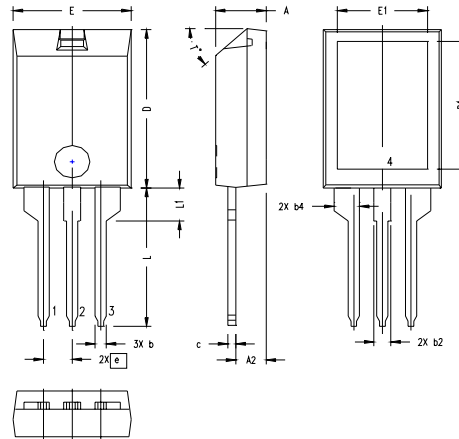
**ISOPLUS220 Outline**

SYM	INCHES		MILLIMETERS	
	MIN	MAX	MIN	MAX
A	.157	.197	4.00	5.00
A2	.098	.118	2.50	3.00
b	.035	.051	0.90	1.30
b2	.049	.065	1.25	1.65
b4	.093	.100	2.35	2.55
c	.028	.039	0.70	1.00
D	.591	.630	15.00	16.00
D1	.472	.512	12.00	13.00
E	.394	.433	10.00	11.00
E1	.295	.335	7.50	8.50
e	.100 BASIC		2.55 BASIC	
L	.512	.571	13.00	14.50
L1	.118	.138	3.00	3.50
T*			42.5°	47.5°

**NOTE:**

1. Bottom heatsink (Pin 4) is electrically isolated from Pin 1, 2 or 3.

2. Pin connections:

- 1 - Cathode
- 2 - Anode/Cathode
- 3 - Anode