

## Features

- EE Programmable 65,536 x 1-, 131,072 x 1-, 262,144 x 1-, 524,288 x 1-, 1,048,576 x 1- and 2,097,152 x 1-bit Serial Memories Designed to Store Configuration Programs for Altera® FLEX® and APEX™ FPGAs (Device Selection Guide Included)
- Available as a 3.3V (±10%) and 5.0V (±5% Commercial, ±10% Industrial) Version
- In-System Programmable (ISP) via 2-wire Bus
- Simple Interface to SRAM FPGAs
- Compatible with Atmel AT6000, AT40K and AT94K Devices, Altera FLEX, APEX Devices, ORCA® FPGAs, Xilinx® XC3000, XC4000, XC5200, Spartan®, Virtex™ FPGAs, Motorola MPA1000 FPGAs
- Cascadable Read-back to Support Additional Configurations or Higher-density Arrays
- Very Low-power CMOS EEPROM Process
- Programmable Reset Polarity
- Available 8-lead PDIP, 20-lead PLCC and 32-lead TQFP Packages (Pin Compatible Across Product Family)
- Emulation of Atmel's AT24CXXX Serial EEPROMs
- Low-power Standby Mode
- High-reliability
  - Endurance: 100,000 Write Cycles
  - Data Retention: 90 Years for Industrial Parts (at 85°C) and 190 Years for Commercial Parts (at 70°C)
- Green (Pb/Halide-free/RoHS Compliant) Package Options Available

## 1. Description

The AT17A series FPGA configuration EEPROMs (Configurators) provide an easy-to-use, cost-effective configuration memory for Field Programmable Gate Arrays. The AT17A series device is packaged in the 8-lead PDIP<sup>(1)</sup>, 20-lead PLCC and 32-lead TQFP, see [Table 1-1](#). The AT17A series configurator uses a simple serial-access procedure to configure one or more FPGA devices. The user can select the polarity of the reset function by programming four EEPROM bytes. These devices also support a write-protection mechanism within its programming mode.

Note: 1. The 8-lead LAP, PDIP and SOIC packages for the AT17LV65A/128A/256A do not have an A label. However, the 8-lead packages are pin compatible with the 8-lead package of Altera's EEPROMs, refer to the AT17LV65/128/256/512/010/002/040 datasheet available on the Atmel web site for more information.

The AT17A series configurators can be programmed with industry-standard programmers, Atmel's ATDH2200E Programming Kit or Atmel's ATDH2225 ISP Cable.

**Table 1-1.** AT17A Series Packages

Package	AT17LV65A/ AT17LV128A/ AT17LV256A	AT17LV512A	AT17LV010A	AT17LV002A
8-lead PDIP	Yes	Yes	Yes	–
20-lead PLCC	Yes	Yes	Yes	Yes
32-lead TQFP	–	–	Yes	Yes



## FPGA Configuration EEPROM Memory

**AT17LV65A**  
**AT17LV128A**  
**AT17LV256A**  
**AT17LV512A**  
**AT17LV010A**  
**AT17LV002A**

## 3.3V and 5V System Support



## 2. Pin Configuration

Figure 2-1. 8-lead PDIP

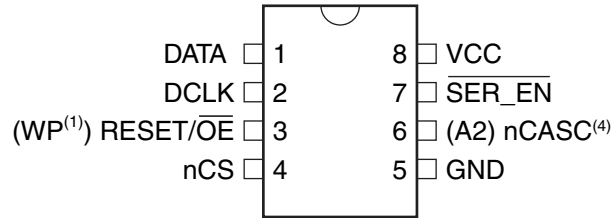

Figure 2-2. 20-lead PLCC

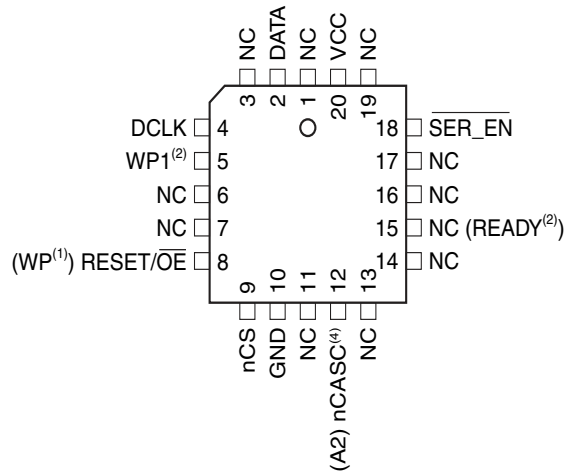
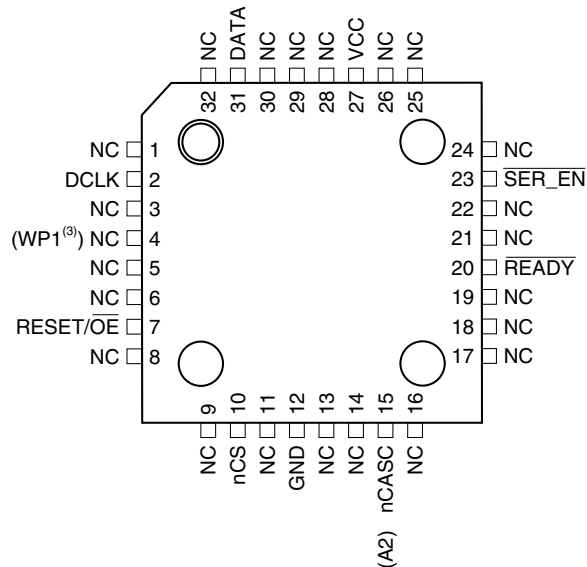
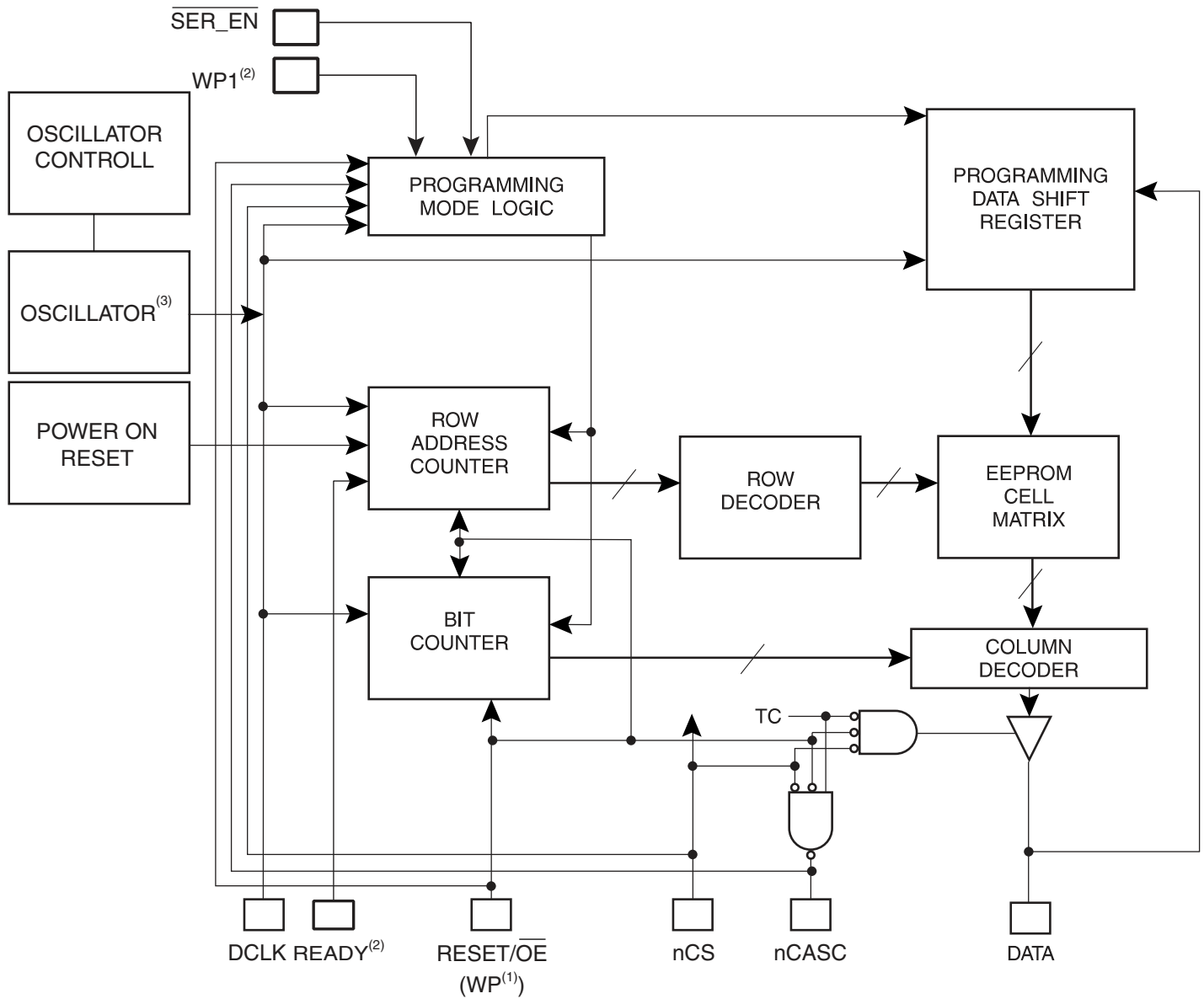

Figure 2-3. 32-lead TQFP



- Notes:
1. This pin is only available on AT17LV65A/128A/256A devices.
  2. This pin is only available on AT17LV512A/010A/002A devices.
  3. This pin is only available on AT17LV010A/002A devices.
  4. The nCASC feature is not available on the AT17LV65A device.

Figure 2-4. Block Diagram



- Notes:
1. This pin is only available on AT17LV65A/128A/256A devices.
  2. This pin is only available on AT17LV512A/010A/002A devices.
  3. The nCASC feature is not available on the AT17LV65A device.

### 3. Device Description

The control signals for the configuration EEPROM ( $\overline{\text{nCS}}$ ,  $\overline{\text{RESET/OE}}$  and  $\text{DCLK}$ ) interface directly with the FPGA device control signals. All FPGA devices can control the entire configuration process and retrieve data from the configuration EEPROM without requiring an external controller.

The configuration EEPROM's  $\overline{\text{RESET/OE}}$  and  $\overline{\text{nCS}}$  pins control the tri-state buffer on the  $\text{DATA}$  output pin and enable the address counter and the oscillator. When  $\overline{\text{RESET/OE}}$  is driven Low, the configuration EEPROM resets its address counter and tri-states its  $\text{DATA}$  pin. The  $\overline{\text{nCS}}$  pin also controls the output of the AT17A series configurator. If  $\overline{\text{nCS}}$  is held High after the  $\overline{\text{RESET/OE}}$  pulse, the counter is disabled and the  $\text{DATA}$  output pin is tri-stated. When  $\overline{\text{nCS}}$  is driven subsequently Low, the counter and the  $\text{DATA}$  output pin are enabled. When  $\overline{\text{RESET/OE}}$  is driven Low again, the address counter is reset and the  $\text{DATA}$  output pin is tri-stated, regardless of the state of the  $\overline{\text{nCS}}$ .

When the configurator has driven out all of its data and  $\overline{\text{nCASC}}$  is driven Low, the device tri-states the  $\text{DATA}$  pin to avoid contention with other configurators. Upon power-up, the address counter is automatically reset.

This is the default setting for the device. Since almost all FPGAs use  $\overline{\text{RESET}}$  Low and  $\text{OE}$  High, this document will describe  $\overline{\text{RESET/OE}}$ .

### 4. Pin Description

Name	I/O	AT17LV65A/ AT17LV128A/ AT17LV256A	AT17LV512A/ AT17LV010A			AT17LV002A	
		20 PLCC	8 PDIP	20 PLCC	32 TQFP	20 PLCC	32 TQFP
$\text{DATA}$	I/O	2	1	2	31	2	31
$\text{DCLK}$	I	4	2	4	2	4	2
$\text{WP1}$	I	–	–	5	4	5	4
$\overline{\text{RESET/OE}}$	I	8	3	8	7	8	7
$\overline{\text{nCS}}$	I	9	4	9	10	9	10
$\text{GND}$		10	5	10	12	10	12
$\overline{\text{nCASC}}$	O	12	6	12	15	12	15
$\text{A2}$	I						
$\text{READY}$	O	–	–	15	20	15	20
$\overline{\text{SER\_EN}}$	I	18	7	18	23	18	23
$\text{V}_{\text{CC}}$		20	8	20	27	20	27

Note: 1. The  $\overline{\text{nCASC}}$  feature is not available on the AT17LV65A device.

## 4.1 DATA

Three-state DATA output for configuration. Open-collector bi-directional pin for programming.

## 4.2 DCLK

Clock output or clock input. Rising edges on DCLK increment the internal address counter and present the next bit of data to the DATA pin. The counter is incremented only if the  $\overline{\text{RESET/OE}}$  input is held High, the  $\overline{\text{nCS}}$  input is held Low, and all configuration data has not been transferred to the target device (otherwise, as the master device, the DCLK pin drives Low).

## 4.3 WP1

WRITE PROTECT (1). This pin is used to protect portions of memory during programming, and it is disabled by default due to internal pull-down resistor. This input pin is not used during FPGA loading operations. This pin is only available on AT17LV512A/010A/002A devices.

## 4.4 $\overline{\text{RESET/OE}}$

Output Enable (active High) and RESET (active Low) when  $\overline{\text{SER\_EN}}$  is High. A Low logic level resets the address counter. A High logic level (with  $\overline{\text{nCS}}$  Low) enables DATA and permits the address counter to count. In the mode, if this pin is Low (reset), the internal oscillator becomes inactive and DCLK drives Low. The logic polarity of this input is programmable and must be programmed active High (RESET active Low) by the user during programming for Altera applications.

## 4.5 WP

Write protect (WP) input (when  $\overline{\text{nCS}}$  is Low) during programming only ( $\overline{\text{SER\_EN}}$  Low). When WP is Low, the entire memory can be written. When WP is enabled (High), the lowest block of the memory cannot be written. This pin is only available on AT17LV65A/128A/256A devices.

## 4.6 $\overline{\text{nCS}}$

Chip Select input (active Low). A Low input (with OE High) allows DCLK to increment the address counter and enables DATA to drive out. If the AT17A series is reset with  $\overline{\text{nCS}}$  Low, the device initializes as the first (and master) device in a daisy-chain. If the AT17A series is reset with  $\overline{\text{nCS}}$  High, the device initializes as a subsequent AT17A series device in the chain.

## 4.7 GND

Ground pin. A 0.2  $\mu\text{F}$  decoupling capacitor between  $V_{\text{CC}}$  and GND is recommended.

## 4.8 $\overline{\text{nCASC}}$

Cascade Select Output (active Low). This output goes Low when the address counter has reached its maximum value. In a daisy-chain of AT17A series devices, the  $\overline{\text{nCASC}}$  pin of one device is usually connected to the  $\overline{\text{nCS}}$  input pin of the next device in the chain, which permits DCLK from the master configurator to clock data from a subsequent AT17A series device in the chain. This feature is not available on the AT17LV65A device.

## 4.9 A2

Device selection input, A2. This is used to enable (or select) the device during programming (i.e., when  $\overline{\text{SER\_EN}}$  is Low). A2 has an internal pull-down resistor.

#### 4.10 READY

Open collector reset state indicator. Driven Low during power-on reset cycle, released when power-up is complete. (recommended 4.7 k $\Omega$  pull-up on this pin if used).

#### 4.11 $\overline{\text{SER\_EN}}$

Serial enable must be held High during FPGA loading operations. Bringing  $\overline{\text{SER\_EN}}$  Low enables the 2-wire Serial Programming Mode. For non-ISP applications,  $\overline{\text{SER\_EN}}$  should be tied to  $V_{\text{CC}}$ .

#### 4.12 $V_{\text{CC}}$

3.3V ( $\pm 10\%$ ) and 5.0V ( $\pm 5\%$  Commercial,  $\pm 10\%$  Industrial) power supply pin.

### 5. FPGA Master Serial Mode Summary

The I/O and logic functions of any SRAM-based FPGA are established by a configuration program. The program is loaded either automatically upon power-up, or on command, depending on the state of the FPGA mode pins. In Master mode, the FPGA automatically loads the configuration program from an external memory. The AT17A Serial Configuration EEPROM has been designed for compatibility with the Master Serial mode.

This document discusses the Altera FLEX FPGA device interfaces

### 6. Control of Configuration

Most connections between the FPGA device and the AT17A Serial EEPROM are simple and self-explanatory.

- The DATA output of the AT17A series configurator drives DIN of the FPGA devices.
- The master FPGA DCLK output or external clock source drives the DCLK input of the AT17A series configurator.
- The nCASC output of any AT17A series configurator drives the nCS input of the next configurator in a cascaded chain of EEPROMs.
- $\overline{\text{SER\_EN}}$  must be connected to  $V_{\text{CC}}$  (except during ISP).

### 7. Cascading Serial Configuration EEPROMs

For multiple FPGAs configured as a daisy-chain, or for FPGAs requiring larger configuration memories, cascaded configurators provide additional memory.

After the last bit from the first configurator is read, the next clock signal to the configurator asserts its nCASC output low and disables its DATA line driver. The second configurator recognizes the low level on its nCS input and enables its DATA output.

After configuration is complete, the address counters of all cascaded configurators are reset if the RESET/ $\overline{\text{OE}}$  on each configurator is driven to a Low level.

If the address counters are not to be reset upon completion, then the RESET/ $\overline{\text{OE}}$  input can be tied to a High level.

The AT17LV65A devices do not have the nCASC feature to perform cascaded configurations.

## 8. AT17A Series Reset Polarity

The AT17A series configurator allows the user to program the polarity of the RESET/ $\overline{OE}$  pin as either RESET/ $\overline{OE}$  or  $\overline{RESET/OE}$ . This feature is supported by industry-standard programmer algorithms.

## 9. Programming Mode

The programming mode is entered by bringing  $\overline{SER\_EN}$  Low. In this mode the chip can be programmed by the 2-wire serial bus. The programming is done at  $V_{CC}$  supply only. Programming super voltages are generated inside the chip.

## 10. Standby Mode

The AT17LV65A/128A/256A enters a low-power standby mode whenever nCS is asserted High. In this mode, the configurator consumes less than 50  $\mu A$  of current at 3.3V (100  $\mu A$  for the AT17LV512A/010A/002A). The output remains in a high-impedance state regardless of the state of the RESET/ $\overline{OE}$  input.

## 11. Absolute Maximum Ratings\*

Operating Temperature.....	-40°C to +85°C
Storage Temperature .....	-65°C to +150°C
Voltage on Any Pin with Respect to Ground .....	-0.1V to $V_{CC} + 0.5V$
Supply Voltage ( $V_{CC}$ ) .....	-0.5V to +7.0V
Maximum Soldering Temp. (10 sec. @ 1/16 in.).....	260°C
ESD ( $R_{ZAP} = 1.5K, C_{ZAP} = 100 pF$ ).....	2000V

\*NOTICE: Stresses beyond those listed under Absolute Maximum Ratings may cause permanent damage to the device. This is a stress rating only and functional operation of the device at these or any other conditions beyond those listed under operating conditions is not implied. Exposure to Absolute Maximum Rating conditions for extended periods of time may affect device reliability.

## 12. Operating Conditions

Symbol	Description		3.3V		5V		Units
			Min	Max	Min	Max	
$V_{CC}$	Commercial	Supply voltage relative to GND -0°C to +70°C	3.0	3.6	4.75	5.25	V
	Industrial	Supply voltage relative to GND -40°C to +85°C	3.0	3.6	4.5	5.5	V

### 13. DC Characteristics

$V_{CC} = 3.3V \pm 10\%$

Symbol	Description	AT17LV65A/ AT17LV128A/ AT17LV256A		AT17LV512A/ AT17LV010A		AT17LV002A		Units
		Min	Max	Min	Max	Min	Max	
$V_{IH}$	High-level Input Voltage	2.0	$V_{CC}$	2.0	$V_{CC}$	2.0	$V_{CC}$	V
$V_{IL}$	Low-level Input Voltage	0	0.8	0	0.8	0	0.8	V
$V_{OH}$	High-level Output Voltage ( $I_{OH} = -2.5$ mA)	2.4	0.4	2.4	0.4	2.4	0.4	V
$V_{OL}$	Low-level Output Voltage ( $I_{OL} = +3$ mA)							
$V_{OH}$	High-level Output Voltage ( $I_{OH} = -2$ mA)	2.4	0.4	2.4	0.4	2.4	0.4	V
$V_{OL}$	Low-level Output Voltage ( $I_{OL} = +3$ mA)							
$I_{CCA}$	Supply Current, Active Mode		5		5		5	mA
$I_L$	Input or Output Leakage Current ( $V_{IN} = V_{CC}$ or GND)	-10	10	-10	10	-10	10	$\mu$ A
$I_{CCS}$	Supply Current, Standby Mode	Commercial	50	100	150	$\mu$ A		
		Industrial	100	100	150	$\mu$ A		

### 14. DC Characteristics

$V_{CC} = 5V \pm 5\%$  Commercial;  $V_{CC} = 5V \pm 10\%$  Industrial

Symbol	Description	AT17LV65A/ AT17LV128A/ AT17LV256A		AT17LV512A/ AT17LV010A		AT17LV002A		Units
		Min	Max	Min	Max	Min	Max	
$V_{IH}$	High-level Input Voltage	2.0	$V_{CC}$	2.0	$V_{CC}$	2.0	$V_{CC}$	V
$V_{IL}$	Low-level Input Voltage	0	0.8	0	0.8	0	0.8	V
$V_{OH}$	High-level Output Voltage ( $I_{OH} = -2.5$ mA)	3.7	0.32	3.86	0.32	3.86	0.32	V
$V_{OL}$	Low-level Output Voltage ( $I_{OL} = +3$ mA)							
$V_{OH}$	High-level Output Voltage ( $I_{OH} = -2$ mA)	3.6	0.37	3.76	0.37	3.76	0.37	V
$V_{OL}$	Low-level Output Voltage ( $I_{OL} = +3$ mA)							
$I_{CCA}$	Supply Current, Active Mode		10		10		10	mA
$I_L$	Input or Output Leakage Current ( $V_{IN} = V_{CC}$ or GND)	-10	10	-10	10	-10	10	$\mu$ A
$I_{CCS1}$	Supply Current, Standby Mode	Commercial	75	200	350	$\mu$ A		
		Industrial	150	200	350	$\mu$ A		



### 15. AC Waveforms

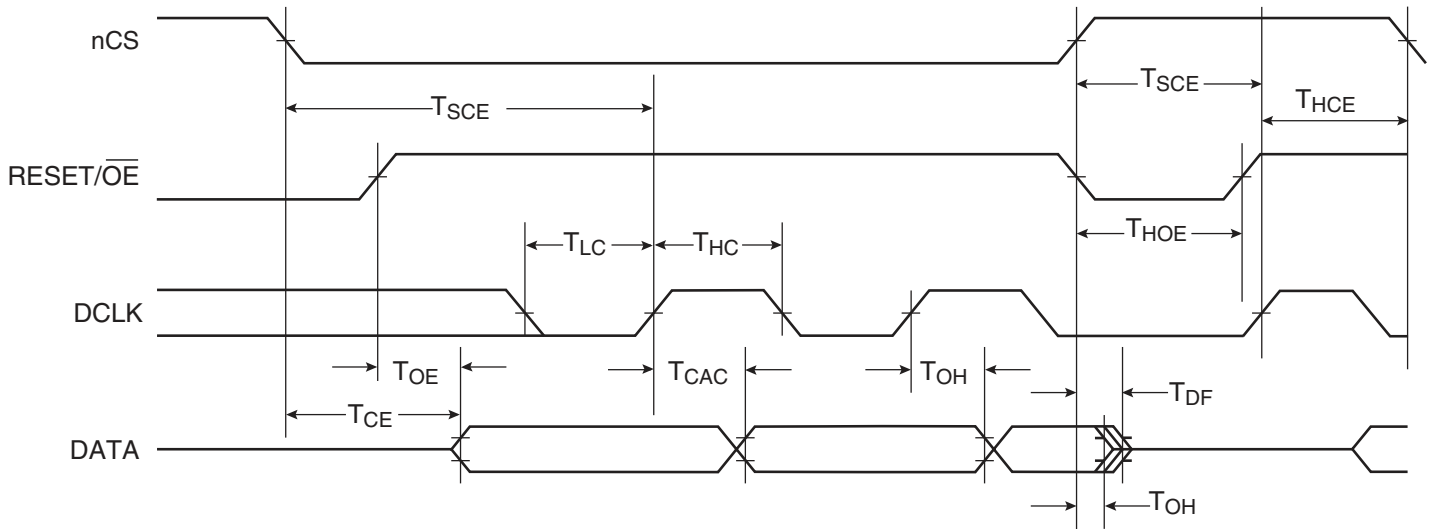

### 16. AC Waveforms when Cascading

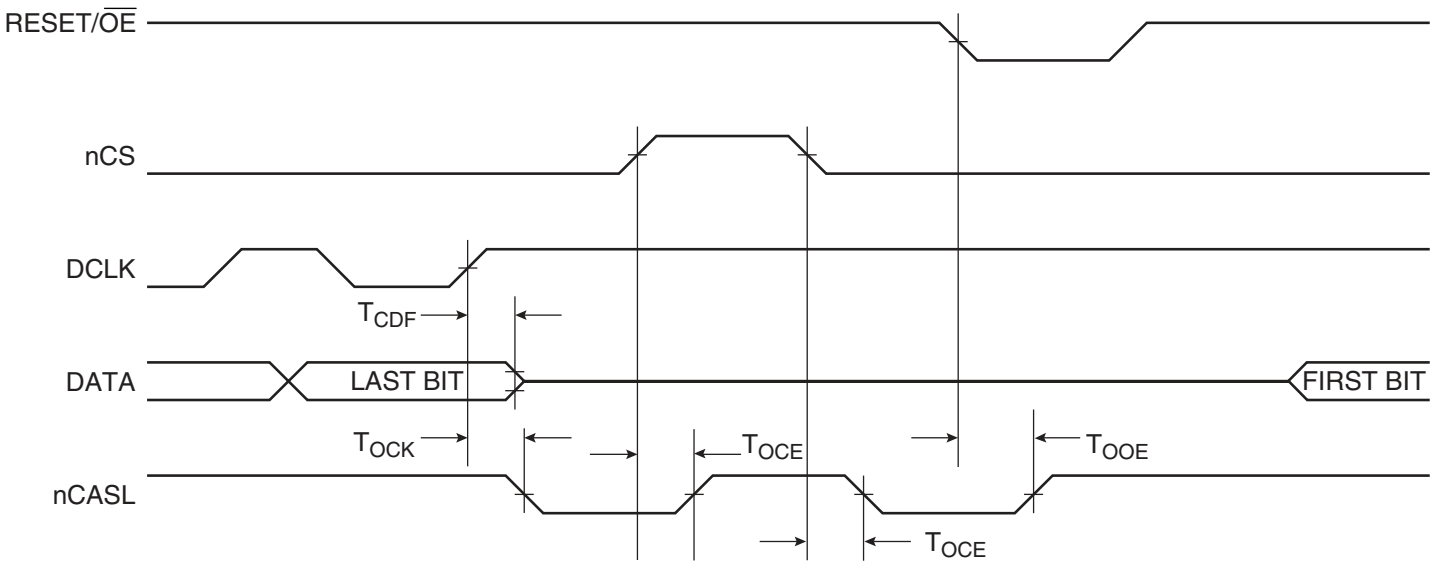

## 17. AC Characteristics

$$V_{CC} = 3.3V \pm 10\%$$

Symbol	Description	AT17LV65A/128A/256A				AT17LV512A/010A/002A				Units
		Commercial		Industrial		Commercial		Industrial		
		Min	Max	Min	Max	Min	Max	Min	Max	
$T_{OE}^{(1)}$	OE to Data Delay		50		55		50		55	ns
$T_{CE}^{(1)}$	$\overline{CE}$ to Data Delay		60		60		55		60	ns
$T_{CAC}^{(1)}$	CLK to Data Delay		75		80		55		60	ns
$T_{OH}$	Data Hold from $\overline{CE}$ , OE, or CLK	0		0		0		0		ns
$T_{DF}^{(2)}$	$\overline{CE}$ or OE to Data Float Delay		55		55		50		50	ns
$T_{LC}$	CLK Low Time	25		25		25		25		ns
$T_{HC}$	CLK High Time	25		25		25		25		ns
$T_{SCE}$	$\overline{CE}$ Setup Time to CLK (to guarantee proper counting)	35		60		30		35		ns
$T_{HCE}$	$\overline{CE}$ Hold Time from CLK (to guarantee proper counting)	0		0		0		0		ns
$T_{HOE}$	OE High Time (guarantees counter is reset)	25		25		25		25		ns
$F_{MAX}$	Maximum Input Clock Frequency	10		10		15		10		MHz

- Notes: 1. AC test lead = 50 pF.  
2. Float delays are measured with 5 pF AC loads. Transition is measured  $\pm 200$  mV from steady-state active levels.

## 18. AC Characteristics when Cascading

$$V_{CC} = 3.3V \pm 10\%$$

Symbol	Description	AT17LV65A/128A/256A				AT17LV512A/010A/002A				Units
		Commercial		Industrial		Commercial		Industrial		
		Min	Max	Min	Max	Min	Max	Min	Max	
$T_{CDF}^{(2)}$	CLK to Data Float Delay		60		60		50		50	ns
$T_{OCK}^{(1)}$	CLK to $\overline{CEO}$ Delay		55		60		50		55	ns
$T_{OCE}^{(1)}$	$\overline{CE}$ to $\overline{CEO}$ Delay		55		60		35		40	ns
$T_{OOE}^{(1)}$	RESET/OE to $\overline{CEO}$ Delay		40		45		35		35	ns
$F_{MAX}$	Maximum Input Clock Frequency	8		8		12.5		10		MHz

- Notes: 1. AC test lead = 50 pF.  
2. Float delays are measured with 5 pF AC loads. Transition is measured  $\pm 200$  mV from steady-state active levels.

## 19. AC Characteristics

$V_{CC} = 5V \pm 5\%$  Commercial;  $V_{CC} = 5V \pm 10\%$  Industrial

Symbol	Description	AT17LV65A/128A/256A				AT17LV512A/010A/002A				Units
		Commercial		Industrial		Commercial		Industrial		
		Min	Max	Min	Max	Min	Max	Min	Max	
$T_{OE}^{(1)}$	OE to Data Delay		30		35		30		35	ns
$T_{CE}^{(1)}$	$\overline{CE}$ to Data Delay		45		45		45		45	ns
$T_{CAC}^{(1)}$	CLK to Data Delay		50		55		50		50	ns
$T_{OH}$	Data Hold from $\overline{CE}$ , OE, or CLK	0		0		0		0		ns
$T_{DF}^{(2)}$	$\overline{CE}$ or OE to Data Float Delay		50		50		50		50	ns
$T_{LC}$	CLK Low Time	20		20		20		20		ns
$T_{HC}$	CLK High Time	20		20		20		20		ns
$T_{SCE}$	$\overline{CE}$ Setup Time to CLK (to guarantee proper counting)	35		40		20		25		ns
$T_{HCE}$	$\overline{CE}$ Hold Time from CLK (to guarantee proper counting)	0		0		0		0		ns
$T_{HOE}$	OE High Time (guarantees counter is reset)	20		20		20		20		ns
$F_{MAX}$	Maximum Input Clock Frequency	12.5		12.5		15		15		MHz

- Notes: 1. AC test lead = 50 pF.  
 2. Float delays are measured with 5 pF AC loads. Transition is measured  $\pm 200$  mV from steady-state active levels.

## 20. AC Characteristics when Cascading

$V_{CC} = 5V \pm 5\%$  Commercial;  $V_{CC} = 5V \pm 10\%$  Industrial

Symbol	Description	AT17LV65A/128A/256A				AT17LV512A/010A/002A				Units
		Commercial		Industrial		Commercial		Industrial		
		Min	Max	Min	Max	Min	Max	Min	Max	
$T_{CDF}^{(2)}$	CLK to Data Float Delay		50		50		50		50	ns
$T_{OCK}^{(1)}$	CLK to $\overline{CEO}$ Delay		35		40		35		40	ns
$T_{OCE}^{(1)}$	$\overline{CE}$ to $\overline{CEO}$ Delay		35		35		35		35	ns
$T_{OOE}^{(1)}$	$\overline{RESET}/OE$ to $\overline{CEO}$ Delay		30		35		30		30	ns
$F_{MAX}$	Maximum Input Clock Frequency	10		10		12.5		12.5		MHz

- Notes: 1. AC test lead = 50 pF.  
 2. Float delays are measured with 5 pF AC loads. Transition is measured  $\pm 200$  mV from steady-state active levels.

## 21. Thermal Resistance Coefficients<sup>(1)</sup>

Package Type			AT17LV65A/ AT17LV128A/ AT17LV256A	AT17LV512A/ AT17LV010A	AT17LV002A
8P3	Plastic Dual Inline Package (PDIP)	$\theta_{JC}$ [°C/W]		37	
		$\theta_{JA}$ [°C/W] <sup>(2)</sup>		107	
20J	Plastic Leaded Chip Carrier (PLCC)	$\theta_{JC}$ [°C/W]	35	35	35
		$\theta_{JA}$ [°C/W] <sup>(2)</sup>	90	90	90
32A	Thin Plastic Quad Flat Package (TQFP)	$\theta_{JC}$ [°C/W]			
		$\theta_{JA}$ [°C/W] <sup>(2)</sup>			
44J	Plastic Leaded Chip Carrier (PLCC)	$\theta_{JC}$ [°C/W]	–	–	15
		$\theta_{JA}$ [°C/W] <sup>(2)</sup>	–	–	50

- Notes: 1. For more information refer to the “Thermal Characteristics of Atmel’s Packages”, available on the Atmel web site.  
 2. Airflow = 0 ft/min.

## 22. Ordering Information

Figure 22-1. Ordering Code<sup>(1)</sup>

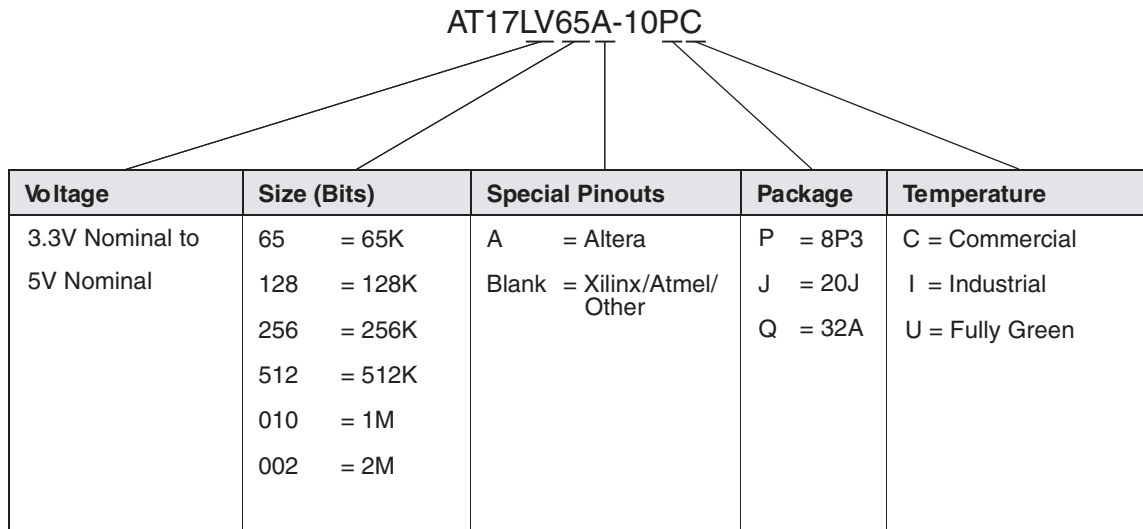

Note: 1. The 8-lead LAP and SOIC packages for the AT17LV65A/128A/256A do not have an A label. However, the 8-lead packages are pin compatible with the 8-lead package of Altera's EEPROMs, refer to the AT17LV65/128/256/512/010/002/040 datasheet available on the Atmel web site for more information.

Package Type	
<b>8P3</b>	8-lead, 0.300" Wide, Plastic Dual Inline Package (PDIP)
<b>20J</b>	20-lead, Plastic J-leaded Chip Carrier (PLCC)
<b>32A</b>	32-lead, Thin (1.0 mm) Plastic Quad Flat Package Carrier (TQFP)

## 22.1 Standard Package Options<sup>(1)</sup>

Memory Size	Ordering Code	Package	Operation Range
64-Kbit <sup>(2)(7)</sup>	AT17LV65A-10JC	20J	Commercial (0°C to 70°C)
	AT17LV65A-10JI	20J	Industrial (-40°C to 85°C)
128-Kbit <sup>(7)</sup>	AT17LV128A-10JC	20J	Commercial (0°C to 70°C)
	AT17LV128A-10JI	20J	Industrial (-40°C to 85°C)
256-Kbit <sup>(3)(7)</sup>	AT17LV256A-10JC	20J	Commercial (0°C to 70°C)
	AT17LV256A-10JI	20J	Industrial (-40°C to 85°C)
512-Kbit <sup>(4)(7)</sup>	AT17LV512A-10PC AT17LV512A-10JC	8P3 20J	Commercial (0°C to 70°C)
	AT17LV512A-10PI AT17LV512A-10JI	8P3 20J	Industrial (-40°C to 85°C)
1-Mbit <sup>(5)(7)</sup>	AT17LV010A-10PC AT17LV010A-10JC AT17LV010A-10QC	8P3 20J 32A	Commercial (0°C to 70°C)
	AT17LV010A-10PI AT17LV010A-10JI AT17LV010A-10QI	8P3 20J 32A	Industrial (-40°C to 85°C)
2-Mbit <sup>(6)(7)</sup>	AT17LV002A-10JC AT17LV002A-10QC	20J 32A	Commercial (0°C to 70°C)
	AT17LV002A-10JI AT17LV002A-10QI	20J 32A	Industrial (-40°C to 85°C)

## 22.2 Green Package Options (Pb/Halide-free/RoHS Compliant)<sup>(1)</sup>

Memory Size	Ordering Code	Package	Operation Range
512-Kbit <sup>(4)(7)</sup>	AT17LV512A-10JU	20J	Industrial (-40°C to 85°C)
1-Mbit <sup>(5)(7)</sup>	AT17LV010A-10JU	20J	Industrial (-40°C to 85°C)
	AT17LV010A-10PU	8P3	Industrial (-40°C to 85°C)
2-Mbit <sup>(4)(7)</sup>	AT17LV002A-10JU	20J	Industrial (-40°C to 85°C)

- Notes:
- Currently, there are two types of low-density configurators. The new version will be identified by a "B" after the datacode. The "B" version is fully backward-compatible with the original devices so existing customers will not be affected. The new parts no longer require a MUX for ISP. See programming specification for more details.
  - Use 64-Kbit density parts to replace Altera EPC1064.
  - Use 256-Kbit density parts to replace Altera EPC1213.
  - Use 512-Kbit density parts to replace Altera EPC1441.
  - Use 1-Mbit density parts to replace Altera EPC1
  - Use 2-Mbit density parts to replace Altera EPC2. Atmel AT17LV002A devices do not support JTAG programming; Atmel AT17LV002A devices use a 2-wire serial interface for in-system programming.
  - For operating voltage of 5V ±10%, please refer to the 5V ±10% AC and DC Characteristics.

## 23. Packaging Information

### 23.1 8P3 – PDIP

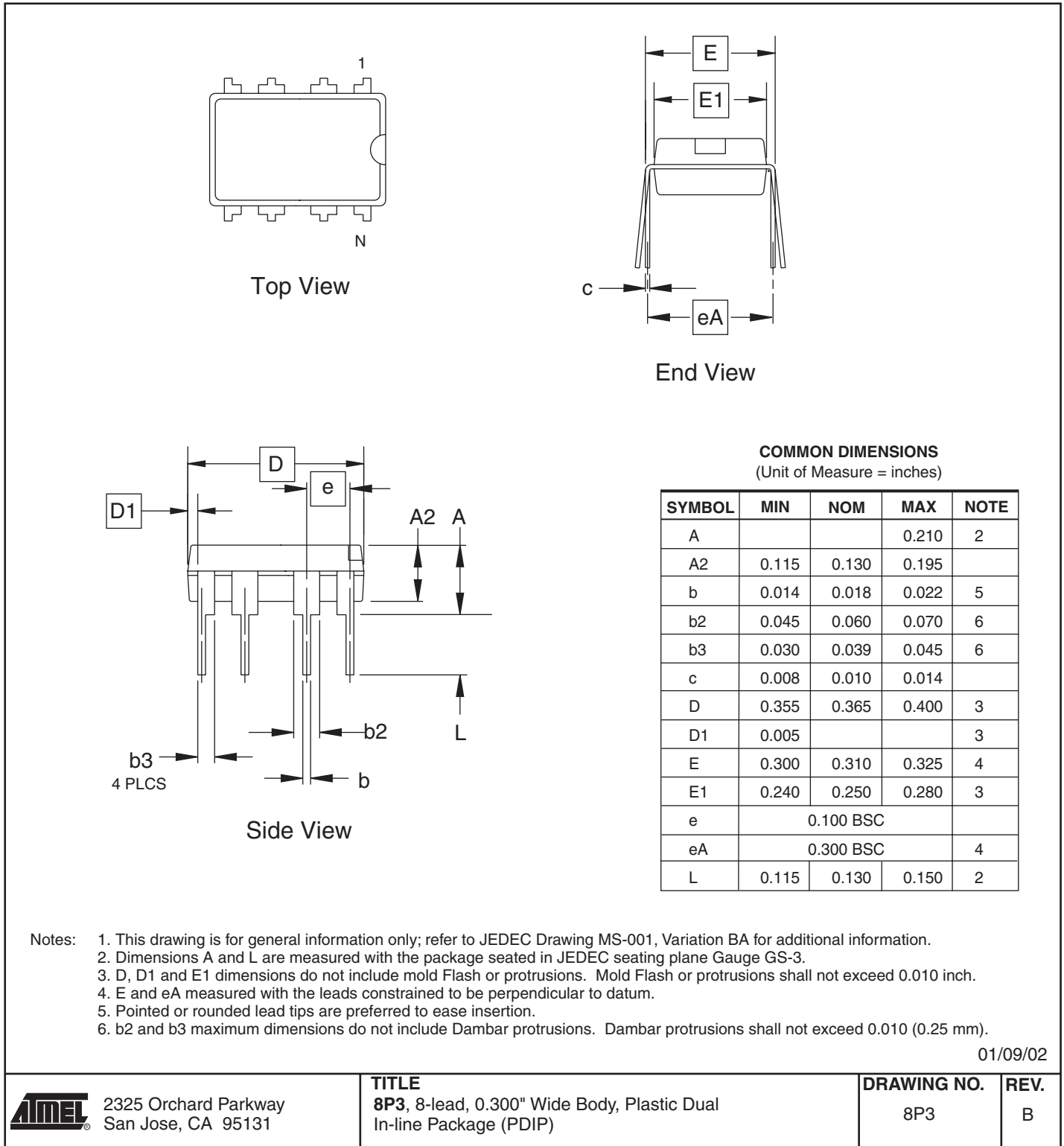

### 23.2 20J – PLCC

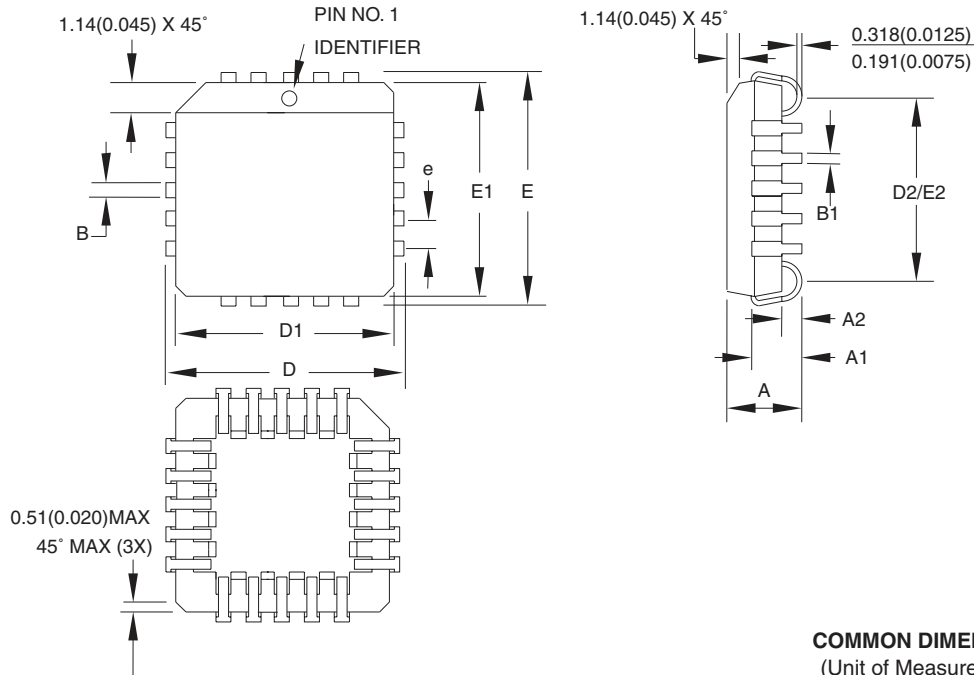

**COMMON DIMENSIONS**  
(Unit of Measure = mm)

SYMBOL	MIN	NOM	MAX	NOTE
A	4.191	–	4.572	
A1	2.286	–	3.048	
A2	0.508	–	–	
D	9.779	–	10.033	
D1	8.890	–	9.042	Note 2
E	9.779	–	10.033	
E1	8.890	–	9.042	Note 2
D2/E2	7.366	–	8.382	
B	0.660	–	0.813	
B1	0.330	–	0.533	
e	1.270 TYP			

- Notes:
1. This package conforms to JEDEC reference MS-018, Variation AA.
  2. Dimensions D1 and E1 do not include mold protrusion. Allowable protrusion is .010" (0.254 mm) per side. Dimension D1 and E1 include mold mismatch and are measured at the extreme material condition at the upper or lower parting line.
  3. Lead coplanarity is 0.004" (0.102 mm) maximum.

10/04/01



2325 Orchard Parkway  
San Jose, CA 95131

**TITLE**

**20J, 20-lead, Plastic J-leaded Chip Carrier (PLCC)**

**DRAWING NO.**

20J

**REV.**

B



## 23.3 32A – TQFP

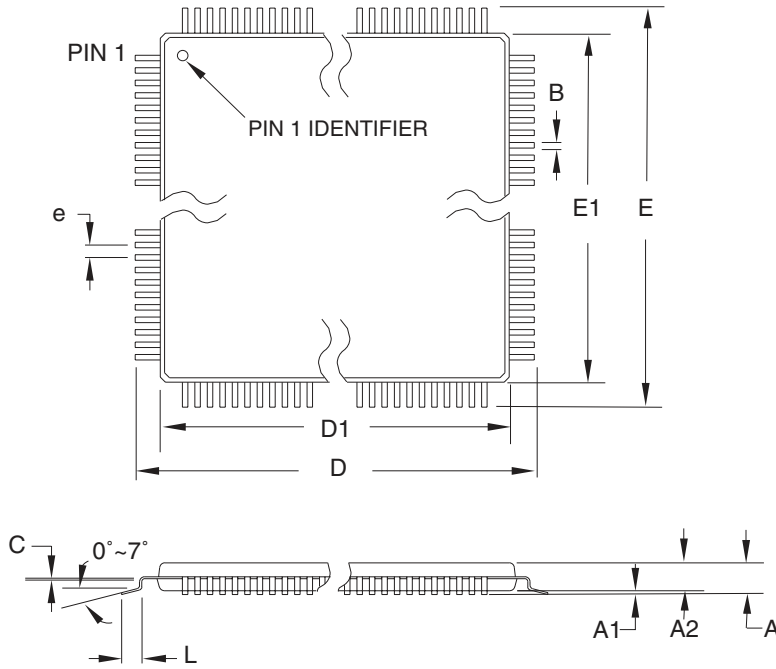

**COMMON DIMENSIONS**  
(Unit of Measure = mm)

SYMBOL	MIN	NOM	MAX	NOTE
A	–	–	1.20	
A1	0.05	–	0.15	
A2	0.95	1.00	1.05	
D	8.75	9.00	9.25	
D1	6.90	7.00	7.10	Note 2
E	8.75	9.00	9.25	
E1	6.90	7.00	7.10	Note 2
B	0.30	–	0.45	
C	0.09	–	0.20	
L	0.45	–	0.75	
e	0.80 TYP			

- Notes:
1. This package conforms to JEDEC reference MS-026, Variation ABA.
  2. Dimensions D1 and E1 do not include mold protrusion. Allowable protrusion is 0.25 mm per side. Dimensions D1 and E1 are maximum plastic body size dimensions including mold mismatch.
  3. Lead coplanarity is 0.10 mm maximum.

10/5/2001

 2325 Orchard Parkway San Jose, CA 95131	<b>TITLE</b> <b>32A</b> , 32-lead, 7 x 7 mm Body Size, 1.0 mm Body Thickness, 0.8 mm Lead Pitch, Thin Profile Plastic Quad Flat Package (TQFP)	<b>DRAWING NO.</b>	<b>REV.</b>
		32A	B



## Atmel Corporation

2325 Orchard Parkway  
San Jose, CA 95131, USA  
Tel: 1(408) 441-0311  
Fax: 1(408) 487-2600

## Regional Headquarters

### Europe

Atmel Sarl  
Route des Arsenalux 41  
Case Postale 80  
CH-1705 Fribourg  
Switzerland  
Tel: (41) 26-426-5555  
Fax: (41) 26-426-5500

### Asia

Room 1219  
Chinachem Golden Plaza  
77 Mody Road Tsimshatsui  
East Kowloon  
Hong Kong  
Tel: (852) 2721-9778  
Fax: (852) 2722-1369

### Japan

9F, Tonetsu Shinkawa Bldg.  
1-24-8 Shinkawa  
Chuo-ku, Tokyo 104-0033  
Japan  
Tel: (81) 3-3523-3551  
Fax: (81) 3-3523-7581

## Atmel Operations

### Memory

2325 Orchard Parkway  
San Jose, CA 95131, USA  
Tel: 1(408) 441-0311  
Fax: 1(408) 436-4314

### Microcontrollers

2325 Orchard Parkway  
San Jose, CA 95131, USA  
Tel: 1(408) 441-0311  
Fax: 1(408) 436-4314

La Chantrerie  
BP 70602  
44306 Nantes Cedex 3, France  
Tel: (33) 2-40-18-18-18  
Fax: (33) 2-40-18-19-60

### ASIC/ASSP/Smart Cards

Zone Industrielle  
13106 Rousset Cedex, France  
Tel: (33) 4-42-53-60-00  
Fax: (33) 4-42-53-60-01

1150 East Cheyenne Mtn. Blvd.  
Colorado Springs, CO 80906, USA  
Tel: 1(719) 576-3300  
Fax: 1(719) 540-1759

Scottish Enterprise Technology Park  
Maxwell Building  
East Kilbride G75 0QR, Scotland  
Tel: (44) 1355-803-000  
Fax: (44) 1355-242-743

### RF/Automotive

Theresienstrasse 2  
Postfach 3535  
74025 Heilbronn, Germany  
Tel: (49) 71-31-67-0  
Fax: (49) 71-31-67-2340

1150 East Cheyenne Mtn. Blvd.  
Colorado Springs, CO 80906, USA  
Tel: 1(719) 576-3300  
Fax: 1(719) 540-1759

### Biometrics/Imaging/Hi-Rel MPU/ High Speed Converters/RF Datacom

Avenue de Rochepleine  
BP 123  
38521 Saint-Egreve Cedex, France  
Tel: (33) 4-76-58-30-00  
Fax: (33) 4-76-58-34-80

**Atmel Programmable SLI Hotline**  
(408) 436-4119

**Atmel Programmable SLI e-mail**  
configurator@atmel.com

**FAQ**  
Available on web site

**Literature Requests**  
[www.atmel.com/literature](http://www.atmel.com/literature)

**Disclaimer:** The information in this document is provided in connection with Atmel products. No license, express or implied, by estoppel or otherwise, to any intellectual property right is granted by this document or in connection with the sale of Atmel products. **EXCEPT AS SET FORTH IN ATMEL'S TERMS AND CONDITIONS OF SALE LOCATED ON ATMEL'S WEB SITE, ATMEL ASSUMES NO LIABILITY WHATSOEVER AND DISCLAIMS ANY EXPRESS, IMPLIED OR STATUTORY WARRANTY RELATING TO ITS PRODUCTS INCLUDING, BUT NOT LIMITED TO, THE IMPLIED WARRANTY OF MERCHANTABILITY, FITNESS FOR A PARTICULAR PURPOSE, OR NON-INFRINGEMENT. IN NO EVENT SHALL ATMEL BE LIABLE FOR ANY DIRECT, INDIRECT, CONSEQUENTIAL, PUNITIVE, SPECIAL OR INCIDENTAL DAMAGES (INCLUDING, WITHOUT LIMITATION, DAMAGES FOR LOSS OF PROFITS, BUSINESS INTERRUPTION, OR LOSS OF INFORMATION) ARISING OUT OF THE USE OR INABILITY TO USE THIS DOCUMENT, EVEN IF ATMEL HAS BEEN ADVISED OF THE POSSIBILITY OF SUCH DAMAGES.** Atmel makes no representations or warranties with respect to the accuracy or completeness of the contents of this document and reserves the right to make changes to specifications and product descriptions at any time without notice. Atmel does not make any commitment to update the information contained herein. Unless specifically provided otherwise, Atmel products are not suitable for, and shall not be used in, automotive applications. Atmel's products are not intended, authorized, or warranted for use as components in applications intended to support or sustain life.

© Atmel Corporation 2006. All rights reserved. Atmel®, logo and combinations thereof, Everywhere You Are® and others, are registered trademarks or trademarks of Atmel Corporation or its subsidiaries. Other terms and product names may be trademarks of others.



Printed on recycled paper.

2322G-CNFG-03/06