

# ISL68300EVAL3Z

User's Manual: Evaluation Board

Core Power Solutions

## ISL68300EVAL3Z

Evaluation Board

UG173  
Rev.0.00  
Jul 12, 2018

## 1. Overview

The [ISL68300](#) is a PMBus compliant, single-phase digital DC/DC controller with integrated gate drivers for use with N-channel MOSFETs. The ISL68300 implements the Renesas fully digital ChargeMode™ control modulation scheme, allowing both ease of use and industry leading performance. ChargeMode control provides an inherently stable control loop that can respond to load transients in a single switching cycle, significantly decreasing output capacitor requirements.

A dedicated current share bus allows for paralleling up to eight devices in a current share configuration, allowing support for a wide range of load currents.

The ISL68300EVAL3Z evaluation board is a 2.7inx3.0in 6-layer FR4 board with 2oz. copper on all layers. This evaluation board comes with a placeholder for pin-strap resistors to adjust output voltage, switching frequency, and the device PMBus address. More configurations, such as soft-start and fault limits, can be easily programmed or changed using a PMBus compliant serial bus interface.

This evaluation board includes the ZLUSBEVAL3Z (USB to PMBus adapter), which connects the evaluation board to a PC to activate the PMBus communication interface. The PMBus command set is accessed by using the [PowerNavigator™](#) evaluation software from a PC running Microsoft Windows.

### 1.1 Key Features

- $V_{IN}$  range of 4.5V to 16V,  $V_{OUT}$  adjustable from 0.5V to 2.5V
- Programmable  $V_{OUT}$ , margining, UV/OV,  $I_{OUT}$  limit, soft-start/stop, sequencing, and external synchronization
- Monitor:  $V_{IN}$ ,  $V_{OUT}$ ,  $I_{OUT}$ , temperature, duty cycle, switching frequency, and faults
- ChargeMode control tunable with PMBus
- On-board load step circuit
- Mechanical switch for enable and power-good LED indicator

### 1.2 Specifications

This board highlights the current-sharing feature of the ISL68300 in the 2-phase configuration. It is configured for the following operating conditions by default:

- $V_{IN} = 7V$  to 16V
- $V_{OUT} = 1.0V$
- $I_{MAX} = 60A$
- $f_{SW} = 400kHz$
- Peak efficiency: >89% at 50% load
- On/off delay = 5ms, on/off ramp time = 5ms

### 1.3 Ordering Information

Part Number	Description
ISL68300EVAL3Z	ISL68300 evaluation board (EVB, ZLUSBEVAL3Z adapter, USB cable)

### 1.4 Related Literature

For a full list of related documents, visit our website

- [ISL68300](#) product page

### 1.5 Recommended Equipment

- DC power supply with minimum 15V/25A sourcing capacity
- Electronic load capable of sinking current up to 80A
- Digital Multimeters (DMMs)
- Oscilloscope with higher than 100MHz bandwidth

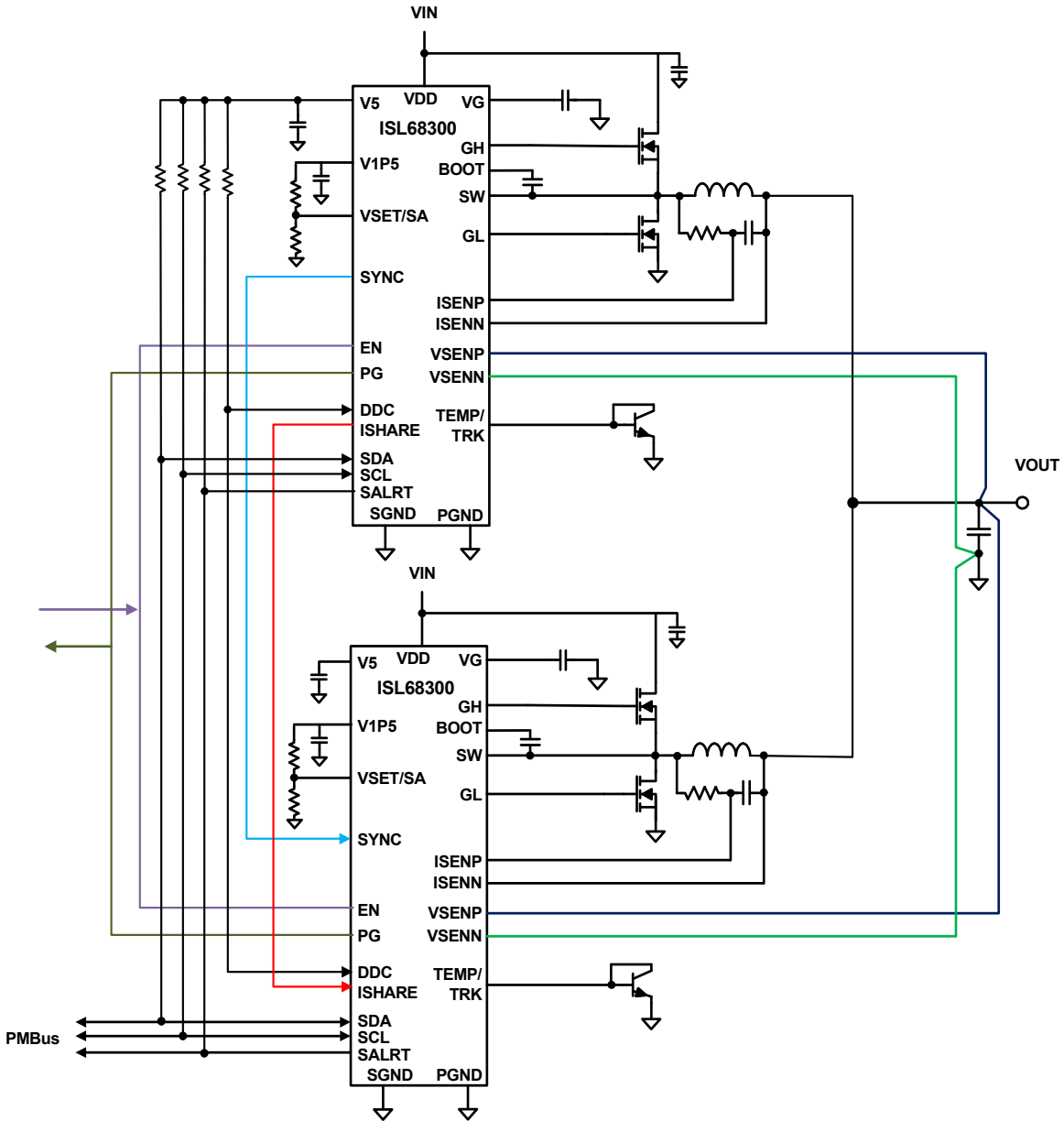

Figure 1. ISL68300EVAL3Z Block Diagram

## 2. Functional Description

The ISL68300EVAL3Z provides all circuitry required to evaluate the features of the ISL68300. A majority of the features of the ISL68300, such as compensation-free ChargeMode control, soft-start delay and ramp times, supply sequencing, and voltage margining are available on this evaluation board. For sequencing evaluation, the board can be connected to any Renesas digital module evaluation board that supports the Digital-DC™ (DDC) bus.

[Figures 2](#) and [3](#) on [page 6](#) show the ISL68300EVAL3Z evaluation board.

### 2.1 Operating Range

By default, the ISL68300EVAL3Z is configured to operate at  $V_{OUT} = 1.0V$ ,  $f_{SW} = 400kHz$ .  $V_{IN}$  ranges from 7V to 16V. The board can also support a wider operating range to meet the requirements of specific applications. The  $V_{OUT}$  can be adjusted from 0.5V to 2.5V, the load current range is from 0A to 60A, and the switching frequency can also be tuned.

If using external synchronization, connect the SYNC test point to the external clock. Note that the external clock signal should be valid before the ISL68300s are enabled.

### 2.2 PMBus Operation

The ISL68300 uses the PMBus protocol. The PMBus functionality can be controlled using the ZLUSBEVAL3Z dongle from a PC running the PowerNavigator evaluation software.

Install PowerNavigator from the Renesas [website](#).

For board operation, connect the included ZLUSBEVAL3Z dongle to the 6 pin male connector, J3, labeled “DONGLE”. Connect the desired load and an appropriate power supply to the input and connect the included USB cable to the PC running PowerNavigator. Set the ENABLE switch, SW3, to “OFF” before turning on the power.

PowerNavigator allows modification of all ISL68300 PMBus parameters. The user can modify the operating parameters through the evaluation software or by loading a predefined set-up from a configuration file.

The ENABLE switch, SW3, can then be moved to “ON” and the ISL68300EVAL3Z board can be tested. Alternately, the PMBus ON\_OFF\_CONFIG and OPERATION commands can be used from PowerNavigator.

## 2.3 Quick Start Guide

### 2.3.1 PMBus Option

The ISL68300EVAL3Z can be evaluated for all features using the provided ZLUSBEVAL3Z dongle and PowerNavigator. Complete the following steps to evaluate the ISL68300 with the PMBus option.

- (1) Install PowerNavigator.
- (2) Set the ENABLE switch to “OFF”.
- (3) Connect the load to the VOUT lug connectors.
- (4) Connect the power supply to the VIN connectors. Make sure the power supply is not enabled when making the connection.
- (5) Turn the power supply on.
- (6) Connect the ZLUSBEVAL3Z dongle (USB to PMBus adapter) to the ISL68300EVAL3Z board to the 6-pin male connector, J3, labeled “DONGLE”.
- (7) Connect the supplied USB cable from the computer through the USB to the ZLUSBEVAL3Z dongle.
- (8) Launch PowerNavigator.
- (9) Set the ENABLE switch to “ON”.
- (10) Monitor and configure the ISL68300EVAL3Z board using the PMBus commands in the evaluation software.

PowerNavigator tutorial videos are available on the Renesas [website](#).

To sequence using the Digital-DC Bus (DDC), or to evaluate multiple Renesas digital power products using a single ZLUSBEVAL3Z dongle, the ISL68300 can be daisy chained with other digital power evaluation boards. The PMBus address can be changed by placing 1% standard 0402 resistors at R<sub>3</sub>, R<sub>5</sub>, R<sub>8</sub>, and R<sub>10</sub>. Refer to the “Output Voltage and SMBus Address Selection” table in the [ISL68300](#) datasheet for recommended values.

### 3. PCB Layout Guidelines

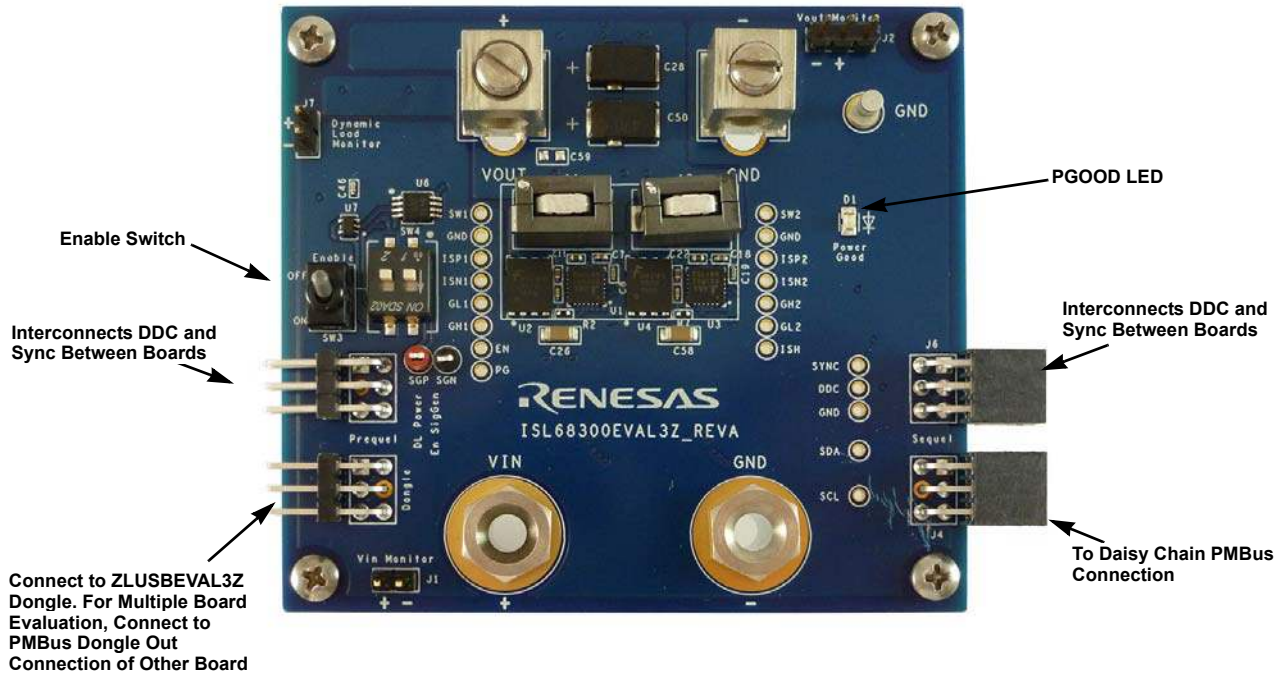

Figure 2. ISL68300EVAL3Z Evaluation Board (Top Side)

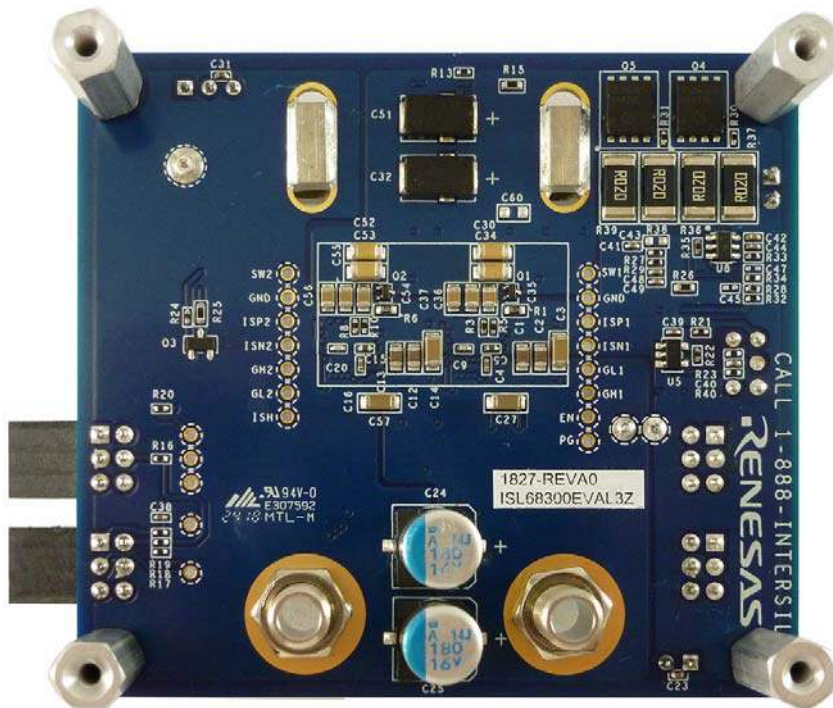

Figure 3. ISL68300EVAL3Z Evaluation Board (Bottom Side)

### 3.1 ISL68300EVAL3Z Board Schematic

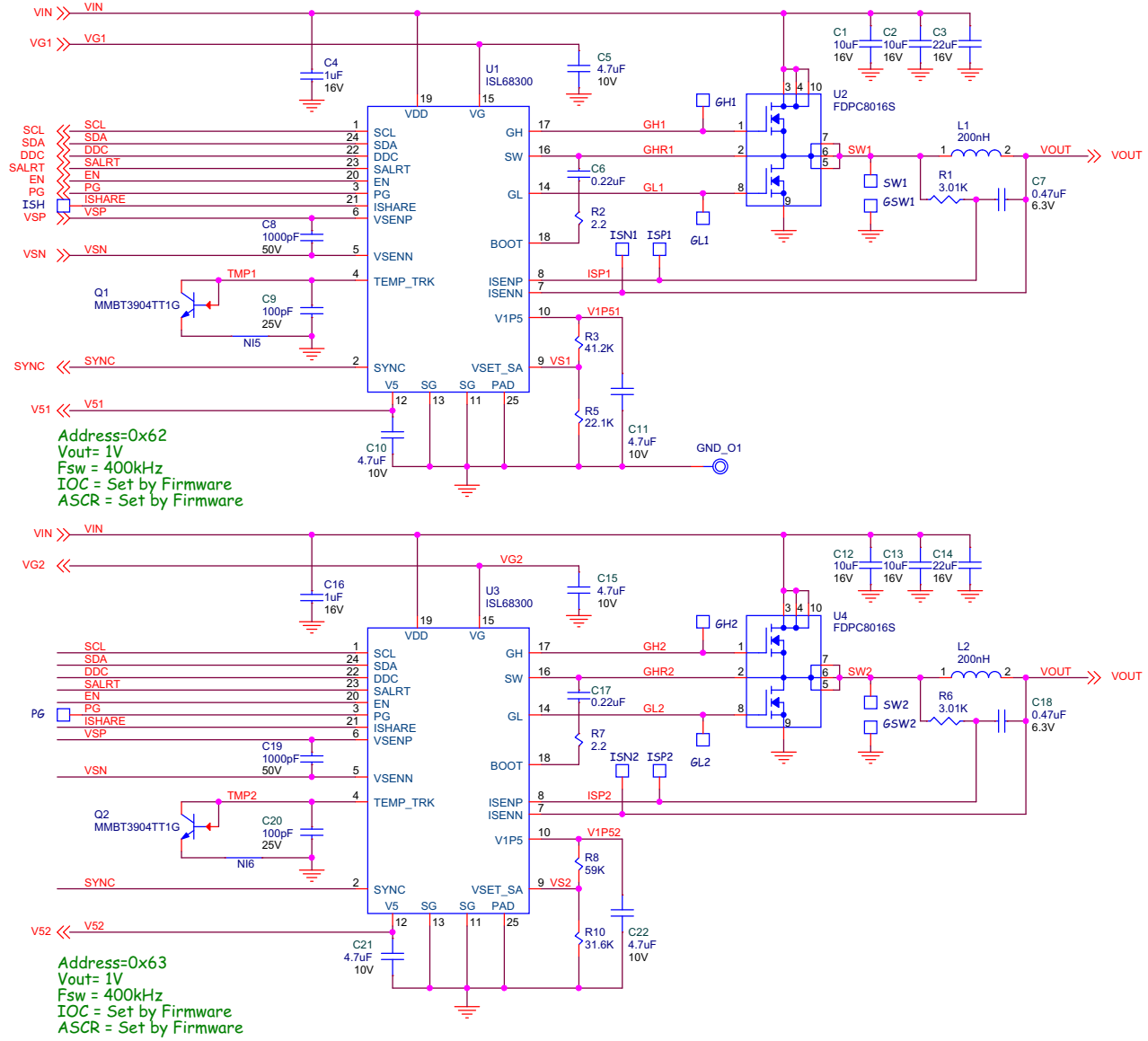

Figure 4. Schematic

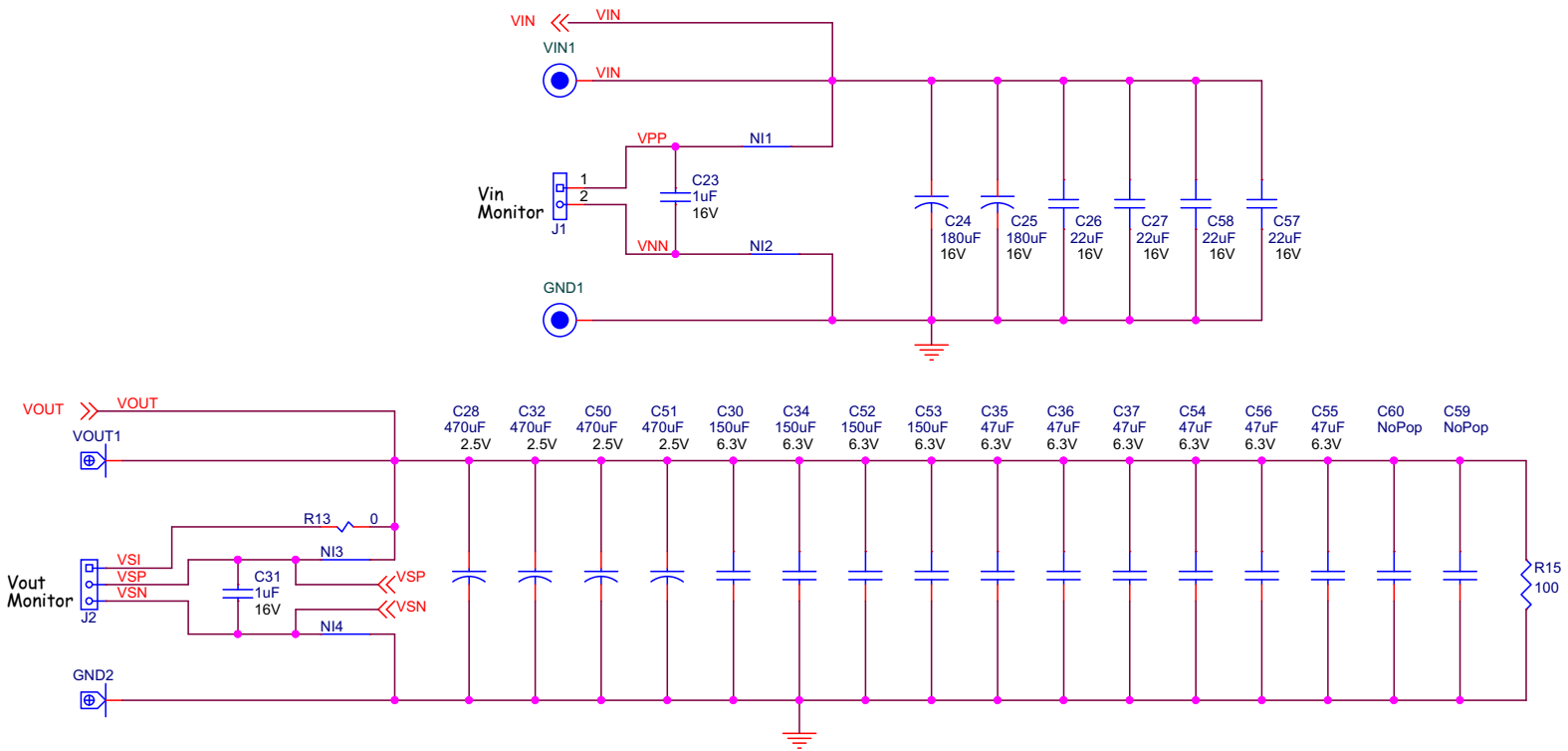

Figure 5. Schematic - Input and Output Filters



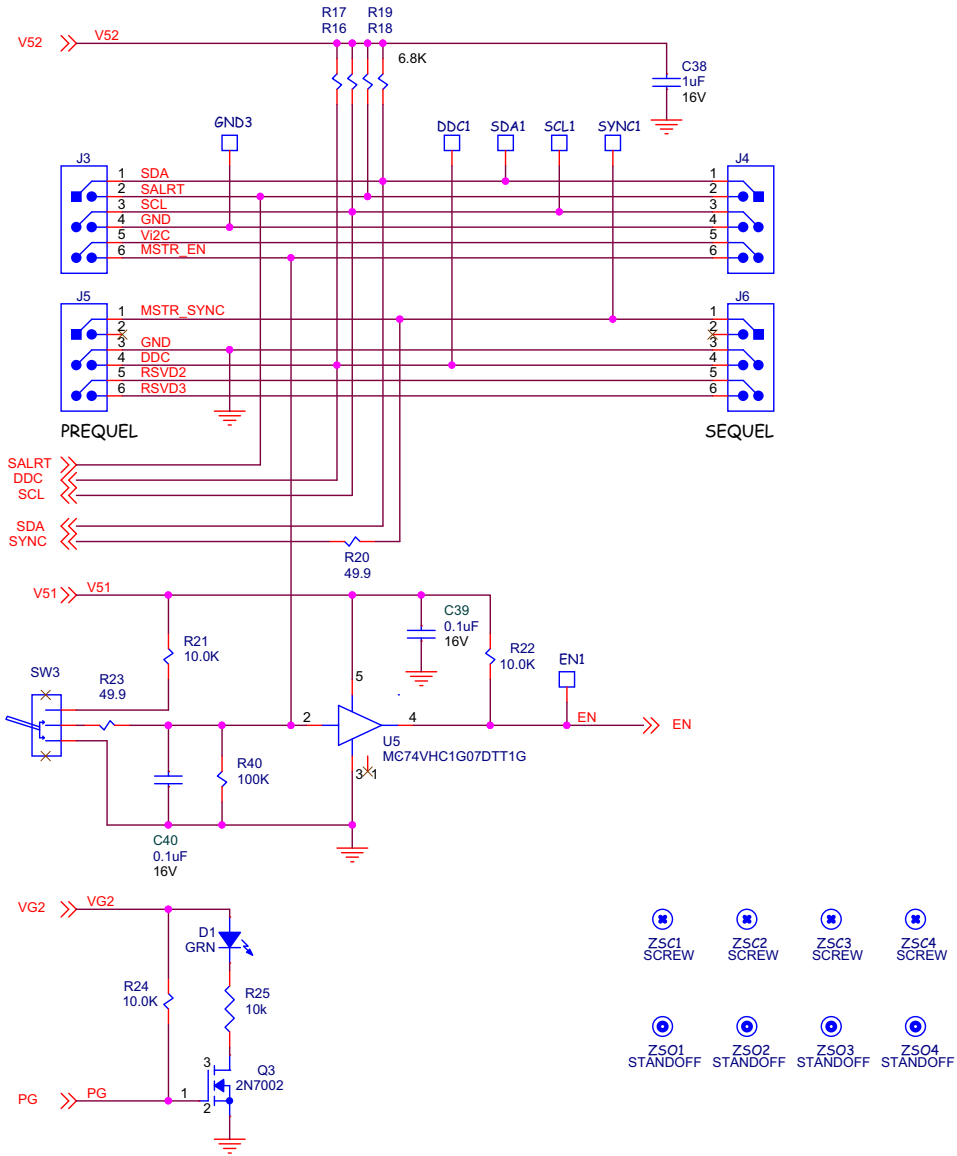

Figure 6. Schematic - I<sup>2</sup>C, Enable, PG

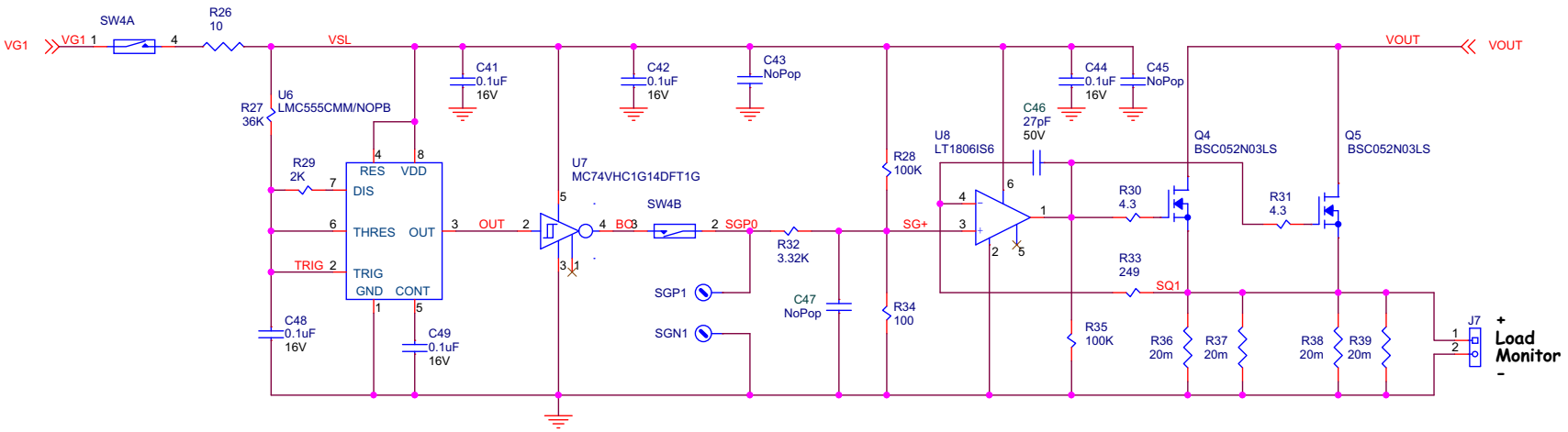

Figure 7. Schematic - Dynamic Load

### 3.2 Bill of Materials

Qty	Reference Designator	Description	Manufacturer	Manufacturer Part
4	C1, C2, C12, C13	CAP, SMD, 0805, 10µF, 16V, 10%, X6S, ROHS	TDK	C2012X6S1C106K085AC
4	C30, C34, C52, C53	CAP, SMD, 1206, 150µF, 6.3V, 20%, X5R, ROHS	Murata	GRM31CR60J157ME11L
2	C8, C19	CAP, SMD, 0402, 1000pF, 50V, 5%, C0G, ROHS	Venkel	C0402C0G500-102JNE
7	C39, C40, C41, C42, C44, C48, C49	CAP, SMD, 0402, 0.1µF, 16V, 10%, X7R, ROHS	Murata	GRM155R71C104JA88D
5	C4, C16, C23, C31, C38	CAP, SMD, 0402, 1.0µF, 16V, 10%, X5R, ROHS	TDK	C1005X5R1C105K050BC
2	C9, C20	CAP, SMD, 0402, 100pF, 50V, 5%, NP0, ROHS	AVX	04023A101FAT2A
2	C6, C17	CAP, SMD, 0402, 0.22µF, 10V, 10%, X5R, ROHS	Venkel	C0402X5R100-224KNE
1	C46	CAP, SMD, 0402, 27pF, 50V, 5%, NP0, ROHS	Murata	GRM36COG270J050AQ
6	C5, C10, C11, C15, C21, C22	CAP, SMD, 0402, 4.7µF, 10V, 10%, X5R, ROHS	TDK	C1005X5R1A475K050BC
6	C35, C36, C37, C54, C55, C56	CAP, SMD, 0805, 47µF, 6.3V, 20%, X5R, ROHS	Kemet	C0805C476M9PACTU
6	C3, C14, C26, C27, C57, C58	CAP, SMD, 1206, 22µF, 25V, 10%, X5R, ROHS	Murata	GRM31CR61E226KE15L
2	C7, C18	CAP, SMD, 0402, 0.47µF, 6.3V, 10%, X7R, ROHS	Taiyo Yuden	JMK105B7474KVHF
2	C24, C25	CAP, SMD, 8x12, 180µF, 16V, 20%, 16mΩ, ALUM.ELEC., ROHS	Nippon Chemi-Con	APXA160ARA181MJC0G
4	C28, C32, C50, C51	CAP, SMD, D, 470µF, 2.5V, 20%, 3mΩ, POLY.AL.EL., ROHS	Panasonic	EEF-GX0E471L
2	L1, L2	COIL-PWR INDUCTOR, SMD, 10.7x7, 200nH, 10%, 61A, 18mΩ, ROHS	Eaton/Bussmann	FP1110V2-R200-R
1	D1	LED, SMD, 0805, GREEN/CLEAR, 2.2V, 20mA, 574nm, 45mcd, ROHS	Lumex	SML-LX0805SUGC-TR
2	U1, U3	IC-DIGITAL DC/DC CONTROLLER, 24P, QFN, ROHS	Renesas	ISL68300IRAZ
2	U2, U4	TRANSISTOR-MOS, DUAL N-CHNL, 8P, WDFN, 25V, 20A/35A, ROHS	On Semiconductor	FDPC8016S
1	U8	IC-OP AMP, R/R, SMD, 6P, TSOT23, 325MHz, 85mA, ROHS	Linear Technology	LT1806IS6#TRMPBF
1	U5	IC-NON-INVERTING BUFFER, SMD, 5P, TSOT23-5, ROHS	On Semiconductor	MC74VHC1G07DTT1G
1	U7	IC-INVERTER, SCHMITT TRIGGER, SMD, 5P, SC-70-5, ROHS	On Semiconductor	MC74VHC1G14DFT1G
1	U6	IC-TIMER/OSCILLATOR, 2.1MHz, SMD, 8P, SOIC, ROHS	Texas Instruments	TLC555CDR
2	Q1, Q2	TRANSISTOR-NPN, SMD, SOT-416, 200mA, 40V, 300mW, ROHS	On Semiconductor	MMBT3904TT1G
1	Q3	TRANSISTOR, N-CHANNEL, 3LD, SOT-23, 60V, 115mA, ROHS	Diodes, Inc.	2N7002-7-F
2	Q4, Q5	TRANSIST-MOS, N-CHANNEL, 30V, 57A, SMD, 8P, PG-TDSON-8, ROHS	Infineon Technology	BSC052N03LS
4	R36, R37, R38, R39	RES-AEC-Q200, CURR.SENSE, SMD, 2512, 0.02Ω, 3W, 1%, TF, ROHS	Bourns	CRA2512-FZ-R020ELF

Qty	Reference Designator	Description	Manufacturer	Manufacturer Part
2	R2, R7	RES, SMD, 0402, 2.2Ω, 1/16W, 1%, TF, ROHS	Yageo	RC0402FR-072R2L
2	R30, R31	RES, SMD, 0402, 4.3Ω, 1/16W, 5%, TF, ROHS	Vishay/Dale	CRCW04024R30FKED
1	R13	RES, SMD, 0402, 0Ω, 1/16W, 5%, TF, ROHS	Venkel	CR0402-16W-00T
1	R34	RES, SMD, 0402, 100Ω, 1/16W, 1%, TF, ROHS	Venkel	CR0402-16W-1000FT
3	R21, R22, R24	RES, SMD, 0402, 10k, 1/16W, 1%, TF, ROHS	Panasonic	ERJ-2RKF1002X
3	R28, R35, R40	RES, SMD, 0402, 100k, 1/16W, 1%, TF, ROHS	Panasonic	ERJ2RKF1003
1	R29	RES, SMD, 0402, 2k, 1/16W, 1%, TF, ROHS	Panasonic	ERJ-2RKF2001
1	R33	RES, SMD, 0402, 249Ω, 1/16W, 1%, TF, ROHS	Panasonic	ERJ-2RKF2490
1	R10	RES, SMD, 0402, 31.6kΩ, 1/16W, 5%, TF, ROHS	Venkel	CR0402-16W-3162FT
1	R32	RES, SMD, 0402, 3.32k, 1/16W, 1%, TF, ROHS	Yageo	RC0402FR-073K32L
1	R27	RES, SMD, 0402, 36k, 1/16W, 1%, TF, ROHS	Yageo	RC0402FR-0736KL
1	R3	RES, SMD, 0402, 41.2k, 1/16W, 5%, TF, ROHS	Vishay/Dale	CRCW040241K2FKED
1	R5	RES, SMD, 0402, 22.1k, 1/16W, 1%, TF, ROHS	Panasonic	ERJ-2RKF2212V
2	R20, R23	RES, SMD, 0402, 49.9Ω, 1/16W, 1%, TF, ROHS	Panasonic	ERJ-2RKF49R9X
1	R8	RES, SMD, 0402, 59k, 1/16W, 1%, TF, ROHS	Panasonic	ERJ-2RKF5902
4	R16, R17, R18, R19	RES, SMD, 0402, 6.8k, 1/16W, 1%, TF, ROHS	Panasonic	ERJ-2RKF6801X
1	R3	RES, SMD, 0402, 8.25k, 1/16W, 1%, TF, ROHS	Panasonic	ERJ-2RKF8251
1	R26	RES, SMD, 0603, 10Ω, 1/10W, 1%, TF, ROHS	KOA	RK73H1JT10R0F
1	R15	RES, SMD, 0603, 100Ω, 1/10W, 1%, TF, ROHS	Venkel	CR0603-10W-1000FT
1	R25	RES, SMD, 0603, 10kΩ, 1/10W, 1%, TF, ROHS	Venkel	CR0603-10W-1002FT
2	R1, R6	RES, SMD, 0603, 3.01k, 1/10W, 1%, TF, ROHS	Rohm	MCR03EZPF3011
1	SW3	SWITCH-TOGGLE, SPDT, TH, 5P, 28V, 0.4VA, ON-ON, ROHS	NKK	G12AP
1	SW4	SWITCH-SLIDE, SMD, 7.06mm, 2POS, SPST, 25mA, 24V, ROHS	C&K Components	SDA02H1SBD
2	GND3, VOUT3	HARDWARE, 65A PCB WIRE LUG, TH/SMD, 8.5x3.5, 6-14AWG, ROHS	International Hydraulics Inc	B6A-PCB-SS
2	VIN1, GND1	CONN-JACK, BANANA-SS-SDRLESS, VERTICAL, 0.53Length, ROHS	Johnson Components	108-0740-001
1	GND_O1	CONN-DBL TURRET, TH, 0.218x0.078 PCB MNT, TIN/BRASS, ROHS	Keystone	1502-1
1	SGP1	CONN-MINI TEST PT, VERTICAL, RED, ROHS	Keystone	5000
1	SGN1	CONN-MINI TEST PT, VERTICAL, BLK, ROHS	Keystone	5001
2	J1, J7	CONN-HEADER, 1x2, RETENTIVE, 2.54mm, 0.230x0.120, ROHS	Berg/fci	69190-202HLF
1	J2	CONN-HEADER, 1x3, BRKAWY 1x36, 2.54mm, TAIL LENGTH.145"	3M	929647-09-36-I-1X3
2	J4, J6	CONN-SOCKET STRIP, TH, 2x3, 2.54mm, TIN, R/A, ROHS	Samtec	SSQ-103-02-T-D-RA
2	J3, J5	CONN-HEADER, 2x3, BRKAWY, 2.54mm, TIN, R/A, ROHS	Samtec	TSW-103-08-T-D-RA
4	ZSC1, ZSC2, ZSC3, ZSC4	SCREW, 4-40x1/4in, PHILLIPS, PANHEAD, STAINLESS, ROHS	Building Fasteners	PMSSS 440 0025 PH
4	ZSO1, ZSO2, ZSO3, ZSO4	STANDOFF, 4-40x3/4in, F/F, HEX, ALUMINUM, 0.25 OD, ROHS	Keystone	2204

Qty	Reference Designator	Description	Manufacturer	Manufacturer Part
0	C43, C45, C47, C59, C60	DO NOT POPULATE		

### 3.3 ISL68300EVAL3Z Board Layout

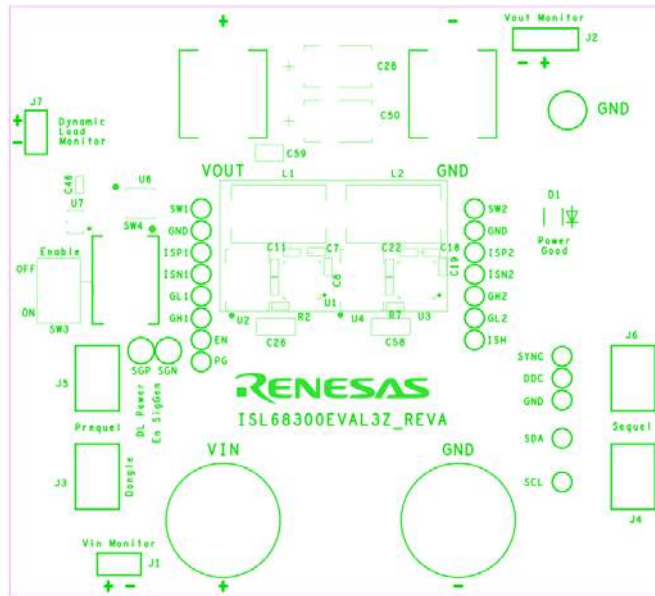

Figure 8. PCB - Top Silk Screen

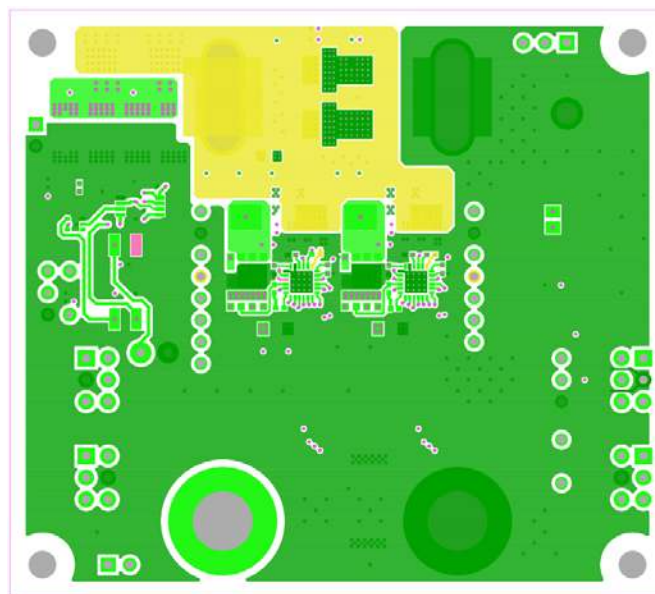

Figure 9. PCB - Top Layer

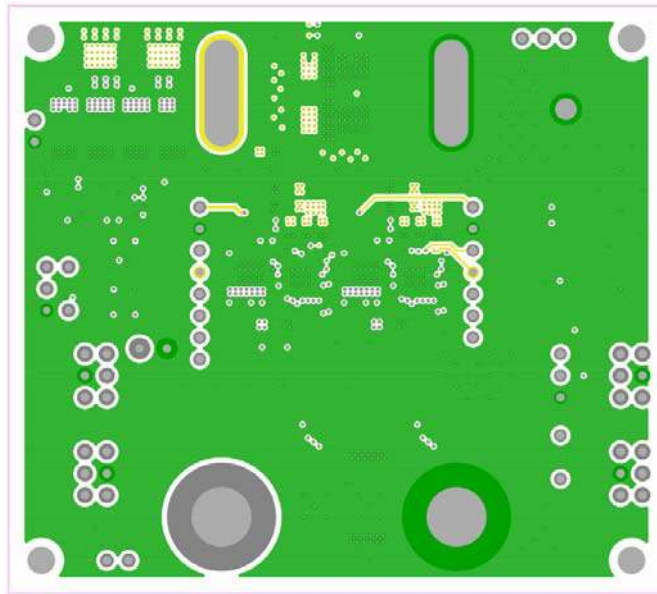

Figure 10. PCB - Inner Layer - Layer 2 (Top View)

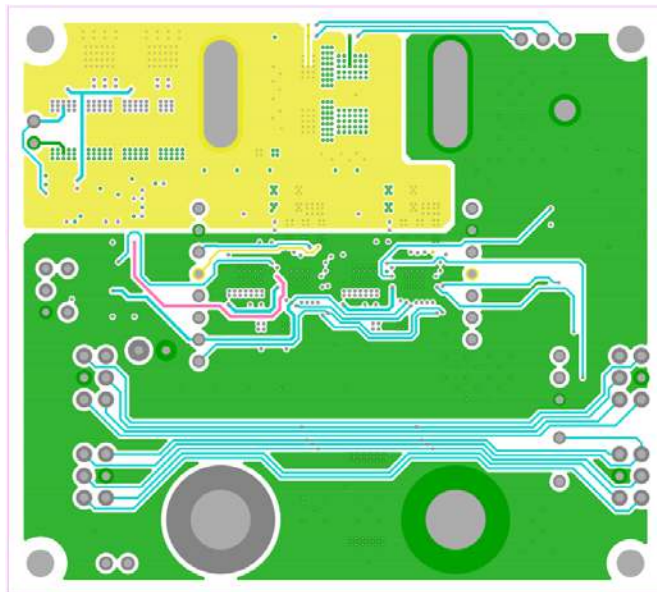

Figure 11. PCB - Inner Layer - Layer 3 (Top View)

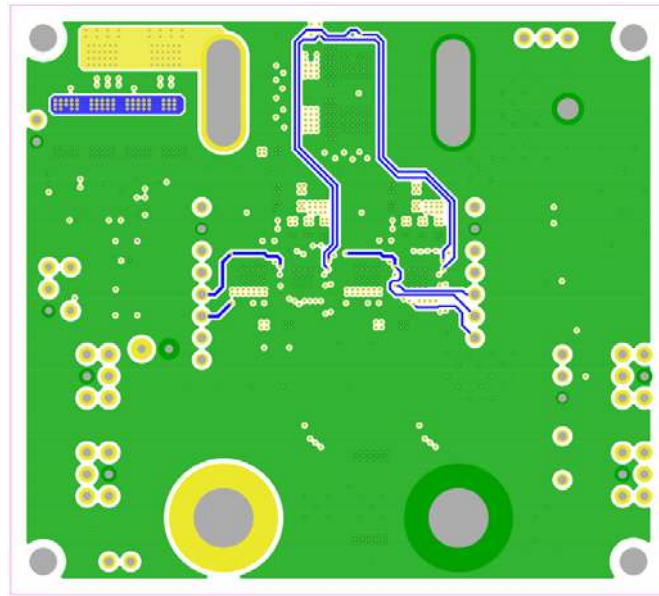

Figure 12. PCB - Inner Layer - Layer 4 (Top View)

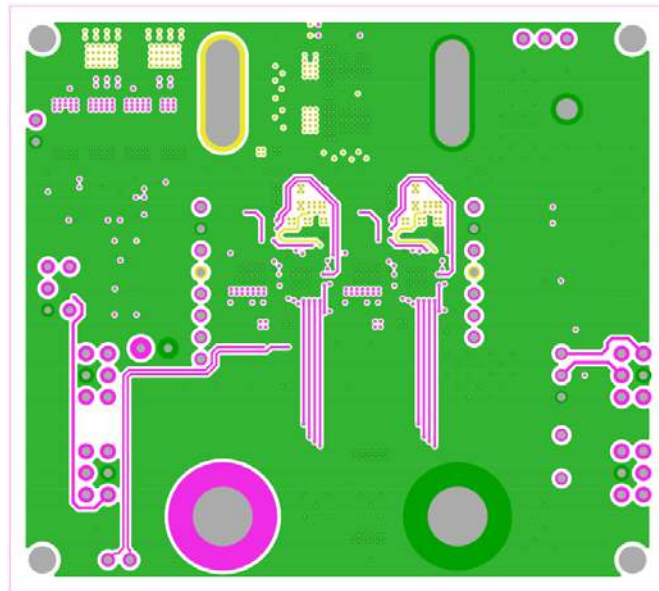

Figure 13. PCB - Inner Layer - Layer 5 (Top View)



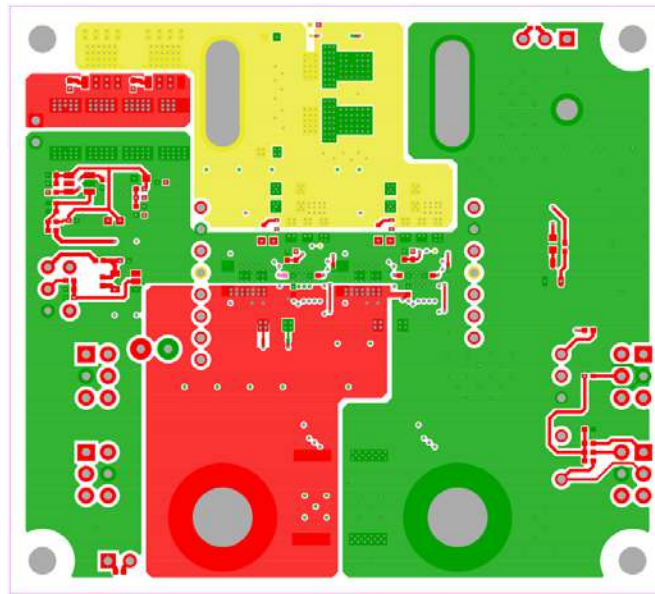

Figure 14. PCB - Bottom Layer (Top View)

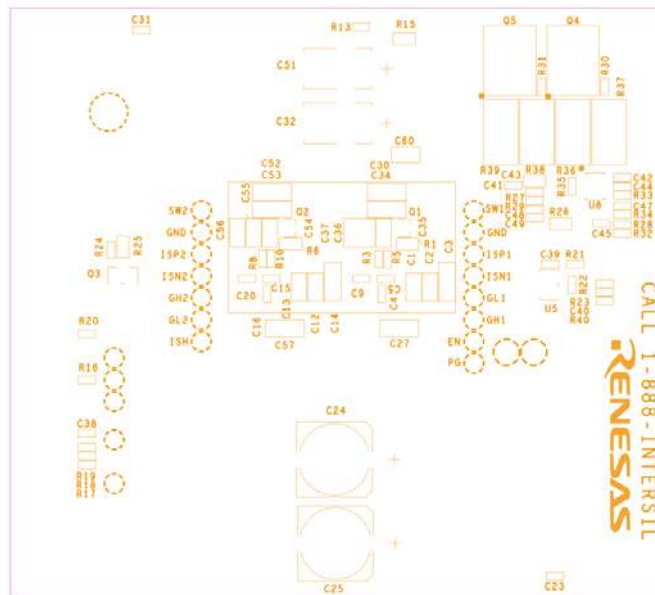

Figure 15. PCB - Bottom Silk Screen



## 4. Typical Performance Curves

Unless noted:  $V_{IN} = 12V$ ,  $T_A = +25^\circ C$

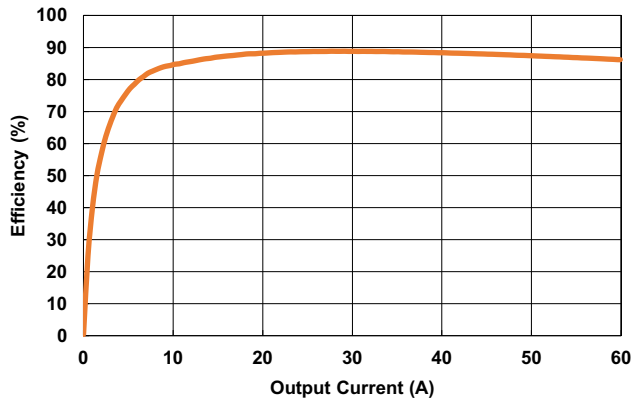

Figure 16. Efficiency

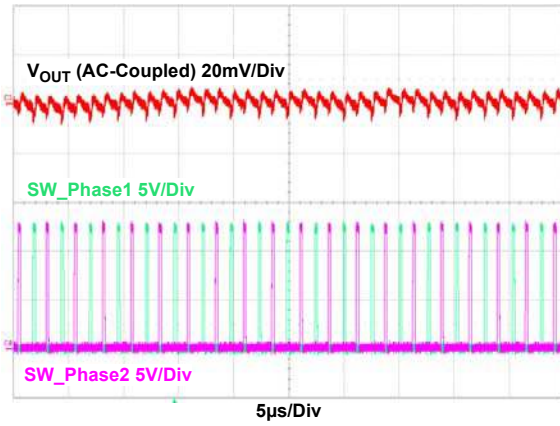

Figure 17. Output Voltage Ripple at Full Load

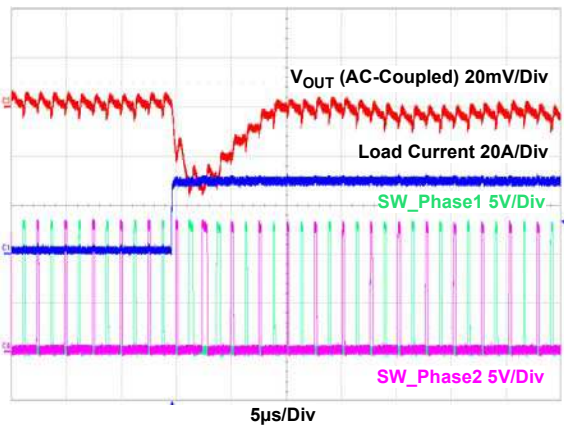

Figure 18. Load Transient Waveforms

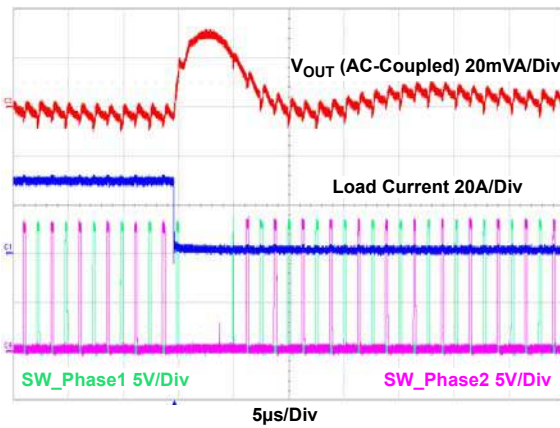

Figure 19. Load Transient Waveforms

## 5. Configuration files

Sample configuration files for the ISL68300 in the ISL68300EVAL3Z. Copy and paste (from STORE\_CONTROL to ### End User Store) to a text editor and save it as Confile\_file\_name.txt. The # symbol is used for a comment line.

- Configuration file for the master device (Address = 0x62)

```

STORE_CONTROL      0x21
STORE_CONTROL      0x11
STORE_CONTROL      0x12
# -----Start of User Settings-----
VOUT_COMMAND       0x2000    # 1 V
VOUT_MAX           0x2666    # 1.2 V
VOUT_MARGIN_HIGH   0x219A    # 1.05 V
VOUT_MARGIN_LOW    0x1E66    # 0.95 V
FREQUENCY_SWITCH   0xFB20    # 400 kHz
IOUT_CAL_GAIN      0xAAE1    # 0.36 mV/A
VOUT_OV_FAULT_LIMIT 0x2333    # 1.1 V
VOUT_OV_WARN_LIMIT 0x228F    # 1.08 V
VOUT_UV_WARN_LIMIT 0x1B33    # 0.85 V
VOUT_UV_FAULT_LIMIT 0x199A    # 0.8 V
IOUT_OC_FAULT_LIMIT 0xE320    # 50 A
IOUT_OC_WARN_LIMIT 0xE2D0    # 45 A
IOUT_UC_FAULT_LIMIT 0xE4E0    # -50 A
POWER_GOOD_ON      0x1CCD    # 0.9 V
ISENSE_CONFIG      0x2902
USER_CONFIG        0x0C45
DDC_CONFIG         0x0001
ASCR_ADVANCED      0x21A9
INDUCTOR           0xA333    # 0.2 µH
ASCR_CONFIG        0x3B450226
TRACK_CONFIG       0x00
DDC_GROUP          0x00202020
IOUT_AVG_OC_FAULT_LIMIT 0xE280    # 40 A
IOUT_AVG_UC_FAULT_LIMIT 0xE580    # -40 A
# -----End of User Settings-----
# -----Store Setup - Do Not Modify-----
STORE_CONTROL      0x13
### End User Store

```

- Configuration file for the master device (Address = 0x63)

```

STORE_CONTROL      0x21
STORE_CONTROL      0x11
STORE_CONTROL      0x12
# -----Start of User Settings-----
ON_OFF_CONFIG      0x17
VOUT_COMMAND       0x2000    # 1 V
VOUT_CAL_OFFSET    0x0000    # 0 V
VOUT_MAX           0x2666    # 1.2 V
VOUT_MARGIN_HIGH   0x219A    # 1.05 V
VOUT_MARGIN_LOW    0x1E66    # 0.95 V
MAX_DUTY           0xEB20    # 100 %
FREQUENCY_SWITCH   0xFB20    # 400 kHz
INTERLEAVE         0x0008
IOUT_CAL_GAIN      0xAAE1    # 0.36 mV/A
IOUT_CAL_OFFSET    0x0000    # 0 A
VOUT_OV_FAULT_LIMIT 0x2333    # 1.1 V
VOUT_OV_FAULT_RESPONSE 0x80
VOUT_OV_WARN_LIMIT 0x228F    # 1.08 V
VOUT_UV_WARN_LIMIT 0x1B33    # 0.85 V
VOUT_UV_FAULT_LIMIT 0x199A    # 0.8 V
VOUT_UV_FAULT_RESPONSE 0x80
IOUT_OC_FAULT_LIMIT 0xE320    # 50 A
IOUT_OC_WARN_LIMIT 0xE2D0    # 45 A
IOUT_UC_FAULT_LIMIT 0xE4E0    # -50 A
OT_FAULT_LIMIT     0xEBE8    # 125 °C
OT_FAULT_RESPONSE  0x80
OT_WARN_LIMIT      0xEB70    # 110 °C
UT_WARN_LIMIT      0xDC40    # -30 °C
UT_FAULT_LIMIT     0xE530    # -45 °C
UT_FAULT_RESPONSE  0x80
VIN_OV_FAULT_LIMIT 0xDA00    # 16 V
VIN_OV_FAULT_RESPONSE 0x80
VIN_OV_WARN_LIMIT  0xD3E0    # 15.5 V
VIN_UV_WARN_LIMIT  0xCB80    # 7 V
VIN_UV_FAULT_LIMIT 0xCB40    # 6.5 V
VIN_UV_FAULT_RESPONSE 0x80
POWER_GOOD_ON      0x1CCD    # 0.9 V

```

---

```

TON_RISE          0xCA80    # 5 ms
TOFF_FALL         0xCA80    # 5 ms
ISENSE_CONFIG     0x2902
USER_CONFIG       0x0C4A
DDC_CONFIG        0x2001
POWER_GOOD_DELAY  0xBA00    # 1 ms
ASCR_ADVANCED     0x21A9
INDUCTOR          0xA333    # 0.2 μH
OVUV_CONFIG       0x02     # 2 null
TEMPCO_CONFIG     0xA7
ASCR_CONFIG       0x3B450226
SEQUENCE          0x0000
TRACK_CONFIG      0x00
DDC_GROUP         0x00202020
MFR_IOUT_OC_FAULT_RESPONSE  0x80
MFR_IOUT_UC_FAULT_RESPONSE  0x80
IOUT_AVG_OC_FAULT_LIMIT    0xE280    # 40 A
IOUT_AVG_UC_FAULT_LIMIT    0xE580    # -40 A
# -----End of User Settings-----
# -----Store Setup - Do Not Modify-----
STORE_CONTROL     0x13
### End User Store

```

## 6. Revision History

Rev.	Date	Description
0.00	Jul 12, 2018	Initial release

ISL68300EVAL3Z

