

**SPECIFICATION**

**1. MECHANICAL**

Manual measurement probe for SWH-2WAY(MM8930-2620) to measure RF side performance.

B>

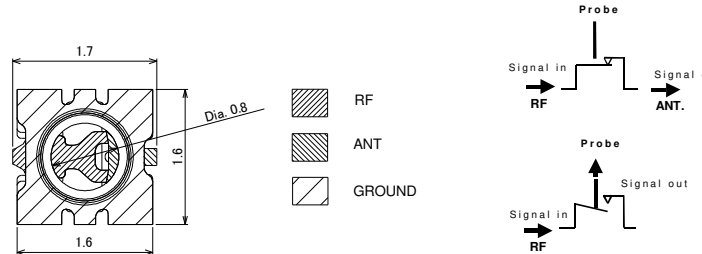

A>

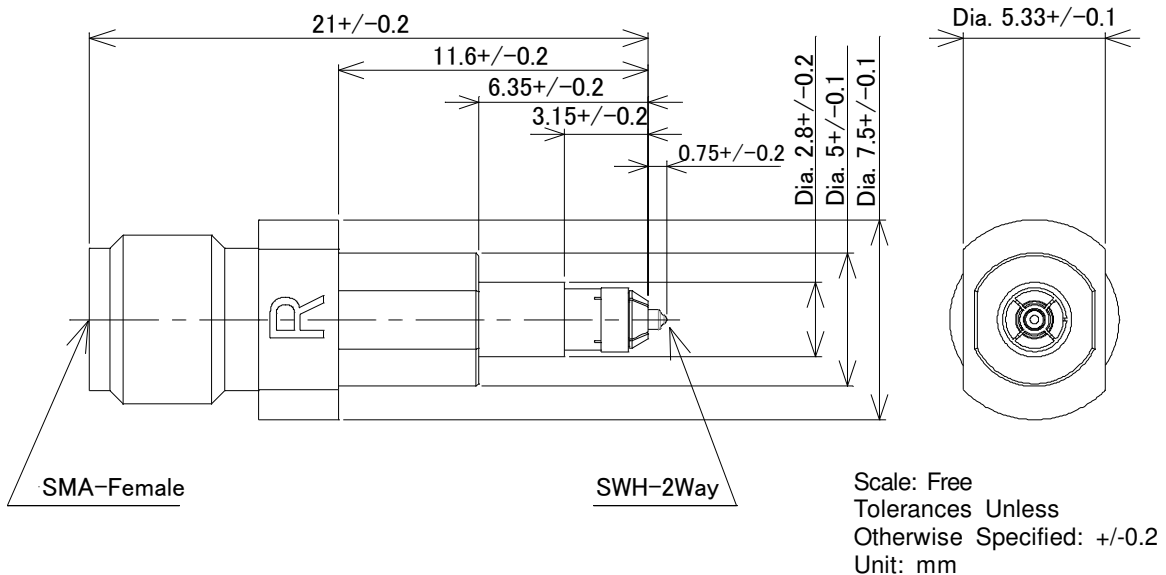

Figure.1 Construction

**2. RATING:**

Item	Specification
Voltage Rating	30V r.m.s. maximum
Nominal Frequency Range	DC to 6GHz
Nominal Impedance	50Ω
Temperature Rating	-40°C to +85°C
Insulation Resistance	500 MΩ minimum
Withstanding Voltage	No evidence of breakdown
Initial Contact Resistance (without conductor resistance)	70 m Ω max.
B> Voltage Standing Wave Ratio (V.S.W.R.)	Meet the requirements of following spec. 1.6 max.(DC ~ 3GHz) 1.9 max.(3GHz ~ 6GHz)
B> Insertion loss	0.5dB max. (DC ~ 3GHz) 0.8dB max. (3GHz ~ 6GHz)
B> Durability	2K cycles
B> Engage and disengage force. (PROBE side only)	a. Engagement 30N maximum b. Disengagement 5N minimum 23N maximum