

THIS DRAWING IS UNPUBLISHED. RELEASED FOR PUBLICATION  
 © COPYRIGHT - TE Connectivity Ltd. ALL RIGHTS RESERVED.

REVISIONS				
P	LTR	DESCRIPTION	DATE	DWN APVD
N		REVISED PER 0720-0937-96	31MAY96	DKS MJS
N1		REVISED PER ECO-17-018398	20DEC2017	RS DR

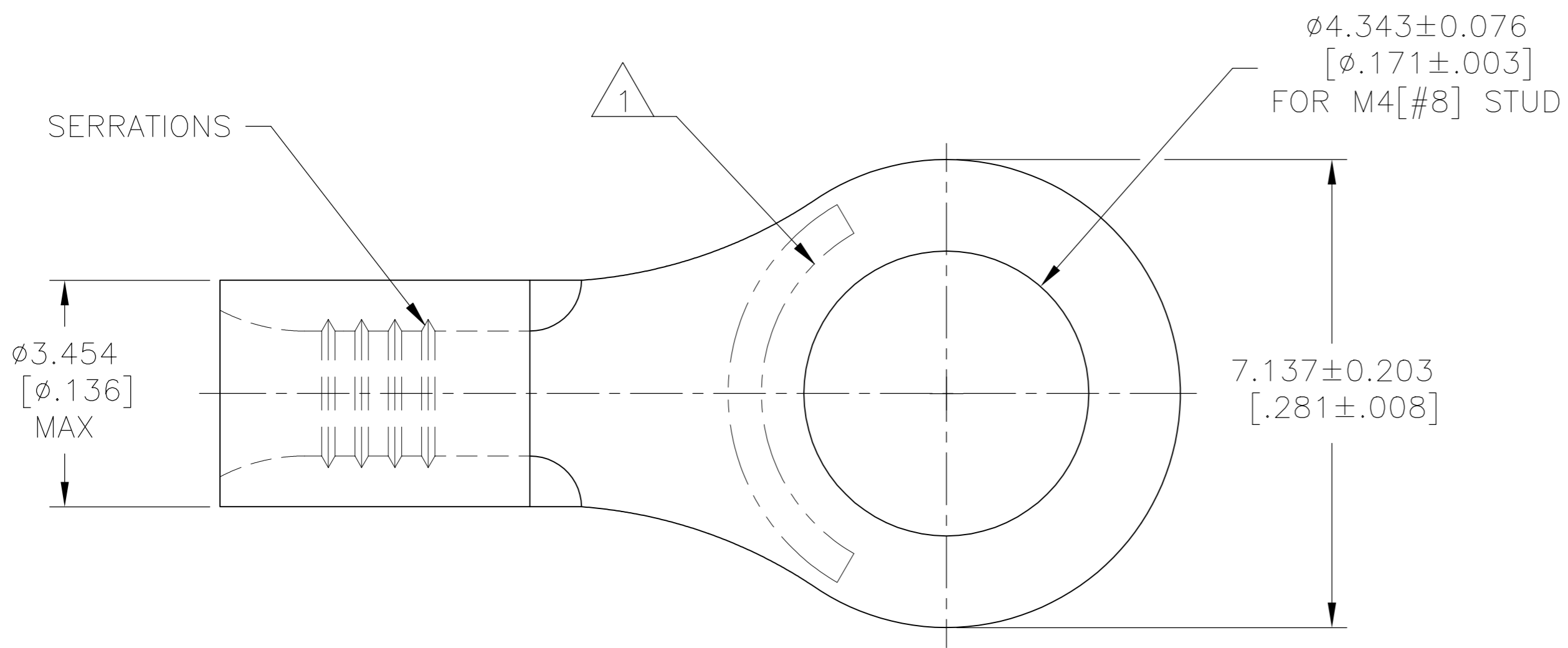

<b>AMP</b> WIRE RANGE	E13288 Listed
22-16 AWG STRANDED	22-16 AWG STRANDED

- 1 STAMP AMP 22-18\* APPROX AS SHOWN  
22-16 TERMINALS ARE STAMPED 22-18 IN  
ACCORDANCE WITH MILITARY SPEC SAE AS7928  
COMMERCIAL WIRE SIZE IS 22-16
- 2 CLEANED, UNPLATED
- 3 TIN PLATED 0.00254[.000100]  
MIN THK PER ASTM B545

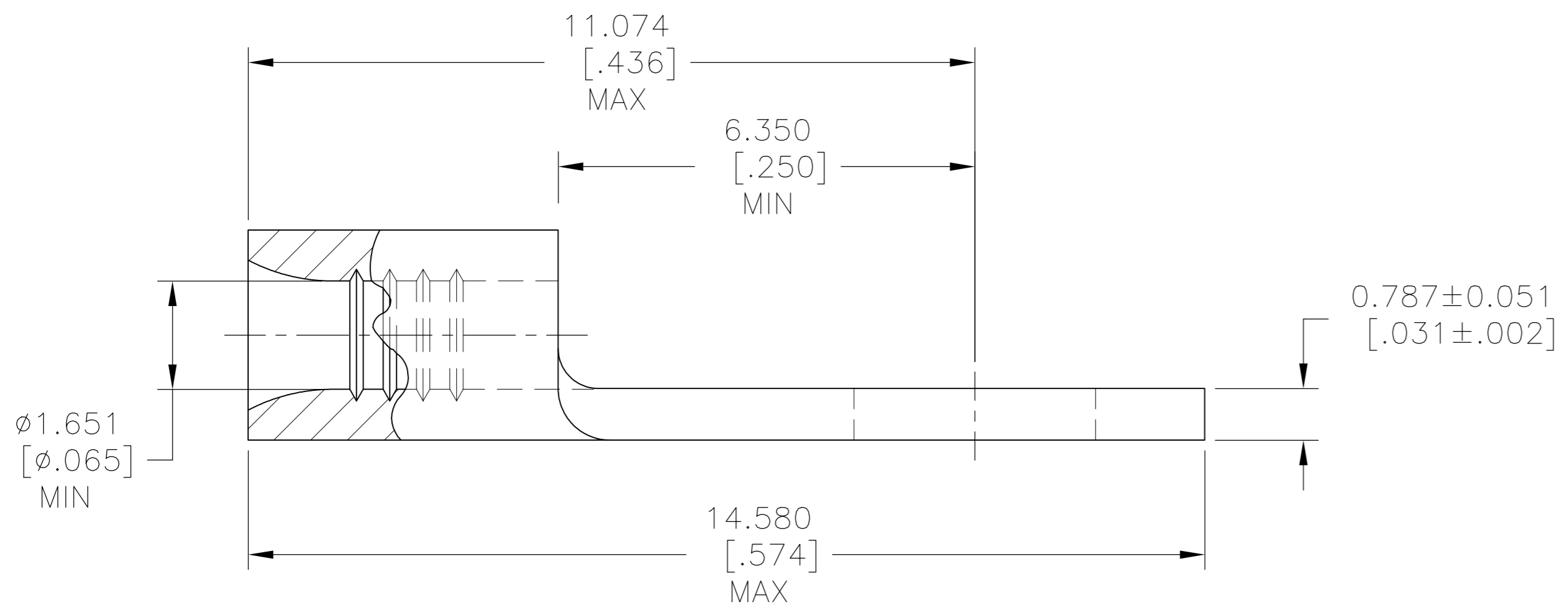

PRELIMINARY	2	1000	LOOSE PIECE	31265-1
	3	1000	LOOSE PIECE	31265
	FINISH	QUANTITY	PACKAGE TYPE	PART NO.

AMP INCORPORATED  
CUSTOMER SERVICE SYSTEMS

THIS DRAWING IS A CONTROLLED DOCUMENT.

DWN	TA BRINKMAN	2-3-93
CHK	DA PATTERSON	2-3-93
APVD	DE MILLER	2-3-93
PRODUCT SPEC	UL486 A-B	
APPLICATION SPEC		
WEIGHT	-	



TERMINAL, RING TONGUE,  
BUDGET, 22-16 AWG

FOR ADDITIONAL PRODUCT INFORMATION OR COPIES OF DRAWINGS AND TECHNICAL DOCUMENTS	PRODUCT INFORMATION CENTER 1-800-522-6752
FOR APPLICATION TOOLING INFORMATION	TOOLING ASSISTANCE CENTER 1-800-722-1111
FOR ORDER ENTRY	1-800-526-5142

MAX RECOMMENDED OPERATING TEMPERATURE: 170°C [338°F] MAX
VOLTAGE RATING: NOT APPLICABLE
WIRE CROSS SECTIONAL AREA RANGE, 0.26-1.65mm²[509-3,260] CIR MILS SOLID OR STRANDED

DIMENSIONS: mm [INCHES]	TOLERANCES UNLESS OTHERWISE SPECIFIED:
	0 PLC ± - 1 PLC ± - 2 PLC ± - 3 PLC ± 0.127[.005] 4 PLC ± - ANGLES ± -
MATERIAL COPPER PER ASTM B-152 ANNEALED	FINISH SEE TABLE

NAME	TERMINAL, RING TONGUE, BUDGET, 22-16 AWG		
SIZE	CAGE CODE	DRAWING NO	RESTRICTED TO
A3	00779	C-31265	-
CUSTOMER DRAWING			SCALE 10:1 SHEET 1 OF 1 REV N1