

MPU-6500
Product Specification
Revision 1.3

TABLE OF CONTENTS

1	INTRODUCTION.....	5
1.1	PURPOSE AND SCOPE.....	5
1.2	PRODUCT OVERVIEW.....	5
1.3	APPLICATIONS.....	5
2	FEATURES.....	6
2.1	GYROSCOPE FEATURES.....	6
2.2	ACCELEROMETER FEATURES.....	6
2.3	ADDITIONAL FEATURES.....	6
2.4	MOTIONPROCESSING®.....	6
3	ELECTRICAL CHARACTERISTICS.....	7
3.1	GYROSCOPE SPECIFICATIONS.....	7
3.2	ACCELEROMETER SPECIFICATIONS.....	8
3.3	ELECTRICAL SPECIFICATIONS.....	9
3.4	I ² C TIMING CHARACTERIZATION.....	13
3.5	SPI TIMING CHARACTERIZATION.....	14
3.6	ABSOLUTE MAXIMUM RATINGS.....	16
4	APPLICATIONS INFORMATION.....	17
4.1	PIN OUT DIAGRAM AND SIGNAL DESCRIPTION.....	17
4.2	TYPICAL OPERATING CIRCUIT.....	18
4.3	BILL OF MATERIALS FOR EXTERNAL COMPONENTS.....	18
4.4	BLOCK DIAGRAM.....	19
4.5	OVERVIEW.....	19
4.6	THREE-AXIS MEMS GYROSCOPE WITH 16-BIT ADCs AND SIGNAL CONDITIONING.....	20
4.7	THREE-AXIS MEMS ACCELEROMETER WITH 16-BIT ADCs AND SIGNAL CONDITIONING.....	20
4.8	DIGITAL MOTIONPROCESSOR®.....	20
4.9	PRIMARY I ² C AND SPI SERIAL COMMUNICATIONS INTERFACES.....	20
4.10	AUXILIARY I ² C SERIAL INTERFACE.....	22
4.11	SELF-TEST.....	23
4.12	CLOCKING.....	23
4.13	SENSOR DATA REGISTERS.....	24
4.14	FIFO.....	24
4.15	INTERRUPTS.....	24
4.16	DIGITAL-OUTPUT TEMPERATURE SENSOR.....	24
4.17	BIAS AND LDOs.....	24

4.18	CHARGE PUMP	25
4.19	STANDARD POWER MODES	25
5	PROGRAMMABLE INTERRUPTS.....	26
5.1	WAKE-ON-MOTION INTERRUPT	27
6	DIGITAL INTERFACE	28
6.1	I ² C AND SPI SERIAL INTERFACES	28
6.2	I ² C INTERFACE	28
6.3	I ² C COMMUNICATIONS PROTOCOL.....	28
6.4	I ² C TERMS	31
6.5	SPI INTERFACE	32
7	SERIAL INTERFACE CONSIDERATIONS.....	33
7.1	MPU-6500 SUPPORTED INTERFACES.....	33
8	ASSEMBLY	34
8.1	ORIENTATION OF AXES	34
8.2	PACKAGE DIMENSIONS	35
9	PART NUMBER PACKAGE MARKING	36
10	RELIABILITY	37
10.1	QUALIFICATION TEST POLICY	37
10.2	QUALIFICATION TEST PLAN	37
11	REFERENCE	38
12	REVISION HISTORY	39

Table of Figures

Figure 1. I²C Bus Timing Diagram..... 13
 Figure 2. SPI Bus Timing Diagram 14
 Figure 3. Pin out Diagram for MPU-6500 3.0x3.0x0.9mm QFN..... 17
 Figure 4. MPU-6500 QFN Application Schematic. (a) I²C operation, (b) SPI operation. 18
 Figure 5. MPU-6500 Block Diagram..... 19
 Figure 6. MPU-6500 Solution Using I²C Interface 21
 Figure 7. MPU-6500 Solution Using SPI Interface 22
 Figure 8. Wake-on-Motion Interrupt Configuration..... 27
 Figure 9. START and STOP Conditions 28
 Figure 10. Acknowledge on the I²C Bus..... 29
 Figure 11. Complete I²C Data Transfer 30
 Figure 12. Typical SPI Master / Slave Configuration..... 32
 Figure 13. I/O Levels and Connections 33
 Figure 14. Orientation of Axes of Sensitivity and Polarity of Rotation..... 34

Table of Tables

Table 1. Gyroscope Specifications 7
 Table 2. Accelerometer Specifications 8
 Table 3. D.C. Electrical Characteristics..... 9
 Table 4. A.C. Electrical Characteristics..... 11
 Table 5. Other Electrical Specifications 12
 Table 6. I²C Timing Characteristics 13
 Table 7. SPI Timing Characteristics..... 14
 Table 8. fCLK = 20 MHz 15
 Table 9. Absolute Maximum Ratings 16
 Table 10. Signal Descriptions..... 17
 Table 11. Bill of Materials 18
 Table 12. Standard Power Modes for MPU-6500..... 25
 Table 13. Table of Interrupt Sources 26
 Table 14. Serial Interface..... 28
 Table 15. I²C Terms..... 31
 Table 16. Accelerated Life Tests 37
 Table 17. Device Component Level Tests 37

1 INTRODUCTION

1.1 PURPOSE AND SCOPE

This document is a product specification, providing a description, specifications, and design related information on the MPU-6500™ MotionTracking device. The device is housed in a small 3x3x0.90mm QFN package.

Specifications are subject to change without notice. For references to register map and descriptions of individual registers, please refer to the MPU-6500 Register Map and Register Descriptions document.

1.2 PRODUCT OVERVIEW

The MPU-6500 is a 6-axis MotionTracking device that combines a 3-axis gyroscope, 3-axis accelerometer, and a Digital MotionProcessor® (DMP®) all in a small 3x3x0.9mm package. It also features a 512-byte FIFO that can lower the traffic on the serial bus interface, and reduce power consumption by allowing the system processor to burst read sensor data and then go into a low-power mode. With its dedicated I²C sensor bus, the MPU-6500 directly accepts inputs from external I²C devices. MPU-6500, with its 6-axis integration, on-chip DMP, and run-time calibration firmware, enables manufacturers to eliminate the costly and complex selection, qualification, and system level integration of discrete devices, guaranteeing optimal motion performance for consumers. MPU-6500 is also designed to interface with multiple non-inertial digital sensors, such as pressure sensors, on its auxiliary I²C port.

The gyroscope has a programmable full-scale range of ± 250 , ± 500 , ± 1000 , and ± 2000 degrees/sec and very low rate noise at 0.01 dps/VHz. The accelerometer has a user-programmable accelerometer full-scale range of $\pm 2g$, $\pm 4g$, $\pm 8g$, and $\pm 16g$. Factory-calibrated initial sensitivity of both sensors reduces production-line calibration requirements.

Other industry-leading features include on-chip 16-bit ADCs, programmable digital filters, a precision clock with 1% drift from -40°C to 85°C, an embedded temperature sensor, and programmable interrupts. The device features I²C and SPI serial interfaces, a VDD operating range of 1.71 to 3.6V, and a separate digital IO supply, VDDIO from 1.71V to 3.6V.

Communication with all registers of the device is performed using either I²C at 400kHz or SPI at 1MHz. For applications requiring faster communications, the sensor and interrupt registers may be read using SPI at 20MHz.

By leveraging its patented and volume-proven CMOS-MEMS fabrication platform, which integrates MEMS wafers with companion CMOS electronics through wafer-level bonding, InvenSense has driven the package size down to a footprint and thickness of 3x3x0.90mm (24-pin QFN), to provide a very small yet high performance low cost package. The device provides high robustness by supporting 10,000g shock reliability.

1.3 APPLICATIONS

- *TouchAnywhere*™ technology (for “no touch” UI Application Control/Navigation)
- *MotionCommand*™ technology (for Gesture Short-cuts)
- Motion-enabled game and application framework
- Location based services, points of interest, and dead reckoning
- Handset and portable gaming
- Motion-based game controllers
- 3D remote controls for Internet connected DTVs and set top boxes, 3D mice
- Wearable sensors for health, fitness and sports

2 FEATURES

2.1 GYROSCOPE FEATURES

The triple-axis MEMS gyroscope in the MPU-6500 includes a wide range of features:

- Digital-output X-, Y-, and Z-axis angular rate sensors (gyroscopes) with a user-programmable full-scale range of ± 250 , ± 500 , ± 1000 , and $\pm 2000^\circ/\text{sec}$ and integrated 16-bit ADCs
- Digitally-programmable low-pass filter
- Gyroscope operating current: 3.2mA
- Factory calibrated sensitivity scale factor
- Self-test

2.2 ACCELEROMETER FEATURES

The triple-axis MEMS accelerometer in MPU-6500 includes a wide range of features:

- Digital-output X-, Y-, and Z-axis accelerometer with a programmable full scale range of $\pm 2g$, $\pm 4g$, $\pm 8g$ and $\pm 16g$ and integrated 16-bit ADCs
- Accelerometer normal operating current: 450 μ A
- Low power accelerometer mode current: 6.37 μ A at 0.98Hz, 17.75 μ A at 31.25Hz
- User-programmable interrupts
- Wake-on-motion interrupt for low power operation of applications processor
- Self-test

2.3 ADDITIONAL FEATURES

The MPU-6500 includes the following additional features:

- Auxiliary master I²C bus for reading data from external sensors (e.g. magnetometer)
- 3.4mA operating current when all 6 motion sensing axes are active
- VDD supply voltage range of 1.8 – 3.3V \pm 5%
- VDDIO reference voltage of 1.8 – 3.3V \pm 5% for auxiliary I²C devices
- Smallest and thinnest QFN package for portable devices: 3x3x0.9mm
- Minimal cross-axis sensitivity between the accelerometer and gyroscope axes
- 512 byte FIFO buffer enables the applications processor to read the data in bursts
- Digital-output temperature sensor
- User-programmable digital filters for gyroscope, accelerometer, and temp sensor
- 10,000 *g* shock tolerant
- 400kHz Fast Mode I²C for communicating with all registers
- 1MHz SPI serial interface for communicating with all registers
- 20MHz SPI serial interface for reading sensor and interrupt registers
- MEMS structure hermetically sealed and bonded at wafer level
- RoHS and Green compliant

2.4 MOTIONPROCESSING[®]

- Internal Digital MotionProcessing[®] (DMP) engine supports advanced MotionProcessing[®] and low power functions such as gesture recognition using programmable interrupts
- In addition to the angular rate, this device optionally outputs the angular position (angle).
- Low-power pedometer functionality allows the host processor to sleep while the DMP maintains the step count.

3 ELECTRICAL CHARACTERISTICS

3.1 GYROSCOPE SPECIFICATIONS

Typical Operating Circuit of section 4.2, VDD = 1.8V, VDDIO = 1.8V, T_A=25°C, unless otherwise noted.

PARAMETER	CONDITIONS	MIN	TYP	MAX	UNITS	NOTES
GYROSCOPE SENSITIVITY						
Full-Scale Range	FS_SEL=0		±250		°/s	3
	FS_SEL=1		±500		°/s	3
	FS_SEL=2		±1000		°/s	3
	FS_SEL=3		±2000		°/s	3
Gyroscope ADC Word Length			16		bits	3
Sensitivity Scale Factor	FS_SEL=0		131		LSB/(°/s)	3
	FS_SEL=1		65.5		LSB/(°/s)	3
	FS_SEL=2		32.8		LSB/(°/s)	3
	FS_SEL=3		16.4		LSB/(°/s)	3
Sensitivity Scale Factor Tolerance	25°C		±3		%	2
Sensitivity Scale Factor Variation Over Temperature	-40°C to +85°C		±4		%	1
Nonlinearity	Best fit straight line; 25°C		±0.1		%	1
Cross-Axis Sensitivity			±2		%	1
ZERO-RATE OUTPUT (ZRO)						
Initial ZRO Tolerance	25°C		±5		°/s	2
ZRO Variation Over Temperature	-40°C to +85°C		±0.24		°/s/°C	1
GYROSCOPE NOISE PERFORMANCE (FS_SEL=0)						
Total RMS Noise	DLPFCFG=2 (92 Hz)		0.1		°/s-rms	2
Rate Noise Spectral Density			0.01		°/s/√Hz	4
GYROSCOPE MECHANICAL FREQUENCIES		25	27	29	KHz	2
LOW PASS FILTER RESPONSE	Programmable Range	5		250	Hz	3
GYROSCOPE START-UP TIME	From Sleep mode		35		ms	1
OUTPUT DATA RATE	Programmable, Normal (Filtered) mode	4		8000	Hz	1

Table 1. Gyroscope Specifications

Notes:

1. Derived from validation or characterization of parts, not guaranteed in production.
2. Tested in production.
3. Guaranteed by design.
4. Calculated from Total RMS Noise.

Please refer to the following document for information on Self-Test: MPU-6500 Accelerometer and Gyroscope Self-Test Implementation; AN-MPU-6500A-02

3.2 ACCELEROMETER SPECIFICATIONS

Typical Operating Circuit of section 4.2, VDD = 1.8V, VDDIO = 1.8V, T_A=25°C, unless otherwise noted.

PARAMETER	CONDITIONS	MIN	TYP	MAX	UNITS	NOTES
ACCELEROMETER SENSITIVITY						
Full-Scale Range	AFS_SEL=0		±2		g	3
	AFS_SEL=1		±4		g	3
	AFS_SEL=2		±8		g	3
	AFS_SEL=3		±16		g	3
ADC Word Length	Output in two's complement format		16		bits	3
Sensitivity Scale Factor	AFS_SEL=0		16,384		LSB/g	3
	AFS_SEL=1		8,192		LSB/g	3
	AFS_SEL=2		4,096		LSB/g	3
	AFS_SEL=3		2,048		LSB/g	3
Initial Tolerance	Component-level		±3		%	2
Sensitivity Change vs. Temperature	-40°C to +85°C AFS_SEL=0 Component-level		±0.026		%/°C	1
Nonlinearity	Best Fit Straight Line		±0.5		%	1
Cross-Axis Sensitivity			±2		%	1
ZERO-G OUTPUT						
Initial Tolerance	Component-level, all axes		±60		mg	2
Zero-G Level Change vs. Temperature	-40°C to +85°C, Board-level	X and Y axes	±0.64		mg/°C	1
		Z axis	±1		mg/°C	1
NOISE PERFORMANCE						
Power Spectral Density	Low noise mode		300		µg/√Hz	4
LOW PASS FILTER RESPONSE	Programmable Range	5		260	Hz	3
INTELLIGENCE FUNCTION INCREMENT			4		mg/LSB	3
ACCELEROMETER STARTUP TIME	From Sleep mode		20		ms	1
	From Cold Start, 1ms V _{DD} ramp		30		ms	1
OUTPUT DATA RATE	Low power (duty-cycled)	0.24		500	Hz	1
	Duty-cycled, over temp		±15		%	
	Low noise (active)	4		4000	Hz	

Table 2. Accelerometer Specifications

Notes:

1. Derived from validation or characterization of parts, not guaranteed in production.
2. Tested in production.
3. Guaranteed by design.
4. Calculated from Total RMS Noise.

Please refer to the following document for information on Self-Test: MPU-6500 Accelerometer and Gyroscope Self-Test Implementation; AN-MPU-6500A-02

3.3 ELECTRICAL SPECIFICATIONS

3.3.1 D.C. Electrical Characteristics

Typical Operating Circuit of section 4.2, VDD = 1.8V, VDDIO = 1.8V, T_A=25°C, unless otherwise noted.

PARAMETER	CONDITIONS	MIN	TYP	MAX	Units	Notes
SUPPLY VOLTAGES						
VDD		1.71	1.8	3.45	V	1
VDDIO		1.71	1.8	3.45	V	1
SUPPLY CURRENTS						
Normal Mode	6-axis		3.4		mA	1
	3-axis Gyroscope		3.2		mA	1
	3-Axis Accelerometer, 4kHz ODR		450		μA	1
Accelerometer Low Power Mode	0.98 Hz update rate		7.27		μA	1,2
	31.25 Hz update rate		18.65		μA	1,2
Standby Mode			1.6		mA	1
Full-Chip Sleep Mode			6		μA	1
TEMPERATURE RANGE						
Specified Temperature Range	Performance parameters are not applicable beyond Specified Temperature Range	-40		+85	°C	1

Table 3. D.C. Electrical Characteristics

Notes:

1. Derived from validation or characterization of parts, not guaranteed in production.
2. Accelerometer Low Power Mode supports the following output data rates (ODRs): 0.24, 0.49, 0.98, 1.95, 3.91, 7.81, 15.63, 31.25, 62.50, 125, 250, 500Hz. Supply current for any update rate can be calculated as: Supply Current in μA = 6.9 + Update Rate * 0.376

3.3.2 A.C. Electrical Characteristics

 Typical Operating Circuit of section 4.2, VDD = 1.8V, VDDIO = 1.8V, T_A=25°C, unless otherwise noted.

Parameter	Conditions	MIN	TYP	MAX	Units	NOTES
SUPPLIES						
Supply Ramp Time	Monotonic ramp. Ramp rate is 10% to 90% of the final value	0.1		100	ms	1
TEMPERATURE SENSOR						
Operating Range	Ambient	-40		85	°C	1
Sensitivity	Untrimmed		333.87		LSB/°C	
Room Temp Offset	21°C		0		LSB	
Power-On RESET						
Supply Ramp Time (T _{RAMP})	Valid power-on RESET	0.01	20	100	ms	1
Start-up time for register read/write	From power-up		11	100	ms	1
I²C ADDRESS	AD0 = 0 AD0 = 1		1101000 1101001			
DIGITAL INPUTS (FSYNC, AD0, SCLK, SDI, CS)						
V _{IH} , High Level Input Voltage		0.7*VDDIO			V	1
V _{IL} , Low Level Input Voltage				0.3*VDDIO	V	
C _i , Input Capacitance			< 10		pF	
DIGITAL OUTPUT (SDO, INT)						
V _{OH} , High Level Output Voltage	R _{LOAD} =1MΩ;	0.9*VDDIO			V	1
V _{OL1} , LOW-Level Output Voltage	R _{LOAD} =1MΩ;			0.1*VDDIO	V	
V _{OLINT1} , INT Low-Level Output Voltage	OPEN=1, 0.3mA sink Current			0.1	V	
Output Leakage Current	OPEN=1		100		nA	
t _{INT} , INT Pulse Width	LATCH_INT_EN=0		50		μs	
I2C I/O (SCL, SDA)						
V _{IL} , LOW Level Input Voltage		-0.5V		0.3*VDDIO	V	1
V _{IH} , HIGH-Level Input Voltage		0.7*VDDIO		VDDIO + 0.5V	V	
V _{hys} , Hysteresis			0.1*VDDIO		V	
V _{OL} , LOW-Level Output Voltage	3mA sink current	0		0.4	V	
I _{OL} , LOW-Level Output Current	V _{OL} =0.4V V _{OL} =0.6V		3 6		mA mA	
Output Leakage Current			100		nA	
t _{of} , Output Fall Time from V _{IHmax} to V _{ILmax}	C _b bus capacitance in pf	20+0.1C _b		250	ns	
AUXILLIARY I/O (AUX_CL, AUX_DA)						
V _{IL} , LOW-Level Input Voltage		-0.5V		0.3*VDDIO	V	1
V _{IH} , HIGH-Level Input Voltage		0.7* VDDIO		VDDIO + 0.5V	V	
V _{hys} , Hysteresis			0.1* VDDIO		V	
V _{OL1} , LOW-Level Output Voltage	VDDIO > 2V; 1mA sink current	0		0.4	V	
V _{OL3} , LOW-Level Output Voltage	VDDIO < 2V; 1mA sink current	0		0.2* VDDIO	V	

Parameter	Conditions	MIN	TYP	MAX	Units	NOTES
I_{OL} , LOW-Level Output Current	$V_{OL} = 0.4V$		3		mA	
	$V_{OL} = 0.6V$		6		mA	
Output Leakage Current			100		nA	
t_{of} , Output Fall Time from V_{IHmax} to V_{ILmax}	C_b bus capacitance in pF	$20+0.1C_b$		250	ns	
INTERNAL CLOCK SOURCE						
Sample Rate	Fchoice=0,1,2 SMPLRT_DIV=0		32		kHz	2
	Fchoice=3; DLPFCFG=0 or 7 SMPLRT_DIV=0		8		kHz	2
	Fchoice=3; DLPFCFG=1,2,3,4,5,6; SMPLRT_DIV=0		1		kHz	2
Clock Frequency Initial Tolerance	CLK_SEL=0, 6; 25°C	-2		+2	%	1
	CLK_SEL=1,2,3,4,5; 25°C	-1		+1	%	1
Frequency Variation over Temperature	CLK_SEL=0,6	-10		+10	%	1
	CLK_SEL=1,2,3,4,5		±1		%	1

Table 4. A.C. Electrical Characteristics

Notes:

1. Derived from validation or characterization of parts, not guaranteed in production.
2. Guaranteed by design.

3.3.3 Other Electrical Specifications

Typical Operating Circuit of section 4.2, VDD = 1.8V, VDDIO = 1.8V, T_A=25°C, unless otherwise noted.

PARAMETER	CONDITIONS	MIN	TYP	MAX	Units	Notes
SERIAL INTERFACE						
SPI Operating Frequency, All Registers Read/Write	Low Speed Characterization		100 ±10%		kHz	1
	High Speed Characterization		1 ±10%		MHz	1
SPI Operating Frequency, Sensor and Interrupt Registers Read Only			20 ±10%		MHz	1
I ² C Operating Frequency	All registers, Fast-mode			400	kHz	1
	All registers, Standard-mode			100	kHz	1

Table 5. Other Electrical Specifications

Notes:

1. Derived from validation or characterization of parts, not guaranteed in production.

3.4 I²C TIMING CHARACTERIZATION

Typical Operating Circuit of section 4.2, VDD = 1.8V, VDDIO = 1.8V, T_A=25°C, unless otherwise noted.

Parameters	Conditions	Min	Typical	Max	Units	Notes
I²C TIMING	I²C FAST-MODE					1
f _{SCL} , SCL Clock Frequency				400	kHz	2
t _{HD:STA} , (Repeated) START Condition Hold Time		0.6			μs	2
t _{LOW} , SCL Low Period		1.3			μs	2
t _{HIGH} , SCL High Period		0.6			μs	2
t _{SU:STA} , Repeated START Condition Setup Time		0.6			μs	2
t _{HD:DAT} , SDA Data Hold Time		0			μs	2
t _{SU:DAT} , SDA Data Setup Time		100			ns	2
t _r , SDA and SCL Rise Time	C _b bus cap. from 10 to 400pF	20+0.1C _b		300	ns	2
t _f , SDA and SCL Fall Time	C _b bus cap. from 10 to 400pF	20+0.1C _b		300	ns	2
t _{SU:STO} , STOP Condition Setup Time		0.6			μs	2
t _{BUF} , Bus Free Time Between STOP and START Condition		1.3			μs	2
C _b , Capacitive Load for each Bus Line			< 400		pF	2
t _{VD:DAT} , Data Valid Time				0.9	μs	2
t _{VD:ACK} , Data Valid Acknowledge Time				0.9	μs	2

Table 6. I²C Timing Characteristics

Notes:

1. Timing Characteristics apply to both Primary and Auxiliary I²C Bus
2. Based on characterization of 5 parts over temperature and voltage as mounted on evaluation board or in sockets

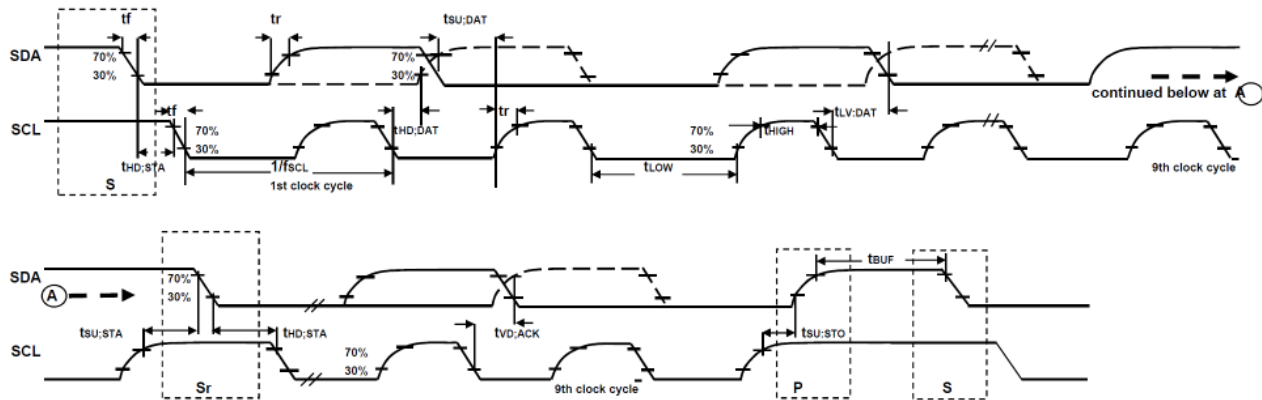

Figure 1. I²C Bus Timing Diagram

3.5 SPI TIMING CHARACTERIZATION

Typical Operating Circuit of section 4.2, VDD = 1.8V, VDDIO = 1.8V, T_A=25°C, unless otherwise noted.

Parameters	Conditions	Min	Typical	Max	Units	Notes
SPI TIMING						
f _{SCLK} , SCLK Clock Frequency				1	MHz	1
t _{LOW} , SCLK Low Period		400			ns	1
t _{HIGH} , SCLK High Period		400			ns	1
t _{SU,CS} , CS Setup Time		8			ns	1
t _{HD,CS} , CS Hold Time		500			ns	1
t _{SU,SDI} , SDI Setup Time		11			ns	1
t _{HD,SDI} , SDI Hold Time		7			ns	1
t _{VD,SDO} , SDO Valid Time	C _{load} = 20pF			100	ns	1
t _{HD,SDO} , SDO Hold Time	C _{load} = 20pF	4			ns	1
t _{DIS,SDO} , SDO Output Disable Time				50	ns	1

Table 7. SPI Timing Characteristics

Notes:

1. Based on characterization of 5 parts over temperature and voltage as mounted on evaluation board or in sockets

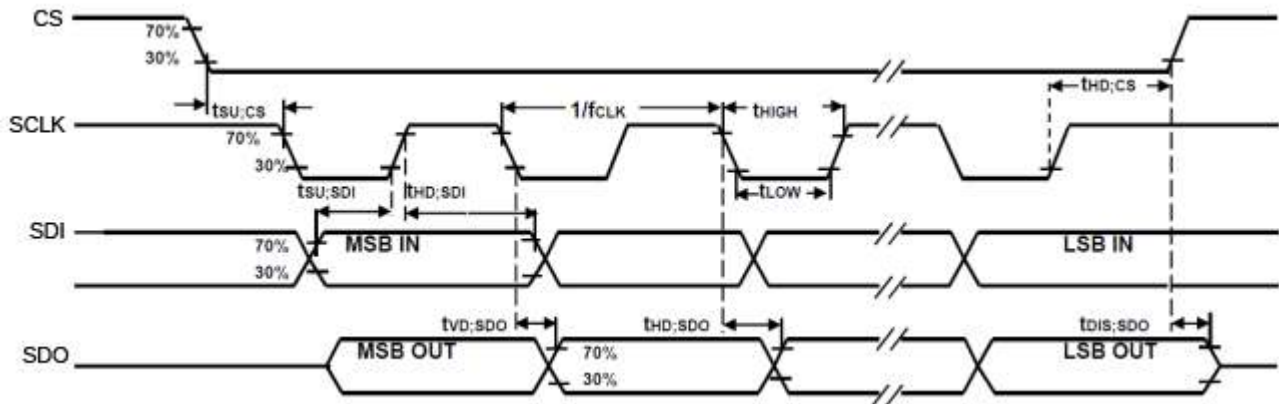

Figure 2. SPI Bus Timing Diagram

3.5.1 fSCLK = 20 MHz

Parameters	Conditions	Min	Typical	Max	Units	Notes
SPI TIMING						
f _{SCLK} , SCLK Clock Frequency		0.9		20	MHz	1
t _{LOW} , SCLK Low Period		-		-	ns	
t _{HIGH} , SCLK High Period		-		-	ns	
t _{SU,CS} , CS Setup Time		1			ns	1
t _{HD,CS} , CS Hold Time		1			ns	1
t _{SU,SDI} , SDI Setup Time		0			ns	1
t _{HD,SDI} , SDI Hold Time		1			ns	1
t _{VD,SDO} , SDO Valid Time	C _{load} = 20pF		25		ns	1
t _{DIS,SDO} , SDO Output Disable Time				25	ns	1

Table 8. fCLK = 20 MHz
Notes:

1. Based on characterization of 5 parts over temperature and voltage as mounted on evaluation board or in sockets

3.6 ABSOLUTE MAXIMUM RATINGS

Stress above those listed as “Absolute Maximum Ratings” may cause permanent damage to the device. These are stress ratings only and functional operation of the device at these conditions is not implied. Exposure to the absolute maximum ratings conditions for extended periods may affect device reliability.

Parameter	Rating
Supply Voltage, VDD	-0.5V to +4V
Supply Voltage, VDDIO	-0.5V to +4V
REGOUT	-0.5V to 2V
Input Voltage Level (AUX_DA, AD0, FSYNC, INT, SCL, SDA)	-0.5V to VDD + 0.5V
Acceleration (Any Axis, unpowered)	10,000g for 0.2ms
Operating Temperature Range	-40°C to +105°C
Storage Temperature Range	-40°C to +125°C
Electrostatic Discharge (ESD) Protection	2kV (HBM); 250V (MM)
Latch-up	JEDEC Class II (2), 125°C, ±100mA

Table 9. Absolute Maximum Ratings

4 APPLICATIONS INFORMATION

4.1 PIN OUT DIAGRAM AND SIGNAL DESCRIPTION

Pin Number	Pin Name	Pin Description
7	AUX_CL	I ² C Master serial clock, for connecting to external sensors
8	VDDIO	Digital I/O supply voltage
9	AD0 / SDO	I ² C Slave Address LSB (AD0); SPI serial data output (SDO)
10	REGOUT	Regulator filter capacitor connection
11	FSYNC	Frame synchronization digital input. Connect to GND if unused.
12	INT	Interrupt digital output (totem pole or open-drain) Note: The Interrupt line should be connected to a pin on the Application Processor (AP) that can bring the AP out of suspend mode.
13	VDD	Power supply voltage and Digital I/O supply voltage
18	GND	Power supply ground
19	RESV	Reserved. Do not connect.
20	RESV	Reserved. Connect to GND.
21	AUX_DA	I ² C master serial data, for connecting to external sensors
22	nCS	Chip select (SPI mode only)
23	SCL / SCLK	I ² C serial clock (SCL); SPI serial clock (SCLK)
24	SDA / SDI	I ² C serial data (SDA); SPI serial data input (SDI)
1 – 6, 14 - 17	NC	No Connect pins. Do not connect.

Table 10. Signal Descriptions

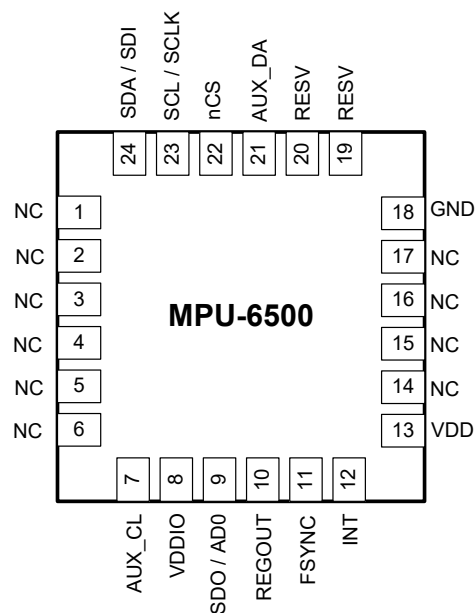

Figure 3. Pin out Diagram for MPU-6500 3.0x3.0x0.9mm QFN

4.2 TYPICAL OPERATING CIRCUIT

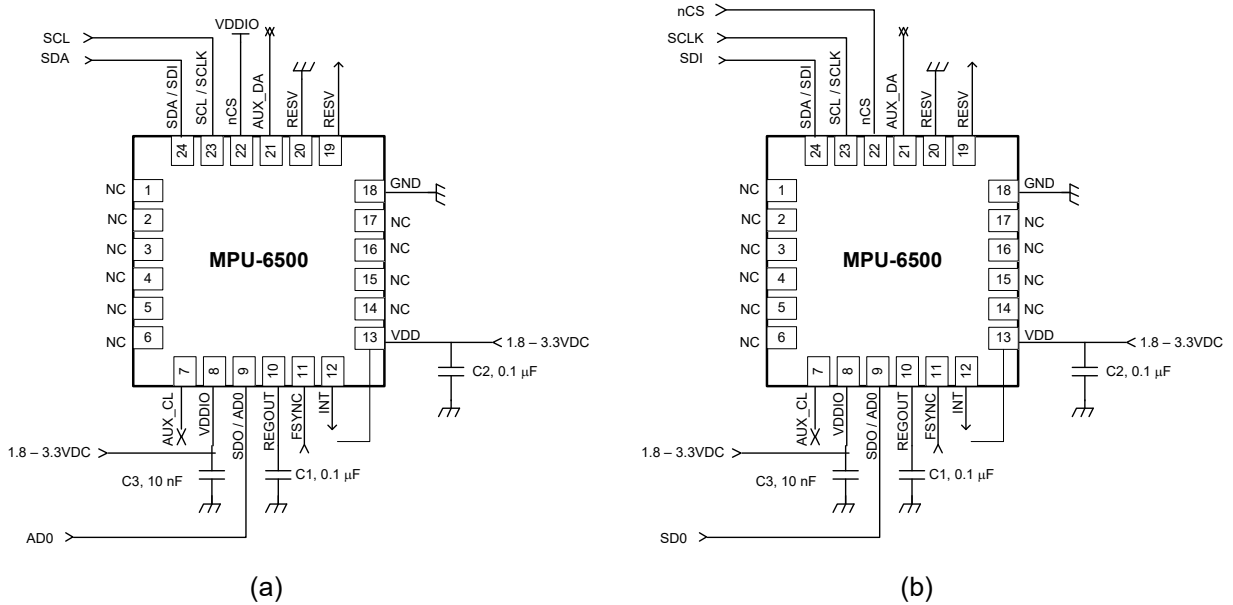

Figure 4. MPU-6500 QFN Application Schematic. (a) I²C operation, (b) SPI operation.

4.3 BILL OF MATERIALS FOR EXTERNAL COMPONENTS

Component	Label	Specification	Quantity
Regulator Filter Capacitor	C1	Ceramic, X7R, 0.1μF ±10%, 2V	1
VDD Bypass Capacitor	C2	Ceramic, X7R, 0.1μF ±10%, 4V	1
VDDIO Bypass Capacitor	C3	Ceramic, X7R, 10nF ±10%, 4V	1

Table 11. Bill of Materials

4.4 BLOCK DIAGRAM

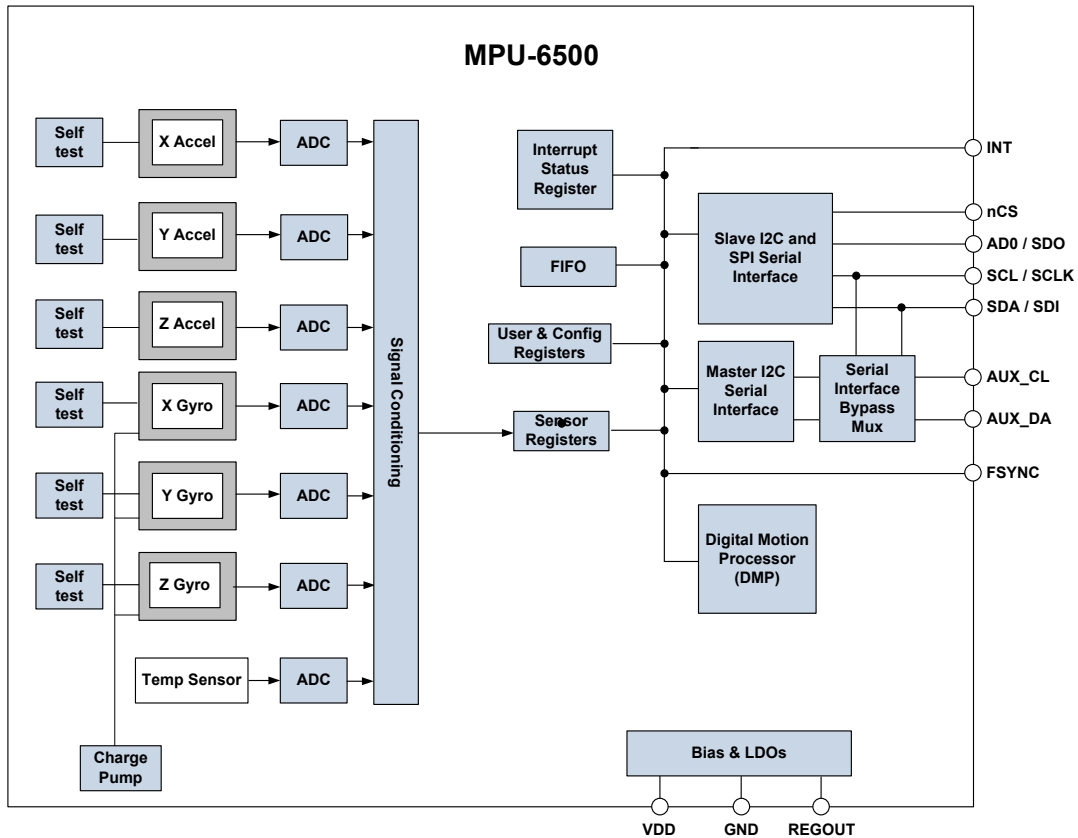

Figure 5. MPU-6500 Block Diagram

Note: The Interrupt line should be connected to a pin on the Application Processor (AP) that can bring the AP out of suspend mode.

4.5 OVERVIEW

The MPU-6500 is comprised of the following key blocks and functions:

- Three-axis MEMS rate gyroscope sensor with 16-bit ADCs and signal conditioning
- Three-axis MEMS accelerometer sensor with 16-bit ADCs and signal conditioning
- Digital MotionProcessor® (DMP) engine
- Primary I²C and SPI serial communications interfaces
- Auxiliary I²C serial interface
- Self-Test
- Clocking
- Sensor Data Registers
- FIFO
- Interrupts
- Digital-Output Temperature Sensor
- Bias and LDOs
- Charge Pump
- Standard Power Modes

4.6 THREE-AXIS MEMS GYROSCOPE WITH 16-BIT ADCS AND SIGNAL CONDITIONING

The MPU-6500 consists of three independent vibratory MEMS rate gyroscopes, which detect rotation about the X-, Y-, and Z- Axes. When the gyros are rotated about any of the sense axes, the Coriolis Effect causes a vibration that is detected by a capacitive pickoff. The resulting signal is amplified, demodulated, and filtered to produce a voltage that is proportional to the angular rate. This voltage is digitized using individual on-chip 16-bit Analog-to-Digital Converters (ADCs) to sample each axis. The full-scale range of the gyro sensors may be digitally programmed to ± 250 , ± 500 , ± 1000 , or ± 2000 degrees per second (dps). The ADC sample rate is programmable from 8,000 samples per second, down to 3.9 samples per second, and user-selectable low-pass filters enable a wide range of cut-off frequencies.

4.7 THREE-AXIS MEMS ACCELEROMETER WITH 16-BIT ADCS AND SIGNAL CONDITIONING

The MPU-6500's 3-Axis accelerometer uses separate proof masses for each axis. Acceleration along a particular axis induces displacement on the corresponding proof mass, and capacitive sensors detect the displacement differentially. The MPU-6500's architecture reduces the accelerometers' susceptibility to fabrication variations as well as to thermal drift. When the device is placed on a flat surface, it will measure $0g$ on the X- and Y-axes and $+1g$ on the Z-axis. The accelerometers' scale factor is calibrated at the factory and is nominally independent of supply voltage. Each sensor has a dedicated sigma-delta ADC for providing digital outputs. The full scale range of the digital output can be adjusted to $\pm 2g$, $\pm 4g$, $\pm 8g$, or $\pm 16g$.

4.8 DIGITAL MOTIONPROCESSOR®

The embedded Digital MotionProcessor® (DMP) within the MPU-6500 offloads computation of motion processing algorithms from the host processor. The DMP acquires data from accelerometers, gyroscopes, and additional 3rd party sensors such as magnetometers, and processes the data. The resulting data can be read from the FIFO. The DMP has access to one of the MPU's external pins, which can be used for generating interrupts.

The purpose of the DMP is to offload both timing requirements and processing power from the host processor. Typically, motion processing algorithms should be run at a high rate, often around 200Hz, in order to provide accurate results with low latency. This is required even if the application updates at a much lower rate; for example, a low power user interface may update as slowly as 5Hz, but the motion processing should still run at 200Hz. The DMP can be used to minimize power, simplify timing, simplify the software architecture, and save valuable MIPS on the host processor for use in applications.

The DMP supports the following functionality:

- Low Power Quaternion (3-Axis Gyroscope)
- Screen Orientation (A low-power implementation of Android's screen rotation algorithm)
- Pedometer (InvenSense implementation)

4.9 PRIMARY I²C AND SPI SERIAL COMMUNICATIONS INTERFACES

The MPU-6500 communicates to a system processor using either a SPI or an I²C serial interface. The MPU-6500 always acts as a slave when communicating to the system processor. The LSB of the of the I²C slave address is set by pin 9 (AD0).

4.9.1 MPU-6500 Solution Using I²C Interface

In the figure below, the system processor is an I²C master to the MPU-6500. In addition, the MPU-6500 is an I²C master to the optional external compass sensor. The MPU-6500 has limited capabilities as an I²C Master, and depends on the system processor to manage the initial configuration of any auxiliary sensors. The MPU-6500 has an interface bypass multiplexer, which connects the system processor I²C bus pins 23 and 24 (SDA and SCL) directly to the auxiliary sensor I²C bus pins 6 and 7 (AUX_DA and AUX_CL).

Once the auxiliary sensors have been configured by the system processor, the interface bypass multiplexer should be disabled so that the MPU-6500 auxiliary I²C master can take control of the sensor I²C bus and gather data from the auxiliary sensors.

For further information regarding I²C master control, please refer to section 6.

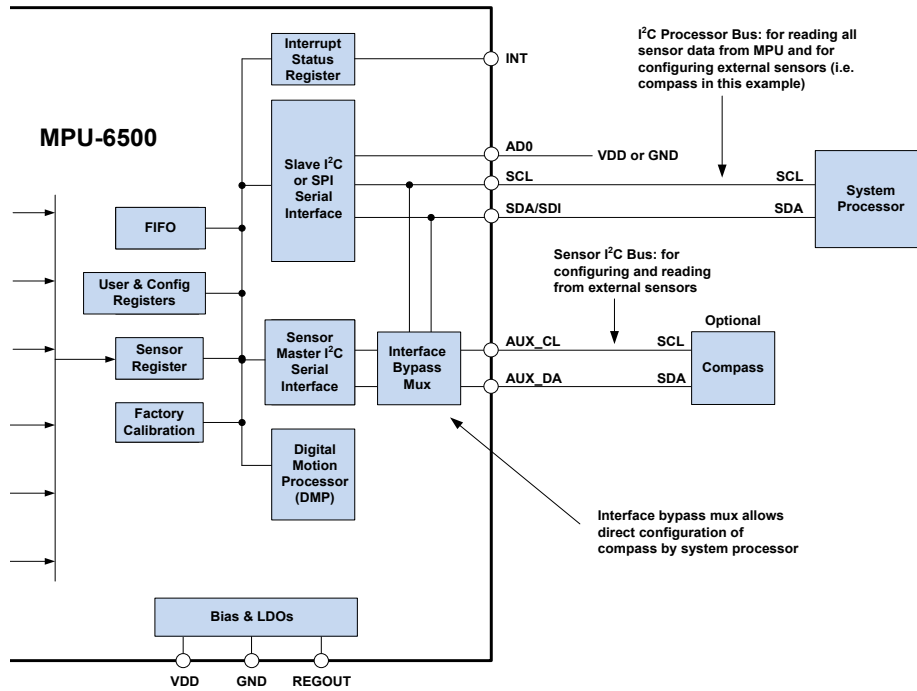

Figure 6. MPU-6500 Solution Using I²C Interface

Note: The Interrupt line should be connected to a pin on the Application Processor (AP) that can bring the AP out of suspend mode.

4.9.2 MPU-6500 Solution Using SPI Interface

In the figure below, the system processor is an SPI master to the MPU-6500. Pins 8, 9, 23, and 24 are used to support the CS, SDO, SCLK, and SDI signals for SPI communications. Because these SPI pins are shared with the I²C slave pins (9, 23 and 24), the system processor cannot access the auxiliary I²C bus through the interface bypass multiplexer, which connects the processor I²C interface pins to the sensor I²C interface pins. Since the MPU-6500 has limited capabilities as an I²C Master, and depends on the system processor to manage the initial configuration of any auxiliary sensors, another method must be used for programming the sensors on the auxiliary sensor I²C bus pins 6 and 7 (AUX_DA and AUX_CL).

When using SPI communications between the MPU-6500 and the system processor, configuration of devices on the auxiliary I²C sensor bus can be achieved by using I²C Slaves 0-4 to perform read and write transactions on any device and register on the auxiliary I²C bus. The I²C Slave 4 interface can be used to perform only single byte read and write transactions. Once the external sensors have been configured, the MPU-6500 can perform single or multi-byte reads using the sensor I²C bus. The read results from the Slave 0-3 controllers can be written to the FIFO buffer as well as to the external sensor registers.

For further information regarding the control of the MPU-6500’s auxiliary I²C interface, please refer to the MPU-6500 Register Map and Register Descriptions document.

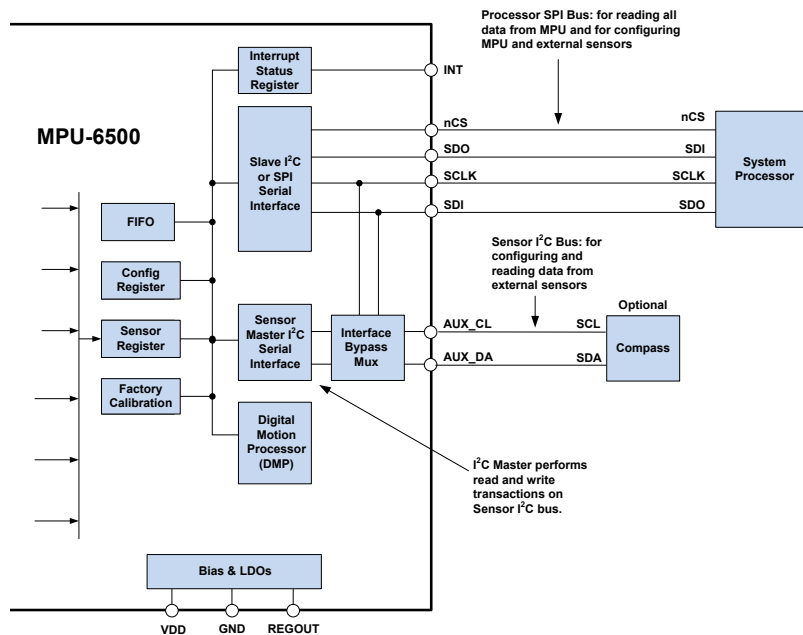

Figure 7. MPU-6500 Solution Using SPI Interface

Note: The Interrupt line should be connected to a pin on the Application Processor (AP) that can bring the AP out of suspend mode.

4.10 AUXILIARY I²C SERIAL INTERFACE

The MPU-6500 has an auxiliary I²C bus for communicating to an off-chip 3-Axis digital output magnetometer or other sensors. This bus has two operating modes:

- **I²C Master Mode:** The MPU-6500 acts as a master to any external sensors connected to the auxiliary I²C bus
- **Pass-Through Mode:** The MPU-6500 directly connects the primary and auxiliary I²C buses together, allowing the system processor to directly communicate with any external sensors.

4.10.1 Auxiliary I²C Bus Modes of Operation:

- **I²C Master Mode:** Allows the MPU-6500 to directly access the data registers of external digital sensors, such as a magnetometer. In this mode, the MPU-6500 directly obtains data from auxiliary sensors without intervention from the system applications processor.

For example, In I²C Master mode, the MPU-6500 can be configured to perform burst reads, returning the following data from a magnetometer:

- X magnetometer data (2 bytes)
- Y magnetometer data (2 bytes)
- Z magnetometer data (2 bytes)

The I²C Master can be configured to read up to 24 bytes from up to 4 auxiliary sensors. A fifth sensor can be configured to work single byte read/write mode.

- **Pass-Through Mode:** Allows an external system processor to act as master and directly communicate to the external sensors connected to the auxiliary I²C bus pins (AUX_DA and AUX_CL). In this mode, the auxiliary I²C bus control logic (3rd party sensor interface block) of the MPU-6500 is disabled, and the auxiliary I²C pins AUX_DA and AUX_CL (Pins 6 and 7) are connected to the main I²C bus (Pins 23 and 24) through analog switches internally. Pass-Through mode is useful for configuring the external sensors, or for keeping the MPU-6500 in a low-power mode when only the external sensors are used. In this mode the system processor can still access MPU-6500 data through the I²C interface.

4.11 SELF-TEST

Please refer to the register map document for more details on self-test.

Self-test allows for the testing of the mechanical and electrical portions of the sensors. The self-test for each measurement axis can be activated by means of the gyroscope and accelerometer self-test registers (registers 13 to 16).

When the self-test is activated, the electronics cause the sensors to be actuated and produce an output signal. The output signal is used to observe the self-test response.

The self-test response is defined as follows:

$$\text{SELF-TEST RESPONSE} = \text{SENSOR OUTPUT WITH SELF-TEST ENABLED} - \text{SENSOR OUTPUT WITHOUT SELF-TEST ENABLED}$$

The self-test response for each gyroscope axis is defined in the gyroscope specification table, while that for each accelerometer axis is defined in the accelerometer specification table.

When the value of the self-test response is within the specified min/max limits of the product specification, the part has passed self-test. When the self-test response exceeds the min/max values, the part is deemed to have failed self-test. It is recommended to use InvenSense MotionApps software for executing self-test.

4.12 CLOCKING

The MPU-6500 has a flexible clocking scheme, allowing a variety of internal clock sources to be used for the internal synchronous circuitry. This synchronous circuitry includes the signal conditioning and ADCs, the DMP, and various control circuits and registers. An on-chip PLL provides flexibility in the allowable inputs for generating this clock.

Allowable internal sources for generating the internal clock are:

- An internal relaxation oscillator
- Any of the X, Y, or Z gyros (MEMS oscillators with a variation of $\pm 1\%$ over temperature)

Selection of the source for generating the internal synchronous clock depends on the requirements for power consumption and clock accuracy. These requirements will most likely vary by mode of operation. For example, in one mode, where the biggest concern is power consumption, the user may wish to operate the Digital MotionProcessor of the MPU-6500 to process accelerometer data, while keeping the gyros off. In this case, the internal relaxation oscillator is a good clock choice. However, in another mode, where the gyros are active, selecting the gyros as the clock source provides for a more accurate clock source.

Clock accuracy is important, since timing errors directly affect the distance and angle calculations performed by the Digital MotionProcessor (and by extension, by any processor).

There are also start-up conditions to consider. When the MPU-6500 first starts up, the device uses its internal clock until programmed to operate from another source. This allows the user, for example, to wait for the MEMS oscillators to stabilize before they are selected as the clock source.

4.13 SENSOR DATA REGISTERS

The sensor data registers contain the latest gyro, accelerometer, auxiliary sensor, and temperature measurement data. They are read-only registers, and are accessed via the serial interface. Data from these registers may be read anytime.

4.14 FIFO

The MPU-6500 contains a 512-byte FIFO register that is accessible via the Serial Interface. The FIFO configuration register determines which data is written into the FIFO. Possible choices include gyro data, accelerometer data, temperature readings, auxiliary sensor readings, and FSYNC input. A FIFO counter keeps track of how many bytes of valid data are contained in the FIFO. The FIFO register supports burst reads. The interrupt function may be used to determine when new data is available.

For further information regarding the FIFO, please refer to the MPU-6500 Register Map and Register Descriptions document.

4.15 INTERRUPTS

Interrupt functionality is configured via the Interrupt Configuration register. Items that are configurable include the INT pin configuration, the interrupt latching and clearing method, and triggers for the interrupt. Items that can trigger an interrupt are (1) Clock generator locked to new reference oscillator (used when switching clock sources); (2) new data is available to be read (from the FIFO and Data registers); (3) accelerometer event interrupts; and (4) the MPU-6500 did not receive an acknowledge from an auxiliary sensor on the secondary I²C bus. The interrupt status can be read from the Interrupt Status register.

For further information regarding interrupts, please refer to the MPU-6500 Register Map and Register Descriptions document.

4.16 DIGITAL-OUTPUT TEMPERATURE SENSOR

An on-chip temperature sensor and ADC are used to measure the MPU-6500 die temperature. The readings from the ADC can be read from the FIFO or the Sensor Data registers.

4.17 BIAS AND LDOS

The bias and LDO section generates the internal supply and the reference voltages and currents required by the MPU-6500. Its two inputs are an unregulated VDD and a VDDIO logic reference supply voltage. The LDO output is bypassed by a capacitor at REGOUT. For further details on the capacitor, please refer to the Bill of Materials for External Components.

4.18 CHARGE PUMP

An on-chip charge pump generates the high voltage required for the MEMS oscillators.

4.19 STANDARD POWER MODES

The following table lists the user-accessible power modes for MPU-6500.

Mode	Name	Gyro	Accel	DMP
1	Sleep Mode	Off	Off	Off
2	Standby Mode	Drive On	Off	Off
3	Low-Power Accelerometer Mode	Off	Duty-Cycled	Off
4	Low-Noise Accelerometer Mode	Off	On	Off
5	Gyroscope Mode	On	Off	On or Off
6	6-Axis Mode	On	On	On or Off

Table 12. Standard Power Modes for MPU-6500

Notes:

1. Power consumption for individual modes can be found in section 3.3.1.

5 PROGRAMMABLE INTERRUPTS

The MPU-6500 has a programmable interrupt system which can generate an interrupt signal on the INT pin. Status flags indicate the source of an interrupt. Interrupt sources may be enabled and disabled individually.

Interrupt Name	Module
Motion Detection	Motion
FIFO Overflow	FIFO
Data Ready	Sensor Registers
I ² C Master errors: Lost Arbitration, NACKs	I ² C Master
I ² C Slave 4	I ² C Master

Table 13. Table of Interrupt Sources

For information regarding the interrupt enable/disable registers and flag registers, please refer to the MPU-6500 Register Map and Register Descriptions document. Some interrupt sources are explained below.

5.1 WAKE-ON-MOTION INTERRUPT

The MPU-6500 provides motion detection capability. A qualifying motion sample is one where the high passed sample from any axis has an absolute value exceeding a user-programmable threshold. The following flowchart explains how to configure the Wake-on-Motion Interrupt. For further details on individual registers, please refer to the MPU-6500 Registers Map and Registers Description document.

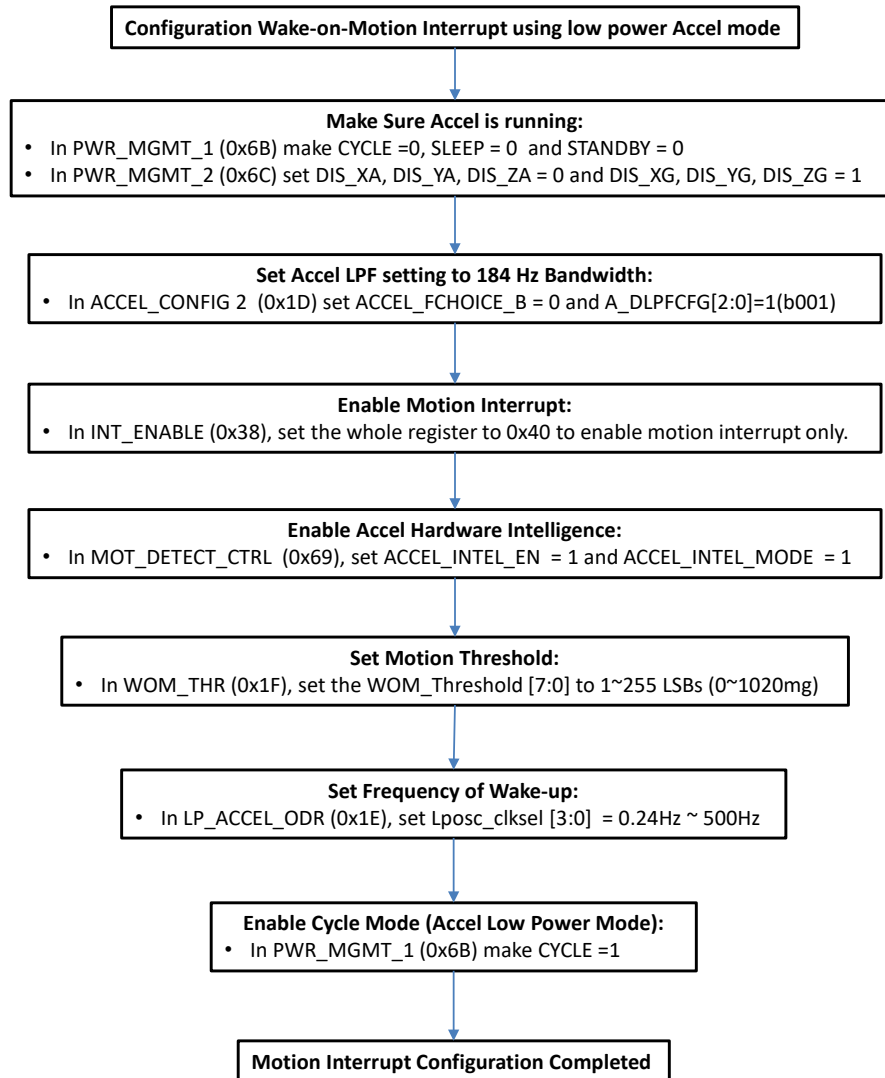

Figure 8. Wake-on-Motion Interrupt Configuration

6 DIGITAL INTERFACE

6.1 I²C AND SPI SERIAL INTERFACES

The internal registers and memory of the MPU-6500 can be accessed using either I²C at 400 kHz or SPI at 1 MHz. SPI operates in four-wire mode.

Pin Number	Pin Name	Pin Description
6	VDDIO	Digital I/O supply voltage.
7	AD0 / SDO	I ² C Slave Address LSB (AD0); SPI serial data output (SDO)
21	SCL / SCLK	I ² C serial clock (SCL); SPI serial clock (SCLK)
22	SDA / SDI	I ² C serial data (SDA); SPI serial data input (SDI)

Table 14. Serial Interface

Note: To prevent switching into I²C mode when using SPI, the I²C interface should be disabled by setting the *I2C_IF_DIS* configuration bit. Setting this bit should be performed immediately after waiting for the time specified by the “Start-Up Time for Register Read/Write” in Section 6.3.

For further information regarding the *I2C_IF_DIS* bit, please refer to the MPU-6500 Register Map and Register Descriptions document.

6.2 I²C INTERFACE

I²C is a two-wire interface comprised of the signals serial data (SDA) and serial clock (SCL). In general, the lines are open-drain and bi-directional. In a generalized I²C interface implementation, attached devices can be a master or a slave. The master device puts the slave address on the bus, and the slave device with the matching address acknowledges the master.

The MPU-6500 always operates as a slave device when communicating to the system processor, which thus acts as the master. SDA and SCL lines typically need pull-up resistors to VDD. The maximum bus speed is 400 kHz.

The slave address of the MPU-6500 is b110100X which is 7 bits long. The LSB bit of the 7 bit address is determined by the logic level on pin AD0. This allows two MPU-6500s to be connected to the same I²C bus. When used in this configuration, the address of the one of the devices should be b1101000 (pin AD0 is logic low) and the address of the other should be b1101001 (pin AD0 is logic high).

6.3 I²C COMMUNICATIONS PROTOCOL

START (S) and STOP (P) Conditions

Communication on the I²C bus starts when the master puts the START condition (S) on the bus, which is defined as a HIGH-to-LOW transition of the SDA line while SCL line is HIGH (see figure below). The bus is considered to be busy until the master puts a STOP condition (P) on the bus, which is defined as a LOW to HIGH transition on the SDA line while SCL is HIGH (see Figure 9).

Additionally, the bus remains busy if a repeated START (Sr) is generated instead of a STOP condition.

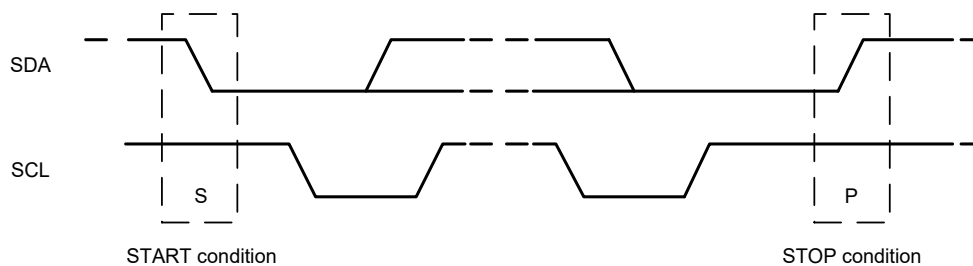

Figure 9. START and STOP Conditions

Data Format / Acknowledge

I²C data bytes are defined to be 8-bits long. There is no restriction to the number of bytes transmitted per data transfer. Each byte transferred must be followed by an acknowledge (ACK) signal. The clock for the acknowledge signal is generated by the master, while the receiver generates the actual acknowledge signal by pulling down SDA and holding it low during the HIGH portion of the acknowledge clock pulse.

If a slave is busy and cannot transmit or receive another byte of data until some other task has been performed, it can hold SCL LOW, thus forcing the master into a wait state. Normal data transfer resumes when the slave is ready and releases the clock line (refer to Figure 10).

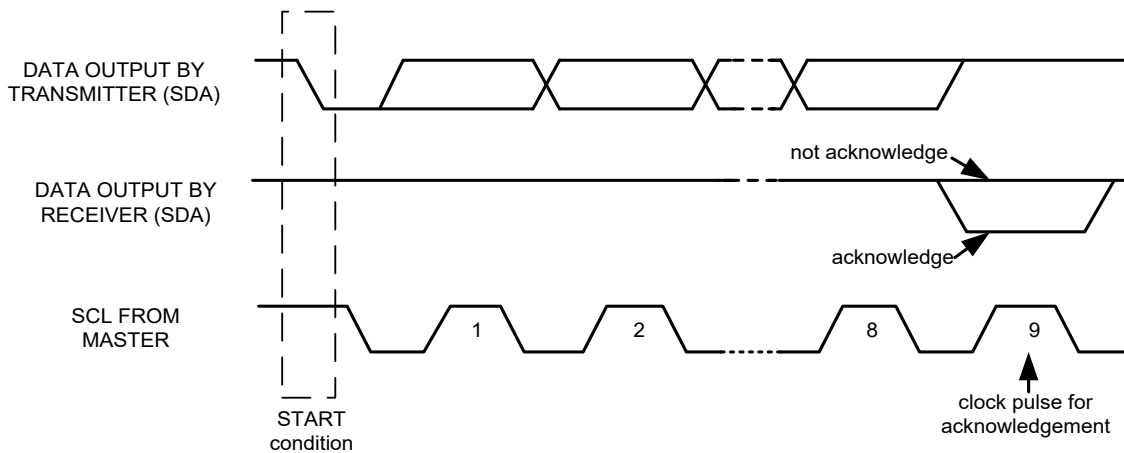

Figure 10. Acknowledge on the I²C Bus

Communications

After beginning communications with the START condition (S), the master sends a 7-bit slave address followed by an 8th bit, the read/write bit. The read/write bit indicates whether the master is receiving data from or is writing to the slave device. Then, the master releases the SDA line and waits for the acknowledge signal (ACK) from the slave device. Each byte transferred must be followed by an acknowledge bit. To acknowledge, the slave device pulls the SDA line LOW and keeps it LOW for the high period of the SCL line. Data transmission is always terminated by the master with a STOP condition (P), thus freeing the communications line. However, the master can generate a repeated START condition (Sr), and address another slave without first generating a STOP condition (P). A LOW to HIGH transition on the SDA line while SCL is HIGH defines the stop condition. All SDA changes should take place when SCL is low, with the exception of start and stop conditions.

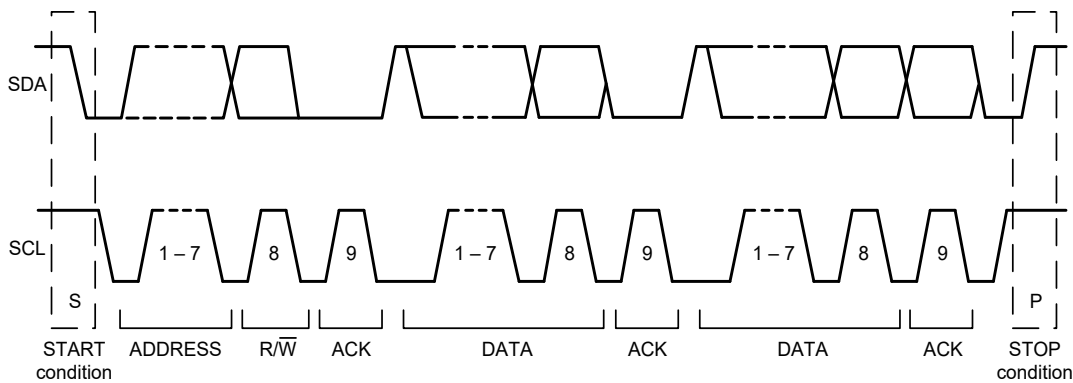

Figure 11. Complete I²C Data Transfer

To write the internal MPU-6500 registers, the master transmits the start condition (S), followed by the I²C address and the write bit (0). At the 9th clock cycle (when the clock is high), the MPU-6500 acknowledges the transfer. Then the master puts the register address (RA) on the bus. After the MPU-6500 acknowledges the reception of the register address, the master puts the register data onto the bus. This is followed by the ACK signal, and data transfer may be concluded by the stop condition (P). To write multiple bytes after the last ACK signal, the master can continue outputting data rather than transmitting a stop signal. In this case, the MPU-6500 automatically increments the register address and loads the data to the appropriate register. The following figures show single and two-byte write sequences.

Single-Byte Write Sequence

Master	S	AD+W		RA		DATA		P
Slave			ACK		ACK		ACK	

Burst Write Sequence

Master	S	AD+W		RA		DATA		DATA		P
Slave			ACK		ACK		ACK		ACK	

To read the internal MPU-6500 registers, the master sends a start condition, followed by the I²C address and a write bit, and then the register address that is going to be read. Upon receiving the ACK signal from the MPU-6500, the master transmits a start signal followed by the slave address and read bit. As a result, the MPU-6500 sends an ACK signal and the data. The communication ends with a not acknowledge (NACK) signal and a stop bit from master. The NACK condition is defined such that the SDA line remains high at the 9th clock cycle. The following figures show single and two-byte read sequences.

Single-Byte Read Sequence

Master	S	AD+W		RA		S	AD+R			NACK	P
Slave			ACK		ACK			ACK	DATA		

Burst Read Sequence

Master	S	AD+W		RA		S	AD+R			ACK		NACK	P
Slave			ACK		ACK			ACK	DATA		DATA		

6.4 I²C TERMS

Signal	Description
S	Start Condition: SDA goes from high to low while SCL is high
AD	Slave I ² C address
W	Write bit (0)
R	Read bit (1)
ACK	Acknowledge: SDA line is low while the SCL line is high at the 9 th clock cycle
NACK	Not-Acknowledge: SDA line stays high at the 9 th clock cycle
RA	MPU-6500 internal register address
DATA	Transmit or received data
P	Stop condition: SDA going from low to high while SCL is high

Table 15. I²C Terms

6.5 SPI INTERFACE

SPI is a 4-wire synchronous serial interface that uses two control lines and two data lines. The MPU-6500 always operates as a Slave device during standard Master-Slave SPI operation.

With respect to the Master, the Serial Clock output (SCLK), the Serial Data Output (SDO) and the Serial Data Input (SDI) are shared among the Slave devices. Each SPI slave device requires its own Chip Select (CS) line from the master.

CS goes low (active) at the start of transmission and goes back high (inactive) at the end. Only one CS line is active at a time, ensuring that only one slave is selected at any given time. The CS lines of the non-selected slave devices are held high, causing their SDO lines to remain in a high-impedance (high-z) state so that they do not interfere with any active devices.

SPI Operational Features

1. Data is delivered MSB first and LSB last
2. Data is latched on the rising edge of SCLK
3. Data should be transitioned on the falling edge of SCLK
4. The maximum frequency of SCLK is 1MHz
5. SPI read and write operations are completed in 16 or more clock cycles (two or more bytes). The first byte contains the SPI Address, and the following byte(s) contain(s) the SPI data. The first bit of the first byte contains the Read/Write bit and indicates the Read (1) or Write (0) operation. The following 7 bits contain the Register Address. In cases of multiple-byte Read/Writes, data is two or more bytes:

SPI Address format

MSB							LSB
R/W	A6	A5	A4	A3	A2	A1	A0

SPI Data format

MSB							LSB
D7	D6	D5	D4	D3	D2	D1	D0

6. Supports Single or Burst Read/Writes.

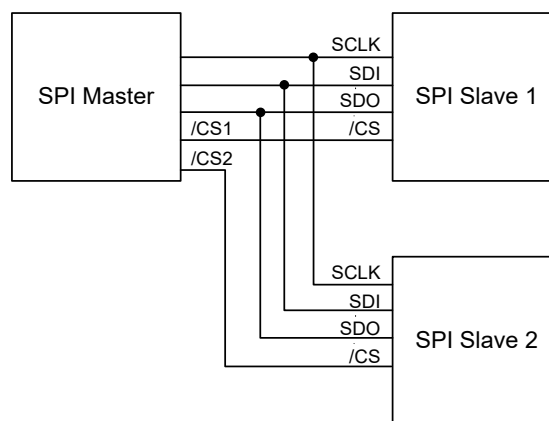

Figure 12. Typical SPI Master / Slave Configuration

7 SERIAL INTERFACE CONSIDERATIONS

7.1 MPU-6500 SUPPORTED INTERFACES

The MPU-6500 supports I²C communications on both its primary (microprocessor) serial interface and its auxiliary interface.

The MPU-6500's I/O logic levels are set to be VDDIO.

The figure below depicts a sample circuit of MPU-6500 with a third-party magnetometer attached to the auxiliary I²C bus. It shows the relevant logic levels and voltage connections.

Note: Actual configuration will depend on the auxiliary sensors used.

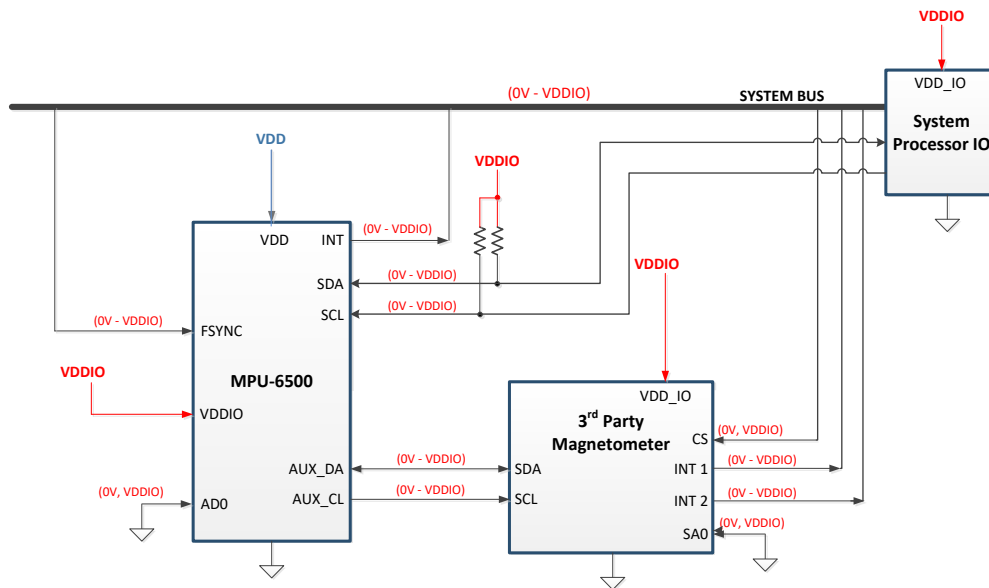

Figure 13. I/O Levels and Connections

Note: The Interrupt line should be connected to a pin on the Application Processor (AP) that can bring the AP out of suspend mode.

8 ASSEMBLY

This section provides general guidelines for assembling InvenSense Micro Electro-Mechanical Systems (MEMS) gyros packaged in Quad Flat No leads package (QFN) surface mount integrated circuits.

8.1 ORIENTATION OF AXES

The diagram below shows the orientation of the axes of sensitivity and the polarity of rotation. Note the pin 1 identifier (•) in the figure.

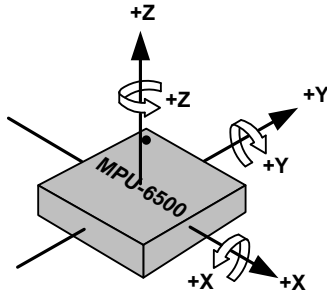
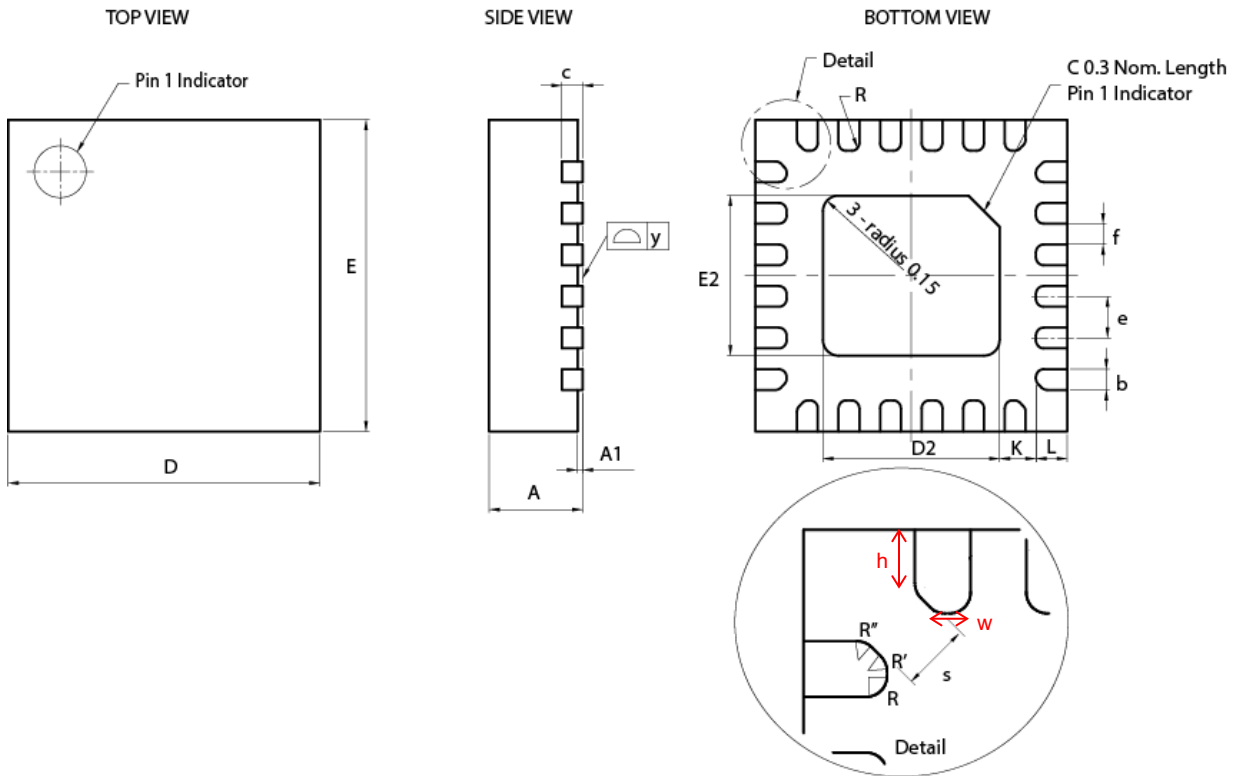

Figure 14. Orientation of Axes of Sensitivity and Polarity of Rotation

8.2 PACKAGE DIMENSIONS

24 Lead QFN (3x3x0.9) mm NiPdAu Lead-frame finish



SYMBOLS	DESCRIPTION	DIMENSIONS IN MILLIMETERS		
		MIN	NOM	MAX
A	Package thickness	0.85	0.90	0.95
A1	Lead finger (pad) seating height	0.00	0.02	0.05
b	Lead finger (pad) width	0.15	0.20	0.25
c	Lead frame (pad) height	---	0.20 REF	---
D	Package width	2.90	3.00	3.10
D2	Exposed pad width	1.65	1.70	1.75
E	Package length	2.90	3.00	3.10
E2	Exposed pad length	1.49	1.54	1.59
e	Lead finger-finger (pad-pad) pitch	---	0.40	---
f (e-b)	Lead-lead (Pad-Pad) space	0.15	0.20	0.25
K	Lead (pad) to Exposed Pad Space	---	0.35 REF	---
L	Lead (pad) length	0.25	0.30	0.35
R	Lead (pad) corner radius	0.075	REF	---
R'	Corner lead (pad) outer radius	0.10	0.11	0.12
R''	Corner lead (pad) inner radius	0.10	0.11	0.12
s	Corner lead-lead (pad-pad) spacing	---	0.25 REF	---
h	Corner lead dimension		0.22	
w	Corner lead dimension		0.12	
y	Lead Conformality	0.00	---	0.075

9 PART NUMBER PACKAGE MARKING

The part number package marking for MPU-6500 devices is summarized below:

Part Number	Part Number Package Marking
MPU-6500	MP65

10 RELIABILITY

10.1 QUALIFICATION TEST POLICY

InvenSense’s products complete a Qualification Test Plan before being released to production. The Qualification Test Plan for the MPU-6500 followed the JESD471 Standards, “Stress-Test-Driven Qualification of Integrated Circuits,” with the individual tests described below.

10.2 QUALIFICATION TEST PLAN

TEST	Method/Condition	Lot Quantity	Sample / Lot	Acc / Reject Criteria
(HTOL/LFR) High Temperature Operating Life	JEDEC JESD22-A108D, Dynamic, 3.63V biased, $T_j > 125^\circ\text{C}$ [read-points 168, 500, 1000 hours]	3	77	(0/1)
(HAST) Highly Accelerated Stress Test ⁽¹⁾	JEDEC JESD22-A118A Condition A, 130°C , 85%RH, 33.3 psia. unbiased, [read-point 96 hours]	3	77	(0/1)
(HTS) High Temperature Storage Life	JEDEC JESD22-A103D, Cond. A, 125°C Non-Bias Bake [read-points 168, 500, 1000 hours]	3	77	(0/1)

Table 16. Accelerated Life Tests

TEST	Method/Condition	Lot Quantity	Sample / Lot	Acc / Reject Criteria
(ESD-HBM) ESD-Human Body Model	ANSI/ESDA/JEDEC JS-001-2012, (2KV)	1	3	(0/1)
(ESD-MM) ESD-Machine Model	JEDEC JESD22-A115C, (250V)	1	3	(0/1)
(LU) Latch Up	JEDEC JESD-78D Class II (2), 125°C ; $\pm 100\text{mA}$	1	6	(0/1)
(MS) Mechanical Shock	JEDEC JESD22-B104C, Mil-Std-883, Method 2002.5, Cond. E, $10,000g's$, 0.2ms, $\pm X, Y, Z$ – 6 directions, 5 times/direction	3	5	(0/1)
(VIB) Vibration	JEDEC JESD22-B103B, Variable Frequency (random), Cond. B, 5-500Hz, X, Y, Z – 4 times/direction	3	5	(0/1)
(TC) Temperature Cycling ⁽¹⁾	JEDEC JESD22-A104D Condition G [-40°C to $+125^\circ\text{C}$], Soak Mode 2 [5'], 1000 cycles	3	77	(0/1)

Table 17. Device Component Level Tests

Note: Tests are preceded by MSL3 Preconditioning in accordance with JEDEC JESD22-A113F

11 REFERENCE

Please refer to “InvenSense MEMS Handling Application Note (AN-IVS-0002A-00)” for the following information:

- Manufacturing Recommendations
 - Assembly Guidelines and Recommendations
 - PCB Design Guidelines and Recommendations
 - MEMS Handling Instructions
 - ESD Considerations
 - Reflow Specification
 - Storage Specifications
 - Package Marking Specification
 - Tape & Reel Specification
 - Reel & Pizza Box Label
 - Packaging
 - Representative Shipping Carton Label
- Compliance
 - Environmental Compliance
 - DRC Compliance
 - Compliance Declaration Disclaimer

12 REVISION HISTORY

Revision Date	Revision	Description
09/18/2013	1.0	Initial Release
03/05/2014	1.1	Updated Sections 1, 2, 4, 9, 11
05/08/2014	1.2	Updated Section 1.2
05/15/2020	1.3	Formatting update

This information furnished by InvenSense, Inc. (“InvenSense”) is believed to be accurate and reliable. However, no responsibility is assumed by InvenSense for its use, or for any infringements of patents or other rights of third parties that may result from its use. Specifications are subject to change without notice. InvenSense reserves the right to make changes to this product, including its circuits and software, in order to improve its design and/or performance, without prior notice. InvenSense makes no warranties, neither expressed nor implied, regarding the information and specifications contained in this document. InvenSense assumes no responsibility for any claims or damages arising from information contained in this document, or from the use of products and services detailed therein. This includes, but is not limited to, claims or damages based on the infringement of patents, copyrights, mask work and/or other intellectual property rights.

Certain intellectual property owned by InvenSense and described in this document is patent protected. No license is granted by implication or otherwise under any patent or patent rights of InvenSense. This publication supersedes and replaces all information previously supplied. Trademarks that are registered trademarks are the property of their respective companies. InvenSense sensors should not be used or sold in the development, storage, production or utilization of any conventional or mass-destructive weapons or for any other weapons or life threatening applications, as well as in any other life critical applications such as medical equipment, transportation, aerospace and nuclear instruments, undersea equipment, power plant equipment, disaster prevention and crime prevention equipment.

©2013—2020 InvenSense. All rights reserved. InvenSense, MotionTracking®, MotionProcessing®, MotionProcessor®, MotionFusion®, MotionApps®, DMP, AAR®, and the InvenSense® logo are trademarks of InvenSense, Inc. The TDK logo is a trademark of TDK Corporation. Other company and product names may be trademarks of the respective companies with which they are associated.



©2013—2020 InvenSense. All rights reserved.