

MATERIAL NO. LOOSE PIECE	ENG. NO.	MATERIAL NO. TAPE MOUNTED	ENG. NO.	STUD SIZE	±.003 "S"	STOCK THICKNESS
191930132	C-340-10	191930133	C-340-10T	10	.198	.040 (1.02)
191930134	C-340-14	191930135	C-340-14T	1/4	.265	
191930141	C-340-56	191930142	C-340-56T	5/16	.328	
191930137	C-340-38	191930139	C-340-38T	3/8	.390	

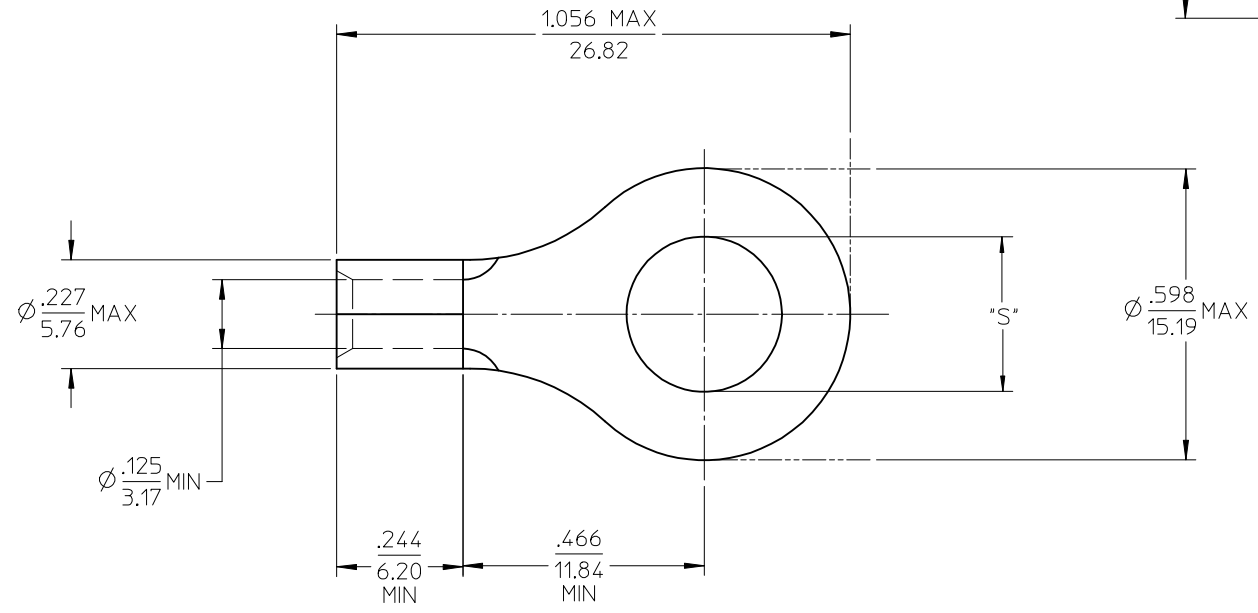
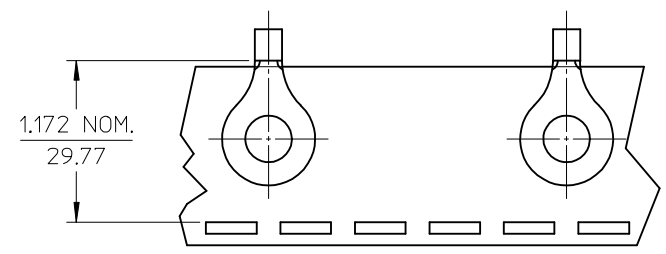

# SALES DRAWING

- NOTE(S):
1. MATERIAL: COPPER
  2. PLATING: ELECTROPLATE TIN
  3. ALL DIMENSIONS IN INCHES/(MM).
  4. WIRE SIZE: 12-10 AWG  
4.0-6.0 MM<sup>2</sup>

REVISED/UPDATE TO MX STDS EC NO: ETC2003-0315 DRWN: DMYRICK 2003/08/20 CHKD: HEB 2003/08/21 APPR: RDEROSS 2003/08/21	DESCRIPTION A	QUALITY SYMBOLS	GENERAL TOLERANCES (UNLESS SPECIFIED)	SCALE 4:1	DESIGN UNITS INCH	THIRD ANGLE PROJECTION	REVISE ON CAD ONLY																
		▽ - 0 ∇ - 0	<table border="1"> <thead> <tr> <th></th> <th>mm</th> <th>INCH</th> </tr> </thead> <tbody> <tr> <td>4 PLACES</td> <td>± ---</td> <td>± ---</td> </tr> <tr> <td>3 PLACES</td> <td>± ---</td> <td>± .005</td> </tr> <tr> <td>2 PLACES</td> <td>± 0.13</td> <td>± .01</td> </tr> <tr> <td>1 PLACE</td> <td>± 0.25</td> <td>± ---</td> </tr> </tbody> </table>		mm	INCH	4 PLACES	± ---	± ---	3 PLACES	± ---	± .005	2 PLACES	± 0.13	± .01	1 PLACE	± 0.25	± ---	DIMENSION STYLE IN/MM	DRAWN BY DLM	DATE 03/06/13	RING TONGUE TERMINAL VERSAKRIMP 12-10 AWG	
			mm	INCH																			
		4 PLACES	± ---	± ---																			
3 PLACES	± ---	± .005																					
2 PLACES	± 0.13	± .01																					
1 PLACE	± 0.25	± ---																					
ANGULAR ±1/2°		CHECKED BY HEB	DATE 03/06/13	MOLEX INCORPORATED																			
DRAFT WHERE APPLICABLE MUST REMAIN WITHIN DIMENSIONS		APPROVED BY RWD	DATE 03/06/13			MATERIAL NO. (SEE CHART)	DOCUMENT NO. SD-19193-026	SHEET NO. 1 OF 1															
THIS DRAWING CONTAINS INFORMATION THAT IS PROPRIETARY TO MOLEX INCORPORATED AND SHOULD NOT BE USED WITHOUT WRITTEN PERMISSION																							