



SPECIFICATION FOR DYNAMIC SPEAKER

TOTAL PAGE 09 www.bestargroups.com RoHS

Preliminary Specification For The Acoustic Characteristics of dynamic Speaker

Customer		Model Name	BMS28-12B-08H05CW150M LF
Customer P/N		Product No.	131452
Date	3 Jan. 19	Issue No.	BS/TES01.1743A
Page	01 of 09	Issue Date	2019/01/04

Approval:

- 1.Characteristics
- 2.Drawing
- 3.Reliability Test
- 4.Packing
- 5.History Change Record

Drawn by	Checked by	Approved by	Customer approved
周嘉明	王 平	赵 峥	

BESTAR HOLDING CO.,LTD

No.199 HuangHe West Road,New district,ChangZhou,JiangSu Province,P.R.China

Tel: +86 519 88222567

Fax: +86 519 88222551

E-mail: wu@be-star.com

<http://www.bestargroups.com>

BMS28-12B-08H05CW150M LF

1. Characteristic

1.1 Electrical and Mechanical Characteristics

No.	Item	Specification
1.	Impedance(at 1kHz)	$8 \pm 15\% \Omega$
2.	Rated Input Power	0.8W
3.	Maximum Input Power	1.2W
4.	Resonance Frequency	$650 \pm 20\% \text{Hz}$
5.	Frequency Response	$F_0 \sim 20\text{kHz}$
6.	Output SPL (at 0.1W/0.1m)	$90 \pm 3\text{dB}$ at 600 Hz
7.	Distortion (at 1kHz,0.5W)	$\leq 5\%$
8.	Buzzes & Rattles	Must be normal at sine wave 2.53V
9.	Magnet	NdFeB
10.	Operating Temperature	$-20 \dots +70 \text{ }^\circ\text{C}$
11.	Storage Temperature	$-40 \dots +85 \text{ }^\circ\text{C}$

1.2 Test Method

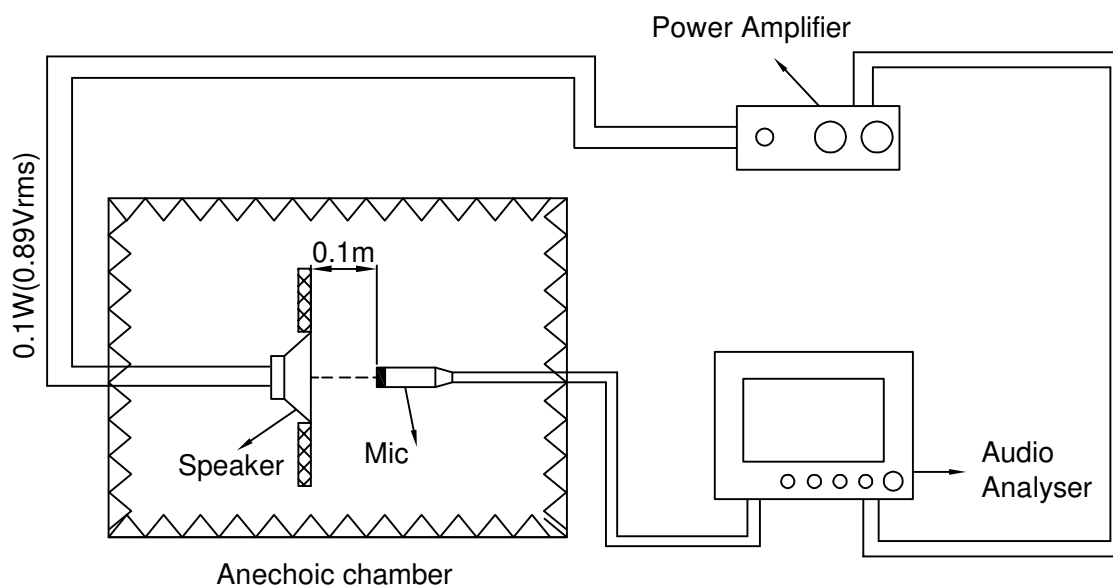

This print and information there in are proprietary to Bestar Holding Co., Ltd. and shall not be used in whole or in part without its written content

				Date:	2019/01/03	BMS28-12B-08H05CW150M LF
				Drawn by:	周嘉明	
A	2019/01/03	周嘉明		Checked by:	王平	Speaker
Rev.	Date	Drawn	Note	Approved by:	赵峥	
BESTAR HOLDING CO.,LTD						
www.bestargroups.com wu@be-star.com						DRG NO: BS/TES01.1743A
						Page:2 of 9

BMS28-12B-08H05CW150M LF

1.3 Fundamental (0.1W/0.1m SOUNDCHECK testing)

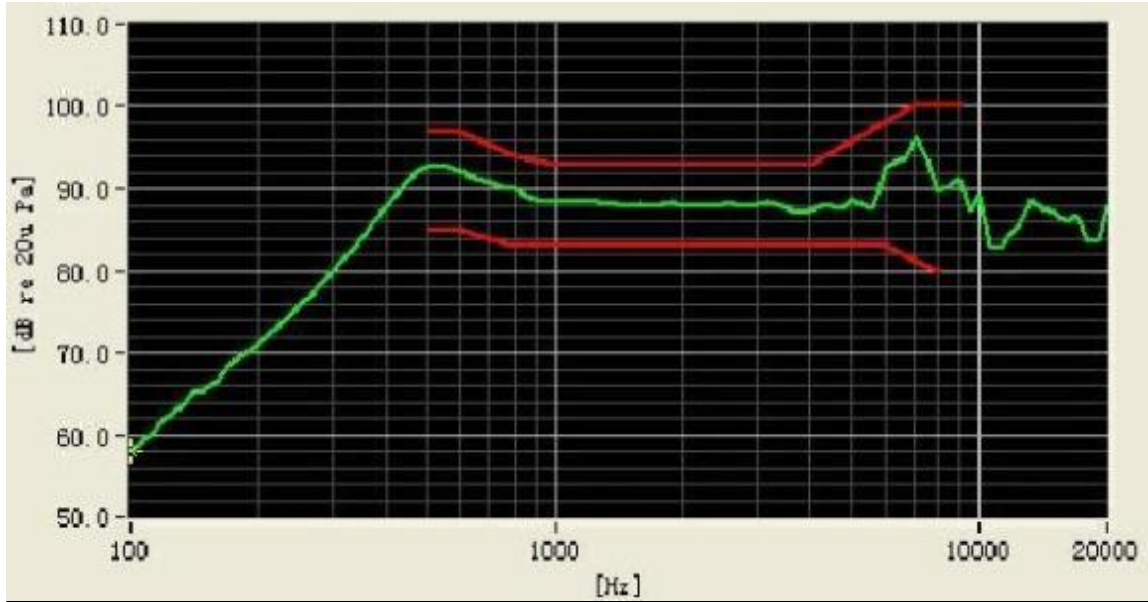

1.4 THD (0.1W/0.1m SOUNDCHECK testing)

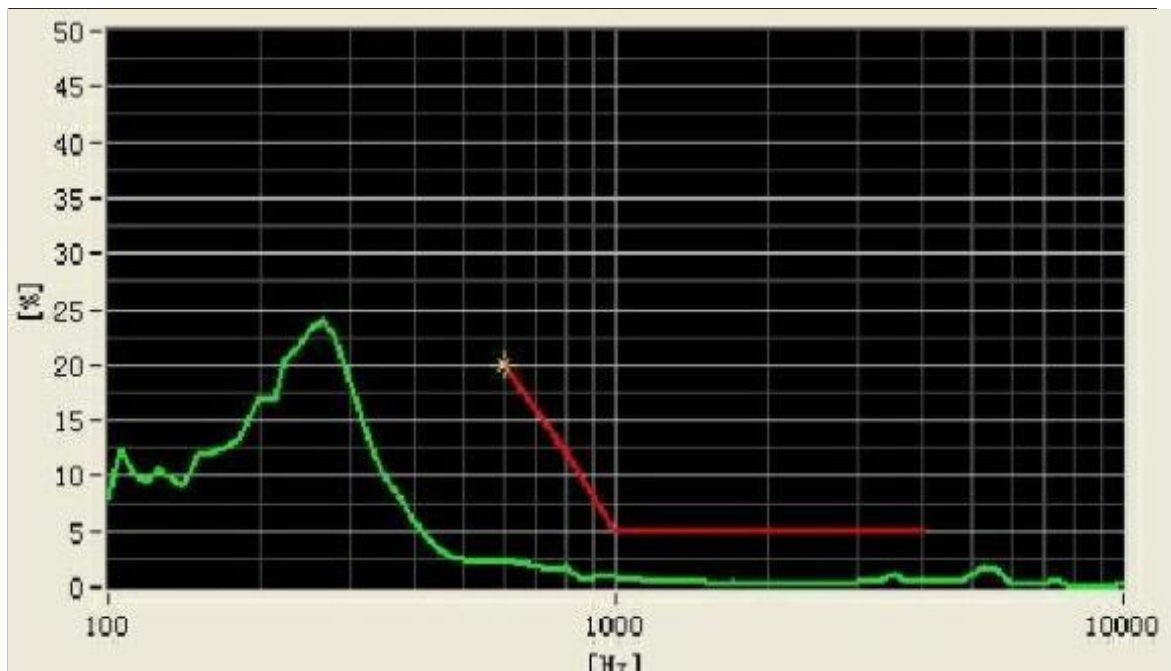

This print and information there in are proprietary to Bestar Holding Co., Ltd. and shall not be used in whole or in part without its written content

				Date:	2019/01/03	BMS28-12B-08H05CW150M LF	
				Drawn by:	周嘉明		
A	2019/01/03	周嘉明		Checked by:	王平	Speaker	
Rev.	Date	Drawn	Note	Approved by:	赵峥		
BESTAR HOLDING CO.,LTD						DRG NO: BS/TES01.1743A	Page:3 of 9
www.bestargroups.com wu@be-star.com							

BMS28-12B-08H05CW150M LF

1.5 Impedance (0.1W/0.1m SOUNDCHECK testing)

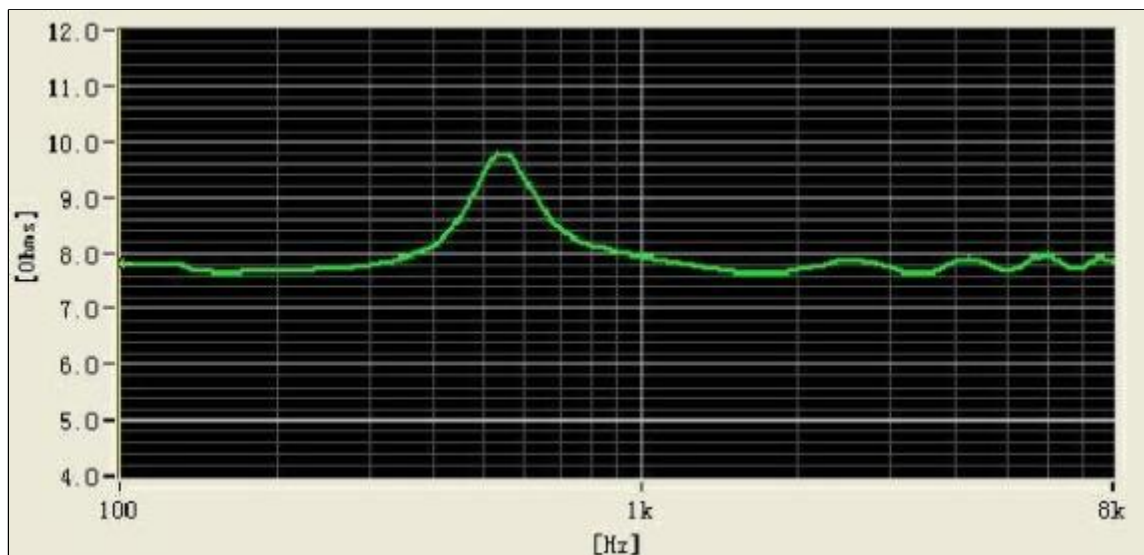

1.6 Rub&buzz (0.1W/0.1m SOUNDCHECK testing)

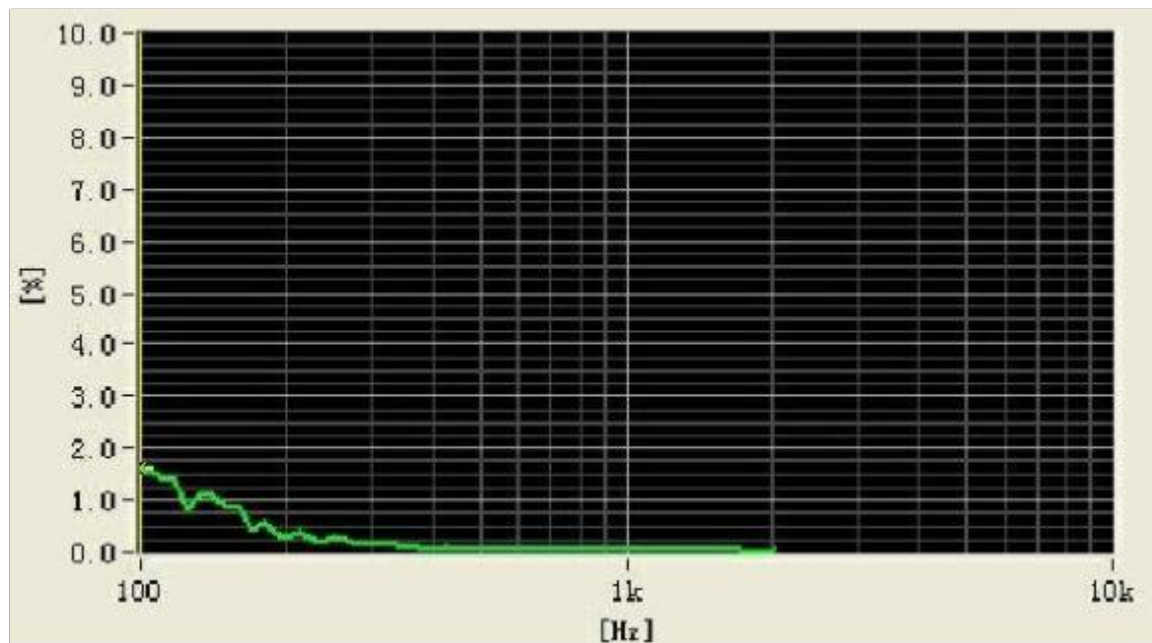

This print and information there in are proprietary to Bestar Holding Co., Ltd. and shall not be used in whole or in part without its written content

				Date:	2019/01/03	BMS28-12B-08H05CW150M LF	
				Drawn by:	周嘉明		
A	2019/01/03	周嘉明		Checked by:	王平	Speaker	
Rev.	Date	Drawn	Note	Approved by:	赵峥		
BESTAR HOLDING CO.,LTD						DRG NO: BS/TES01.1743A	Page:4 of 9
www.bestargroups.com wu@be-star.com							

BMS28-12B-08H05CW150M LF

2. Drawing

2.1 Dimensions

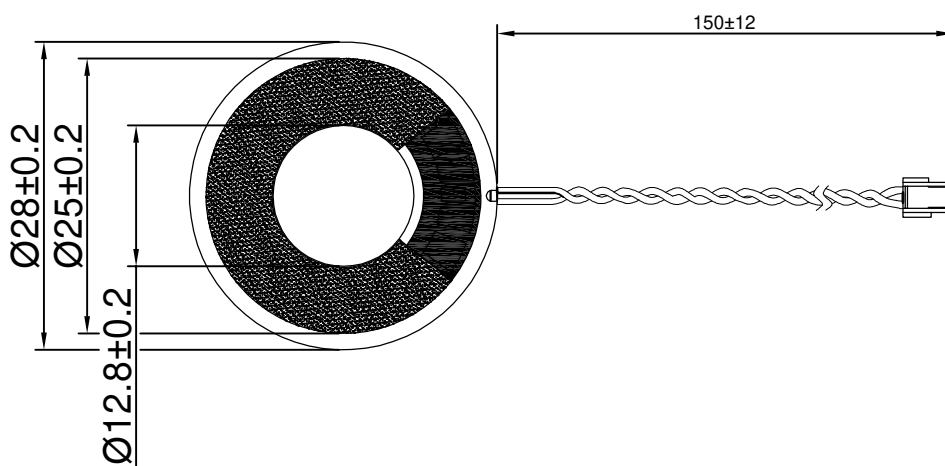
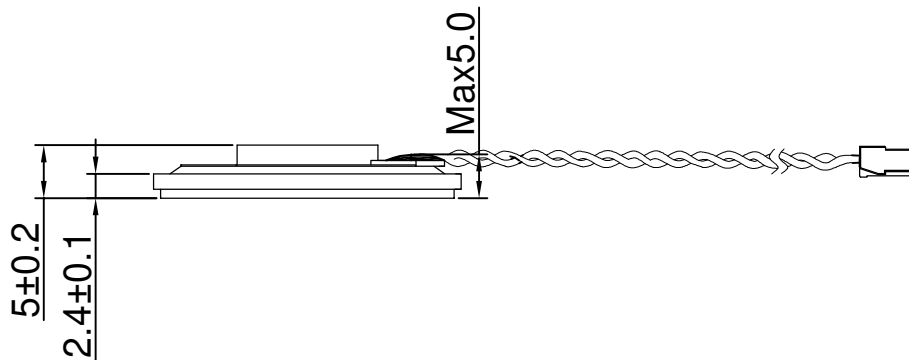
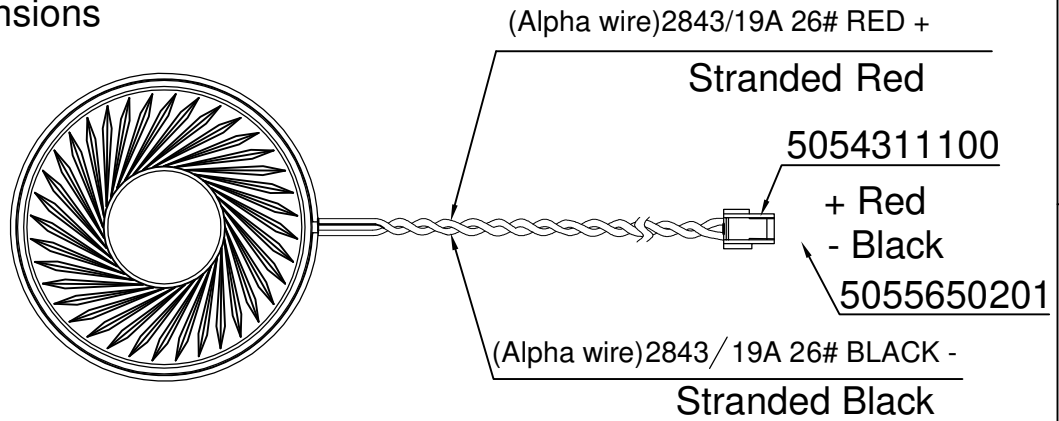

Unit:mm

This print and information there in are proprietary to Bestar Holding Co., Ltd. and shall not be used in whole or in part without its written content

				Date:	2019/01/03	BMS28-12B-08H05CW150M LF	
				Drawn by:	周嘉明		
A	2019/01/03	周嘉明		Checked by:	王平	Speaker	
Rev.	Date	Drawn	Note	Approved by:	赵峥		
BESTAR HOLDING CO.,LTD						DRG NO: BS/TES01.1743A	Page:5 of 9
www.bestargroups.com wu@be-star.com							

BMS28-12B-08H05CW150M LF

2.2 Bill of Material

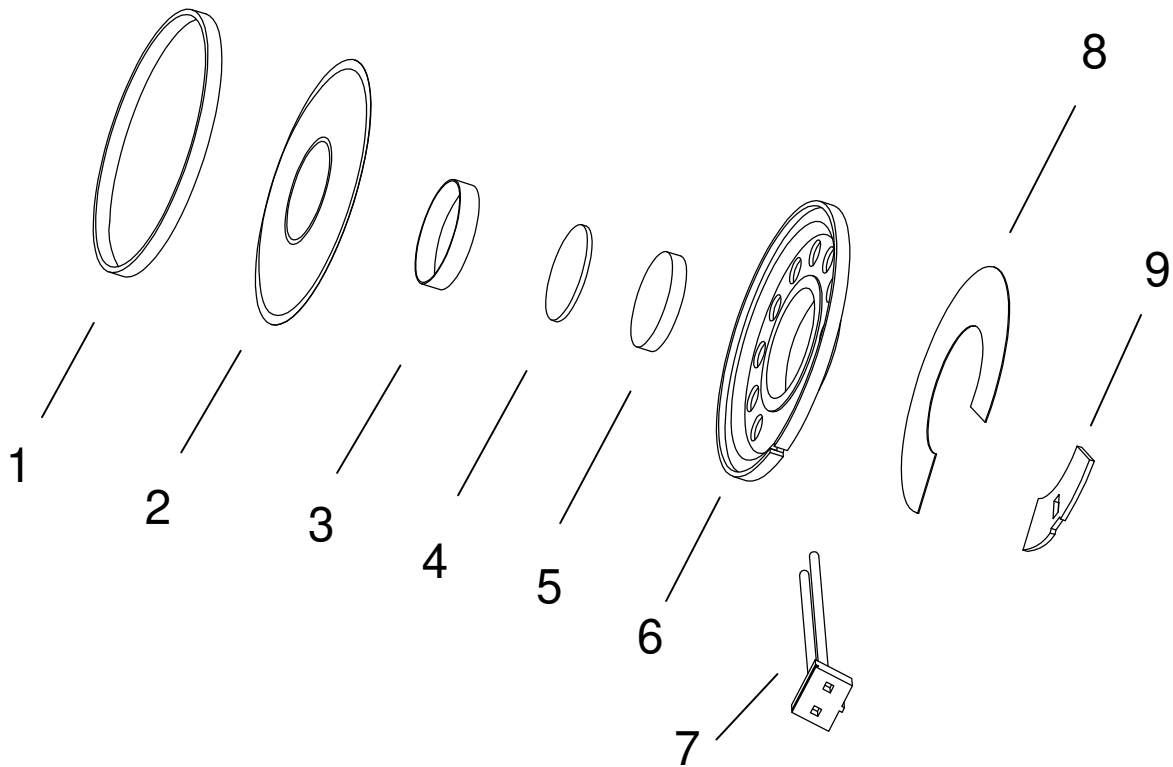

9	PCB	Epoxy and Cu(plating Sn)
8	Mesh	Cloth
7	Plug wire	Cu and PVC
6	Frame	SPCC
5	Magnet	NdFeB
4	Plate	SPCC
3	Voice coil	Cu
2	Diaphragm	PEN
1	Gasket	ABS
No	Parts Name	Material

				Date:	2019/01/03	BMS28-12B-08H05CW150M LF	
				Drawn by:	周嘉明		
A	2019/01/03	周嘉明		Checked by:	王平	Speaker	
Rev.	Date	Drawn	Note	Approved by:	赵峰		
BESTAR HOLDING CO.,LTD						DRG NO: BS/TES01.1743A	Page:6 of 9
www.bestargroups.com wu@be-star.com							

This print and information there in are proprietary to Bestar Holding Co., Ltd. and shall not be used in whole or in part without its written content.

BMS28-12B-08H05CW150M LF

3. Reliability Test

- 3.1 Load Test
 - Power 0.8W White noise
 - Duration 96hrs
- 3.2 High Temperature Test
 - Temperature $+85\pm 3^{\circ}\text{C}$
 - Duration 96hrs
- 3.3 Low Temperature Test
 - Temperature $-40\pm 3^{\circ}\text{C}$
 - Duration 96hrs
- 3.4 Damp Heat
 - Temperature $40\pm 3^{\circ}\text{C}$
 - Relative Humidity 90%-95%RH
 - Duration 96hrs
- 3.5 Temperature Cycle Test
 - Cycle 5
 - 0.8W, F0~3500Hz, White noise

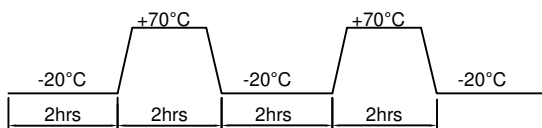

- 3.6 Drop Test
 - Height 75cm (in state of packing)
 - Times 10 (Drop onto hardwood board)
- 3.7 Vibration Test
 - 10 ~ 55 ~ 10Hz sin-wave sweep 15min. 5G (constant) X,Y,Z 3 directions 32 hours each, total 96 hours, 0.8W, F0~3500Hz, White noise
- 3.8 Lead wire pull strength
 - 3.0N for 30 sec. Horizontal, 2.0N 30 sec. vertical

Notice

1. Immediately after reliability test, the samples shall be stored under typical ambient laboratory climate conditions unless otherwise noted for 4 hours prior to performing verification testing.
2. After reliability test, all samples must meet all specified requirements
3. Sensitivity differences at F0 ~ 5.0Khz must be within +/-3 of initial values.

				Date:	2019/01/03	BMS28-12B-08H05CW150M LF	
				Drawn by:	周嘉明		
A	2019/01/03	周嘉明		Checked by:	王平	Speaker	
Rev.	Date	Drawn	Note	Approved by:	赵峰		
BESTAR HOLDING CO.,LTD						DRG NO: BS/TES01.1743A	Page:7 of 9
www.bestargroups.com wu@be-star.com							

This print and information there in are proprietary to Bestar Holding Co., Ltd. and shall not be used in whole or in part without its written content

BMS28-12B-08H05CW150M LF

4. Packing

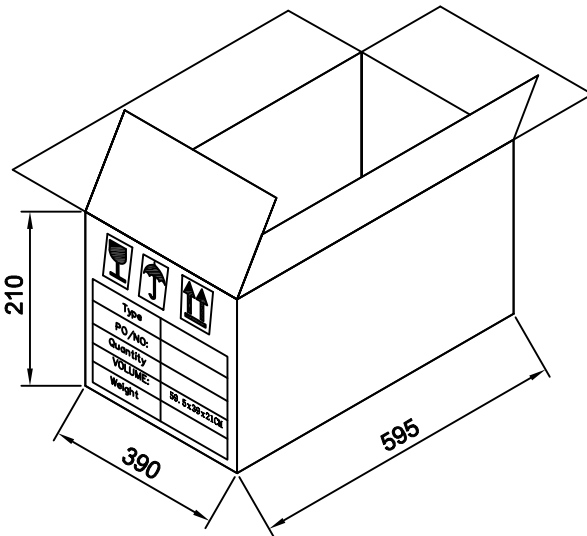
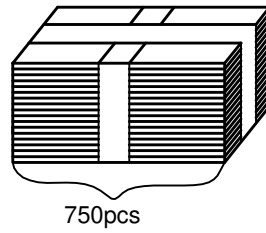
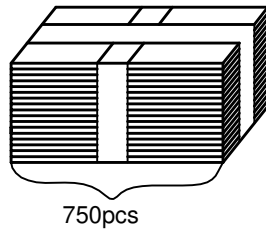
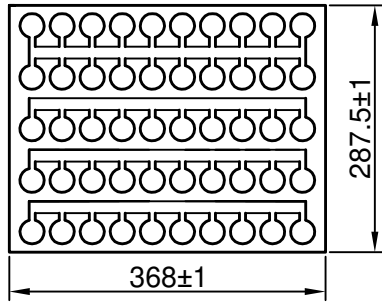

This print and information there in are proprietary to Bestar Holding Co., Ltd. and shall not be used in whole or in part without its written content.

				Date:	2019/01/03	BMS28-12B-08H05CW150M LF	
				Drawn by:	周嘉明		
A	2019/01/03	周嘉明		Checked by:	王平	Speaker	
Rev.	Date	Drawn	Note	Approved by:	赵峥		
BESTAR HOLDING CO.,LTD						DRG NO: BS/TES01.1743A	Page:8 of 9
www.bestargroups.com wu@be-star.com							

BMS28-12B-08H05CW150M LF

5. History change record

version No.	Change Items		Date	Drawn	Approved
	Before	After			
D	Change the wire		19/01/03	周嘉明	赵 崢

This print and information there in are proprietary to Bestar Holding Co., Ltd. and shall not be used in whole or in part without its written content

Date:		2019/01/03		BMS28-12B-08H05CW150M LF	
Drawn by:		周嘉明			
A	2019/01/03	周嘉明	Checked by:	王 平	Speaker
Rev.	Date	Drawn	Approved by:	赵 崢	
BESTAR HOLDING CO.,LTD				www.bestargroups.com wu@be-star.com	
				DRG NO: BS/TES01.1743A	Page:9 of 9