

STRAIGHT JACK SOLDER TYPE

R125.225.000

CABLE .141

Series : SMA

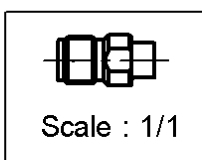
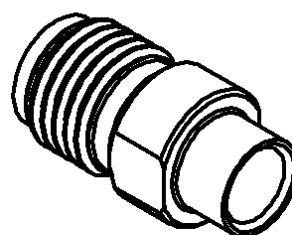
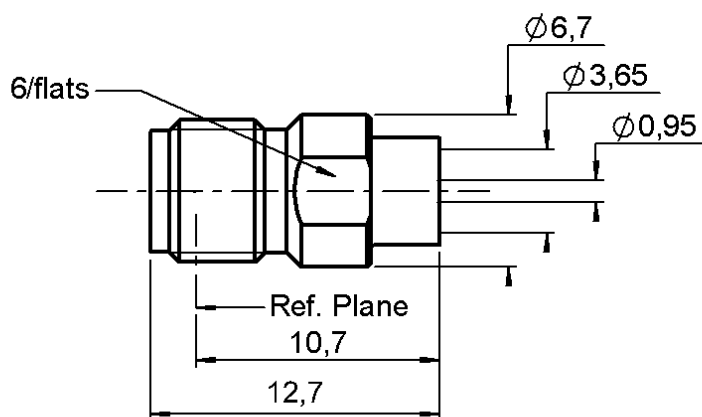

CECC 22111-804-01

All dimensions are in mm.



COMPONENTS	MATERIALS	PLATINGS (µm)
BODY	STAINLESS STEEL	GOLD 0.5 OVER NICKEL 2
CENTER CONTACT	BERYLLIUM COPPER	GOLD 1.3 OVER NICKEL 2
OUTER CONTACT	-	-
INSULATOR	PTFE	-
GASKET	-	-
OTHERS PARTS	-	-
-	-	-
-	-	-

Issue : 0122 L

In the effort to improve our products, we reserve the right to make changes judged to be necessary.



STRAIGHT JACK SOLDER TYPE

R125.225.000

CABLE .141

Series : SMA

PACKAGING

Standard	Unit	Other
100	'W' option	Contact us

SPECIFICATION

4051 571 - -

ELECTRICAL CHARACTERISTICS

Impedance		50	Ω
Frequency		0-18	GHz
VSWR	1.05 +	0.008	x F(GHz) Maxi
Insertion loss		0.03	\sqrt{F} (GHz) dB Maxi
RF leakage	- (90	- F(GHz)) dB Maxi
Voltage rating		500	Veff Maxi
Dielectric withstanding voltage		1000	Veff mini
Insulation resistance		5000	M Ω mini

CABLE ASSEMBLY

Stripping	a	b	c	d	e	f
mm	3.17	0.00	0.00	0.00	0.00	0.00

Assembly instruction : **Solder 01**

Recommended cable(s)
KS 2
RG 402

Cable retention
- pull off **270** N mini
- torque **NA** N.cm

MECHANICAL CHARACTERISTICS

Center contact retention		
Axial force – Mating end	NA	N mini
Axial force – Opposite end	NA	N mini
Torque	NA	N.cm mini

Recommended torque		
Mating	NA	N.cm
Panel nut	NA	N.cm
Clamp nut	NA	N.cm
A/F clamp nut	6.000	mm

Mating life	500	Cycles mini
Weight	1.600	g

TOOLING

Part Number	Description	Hexagon
R282.120.010	SMA TOOLBOX	
R282.053.000	STRIPPING TOOL	
R282.067.000	POINTER GAUGE	
R282.730.043	INSULATOR MOUNTING TOOL	
R282.740.000	SOLDERING MOUNTING	
R282.744.011	SOLDERING POSITIONER (BODY)	
R282.744.220	SOLDERING POSITIONER (CENTER CONTACT)	
R282.862.060	CONTROL GAUGE	
R282.914.010	DIELETRIC RECESS GAUGE	
R282.915.010	DIELECTRIC RECESS TOOL	

ENVIRONMENTAL

Operating temperature	-65/+105	$^{\circ}$ C
Hermetic seal	NA	Atm.cm3/s
Panel leakage	NA	

OTHERS CHARACTERISTICS

nach E 2330-023

Issue : 0122 L

In the effort to improve our products, we reserve the right to make changes judged to be necessary.

