

FEATURES

CMOS 8-Bit 32 MSPS Sampling A/D Converter
Pin-Compatible with AD876-8
Power Dissipation: 95 mW (3 V Supply)
Operation Between +2.7 V and +5.5 V Supply
Differential Nonlinearity: 0.2 LSB
Power-Down (Sleep) Mode
Three-State Outputs
Out-of-Range Indicator
Built-In Clamp Function (DC Restore)
Adjustable On-Chip Voltage Reference
IF Undersampling to 135 MHz

PRODUCT DESCRIPTION

The AD9280 is a monolithic, single supply, 8-bit, 32 MSPS analog-to-digital converter with an on-chip sample-and-hold amplifier and voltage reference. The AD9280 uses a multistage differential pipeline architecture at 32 MSPS data rates and guarantees no missing codes over the full operating temperature range.

The input of the AD9280 has been designed to ease the development of both imaging and communications systems. The user can select a variety of input ranges and offsets and can drive the input either single-ended or differentially.

The sample-and-hold amplifier (SHA) is equally suited for both multiplexed systems that switch full-scale voltage levels in successive channels and sampling single-channel inputs at frequencies up to and beyond the Nyquist rate. AC-coupled input signals can be shifted to a predetermined level, with an onboard clamp circuit. The dynamic performance is excellent.

The AD9280 has an onboard programmable reference. An external reference can also be chosen to suit the dc accuracy and temperature drift requirements of the application.

A single clock input is used to control all internal conversion cycles. The digital output data is presented in straight binary output format. An out-of-range signal (OTR) indicates an overflow condition which can be used with the most significant bit to determine low or high overflow.

The AD9280 can operate with a supply range from +2.7 V to +5.5 V, ideally suiting it for low power operation in high speed applications.

The AD9280 is specified over the industrial (-40°C to $+85^{\circ}\text{C}$) temperature range.

PRODUCT HIGHLIGHTS

Low Power

The AD9280 consumes 95 mW on a 3 V supply (excluding the reference power). In sleep mode, power is reduced to below 5 mW.

Very Small Package

The AD9280 is available in a 28-lead SSOP package.

Pin Compatible with AD876-8

The AD9280 is pin compatible with the AD876-8, allowing older designs to migrate to lower supply voltages.

300 MHz Onboard Sample-and-Hold

The versatile SHA input can be configured for either single-ended or differential inputs.

Out-of-Range Indicator

The OTR output bit indicates when the input signal is beyond the AD9280's input range.

Built-In Clamp Function

Allows dc restoration of video signals.

FUNCTIONAL BLOCK DIAGRAM

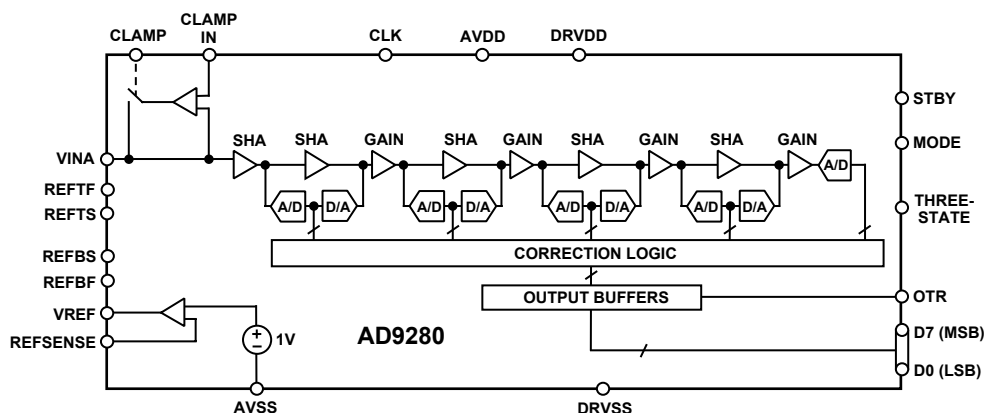

REV. E

Information furnished by Analog Devices is believed to be accurate and reliable. However, no responsibility is assumed by Analog Devices for its use, nor for any infringements of patents or other rights of third parties which may result from its use. No license is granted by implication or otherwise under any patent or patent rights of Analog Devices.

AD9280—SPECIFICATIONS (AVDD = +3 V, DRVDD = +3 V, F_S = 32 MHz (50% Duty Cycle), MODE = AVDD, 2 V Input Span from 0.5 V to 2.5 V, External Reference, T_{MIN} to T_{MAX} unless otherwise noted)

Parameter	Symbol	Min	Typ	Max	Units	Condition
RESOLUTION			8		Bits	
CONVERSION RATE	F _S			32	MHz	
DC ACCURACY						
Differential Nonlinearity	DNL		±0.2	±1.0	LSB	REFTS = 2.5 V, REFBS = 0.5 V
Integral Nonlinearity	INL		±0.3	±1.5	LSB	
Offset Error	E _{ZS}		±0.2	±1.8	% FSR	
Gain Error	E _{FS}		±1.2	±3.9	% FSR	
REFERENCE VOLTAGES						
Top Reference Voltage	REFTS	1		AVDD	V	
Bottom Reference Voltage	REFBS	GND		AVDD - 1	V	
Differential Reference Voltage			2		V p-p	
Reference Input Resistance ¹			10		kΩ	REFTS, REFBS: MODE = AVDD
			4.2		kΩ	Between REFTF & REFBF: MODE = AVSS
ANALOG INPUT						
Input Voltage Range	A _{IN}	REFBS		REFTS	V	REFBS Min = GND; REFTS Max = AVDD
Input Capacitance	C _{IN}		1		pF	Switched
Aperture Delay	t _{AP}		4		ns	
Aperture Uncertainty (Jitter)	t _{AJ}		2		ps	
Input Bandwidth (-3 dB)	BW					
Full Power (0 dB)			300		MHz	
DC Leakage Current			43		μA	Input = ±FS
INTERNAL REFERENCE						
Output Voltage (1 V Mode)	VREF		1		V	REFSENSE = VREF
Output Voltage Tolerance (1 V Mode)			±10	±25	mV	
Output Voltage (2 V Mode)	VREF		2		V	REFSENSE = GND
Load Regulation (1 V Mode)			0.5	2	mV	1 mA Load Current
POWER SUPPLY						
Operating Voltage	AVDD	2.7	3	5.5	V	
	DRVDD	2.7	3	5.5	V	
Supply Current	I _{AVDD}		31.7	36.7	mA	AVDD = 3 V, MODE = AVSS
Power Consumption	P _D		95	110	mW	AVDD = DRVDD = 3 V, MODE = AVSS
Power-Down			4		mW	STBY = AVDD, MODE and CLOCK = AVSS
Gain Error Power Supply Rejection	PSRR		1		% FS	
DYNAMIC PERFORMANCE (A _{IN} = 0.5 dBFS)						
Signal-to-Noise and Distortion	SINAD					
f = 3.58 MHz		46.4	49		dB	
f = 16 MHz			48		dB	
Effective Bits						
f = 3.58 MHz			7.8		Bits	
f = 16 MHz			7.7		Bits	
Signal-to-Noise	SNR					
f = 3.58 MHz		47.8	49		dB	
f = 16 MHz			48		dB	
Total Harmonic Distortion	THD					
f = 3.58 MHz			-62	-49.5	dB	
f = 16 MHz			-58		dB	
Spurious Free Dynamic Range	SFDR					
f = 3.58 MHz			66	51.4	dB	
f = 16 MHz			61		dB	
Differential Phase	DP		0.2		Degree	NTSC 40 IRE Mod Ramp
Differential Gain	DG		0.08		%	

Parameter	Symbol	Min	Typ	Max	Units	Condition
DIGITAL INPUTS						
High Input Voltage	V_{IH}	2.4			V	
Low Input Voltage	V_{IL}			0.3	V	
DIGITAL OUTPUTS						
High-Z Leakage	I_{OZ}	-10		+10	μA	Output = GND to VDD $C_L = 20 \text{ pF}$
Data Valid Delay	t_{OD}		25		ns	
Data Enable Delay	t_{DEN}		25		ns	
Data High-Z Delay	t_{DHZ}		13		ns	
LOGIC OUTPUT (with DRVDD = 3 V)						
High Level Output Voltage ($I_{OH} = 50 \mu A$)	V_{OH}	+2.95			V	
High Level Output Voltage ($I_{OH} = 0.5 \text{ mA}$)	V_{OH}	+2.80			V	
Low Level Output Voltage ($I_{OL} = 1.6 \text{ mA}$)	V_{OL}			+0.4	V	
Low Level Output Voltage ($I_{OL} = 50 \mu A$)	V_{OL}			+0.05	V	
LOGIC OUTPUT (with DRVDD = 5 V)						
High Level Output Voltage ($I_{OH} = 50 \mu A$)	V_{OH}	+4.5			V	
High Level Output Voltage ($I_{OH} = 0.5 \text{ mA}$)	V_{OH}	+2.4			V	
Low Level Output Voltage ($I_{OL} = 1.6 \text{ mA}$)	V_{OL}			+0.4	V	
Low Level Output Voltage ($I_{OL} = 50 \mu A$)	V_{OL}			+0.1	V	
CLOCKING						
Clock Pulsewidth High	t_{CH}	14.7			ns	
Clock Pulsewidth Low	t_{CL}	14.7			ns	
Pipeline Latency			3		Cycles	
CLAMP						
Clamp Error Voltage	E_{OC}		± 60	± 80	mV	CLAMPIN = +0.5 V to +2.0 V, $R_{IN} = 10 \Omega$ $C_{IN} = 1 \mu F$ (Period = 63.5 μs)
Clamp Pulsewidth	t_{CPW}		2		μs	

NOTES

¹See Figures 1a and 1b.

Specifications subject to change without notice.

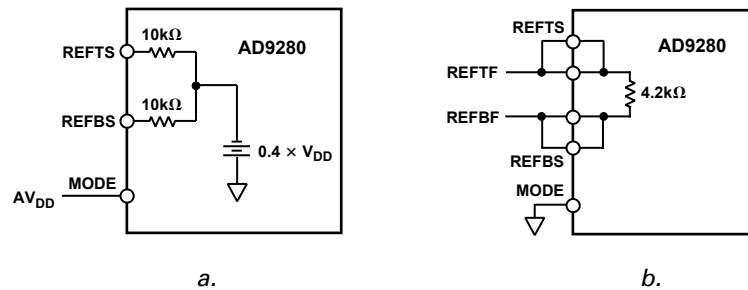

Figure 1. Equivalent Input Load

AD9280

ABSOLUTE MAXIMUM RATINGS*

Parameter	With Respect to	Min	Max	Units
AVDD	AVSS	-0.3	+6.5	V
DRVDD	DRVSS	-0.3	+6.5	V
AVSS	DRVSS	-0.3	+0.3	V
AVDD	DRVDD	-6.5	+6.5	V
MODE	AVSS	-0.3	AVDD + 0.3	V
CLK	AVSS	-0.3	AVDD + 0.3	V
Digital Outputs	DRVSS	-0.3	DRVDD + 0.3	V
AIN	AVSS	-0.3	AVDD + 0.3	V
VREF	AVSS	-0.3	AVDD + 0.3	V
REFSENSE	AVSS	-0.3	AVDD + 0.3	V
REFTF, REFTB	AVSS	-0.3	AVDD + 0.3	V
REFTS, REFTS	AVSS	-0.3	AVDD + 0.3	V
Junction Temperature			+150	°C
Storage Temperature		-65	+150	°C
Lead Temperature 10 sec			+300	°C

*Stresses above those listed under Absolute Maximum Ratings may cause permanent damage to the device. This is a stress rating only; functional operation of the device at these or any other conditions above those indicated in the operational sections of this specification is not implied. Exposure to absolute maximum ratings for extended periods may effect device reliability.

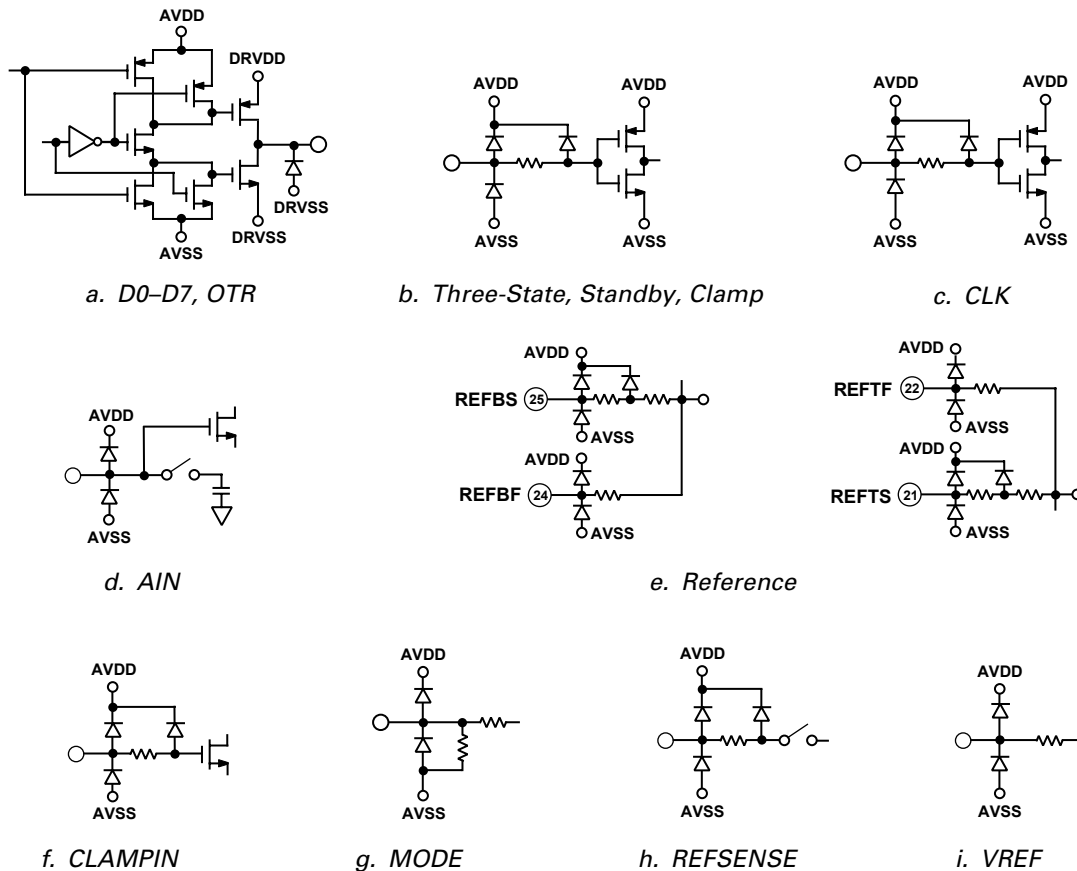

Figure 2. Equivalent Circuits

CAUTION

ESD (electrostatic discharge) sensitive device. Electrostatic charges as high as 4000 V readily accumulate on the human body and test equipment and can discharge without detection. Although the AD9280 features proprietary ESD protection circuitry, permanent damage may occur on devices subjected to high energy electrostatic discharges. Therefore, proper ESD precautions are recommended to avoid performance degradation or loss of functionality.



PIN CONFIGURATION
28-Lead Wide Body (SSOP)

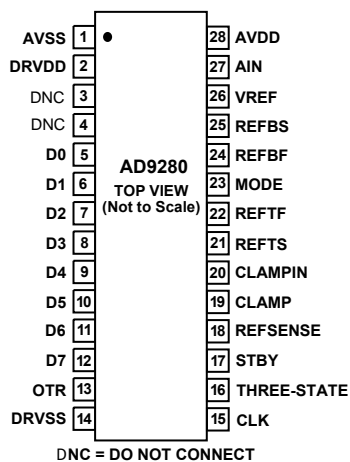

PIN FUNCTION DESCRIPTIONS

SSOP Pin No.	Name	Description
1	AVSS	Analog Ground
2	DRVDD	Digital Driver Supply
3	DNC	Do Not Connect
4	DNC	Do Not Connect
5	D0	Bit 0
6	D1	Bit 1
7	D2	Bit 2
8	D3	Bit 3
9	D4	Bit 4
10	D5	Bit 5
11	D6	Bit 6
12	D7	Bit 7, Most Significant Bit
13	OTR	Out-of-Range Indicator
14	DRVSS	Digital Ground
15	CLK	Clock Input
16	THREE-STATE	HI: High Impedance State. LO: Normal Operation
17	STBY	HI: Power-Down Mode. LO: Normal Operation
18	REFSENSE	Reference Select
19	CLAMP	HI: Enable Clamp Mode. LO: No Clamp
20	CLAMPIN	Clamp Reference Input
21	REFTS	Top Reference
22	REFTF	Top Reference Decoupling
23	MODE	Mode Select
24	REFBF	Bottom Reference Decoupling
25	REFBS	Bottom Reference
26	VREF	Internal Reference Output
27	AIN	Analog Input
28	AVDD	Analog Supply

AD9280

DEFINITIONS OF SPECIFICATIONS

Integral Nonlinearity (INL)

Integral nonlinearity refers to the deviation of each individual code from a line drawn from “zero” through “full scale.” The point used as “zero” occurs 1/2 LSB before the first code transition. “Full scale” is defined as a level 1 1/2 LSB beyond the last code transition. The deviation is measured from the center of each particular code to the true straight line.

Differential Nonlinearity (DNL, No Missing Codes)

An ideal ADC exhibits code transitions that are exactly 1 LSB apart. DNL is the deviation from this ideal value. It is often specified in terms of the resolution for which no missing codes (NMC) are guaranteed.

Offset Error

The first transition should occur at a level 1 LSB above “zero.” Offset is defined as the deviation of the actual first code transition from that point.

Gain Error

The first code transition should occur for an analog value 1 LSB above nominal negative full scale. The last transition should occur for an analog value 1 LSB below the nominal positive full scale. Gain error is the deviation of the actual difference between first and last code transitions and the ideal difference between the first and last code transitions.

Pipeline Delay (Latency)

The number of clock cycles between conversion initiation and the associated output data being made available. New output data is provided every rising edge.

Typical Characterization Curves

(AVDD = +3 V, DRVDD = +3 V, $F_S = 32$ MHz (50% Duty Cycle), MODE = AVDD, 2 V Input Span from 0.5 V to 2.5 V, External Reference, unless otherwise noted)

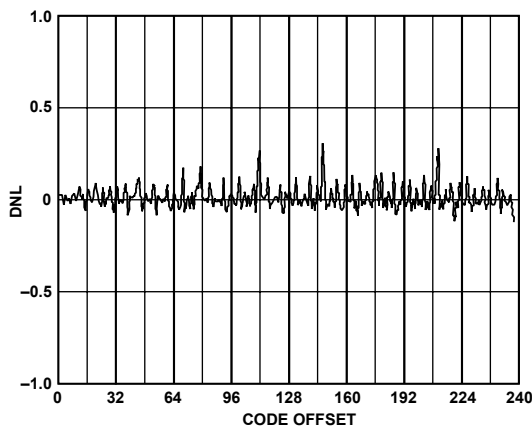

Figure 3. Typical DNL

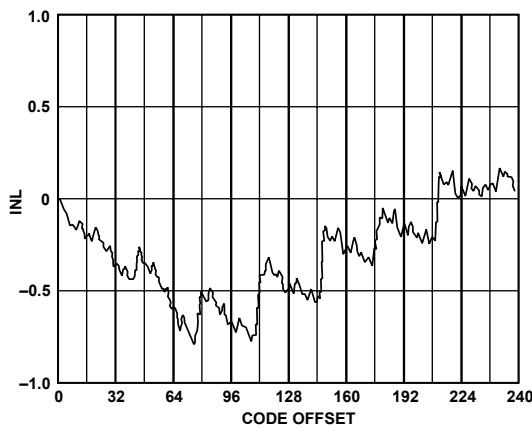

Figure 4. Typical INL

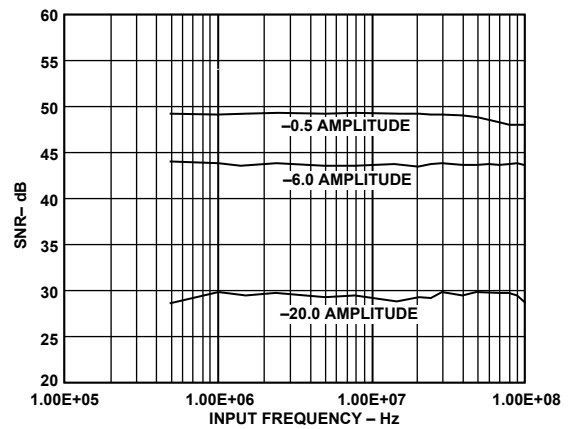

Figure 5. SNR vs. Input Frequency

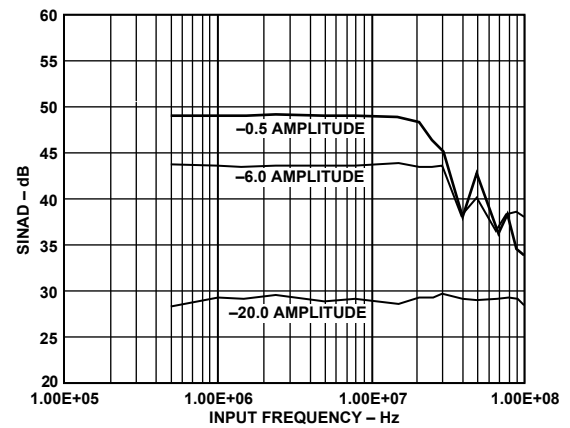

Figure 6. SINAD vs. Input Frequency

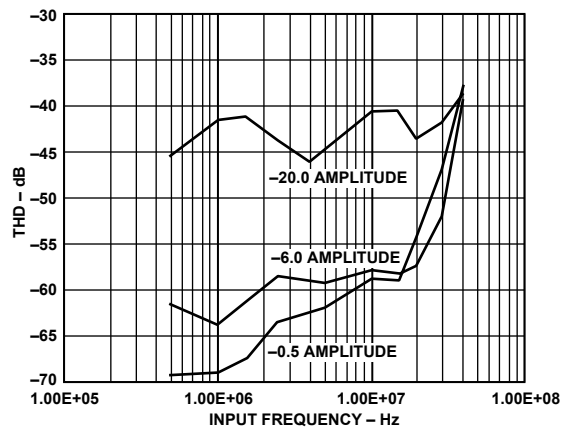

Figure 7. THD vs. Input Frequency

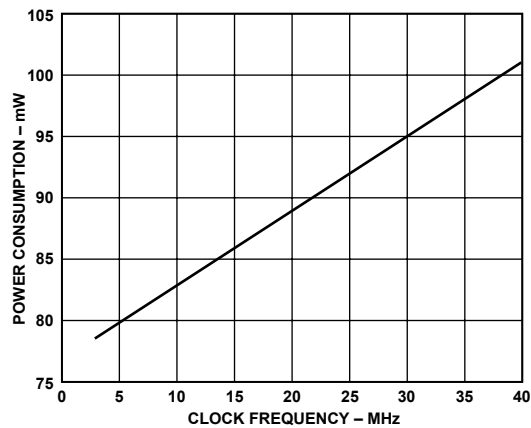

Figure 10. Power Consumption vs. Clock Frequency (MODE = AVSS)

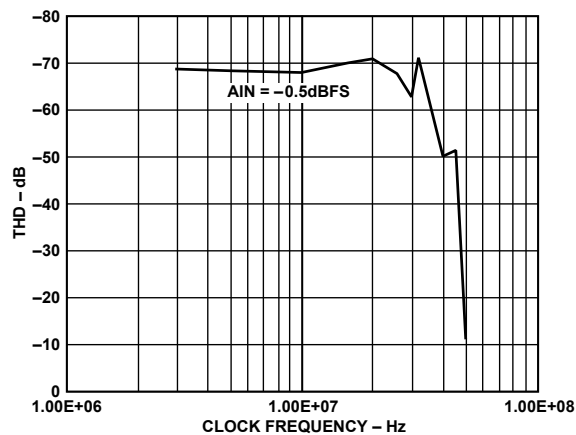

Figure 8. THD vs. Clock Frequency

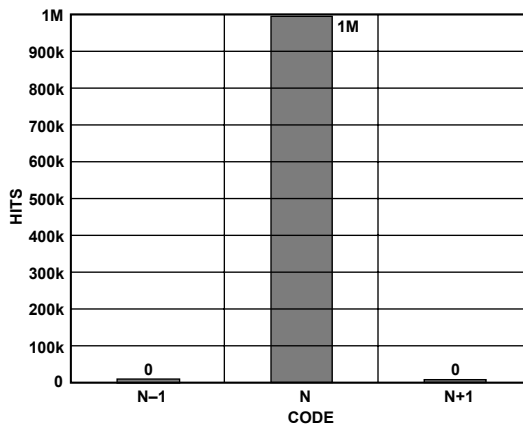

Figure 11. Grounded Input Histogram

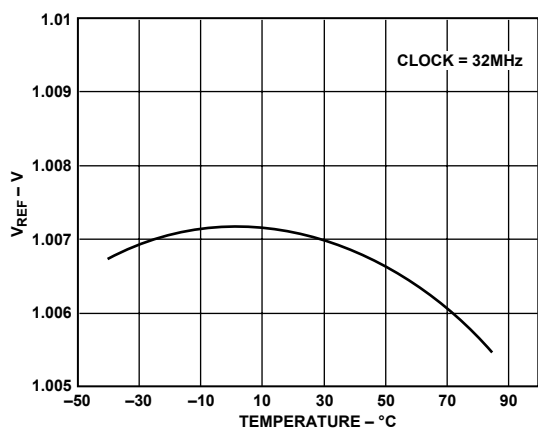

Figure 9. Voltage Reference Error vs. Temperature

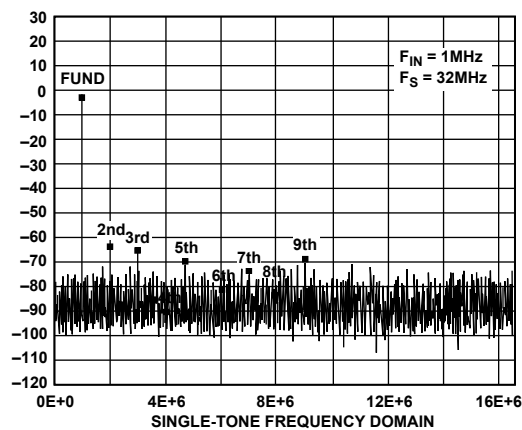

Figure 12. Single-Tone Frequency Domain

AD9280

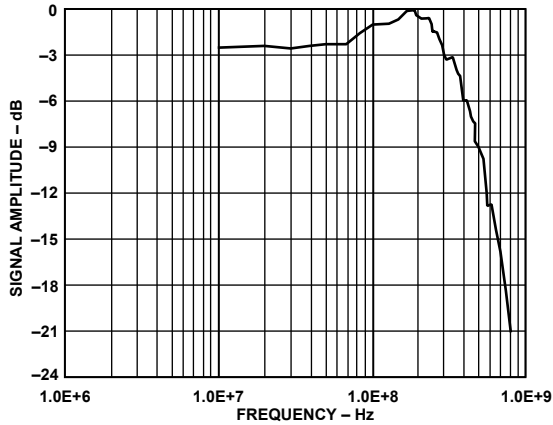

Figure 13. Full Power Bandwidth

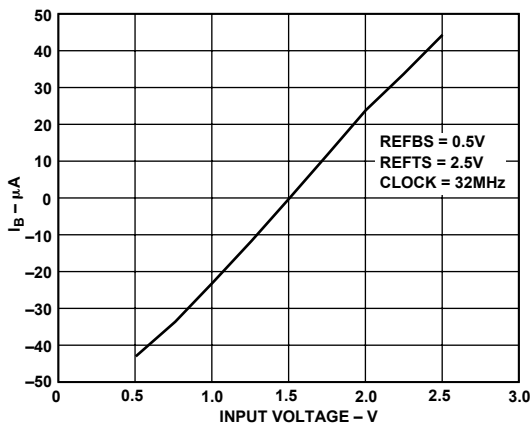

Figure 14. Input Bias Current vs. Input Voltage

APPLYING THE AD9280

THEORY OF OPERATION

The AD9280 implements a pipelined multistage architecture to achieve high sample rate with low power. The AD9280 distributes the conversion over several smaller A/D subblocks, refining the conversion with progressively higher accuracy as it passes the results from stage to stage. As a consequence of the distributed conversion, the AD9280 requires a small fraction of the 256 comparators used in a traditional flash type A/D. A sample-and-hold function within each of the stages permits the first stage to operate on a new input sample while the second, third and fourth stages operate on the three preceding samples.

OPERATIONAL MODES

The AD9280 is designed to allow optimal performance in a wide variety of imaging, communications and instrumentation applications, including pin compatibility with the AD876-8 A/D. To realize this flexibility, internal switches on the AD9280 are used to reconfigure the circuit into different modes. These modes are selected by appropriate pin strapping. There are three parts of the circuit affected by this modality: the voltage reference, the reference buffer, and the analog input. The nature of the application will determine which mode is appropriate: the descriptions in the following sections, as well as Table I should assist in selecting the desired mode.

Table I. Mode Selection

Modes	Input Connect	Input Span	MODE Pin	REFSENSE Pin	REF	REFTS	REFBS	Figure
TOP/BOTTOM	AIN	1 V	AVDD	Short REFSENSE, REFTS and VREF Together			AGND	18
	AIN	2 V	AVDD	AGND	Short REFTS and VREF Together		AGND	19
CENTER SPAN	AIN	1 V	AVDD/2	Short VREF and REFSENSE Together		AVDD/2	AVDD/2	20
	AIN	2 V	AVDD/2	AGND	No Connect	AVDD/2	AVDD/2	
Differential	AIN Is Input 1	1 V	AVDD/2	Short VREF and REFSENSE Together			AVDD/2	29
	REFTS and REFBS Are Shorted Together for Input 2	2 V	AVDD/2	AGND	No Connect	AVDD/2	AVDD/2	
External Ref	AIN	2 V max	AVDD	AVDD	No Connect	Span = REFTS - REFBS (2 V max)		21, 22
			AGND			Short to VREFTF	Short to VREFBF	
AD876-8	AIN	2 V	Float or AVSS	AVDD	No Connect	Short to VREFTF	Short to VREFBF	30

SUMMARY OF MODES

VOLTAGE REFERENCE

1 V Mode the internal reference may be set to 1 V by connecting REFSENSE and VREF together.

2 V Mode the internal reference may be set to 2 V by connecting REFSENSE to analog ground

External Divider Mode the internal reference may be set to a point between 1 V and 2 V by adding external resistors. See Figure 16f.

External Reference Mode enables the user to apply an external reference to REFTS, REFBS and VREF pins. This mode is attained by tying REFSENSE to VDD.

REFERENCE BUFFER

Center Span Mode midscale is set by shorting REFTS and REFBS together and applying the midscale voltage to that point. The MODE pin is set to AVDD/2. The analog input will swing about that midscale point.

Top/Bottom Mode sets the input range between two points. The two points are between 1 V and 2 V apart. The Top/Bottom Mode is enabled by tying the MODE pin to AVDD.

ANALOG INPUT

Differential Mode is attained by driving the AIN pin as one differential input, shorting REFTS and REFBS together and driving them as the second differential input. The MODE pin is tied to AVDD/2. Preferred mode for optimal distortion performance.

Single-Ended is attained by driving the AIN pin while the REFTS and REFBS pins are held at dc points. The MODE pin is tied to AVDD.

Single-Ended/Clamped (AC Coupled) the input may be clamped to some dc level by ac coupling the input. This is done by tying the CLAMPIN to some dc point and applying a pulse to the CLAMP pin. MODE pin is tied to AVDD.

SPECIAL

AD876-8 Mode enables users of the AD876-8 to drop the AD9280 into their socket. This mode is attained by floating or grounding the MODE pin.

INPUT AND REFERENCE OVERVIEW

Figure 16, a simplified model of the AD9280, highlights the relationship between the analog input, AIN, and the reference voltages, REFTS, REFBS and VREF. Like the voltages applied to the resistor ladder in a flash A/D converter, REFTS and REFBS define the maximum and minimum input voltages to the A/D.

The input stage is normally configured for single-ended operation, but allows for differential operation by shorting REFTS and REFBS together to be used as the second input.

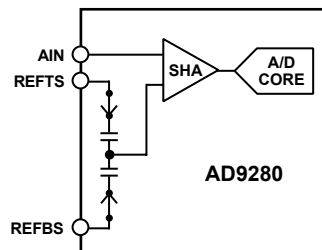

Figure 15. AD9280 Equivalent Functional Input Circuit

In single-ended operation, the input spans the range,

$$REFBS \leq AIN \leq REFTS$$

where REFBS can be connected to GND and REFTS connected to VREF. If the user requires a different reference range, REFBS and REFTS can be driven to any voltage within the power supply rails, so long as the difference between the two is between 1 V and 2 V.

In differential operation, REFTS and REFBS are shorted together, and the input span is set by VREF,

$$(REFTS - VREF/2) \leq AIN \leq (REFTS + VREF/2)$$

where VREF is determined by the internal reference or brought in externally by the user.

The best noise performance may be obtained by operating the AD9280 with a 2 V input range. The best distortion performance may be obtained by operating the AD9280 with a 1 V input range.

REFERENCE OPERATION

The AD9280 can be configured in a variety of reference topologies. The simplest configuration is to use the AD9280's onboard bandgap reference, which provides a pin-strappable option to generate either a 1 V or 2 V output. If the user desires a reference voltage other than those two, an external resistor divider can be connected between VREF, REFSENSE and analog ground to generate a potential anywhere between 1 V and 2 V. Another alternative is to use an external reference for designs requiring enhanced accuracy and/or drift performance. A third alternative is to bring in top and bottom references, bypassing VREF altogether.

Figures 16d, 16e and 16f illustrate the reference and input architecture of the AD9280. In tailoring a desired arrangement, the user can select an input configuration to match drive circuit. Then, moving to the reference modes at the bottom of the figure, select a reference circuit to accommodate the offset and amplitude of a full-scale signal.

Table I outlines pin configurations to match user requirements.

AD9280

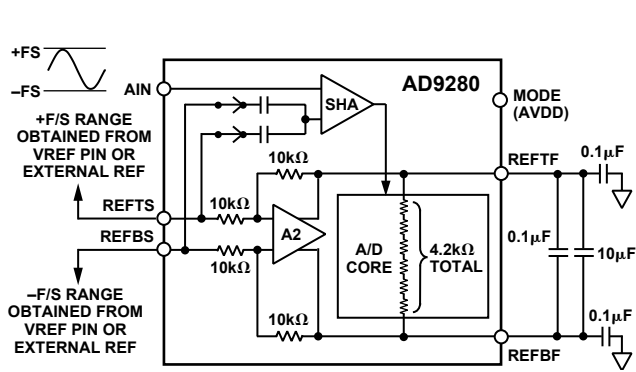

a. Top/Bottom Mode

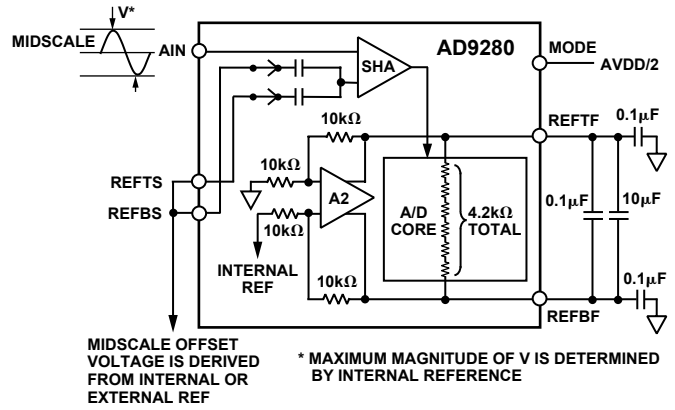

b. Center Span Mode

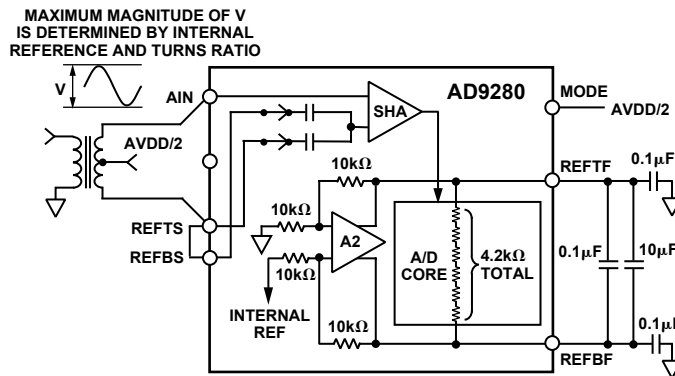

c. Differential Mode

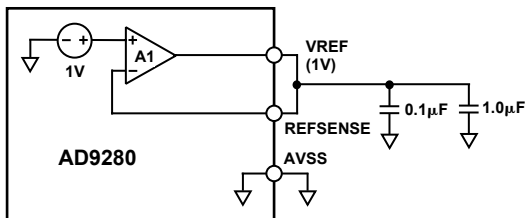

d. 1 V Reference

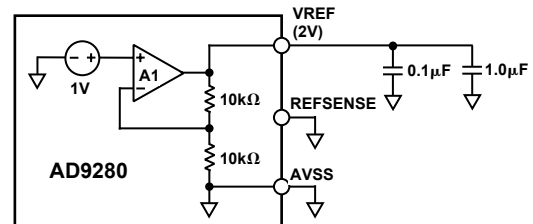

e. 2 V Reference

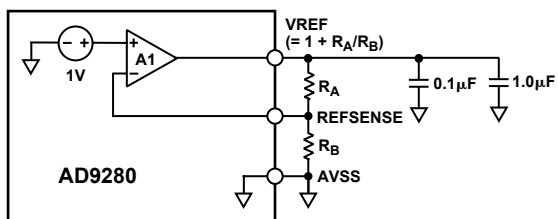

INTERNAL 10K REF RESISTORS ARE SWITCHED OPEN BY THE PRESENCE OF RA AND RB.

f. Variable Reference (Between 1 V and 2 V)

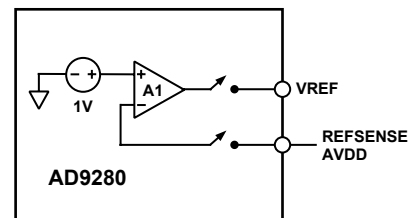

g. Internal Reference Disable (Power Reduction)

Figure 16.

The actual reference voltages used by the internal circuitry of the AD9280 appear on REFTF and REFBF. For proper operation, it is necessary to add a capacitor network to decouple these pins. The REFTF and REFBF should be decoupled for all internal and external configurations as shown in Figure 17.

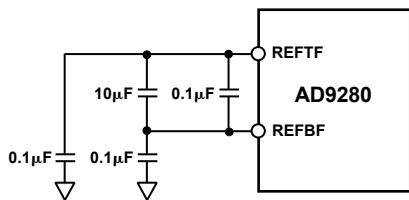

Figure 17. Reference Decoupling Network

Note: REFTF = reference top, force
 REFBF = reference bottom, force
 REFTS = reference top, sense
 REFBS = reference bottom, sense

INTERNAL REFERENCE OPERATION

Figures 18, 19 and 20 show sample connections of the AD9280 internal reference in its most common configurations. (Figures 18 and 19 illustrate top/bottom mode while Figure 20 illustrates center span mode). Figure 29 shows how to connect the AD9280 for 1 V p-p differential operation. Shorting the VREF pin directly to the REFSENSE pin places the internal reference amplifier, A1, in unity-gain mode and the resultant reference output is 1 V. In Figure 18 REFBS is grounded to give an input range from 0 V to 1 V. These modes can be chosen when the supply is either +3 V or +5 V. The VREF pin must be bypassed to AVSS (analog ground) with a 1.0 µF tantalum capacitor in parallel with a low inductance, low ESR, 0.1 µF ceramic capacitor.

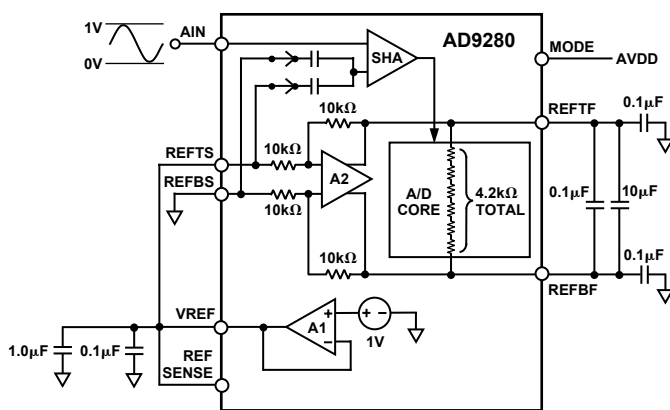

Figure 18. Internal Reference—1 V p-p Input Span (Top/Bottom Mode)

Figure 19 shows the single-ended configuration for 2 V p-p operation. REFSENSE is connected to GND, resulting in a 2 V reference output.

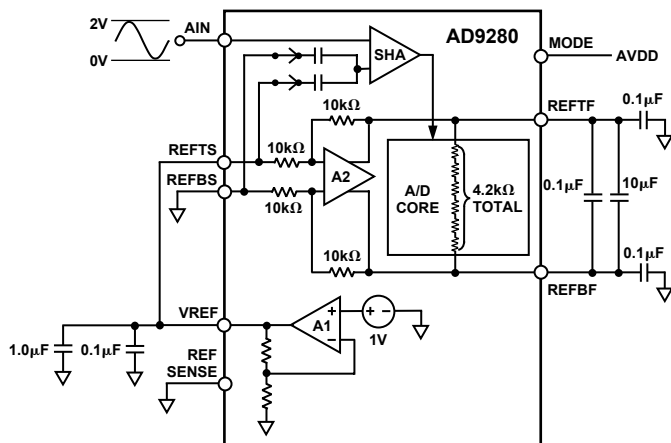

Figure 19. Internal Reference, 2 V p-p Input Span (Top/Bottom Mode)

Figure 20 shows the single-ended configuration that gives the good high frequency dynamic performance (SINAD, SFDR). To optimize dynamic performance, center the common-mode voltage of the analog input at approximately 1.5 V. Connect the shorted REFTS and REFBS inputs to a low impedance 1.5 V source. In this configuration, the MODE pin is driven to a voltage at midsupply (AVDD/2).

Maximum reference drive is 1 mA. An external buffer is required for heavier loads.

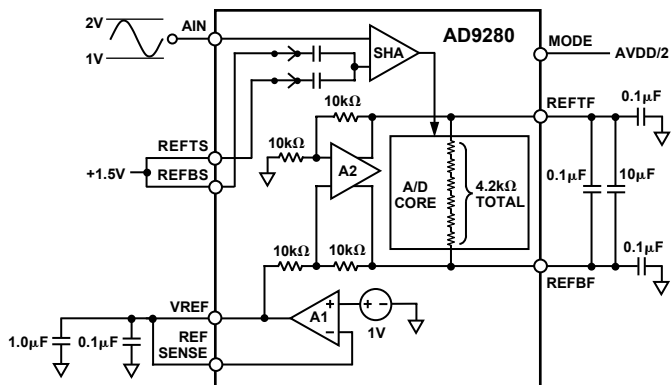

Figure 20. Internal Reference 1 V p-p Input Span (Center Span Mode)

AD9280

EXTERNAL REFERENCE OPERATION

Using an external reference may provide more flexibility and improve drift and accuracy. Figures 21 through 23 show examples of how to use an external reference with the AD9280. To use an external reference, the user must disable the internal reference amplifier by connecting the REFSENSE pin to VDD. The user then has the option of driving the VREF pin, or driving the REFTS and REFBS pins.

The AD9280 contains an internal reference buffer (A2), that simplifies the drive requirements of an external reference. The external reference must simply be able to drive a 10 kΩ load.

Figure 21 shows an example of the user driving the top and bottom references. REFTS is connected to a low impedance 2 V source and REFBS is connected to a low impedance 1 V source. REFTS and REFBS may be driven to any voltage within the supply as long as the difference between them is between 1 V and 2 V.

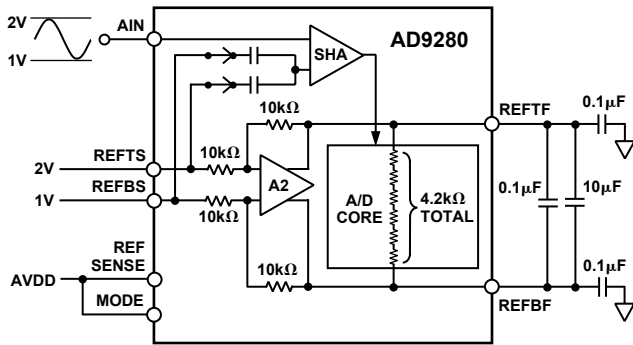

Figure 21. External Reference Mode—1 V p-p Input Span

Figure 22 shows an example of an external reference generating 2.5 V at the shorted REFTS and REFBS inputs. In this instance, a REF43 2.5 V reference drives REFTS and REFBS. A resistive divider generates a 1 V VREF signal that is buffered by A3. A3 must be able to drive a 10 kΩ, capacitive load. Choose this op amp based on noise and accuracy requirements.

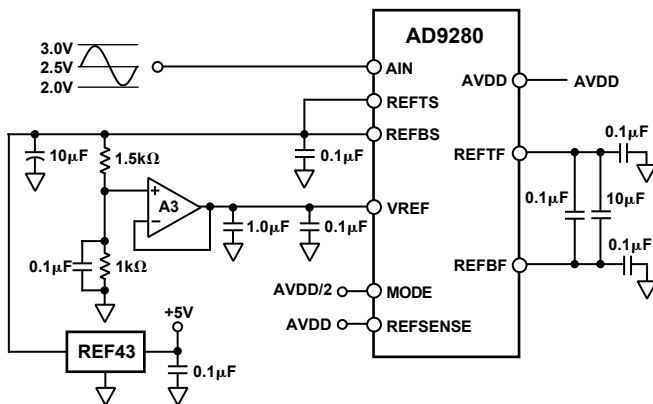

Figure 22. External Reference Mode—1 V p-p Input Span 2.5 V_{CM}

Figure 23a shows an example of the external references driving the REFTF and REFBF pins that is compatible with the AD876. REFTS is shorted to REFTF and driven by an external 4 V low impedance source. REFBS is shorted to REFBF and driven by a 2 V source. The MODE pin is connected to GND in this configuration.

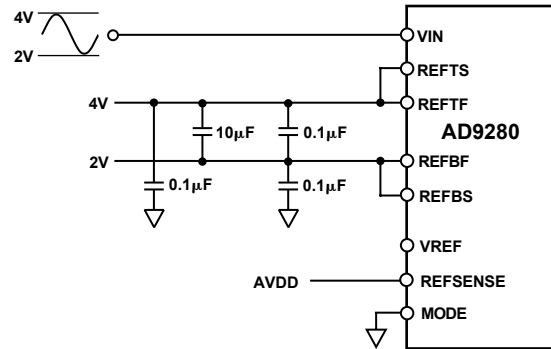

Figure 23a. External Reference—2 V p-p Input Span

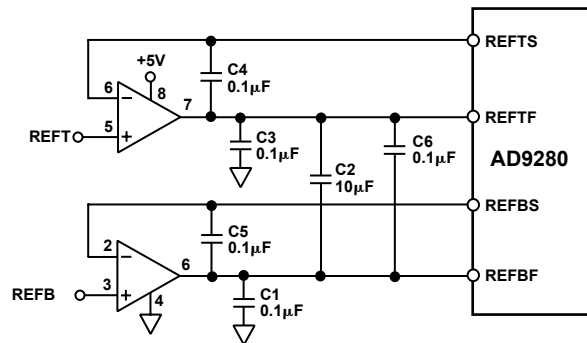

Figure 23b. Kelvin Connected Reference Using the AD9280

STANDBY OPERATION

The ADC may be placed into a powered down (sleep) mode by driving the STBY (standby) pin to logic high potential and holding the clock at logic low. In this mode the typical power drain is approximately 4 mW.

The ADC will “wake up” in 400 ns (typ) after the standby pulse goes low.

CLAMP OPERATION

The AD9280ARS features an optional clamp circuit for dc restoration of video or ac coupled signals. Figure 24 shows the internal clamp circuitry and the external control signals needed for clamp operation. To enable the clamp, apply a logic high to the CLAMP pin. This will close the switch SW1. The clamp amplifier will then servo the voltage at the AIN pin to be equal to the clamp voltage applied at the CLAMPIN pin. After the desired clamp level is attained, SW1 is opened by taking CLAMP back to a logic low. Ignoring the droop caused by the input bias current, the input capacitor C_{IN} will hold the dc voltage at AIN constant until the next clamp interval. The input resistor R_{IN} has a minimum recommended value of 10 Ω, to maintain the closed-loop stability of the clamp amplifier.

The allowable voltage range that can be applied to CLAMPIN depends on the operational limits of the internal clamp amplifier. The recommended clamp range is between 0.5 volts and 2.0 volts.

The input capacitor should be sized to allow sufficient acquisition time of the clamp voltage at AIN within the CLAMP interval, but also be sized to minimize droop between clamping intervals. Specifically, the acquisition time when the switch is closed will equal:

$$T_{ACQ} = R_{IN}C_{IN} \ln\left(\frac{V_C}{V_E}\right)$$

where V_C is the voltage change required across C_{IN} , and V_E is the error voltage. V_C is calculated by taking the difference between the initial input dc level at the start of the clamp interval and the clamp voltage supplied at CLAMPIN. V_E is a system dependent parameter, and equals the maximum tolerable deviation from V_C . For example, if a 2-volt input level needs to be clamped to 1 volt at the AD9280's input within 10 millivolts, then V_C equals 2 – 1 or 1 volt, and V_E equals 10 mV. Note that once the proper clamp level is attained at the input, only a very small voltage change will be required to correct for droop.

The voltage droop is calculated with the following equation:

$$dV = \frac{I_{BIAS}}{C_{IN}}(t)$$

where t = time between clamping intervals.

The bias current of the AD9280 will depend on the sampling rate, F_S , and the difference between the reference midpoint, $(REFTS-REFBS)/2$ and the input voltage. For a fixed sampling rate of 32 MHz, Figure 14 shows the input bias current for a given input. For a 1 V input range, the maximum input bias current from Figure 14 is 22 μ A. For lower sampling rates the input bias current will scale proportionally.

If droop is a critical parameter, then the minimum value of C_{IN} should be calculated first based on the droop requirement. Acquisition time—the width of the CLAMP pulse—can be adjusted accordingly once the minimum capacitor value is chosen. A tradeoff will often need to be made between droop and acquisition time, or error voltage V_E .

Clamp Circuit Example

A single supply video amplifier outputs a level-shifted video signal between 2 and 3 volts with the following parameters:

- horizontal period = 63.56 μ s,
- horizontal sync interval = 10.9 μ s,
- horizontal sync pulse = 4.7 μ s,
- sync amplitude = 0.3 volts,
- video amplitude of 0.7 volts,
- reference black level = 2.3 volts

The video signal must be dc restored from a 2- to 3-volt range down to a 1- to 2-volt range. Configuring the AD9280 for a one volt input span with an input range from 1 to 2 volts (see Figure 24), the CLAMPIN voltage can be set to 1 volt with an external voltage or by direct connection to REFBS. The CLAMP pulse may be applied during the SYNC pulse, or during the

back porch to truncate the SYNC below the AD9280's minimum input voltage. With a $C_{IN} = 1 \mu$ F, and $R_{IN} = 20 \Omega$, the acquisition time needed to set the input dc level to one volt with 1 mV accuracy is about 140 μ s, assuming a full 1 volt V_C .

With a 1 μ F input coupling capacitor, the droop across one horizontal can be calculated:

$I_{BIAS} = 22 \mu$ A, and $t = 63.5 \mu$ s, so $dV = 1.397$ mV, which is less than one LSB.

After the input capacitor is initially charged, the clamp pulse width only needs to be wide enough to correct small voltage errors such as the droop. The fine scale settling characteristics of the clamp circuitry are shown in Table II.

Depending on the required accuracy, a CLAMP pulse width of 1 μ s–3 μ s should work in most applications. The OFFSET values ignore the contribution of offset from the clamp amplifier; they simply compare the output code with a “final value” measured with a much longer CLAMP pulse duration.

Table II.

CLAMP	OFFSET
8 μ s	<1 LSB
4 μ s	<2 LSBs
3 μ s	2 LSBs
2 μ s	5 LSBs
1 μ s	9 LSBs

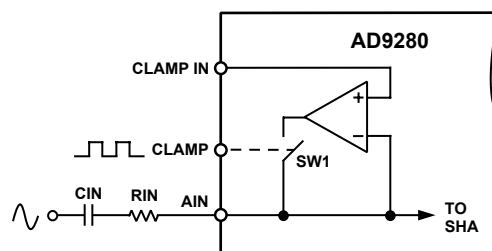

Figure 24a. Clamp Operation

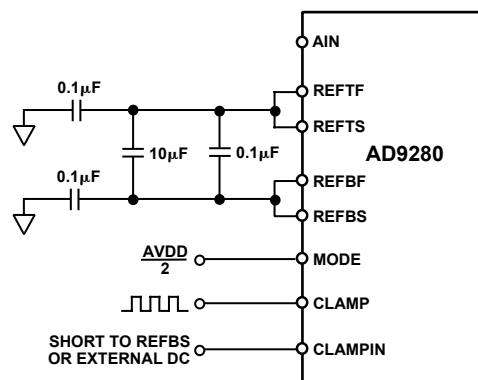

Figure 24b. Video Clamp Circuit

AD9280

DRIVING THE ANALOG INPUT

Figure 25 shows the equivalent analog input of the AD9280, a sample-and-hold amplifier (switched capacitor input SHA). Bringing CLK to a logic low level closes Switches 1 and 2 and opens Switch 3. The input source connected to AIN must charge capacitor CH during this time. When CLK transitions from logic “low” to logic “high,” Switches 1 and 2 open, placing the SHA in hold mode. Switch 3 then closes, forcing the output of the op amp to equal the voltage stored on CH. When CLK transitions from logic “high” to logic “low,” Switch 3 opens first. Switches 1 and 2 close, placing the SHA in track mode.

The structure of the input SHA places certain requirements on the input drive source. The combination of the pin capacitance, CP, and the hold capacitance, CH, is typically less than 5 pF. The input source must be able to charge or discharge this capacitance to 8-bit accuracy in one half of a clock cycle. When the SHA goes into track mode, the input source must charge or discharge capacitor CH from the voltage already stored on CH to the new voltage. In the worst case, a full-scale voltage step on the input, the input source must provide the charging current through the R_{ON} (50 Ω) of Switch 1 and quickly (within 1/2 CLK period) settle. This situation corresponds to driving a low input impedance. On the other hand, when the source voltage equals the value previously stored on CH, the hold capacitor requires no input current and the equivalent input impedance is extremely high.

Adding series resistance between the output of the source and the AIN pin reduces the drive requirements placed on the source. Figure 26 shows this configuration. The bandwidth of the particular application limits the size of this resistor. To maintain the performance outlined in the data sheet specifications, the resistor should be limited to 20 Ω or less. For applications with signal bandwidths less than 16 MHz, the user may proportionally increase the size of the series resistor. Alternatively, adding a shunt capacitance between the AIN pin and analog ground can lower the ac load impedance. The value of this capacitance will depend on the source resistance and the required signal bandwidth.

The input span of the AD9280 is a function of the reference voltages. For more information regarding the input range, see the Internal and External Reference sections of the data sheet.

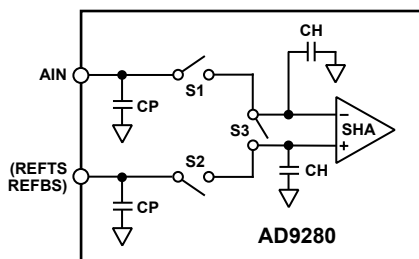

Figure 25. AD9280 Equivalent Input Structure

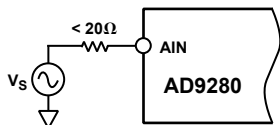

Figure 26. Simple AD9280 Drive Configuration

In many cases, particularly in single-supply operation, ac coupling offers a convenient way of biasing the analog input signal at the proper signal range. Figure 27 shows a typical configuration for ac-coupling the analog input signal to the AD9280. Maintaining the specifications outlined in the data sheet requires careful selection of the component values. The most important is the $f_{-3\text{ dB}}$ high-pass corner frequency. It is a function of R2 and the parallel combination of C1 and C2. The $f_{-3\text{ dB}}$ point can be approximated by the equation:

$$f_{-3\text{ dB}} = 1/(2 \times \pi \times [R2] C_{EQ})$$

where C_{EQ} is the parallel combination of C1 and C2. Note that C1 is typically a large electrolytic or tantalum capacitor that becomes inductive at high frequencies. Adding a small ceramic or polystyrene capacitor (on the order of 0.01 μF) that does not become inductive until negligibly higher frequencies, maintains a low impedance over a wide frequency range.

NOTE: AC coupled input signals may also be shifted to a desired level with the AD9280's internal clamp. See Clamp Operation.

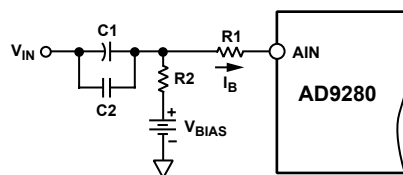

Figure 27. AC Coupled Input

There are additional considerations when choosing the resistor values. The ac-coupling capacitors integrate the switching transients present at the input of the AD9280 and cause a net dc bias current, I_B , to flow into the input. The magnitude of the bias current increases as the signal magnitude deviates from V midscale and the clock frequency increases; i.e., minimum bias current flow when $A_{IN} = V$ midscale. This bias current will result in an offset error of $(R1 + R2) \times I_B$. If it is necessary to compensate this error, consider making R2 negligibly small or modifying VBIAS to account for the resultant offset.

In systems that must use dc coupling, use an op amp to level-shift a ground-referenced signal to comply with the input requirements of the AD9280. Figure 28 shows an AD8041 configured in noninverting mode.

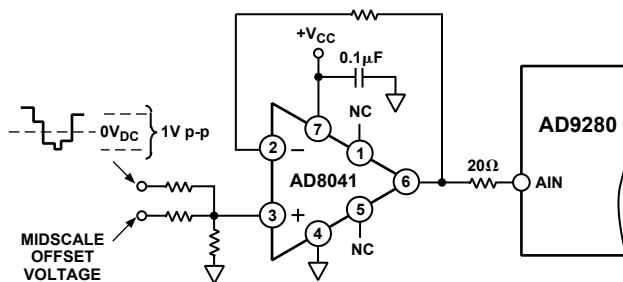

Figure 28. Bipolar Level Shift

DIFFERENTIAL INPUT OPERATION

The AD9280 will accept differential input signals. This function may be used by shorting REFTS and REFBS and driving them as one leg of the differential signal (the top leg is driven into AIN). In the configuration below, the AD9280 is accepting a 1 V p-p signal. See Figure 29.

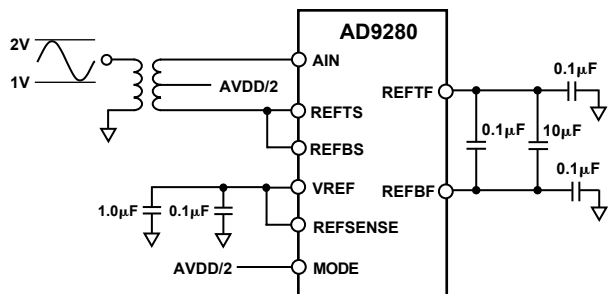

Figure 29. Differential Input

AD876-8 MODE OF OPERATION

The AD9280 may be dropped into the AD876-8 socket. This will allow AD876-8 users to take advantage of the reduced power consumption realized when running the AD9280 on a 3.0 V analog supply.

Figure 30 shows the pin functions of the AD876-8 and AD9280. The grounded REFSense pin and floating MODE pin effectively put the AD9280 in the external reference mode. The external reference input for the AD876-8 will now be placed on the reference pins of the AD9280.

The clamp controls will be grounded by the AD876-8 socket. The AD9280 has a 3 clock cycle delay compared to a 3.5 cycle delay of the AD876-8.

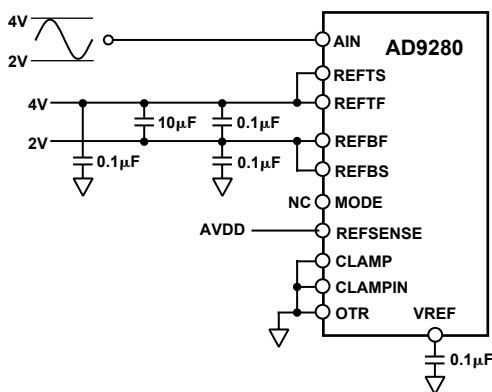

Figure 30. AD876 Mode

CLOCK INPUT

The AD9280 clock input is buffered internally with an inverter powered from the AVDD pin. This feature allows the AD9280 to accommodate either +5 V or +3.3 V CMOS logic input signal swings with the input threshold for the CLK pin nominally at AVDD/2.

The pipelined architecture of the AD9280 operates on both rising and falling edges of the input clock. To minimize duty cycle variations the recommended logic family to drive the clock input is high speed or advanced CMOS (HC/HCT, AC/ACT) logic. CMOS logic provides both symmetrical voltage threshold levels and sufficient rise and fall times to support 32 MSPS operation. The AD9280 is designed to support a conversion rate of 32 MSPS; running the part at slightly faster clock rates may be possible, although at reduced performance levels. Conversely, some slight performance improvements might be realized by clocking the AD9280 at slower clock rates.

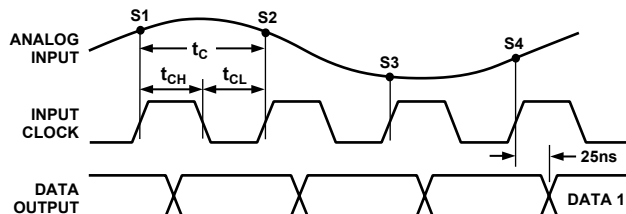

Figure 31. Timing Diagram

The power dissipated by the output buffers is largely proportional to the clock frequency; running at reduced clock rates provides a reduction in power consumption.

DIGITAL INPUTS AND OUTPUTS

Each of the AD9280 digital control inputs, THREE-STATE and STBY are reference to analog ground. The clock is also referenced to analog ground.

The format of the digital output is straight binary (see Figure 32). A low power mode feature is provided such that for STBY = HIGH and the clock disabled, the static power of the AD9280 will drop below 5 mW.

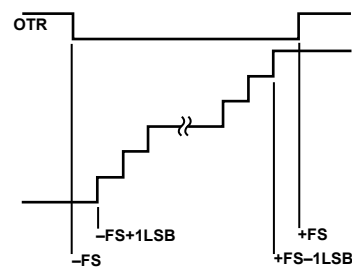

Figure 32. Output Data Format

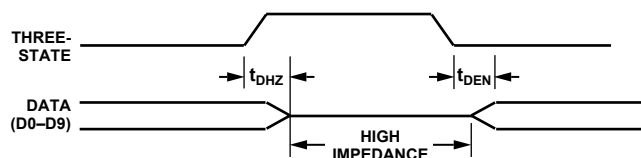

Figure 33. Three-State Timing Diagram

AD9280

APPLICATIONS

DIRECT IF DOWN CONVERSION USING THE AD9280

Sampling IF signals above an ADC's baseband region (i.e., dc to $F_S/2$) is becoming increasingly popular in communication applications. This process is often referred to as Direct IF Down Conversion or Undersampling. There are several potential benefits in using the ADC to alias (i.e., or mix) down a narrowband or wideband IF signal. First and foremost is the elimination of a complete mixer stage with its associated amplifiers and filters, reducing cost and power dissipation. Second is the ability to apply various DSP techniques to perform such functions as filtering, channel selection, quadrature demodulation, data reduction, detection, etc. A detailed discussion on using this technique in digital receivers can be found in Analog Devices Application Notes AN-301 and AN-302.

In Direct IF Down Conversion applications, one exploits the inherent sampling process of an ADC in which an IF signal lying outside the baseband region can be aliased back into the baseband region in a similar manner that a mixer will down-convert an IF signal. Similar to the mixer topology, an image rejection filter is required to limit other potential interfering signals from also aliasing back into the ADC's baseband region. A tradeoff exists between the complexity of this image rejection filter and the sample rate as well as dynamic range of the ADC.

The AD9280 is well suited for various narrowband IF sampling applications. The AD9280's low distortion input SHA has a full-power bandwidth extending to 300 MHz thus encompassing many popular IF frequencies. The AD9280 will typically yield an improvement in SNR when configured for the 2 V span, the 1 V span provides the optimum full-scale distortion performance. Furthermore, the 1 V span reduces the performance requirements of the input driver circuitry and thus may be more practical for system implementation purposes.

Figure 34 shows a simplified schematic of the AD9280 configured in an IF sampling application. To reduce the complexity of the digital demodulator in many quadrature demodulation applications, the IF frequency and/or sample rate are selected such

that the bandlimited IF signal aliases back into the center of the ADC's baseband region (i.e., $F_S/4$). For example, if an IF signal centered at 45 MHz is sampled at 20 MSPS, an image of this IF signal will be aliased back to 5.0 MHz which corresponds to one quarter of the sample rate (i.e., $F_S/4$). This demodulation technique typically reduces the complexity of the post digital demodulator ASIC which follows the ADC.

To maximize its distortion performance, the AD9280 is configured in the differential mode with a 1 V span using a transformer. The center tap of the transformer is biased at midsupply via a resistor divider. Preceding the AD9280 is a bandpass filter as well as a 32 dB gain stage. A large gain stage may be required to compensate for the high insertion losses of a SAW filter used for image rejection. The gain stage will also provide adequate isolation for the SAW filter from the charge "kick back" currents associated with AD9280's input stage.

The gain stage can be realized using one or two cascaded AD8009 op amps amplifiers. The AD8009 is a low cost, 1 GHz, current-feedback op amp having a 3rd order intercept characterized up to 250 MHz. A passive bandpass filter following the AD8009 attenuates its dominant 2nd order distortion products which would otherwise be aliased back into the AD9280's baseband region. Also, it reduces any out-of-band noise which would also be aliased back due to the AD9280's noise bandwidth of 220+ MHz. Note, the bandpass filters specifications are application dependent and will affect both the total distortion and noise performance of this circuit.

The distortion and noise performance of an ADC at the given IF frequency is of particular concern when evaluating an ADC for a narrowband IF sampling application. Both single-tone and dual-tone SFDR vs. amplitude are very useful in assessing an ADC's noise performance and noise contribution due to aperture jitter. In any application, one is advised to test several units of the same device under the same conditions to evaluate the given applications sensitivity to that particular device.

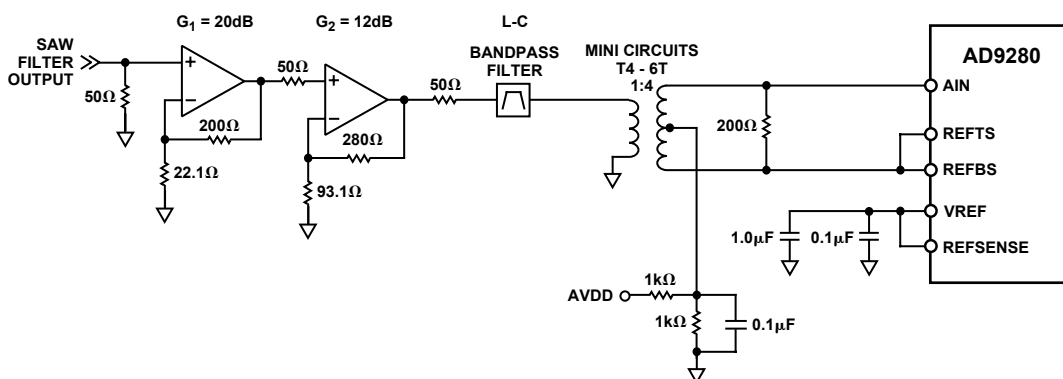

Figure 34. Simplified AD9280 IF Sampling Circuit

Figures 35–38 combine the dual-tone SFDR as well as single tone SFDR and SNR performance at IF frequencies of 45 MHz, 70 MHz, 85 MHz and 135 MHz. Note, the SFDR vs. amplitude data is referenced to dBFS while the single tone SNR data is referenced to dBc. The AD9280 was operated in the differential mode (via transformer) with a 1 V span. The analog supply (AVDD) and the digital supply (DRVDD) were set to +5 V and 3.3 V, respectively.

is referenced to dBc. The AD9280 was operated in the differential mode (via transformer) with a 1 V span. The analog supply (AVDD) and the digital supply (DRVDD) were set to +5 V and 3.3 V, respectively.

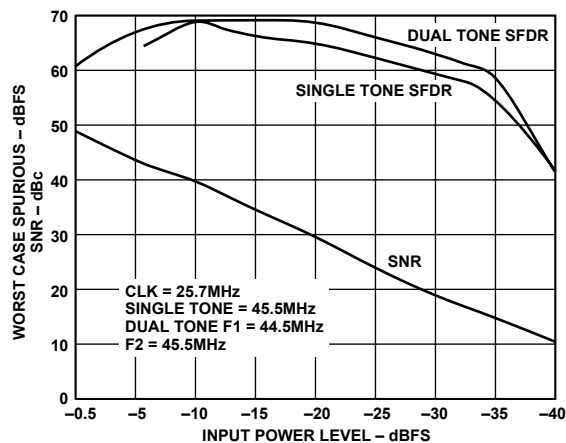

Figure 35. SNR/SFDR for IF @ 45 MHz

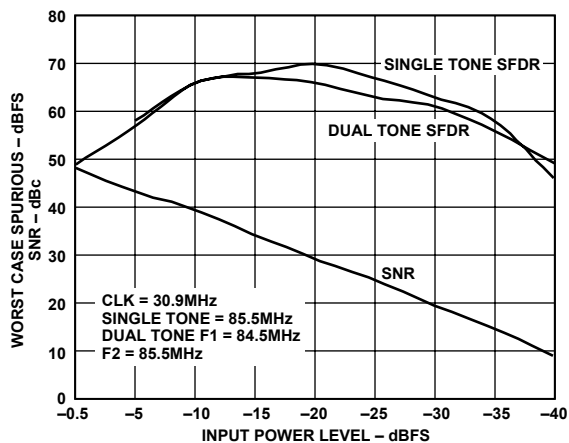

Figure 37. SNR/SFDR for IF @ 85 MHz

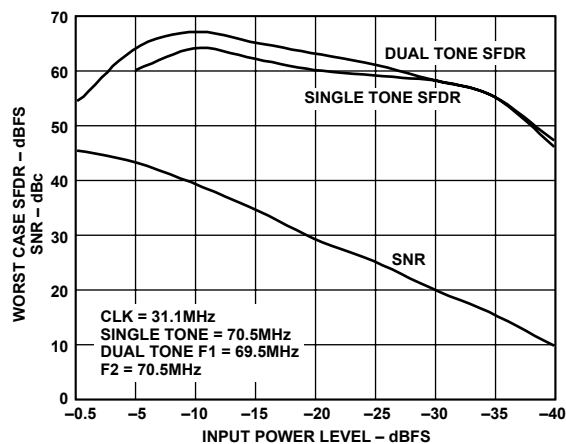

Figure 36. SNR/SFDR for IF @ 70 MHz

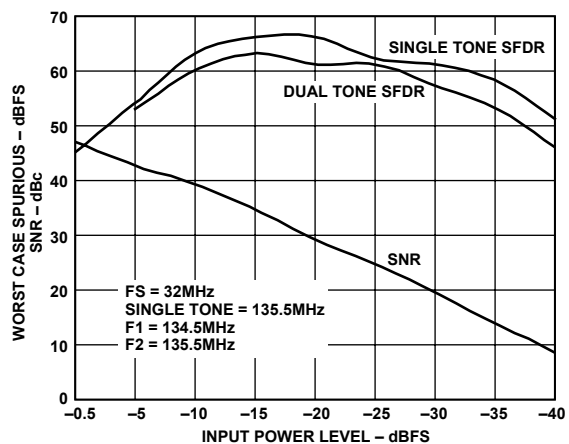

Figure 38. SNR/SFDR for IF @ 135 MHz

AD9280

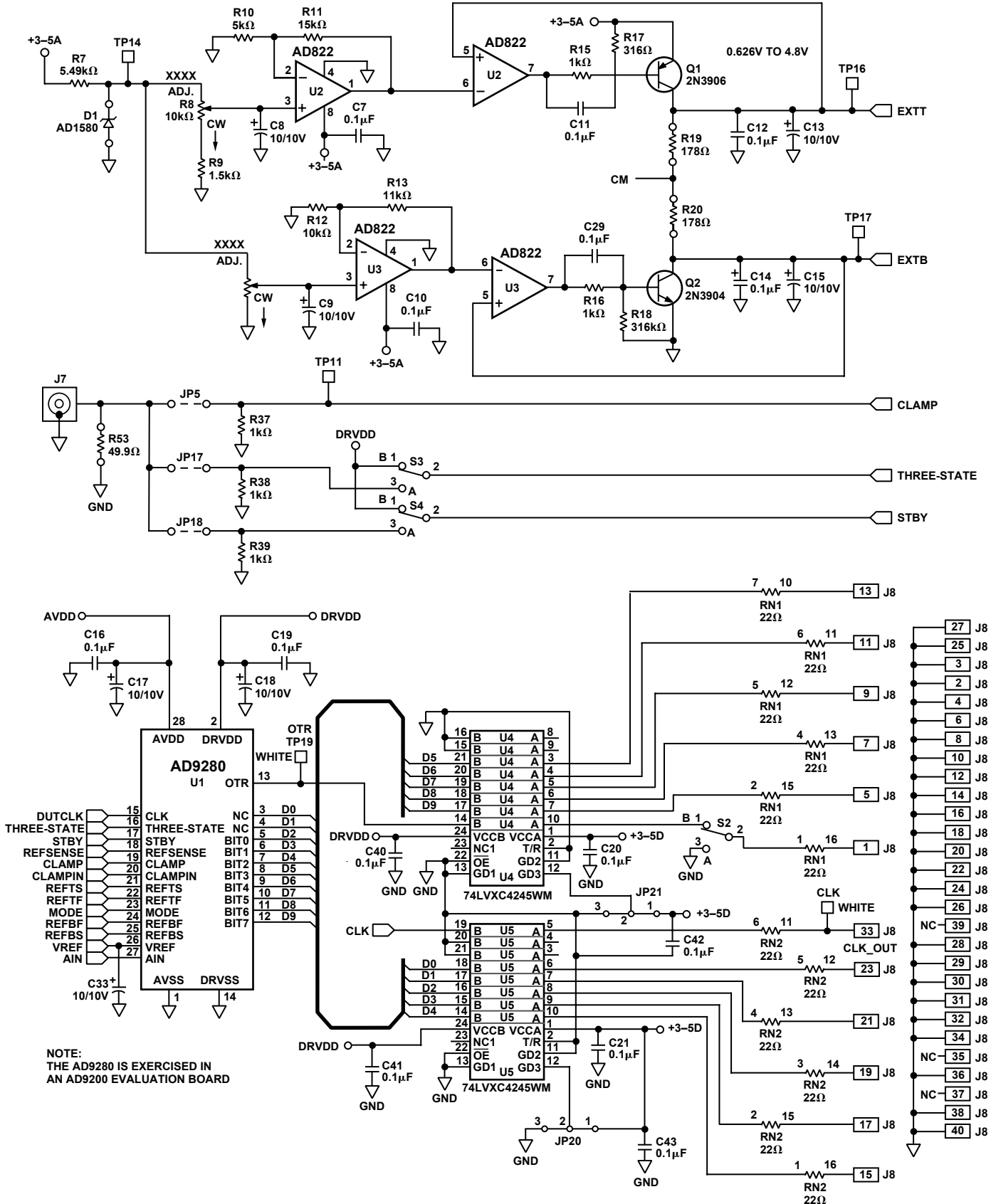

Figure 39a. Evaluation Board Schematic

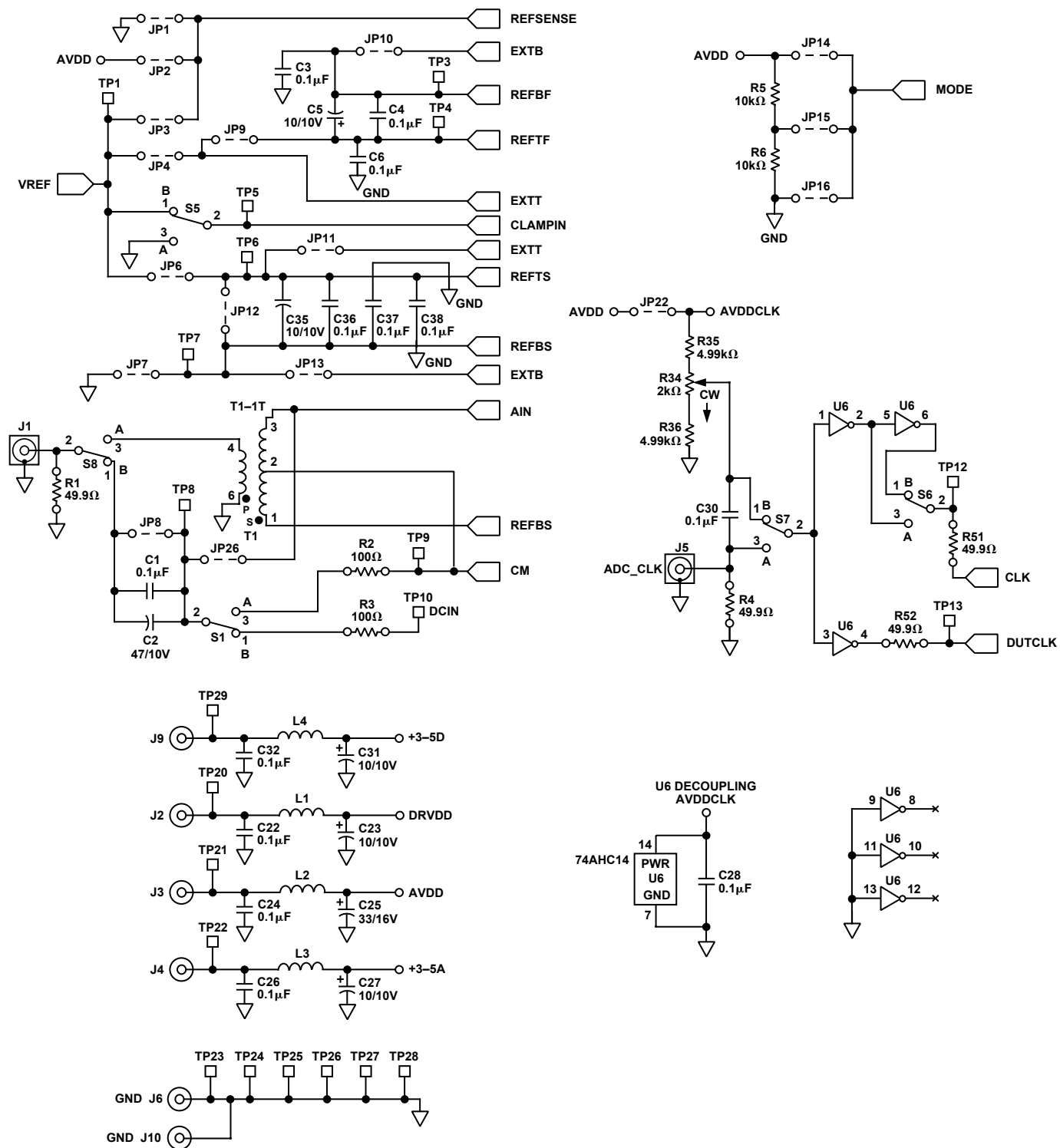

Figure 39b. Evaluation Board Schematic

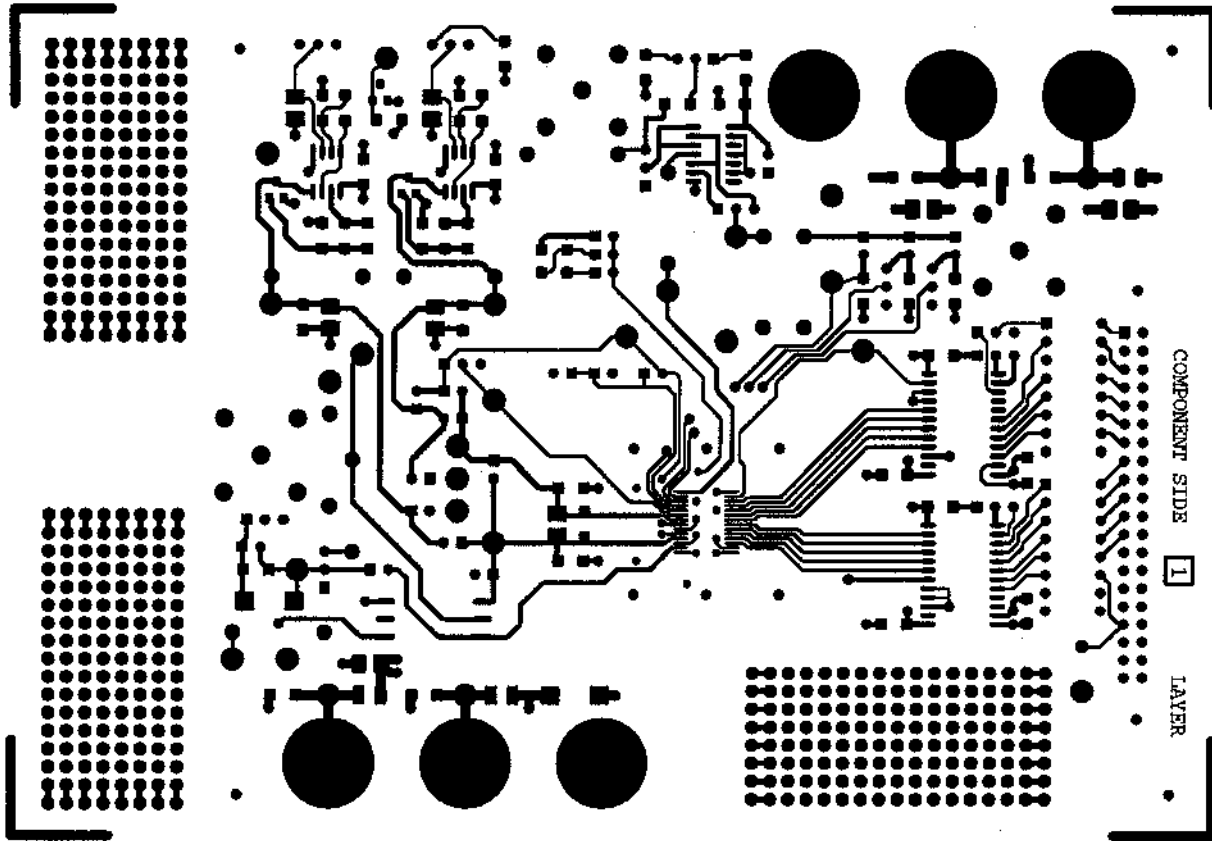

Figure 40a. Evaluation Board, Component Signal (Not to Scale)

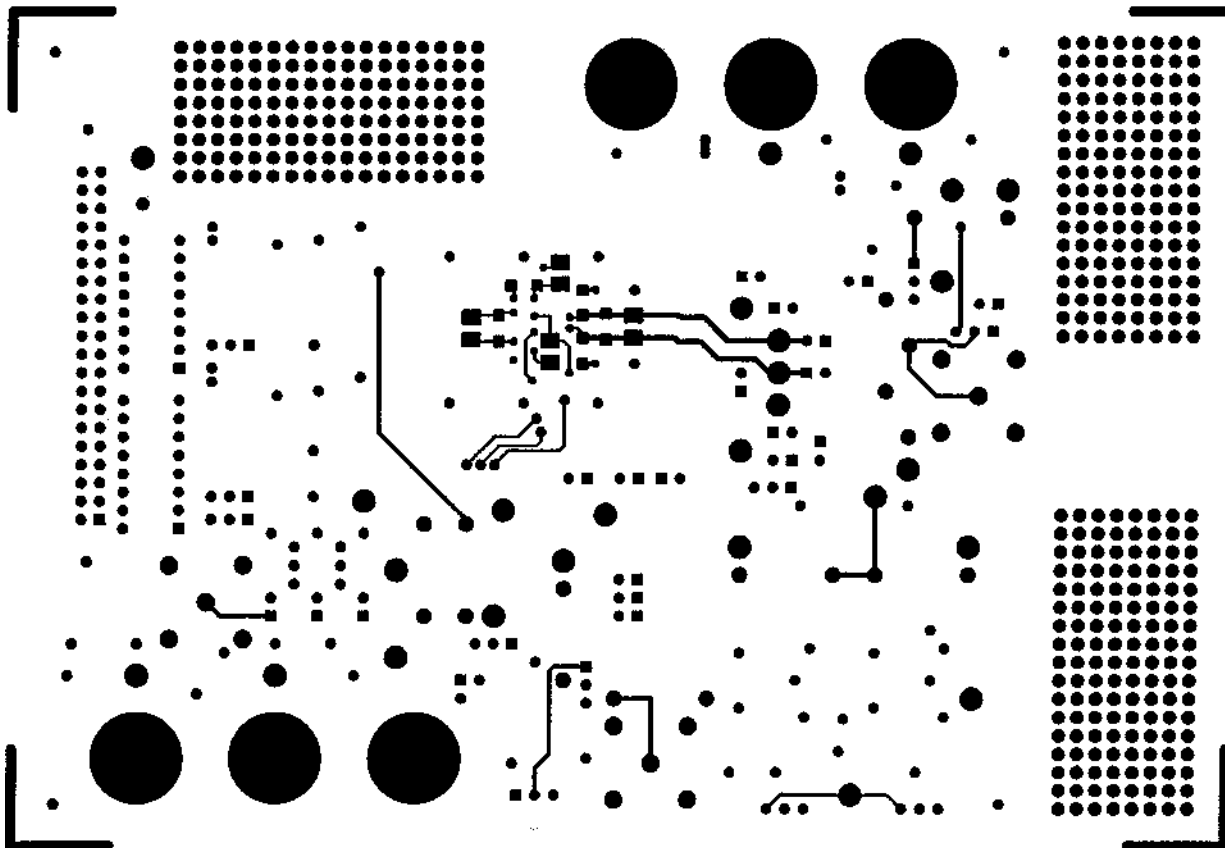

Figure 40b. Evaluation Board, Solder Signal (Not to Scale)

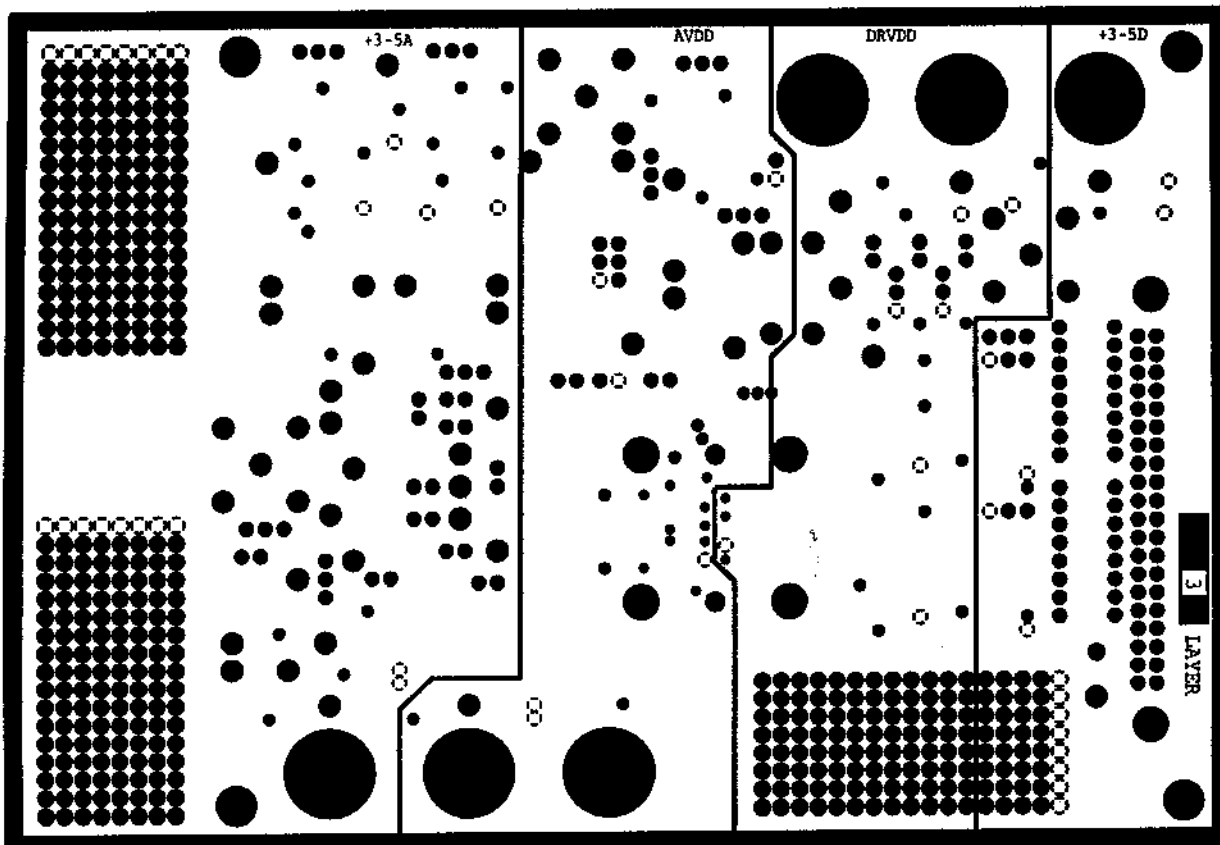

Figure 40c. Evaluation Board Power Plane (Not to Scale)

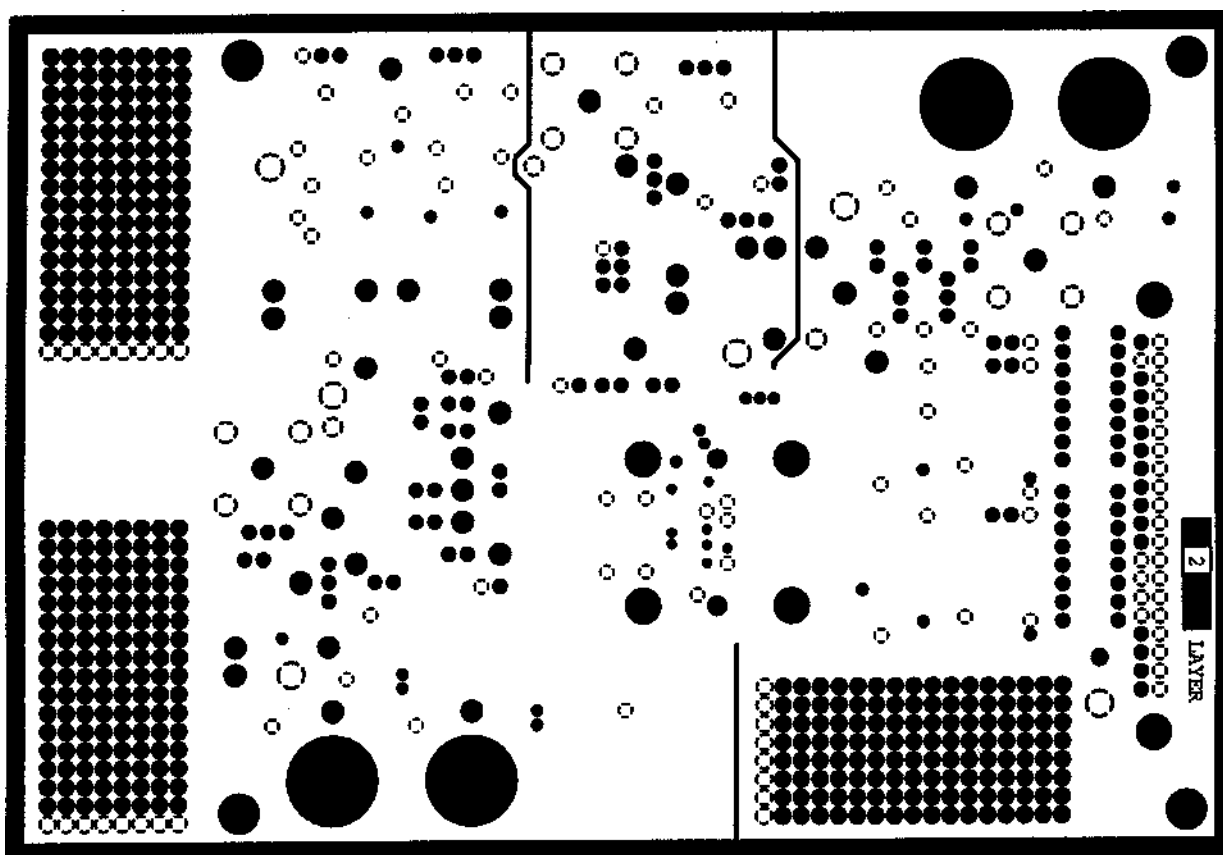

Figure 40d. Evaluation Board Ground Plane (Not to Scale)

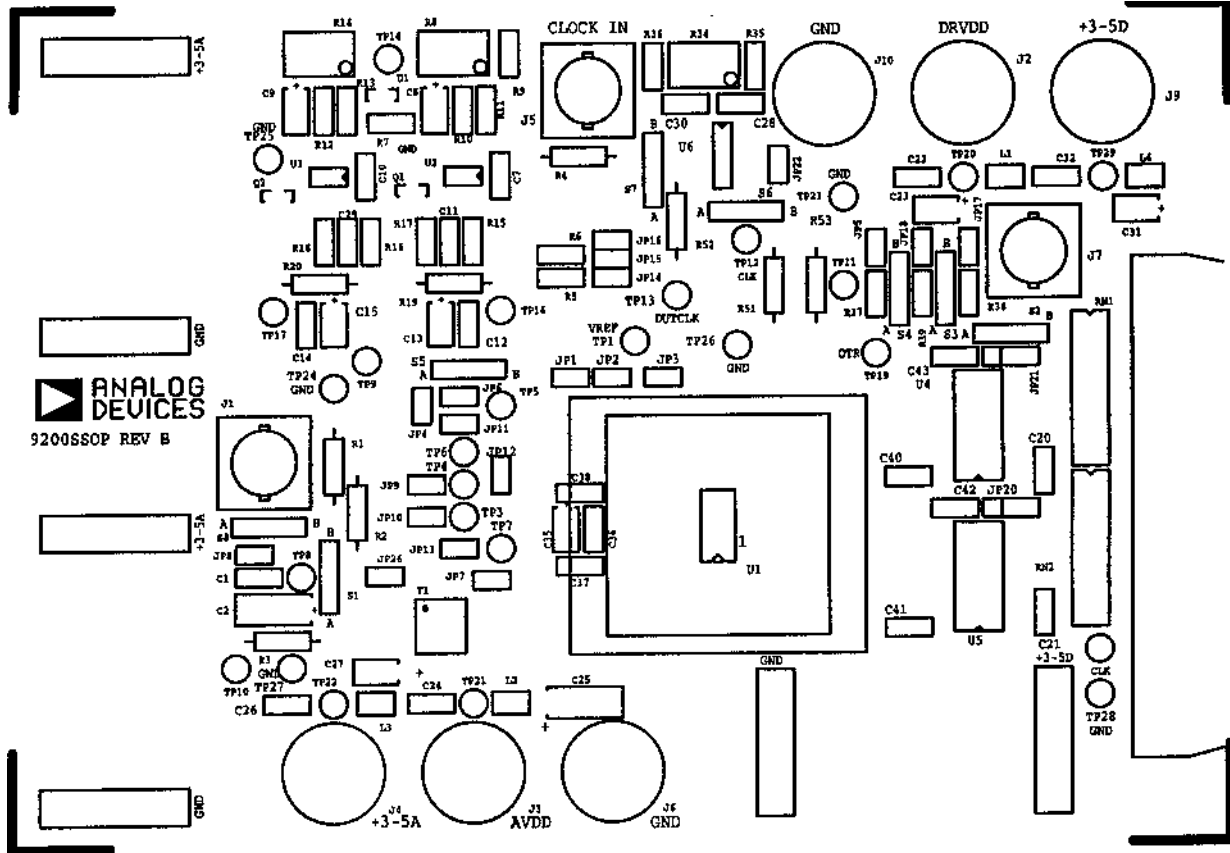

Figure 40e. Evaluation Board Component Silk (Not to Scale)

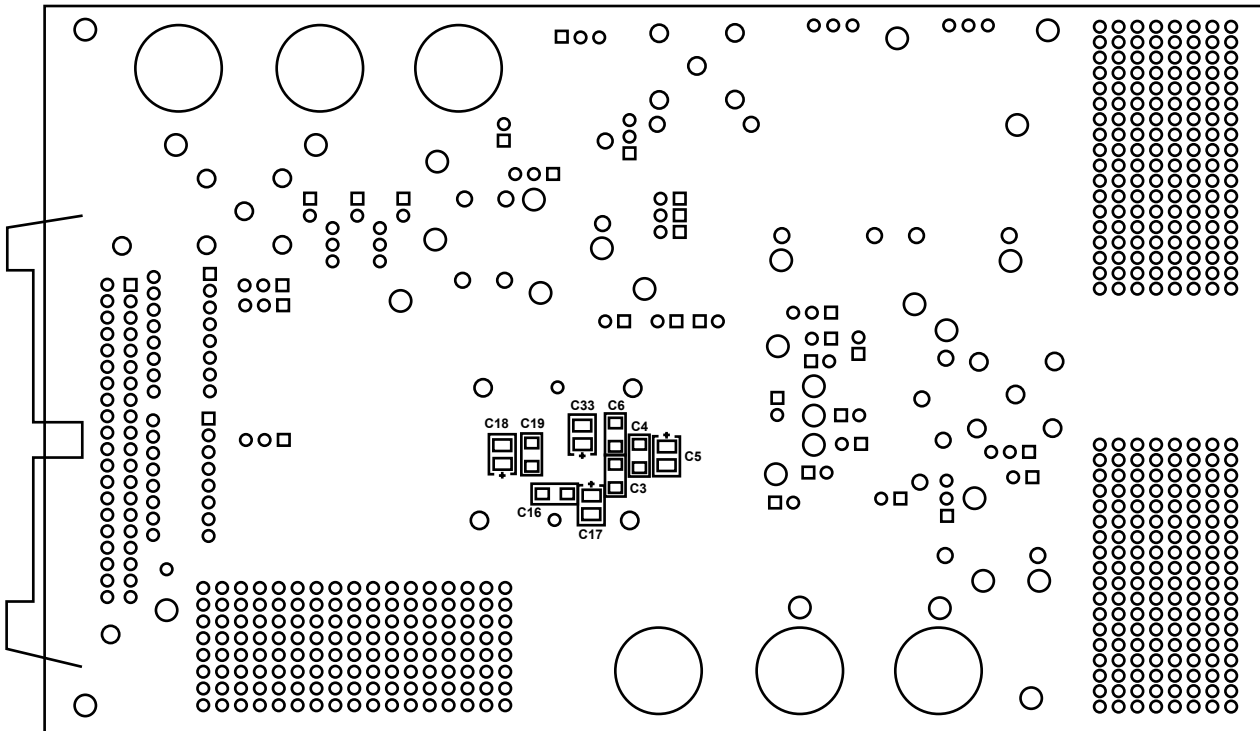

Figure 40f. Evaluation Board Solder Silk (Not to Scale)

GROUNDING AND LAYOUT RULES

As is the case for any high performance device, proper grounding and layout techniques are essential in achieving optimal performance. The analog and digital grounds on the AD9280 have been separated to optimize the management of return currents in a system. Grounds should be connected near the ADC. It is recommended that a printed circuit board (PCB) of at least four layers, employing a ground plane and power planes, be used with the AD9280. The use of ground and power planes offers distinct advantages:

1. The minimization of the loop area encompassed by a signal and its return path.
2. The minimization of the impedance associated with ground and power paths.
3. The inherent distributed capacitor formed by the power plane, PCB insulation and ground plane.

These characteristics result in both a reduction of electromagnetic interference (EMI) and an overall improvement in performance.

It is important to design a layout that prevents noise from coupling onto the input signal. Digital signals should not be run in parallel with the input signal traces and should be routed away from the input circuitry. Separate analog and digital grounds should be joined together directly under the AD9280 in a solid ground plane. The power and ground return currents must be carefully managed. A general rule of thumb for mixed signal layouts dictates that the return currents from digital circuitry should not pass through critical analog circuitry.

DIGITAL OUTPUTS

Each of the on-chip buffers for the AD9280 output bits (D0–D7) is powered from the DRVDD supply pins, separate from AVDD. The output drivers are sized to handle a variety of logic families while minimizing the amount of glitch energy generated. In all cases, a fan-out of one is recommended to keep the capacitive load on the output data bits below the specified 20 pF level.

For $DRVDD = 5\text{ V}$, the AD9280 output signal swing is compatible with both high speed CMOS and TTL logic families. For TTL, the AD9280 on-chip, output drivers were designed to support several of the high speed TTL families (F, AS, S). For applications where the clock rate is below 32 MSPS, other TTL families may be appropriate. For interfacing with lower voltage CMOS logic, the AD9280 sustains 32 MSPS operation with $DRVDD = 3\text{ V}$. In all cases, check your logic family data sheets for compatibility with the AD9280 Digital Specification table.

THREE-STATE OUTPUTS

The digital outputs of the AD9280 can be placed in a high impedance state by setting the THREE-STATE pin to HIGH. This feature is provided to facilitate in-circuit testing or evaluation.

OUTLINE DIMENSIONS

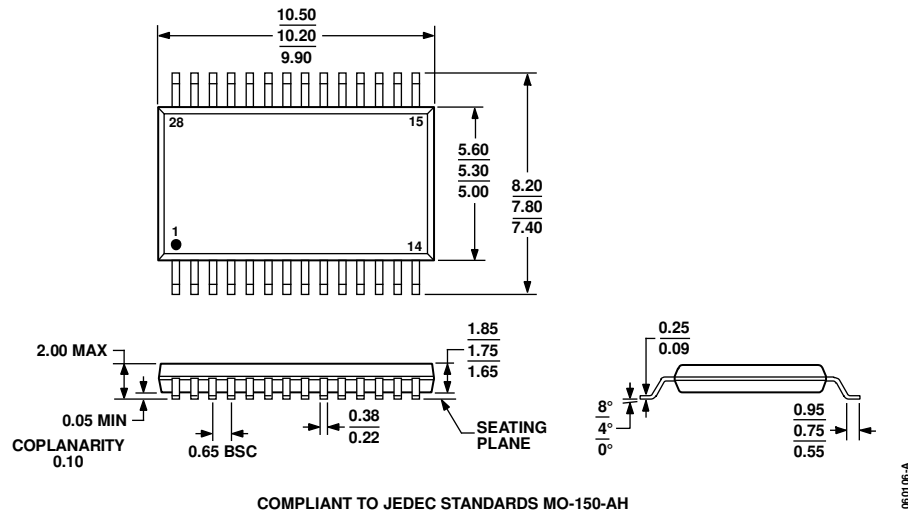

ORDERING GUIDE

Model ¹	Temperature Range	Package Description	Package Option ²
AD9280ARS	-40°C to +85°C	28-Lead SSOP	RS-28
AD9280ARSRL	-40°C to +85°C	28-Lead SSOP	RS-28
AD9280ARSZ	-40°C to +85°C	28-Lead SSOP	RS-28
AD9280ARSZRL	-40°C to +85°C	28-Lead SSOP	RS-28
AD9280-EB		Evaluation Board	

¹ Z = RoHS Compliant Part.

² RS = Shrink Small Outline.

REVISION HISTORY

8/10—Rev. D to Rev. E

Changes to Pin Configuration and Pin Function Descriptions..	5
Updated Outline Dimensions.....	24
Changes to Ordering Guide.....	24