

THIS DRAWING IS UNPUBLISHED. RELEASED FOR PUBLICATION
 © COPYRIGHT 2005 By - ALL RIGHTS RESERVED.

LOC		DIST		REVISIONS			
P	LTR	DESCRIPTION		DATE	DWN	APVD	
GP	00	B	REVISED PER ECO-14-011808	11AUG2014	AP	SB	

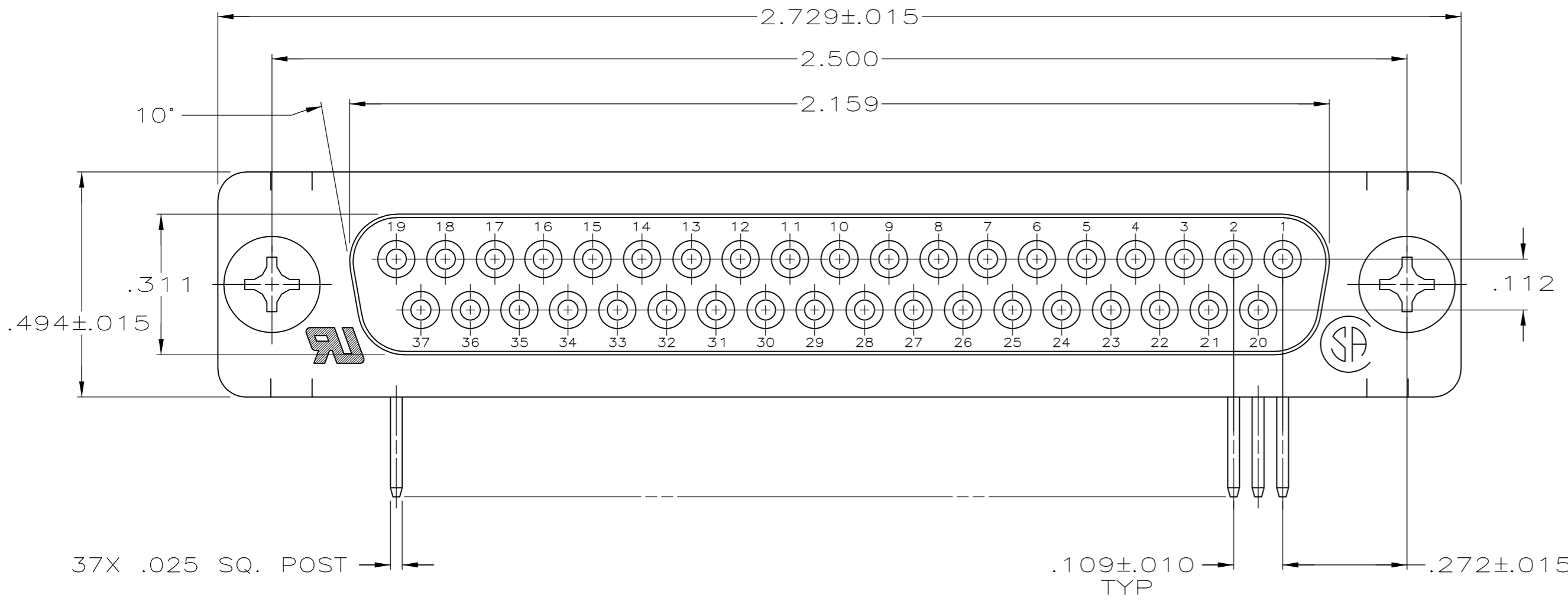

- ⚠ MOLDDED PARTS: GLASS-FILLED PBT OR GLASS-FILLED NYLON, UL94V-0 RATED. COLOR: BLACK.
SHELLS & BRACKETS: CARBON STEEL.
CONTACTS: PHOSPHOR BRONZE.
- ⚠ SHELLS: .000200 MIN TIN OVER .000100 MIN COPPER.
BRACKETS: .000200 MIN TIN OVER .000050 MIN COPPER.
CONTACTS: .000030 MIN GOLD FOR A LENGTH OF .100 MIN FROM MATING END, .000100 MIN TIN ON OPPOSITE END, BOTH OVER .000050 MIN NICKEL.
-OR-
GOLD FLASH OVER .000030 MIN PALLADIUM NICKEL PLATED FOR A LENGTH OF .100 MIN FROM MATING END, .000100 MIN TIN ON OPPOSITE END, BOTH OVER .000050 MIN NICKEL.

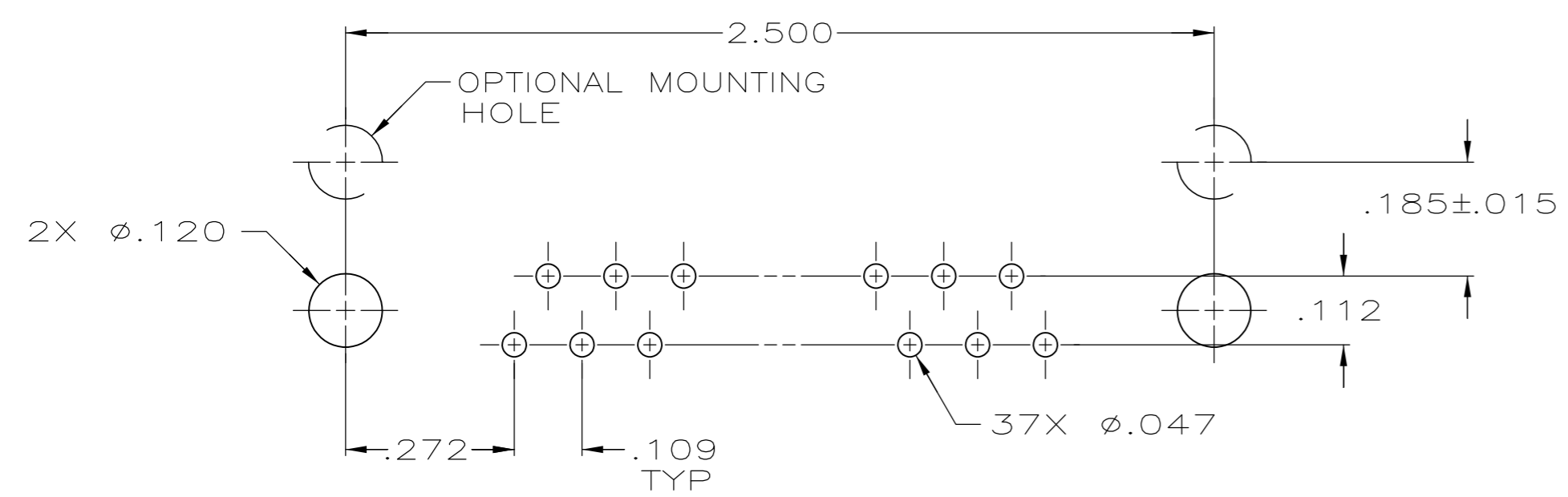
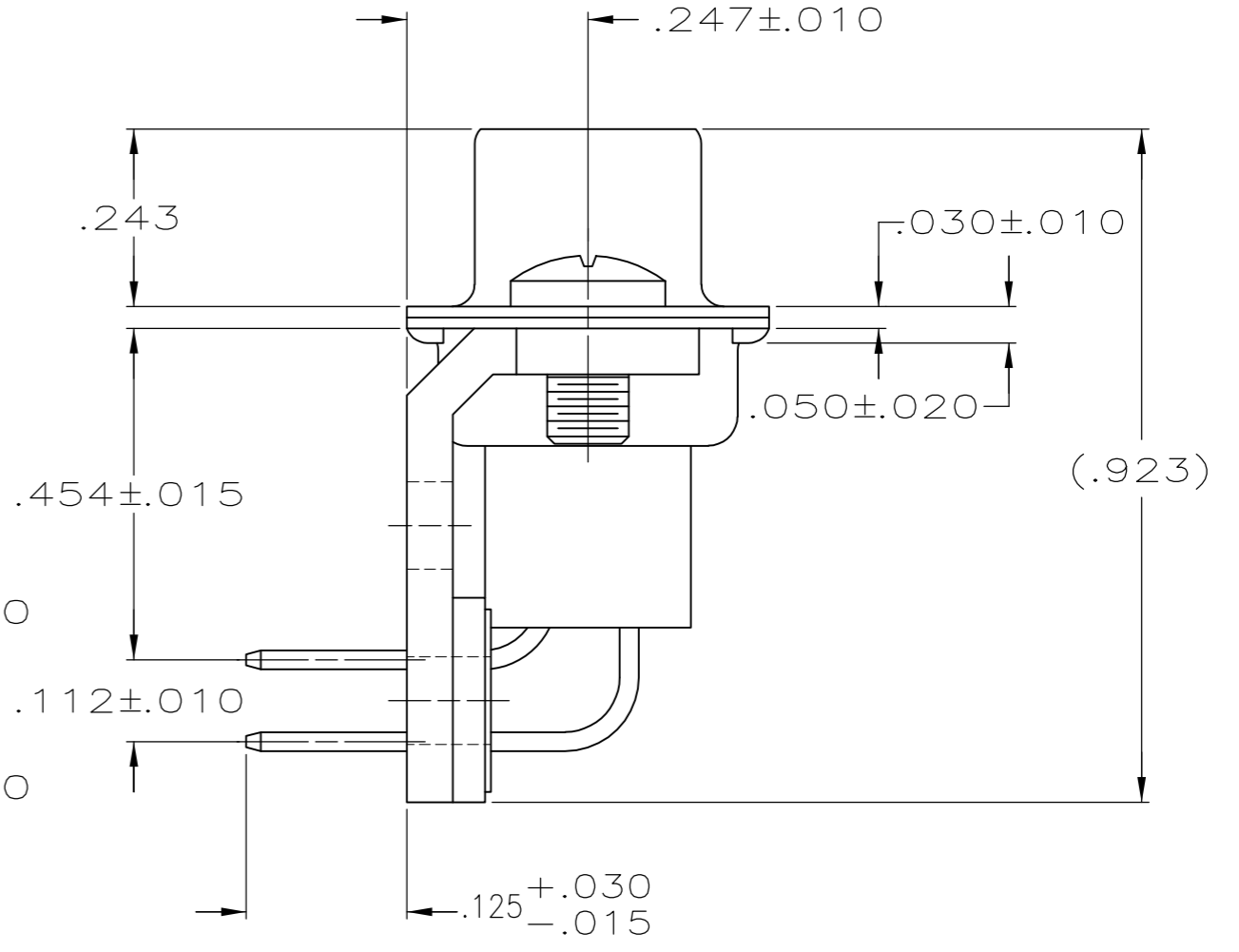
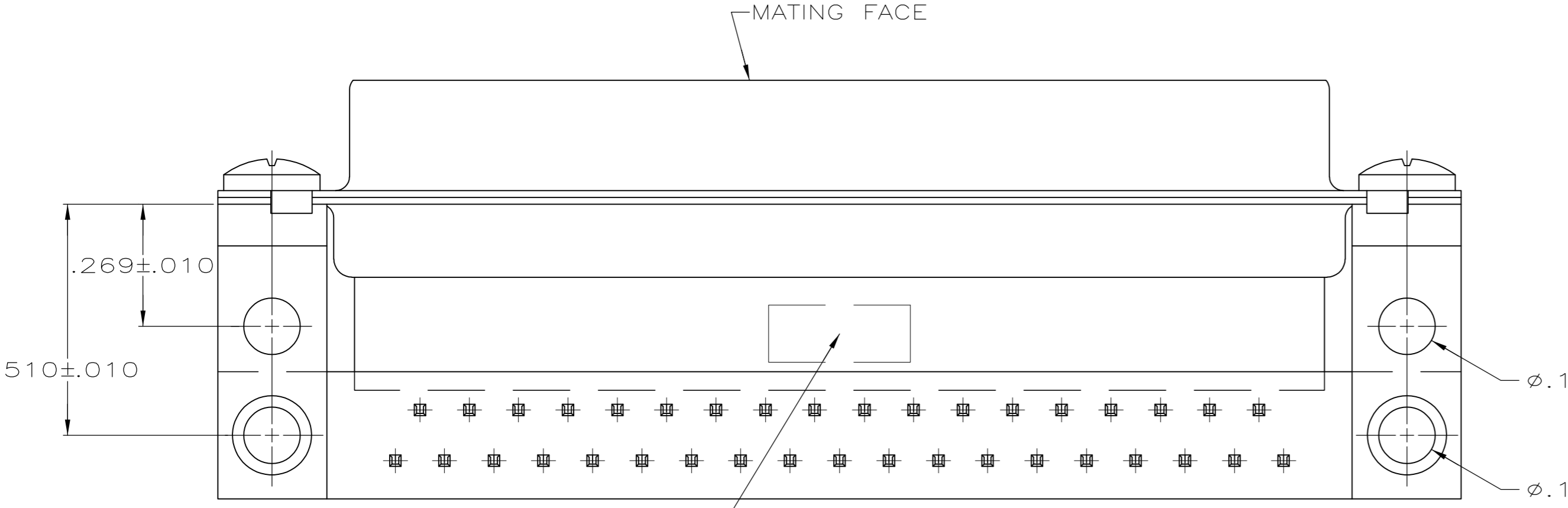

P.C. BOARD MOUNTING DIMENSIONS

5745441

5745441-4
PART NUMBER

THIS DRAWING IS A CONTROLLED DOCUMENT.		DWN D. HENNY 8-31-05	TE Connectivity	
DIMENSIONS: INCHES		CHK S. BOLASH 8-31-05		
TOLERANCES UNLESS OTHERWISE SPECIFIED:		APVD M. WALMSLEY 8-31-05	NAME RECEPTACLE ASSEMBLY, SIZE 4, 37 POSITION, RIGHT ANGLE, .454 SERIES, .025 SQ. POSTS, AMPLIMITE HDP	
0 PLC ± -		PRODUCT SPEC 108-40025	SIZE A2	CAGE CODE 00779
1 PLC ± -		APPLICATION SPEC 114-40013	DRAWING NO C=5745441	RESTRICTED TO -
2 PLC ± -		WEIGHT -	SCALE 4:1	SHEET 1 of 1
3 PLC ± .005		CUSTOMER DRAWING	REV B	
4 PLC ± -				
ANGLES ± 2°				
FINISH				