

**Built-in 32.768 kHz-DTCXO, High Stability
I²C-Bus INTERFACE REAL TIME CLOCK MODULE**

RX - 8801 SA / JE

- Built in frequency adjusted 32.768 kHz crystal unit and DTCXO.
- Interface Type : I²C-Bus Interface (400 kHz)
- Interface voltage range : 1.6 V to 5.5 V
- Temp.compensated voltage range: 2.2 V to 5.5 V
- Wide Timekeeper voltage range : 1.6 V to 5.5 V
- 32.768 kHz frequency output function : C-MOS output With Control Pin
- The various functions include full calendar, alarm, timer.

* The I²C-Bus is a trademark of NXP Semiconductors



Product Number (Please contact us)
RX-8801SA : X1B000011xxxx00
RX-8801JE : X1B000031xxxx00

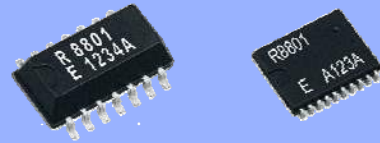

Actual size



Block diagram

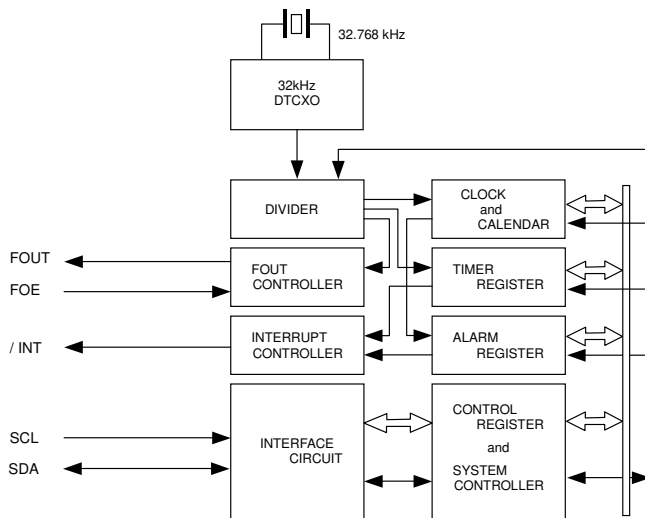

Overview

- High Stability
 - UA
 - ± 1.9 × 10⁻⁶ / 0 °C to +40 °C
(Equivalent to 5 seconds of month deviation)
 - ± 3.4 × 10⁻⁶ / -40 °C to +85 °C
(Equivalent to 9 seconds of month deviation)
 - UB
 - ± 3.8 × 10⁻⁶ / 0 °C to +50 °C
(Equivalent to 10 seconds of month deviation)
 - ± 5.0 × 10⁻⁶ / -40 °C to +85 °C
(Equivalent to 13 seconds of month deviation)
- 32.768 kHz frequency output function
 - FOUT pin output (C-MOS output), CL=30 pF
 - Output selectable
< 32.768 kHz, 1024 Hz, 1 Hz >
- The various interrupt
 - Timer Function can be set up between 1/4096 second and 255 minutes.
 - Alarm Function can be set to day of week, day, hour, or minute.

*It is possible to use it by the terminal connection as 32.768 kHz-DTCXO.

Pin Function

Signal Name	I / O	Function
T1(CE)	input	* Use by the manufacture for testing. (Do not connect externally.)
SCL	input	Serial clock input pin
FOUT	Output	The pin outputs the reference clock signal. (CMOS output)
TEST	input	* Use by the manufacture for testing. (Do not connect externally.)
VDD	-	Connected to a positive power supply
FOE	input	The input pin for the FOUT output control.
/INT	Output	Interrupt output (N-ch open drain)
GND	-	Connected to a ground
T2(VPP)	-	* Use by the manufacture for testing. (Do not connect externally.)
SDA	I / O	Data input and output pin

Terminal connection / External dimensions

(Unit:mm)

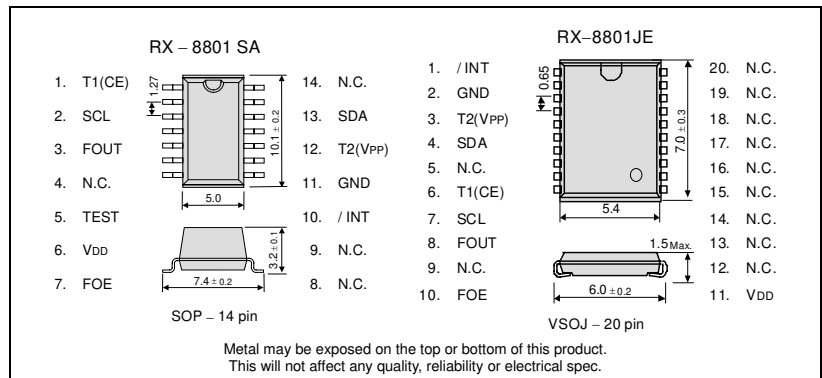

Specifications (characteristics)

* Refer to application manual for details.

■ Electrical Characteristics

Item	Symbol	Condition	Min.	Typ.	Max.	Unit	
Interface voltage	V _{DD}	Interface voltage	1.6	3.0	5.5	V	
Temp. compensated Voltage	V _{TEM}	Temp. compensated voltage	2.2	3.0	5.5	V	
Clock voltage	V _{CLK}	-	1.6	3.0	5.5	V	
Operating temperature	T _{OPR}	-	-40	+25	+85	°C	
Stability	Δf/f	UA	Ta = 0 °C to +40 °C	±1.9 ^{*1}		× 10 ⁻⁶	
			Ta = -40 °C to +85 °C	±3.4 ^{*2}			
		UB	Ta = 0 °C to +50 °C	±3.8 ^{*3}			
			Ta = -40 °C to +85 °C	±5.0 ^{*4}			
Current consumption (1)	I _{BK1}	Backup Mode FOE = GND, /INT = V _{DD} FOUT output : OFF	V _{DD} = 5V	-	1.2	3.4	μA
Current consumption (2)	I _{BK2}		V _{DD} = 3V	-	0.8	2.1	μA

*1) Equivalent to 5 seconds of month deviation. *2) Equivalent to 9 seconds of month deviation.
 *3) Equivalent to 10 seconds of month deviation. *4) Equivalent to 13 seconds of month deviation.

■ 32.768 kHz-DTCXO Frequency temperature characteristics (Example)

