

| PART NO. | LENGTH |
|-----------|--------|
| 849140303 | 2M |
| 849140304 | 5M |
| 849140305 | 10M |
| 849140323 | 4M |
| 849140324 | 8M |

| REV | DATE | ECN NO. | APPVD BY | REL BY |
|-----|---------|------------------------|----------|--------|
| A | 2-25-00 | UM2000-0454 PROD. REL. | FVW | |
| B | 8-24-00 | UM2001-0054 | | |

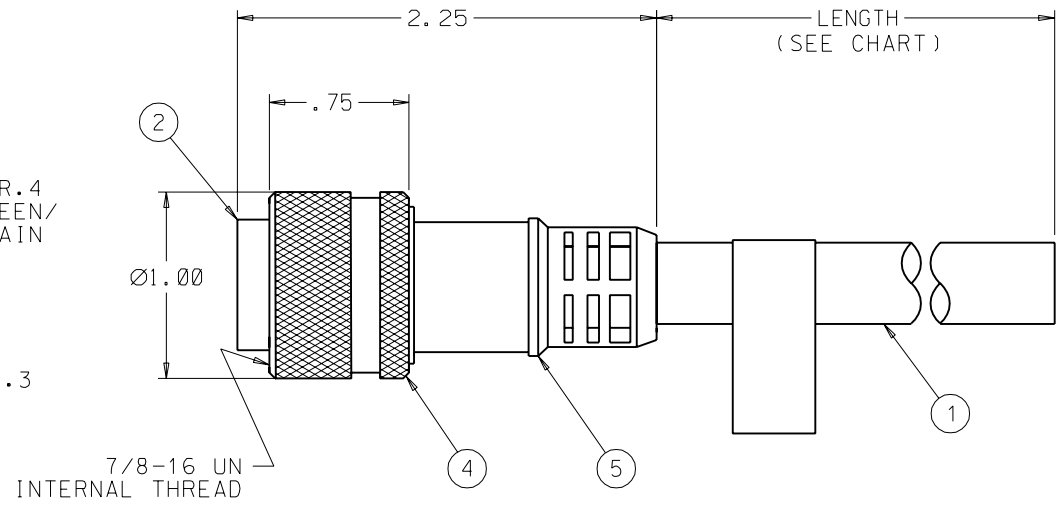
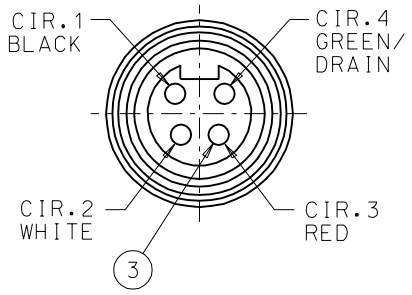

P1

| | |
|---|-------|
| 1 | BLK |
| 2 | WHT |
| 3 | RED |
| 4 | GRN |
| | DRAIN |

WIRING DIAGRAM

| 5 | 1 | MOLDED BODY | PVC/COLOR:GRAY |
|------|-----------|--------------------------|-------------------------|
| 4 | 1 | COUPLING RING, INT. THD. | STAINLESS STEEL |
| 3 | 4 | CONTACT, PIN | COPPER ALLOY/TIN PLATED |
| 2 | 1 | INSERT, PIN | PVC/COLOR:GRAY |
| 1 | SEE CHART | CABLE, 4/C, 16 AWG. | PUR JACKET/COLOR: GRAY |
| ITEM | QTY | DESCRIPTION | MATERIAL/FINISH |

| | | | |
|----------------------------------------------------------|----------------------------------------------------------------------------------------------------------------------------------------|------------------------------------------------------------------------------------------------------|--------------------------------------------------------------|
| QUALITY SYMBOLS MAJOR = CRITICAL = SPC = | UNLESS SPECIFIED: ALL DIMENSIONS IN INCHES GENERAL TOLERANCES: 3 PLACE ±.005 2 PLACE ±.01 ANGULAR ±2° | SCALE --- DWG SIZE B THIRD ANGLE PROJECTION | REVISE ON CAD ONLY |
| | Uti-Mate CAGE CODE 58967 | DRAWN BY & DATE GF 2-25-00 CHECKED BY & DATE SU 2-25-00 APPROVED BY & DATE DW 2-25-00 | TITLE: MINI-C, PLUG, MALE, 4 POLE, 16 AWG, PUR, NEC |
| | | PART NO. SEE CHART DRAWING NO. SD-84914-0303 | SHEET NO. 1 OF 1 REV B |
| | THIS DRAWING CONTAINS INFORMATION THAT IS PROPRIETARY TO MOLEX INCORPORATED AND SHOULD NOT BE USED WITHOUT WRITTEN PERMISSION. | | |