

ZL6100EVAL1Z

Evaluation Board

AN1493
Rev 0.00
September 4, 2009

The ZL6100 is an integrated mixed-signal power conversion and management IC that combines an efficient step-down DC/DC converter with key power and thermal management functions in a single package. The ZL6100 incorporates current sharing and adaptive efficiency-optimization algorithms to provide a flexible, efficient power IC building block.

The ZL6100EVAL1Z platform is a 4-layer board demonstrating a 15A synchronous buck converter. Sequencing, tracking, margining, plus other features can be evaluated using this board.

A USB to SMBus adapter board can be used to connect the evaluation board to a PC. The PMBus command set is accessed by using the Zilker Labs PowerNavigator™ evaluation software from a PC running Microsoft Windows.

Key Features

- 15A Synchronous Buck Converter
- Optimized for Small Circuit Footprint and Dynamic Response
- Configurable through SMBus
- Onboard Enable Switch
- Power-Good Indicator

Ordering Information

PART NUMBER	DESCRIPTION
ZL6100EVAL1Z	ZL6100 Evaluation Kit (EVB, USB Adapter, Cable, Software)

Target Specifications

- $V_{IN} = 12V$
- $V_{OUT} = 1.2V/15A$ (20A max)
- $f_{sw} = 400kHz$
- Efficiency: 86% at 10A
- Output Ripple: $\pm 1\%$
- Dynamic Response: $\pm 3\%$
(50% to 100% to 50% load step, $di/dt = 2.5A/\mu s$)
- Board Temperature: $+25^{\circ}C$

Functional Description

The ZL6100EVAL1Z provides all circuitry required to demonstrate the features of the ZL6100. The ZL6100EVAL1Z has a functionally-optimized ZL6100 circuit layout that allows efficient operation up to the maximum output current. Power and load connections are provided through plug-in sockets.

A majority of the features of the ZL6100 such as soft-start delay and ramp times, supply sequencing, voltage tracking, and voltage margining are available on this evaluation board. For voltage tracking and sequencing evaluation, the board can be connected to any other Zilker Labs evaluation board that supports the Digital DC (DDC) bus.

Figure 1 shows a functional block diagram of the ZL6100EVAL1Z board. The SMBus address is selectable through a jumper on the top side of the board. All power to the board (V_{IN} and I^2C bus) must be removed before changing the jumpers.

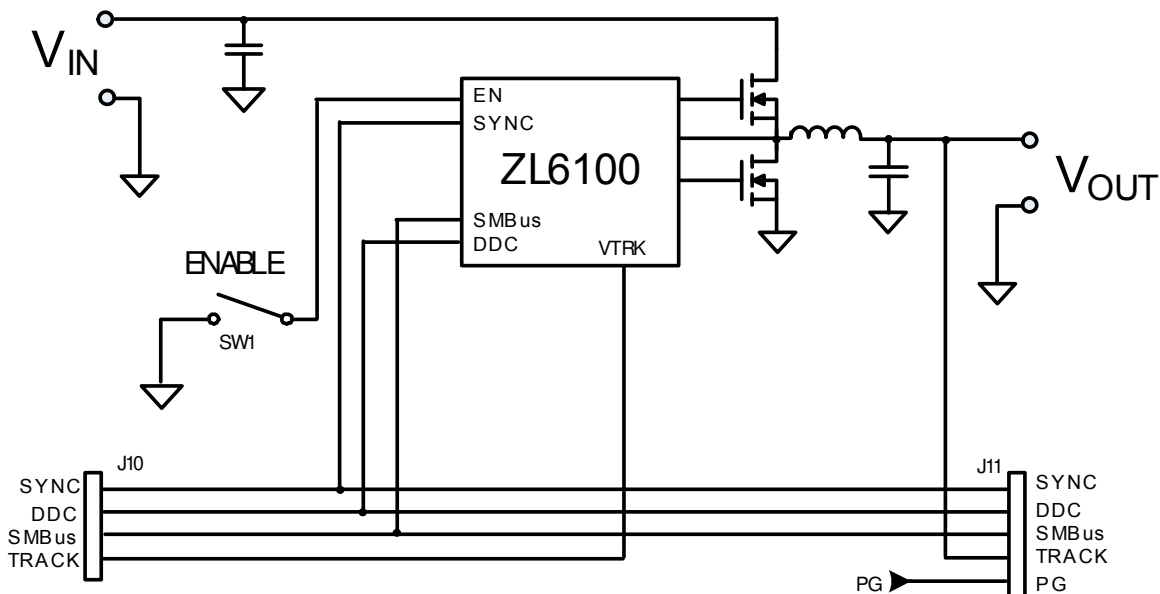

FIGURE 1. ZL6100EVAL1Z BLOCK DIAGRAM

The hardware enable function is controlled by a toggle switch on the ZL6100EVAL1Z board. The power-good (PG) LEDs indicate the correct state of PG when external power is applied to the ZL6100EVAL1Z board. The right angle headers at opposite ends of the board are for connecting a USB to SMBus adapter board or for daisy chaining of multiple evaluation boards.

Figure 2 shows the operational circuit. The circuit consists of the ZL6100 IC with its minimal component count to realize a 15A buck converter. The board layout has been optimized for thermal performance. Figure 3 is the board interface circuitry and Figures 4 through 8 demonstrate the PCB Board Layout, which includes the board fabrication notes.

The Bill of Materials (BOM) and configuration file are also included for reference beginning on page 10.

Operation

PMBus Operation

The ZL6100 utilizes the PMBus protocol. The PMBus functionality can be controlled via USB from a PC running the PowerNavigator evaluation software in a Windows XP or Windows 2000/NT operating system.

Install the evaluation software using the CD included in the ZL6100EVAL1Z kit.

For board operation, connect the included USB-to-SMBus adapter board to J10 of the ZL6100EVAL1Z board. Connect the desired load and an appropriate power supply to the input and connect the included USB cable to the PC running the PowerNavigator evaluation software. Place the ENABLE switch in "DISABLE" and turn on the power.

The evaluation software allows modification of all ZL6100 PMBus parameters. The ZL6100 device on the board has been pre-configured as described in this document, but the user may modify the operating parameters through the evaluation software or by loading a predefined scenario from a configuration file.

Use the mouse-over pop-ups for PowerNavigator help. Refer to Zilker Labs application note AN2033 for PMBus details.

The ENABLE switch can then be moved to "ENABLE" and the ZL6100EVAL1Z board can be tested. Alternately, the PMBus ON-OFF CONFIG and OPERATION commands may be used.

Quick Start Guide

Stand Alone Operation

1. Set ENABLE switch to "DISABLE"
2. Apply load to V_{OUT+}/V_{OUT-}
3. Connect the USB to SMBus adapter board to J10 of ZL6100EVAL1Z (Optional: provides power for onboard LED's so that LED power does not detract from efficiency measurement)
4. Connect supplied USB cable from computer to USB to SMBus adapter board (Optional: provides power for onboard LED's so that LED power does not detract from efficiency measurement)
5. Connect power supply to V_{IN+}/V_{IN-} (supply turned off)
6. Turn power supply on
7. Set ENABLE switch to "ENABLE"
8. Monitor ZL6100EVAL1Z board operation using an oscilloscope

USB (PMBus) Operation

1. Set ENABLE switch to "DISABLE"
2. Apply load to V_{OUT+}/V_{OUT-}
3. Connect power supply to V_{IN+}/V_{IN-} (supply turned off)
4. Turn power supply on
5. Insert the Zilker Labs Eval Kit CD
6. Connect USB to SMBus adapter board to J10 of ZL6100EVAL1Z
7. Connect supplied USB cable from computer to USB to SMBus adapter board.
 - Upon first-time connection, the Found New Hardware Wizard will appear.
 - Windows XP users: Select 'No' at prompt to search the Internet for drivers.
 - Follow the steps on the screen to install the drivers from the CD.
8. Install the PowerNavigator evaluation software by running setup.exe from the PowerNavigator_installer folder on the CD.
9. Set ENABLE switch on EVB to "ENABLE"
10. Monitor and configure the ZL6100EVAL1Z board using PMBus commands in the evaluation software
11. Test the ZL6100EVAL1Z operation using an oscilloscope and the evaluation software.

ZL6100EVAL1Z BOARD SCHEMATICS

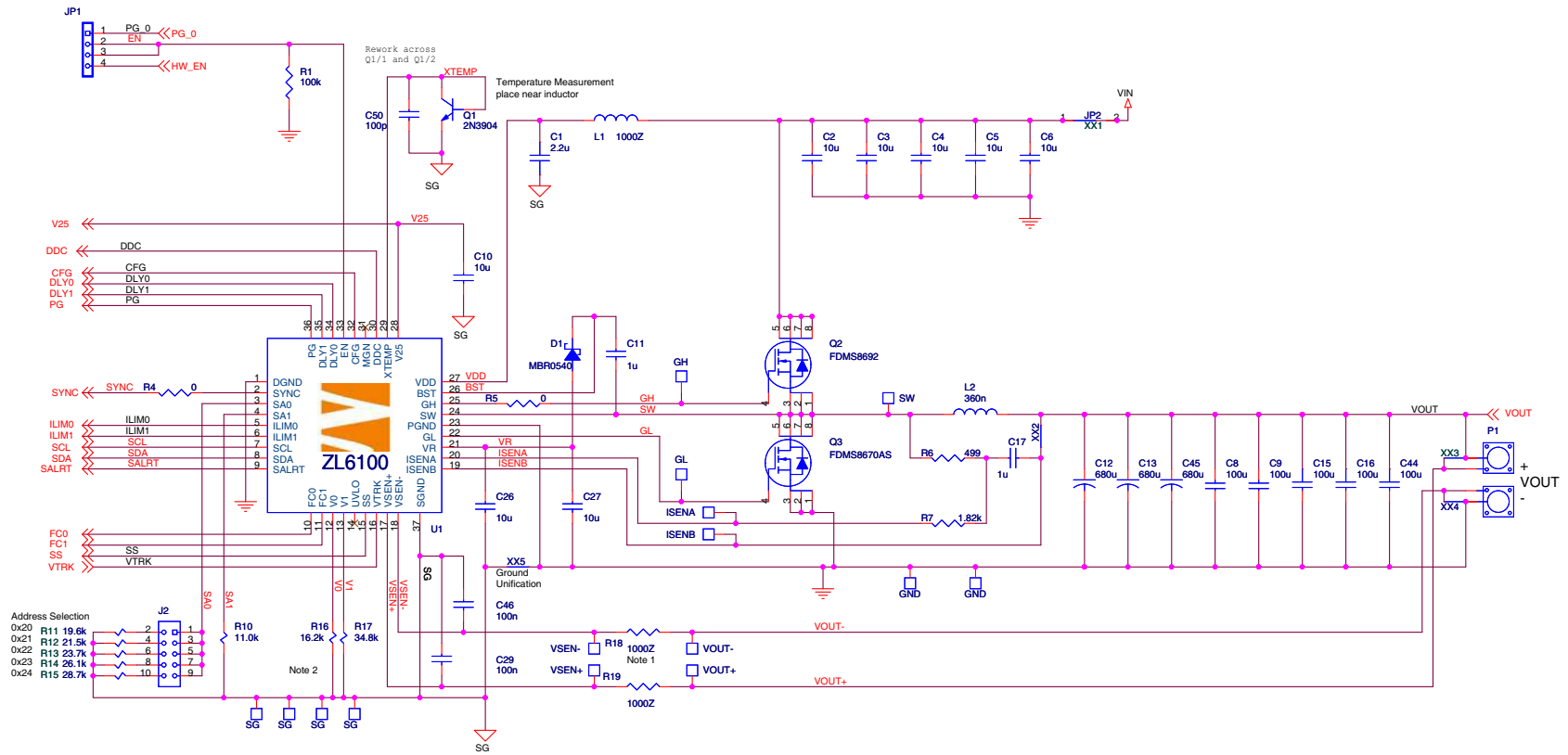

- Notes:
- 1) Frequency response measurement components. (backside)
Substitute with 49.9 Ohm resistors for loop injection.
 - 2) Vout is pinstrapped to 3.3V. Override with PMBus.
Pinstrap output voltage can be modified to reduce the max output voltage.

NI = Not Installed

The reference designs contained in this document are for reference and example purpose only. THE REFERENCE DESIGNS ARE PROVIDED "AS IS" AND "WITH ALL FAULTS" AND ZILKER LABS DISCLAIMS ALL WARRANTIES, WHETHER DIRECT, INDIRECT, CONSEQUENTIAL (INCLUDING LOSS OF PROFITS), OR OTHERWISE, RESULTING FROM THE REFERENCE DESIGNS OR ANY USE THEREOF. Any use of such reference designs is at your own risk and you agree to indemnify Zilker Labs for any damages resulting from such use.

FIGURE 2. OPERATIONAL CIRCUIT

ZL6100EVAL1Z BOARD SCHEMATICS (Continued)

Board to Board Interface

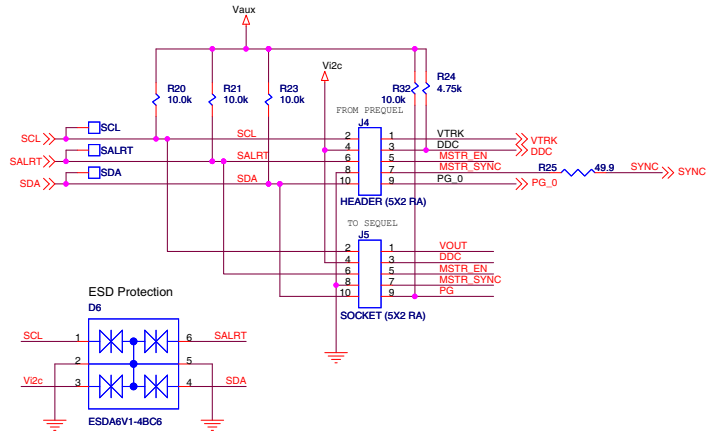

Power In

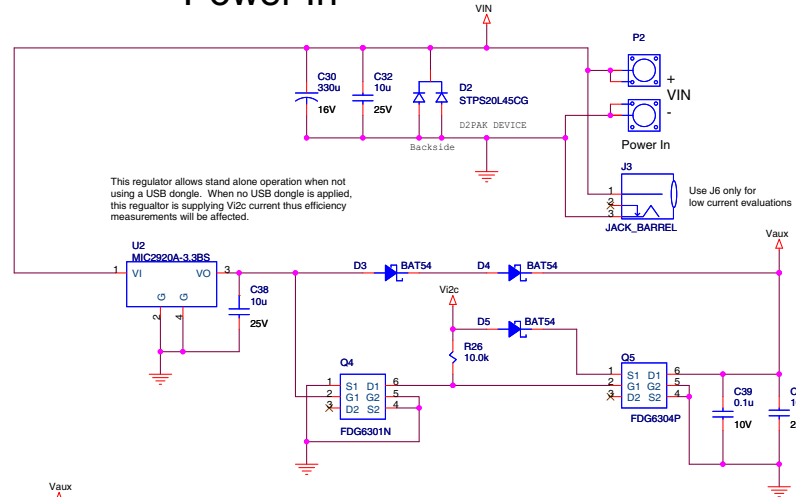

Power Good LED

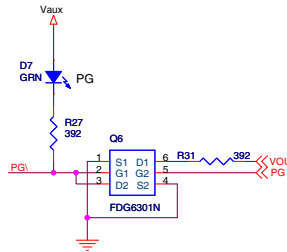

J6 Debounce

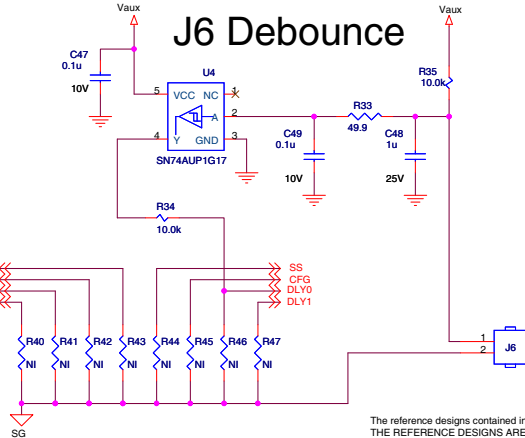

Enable Switch Debounce

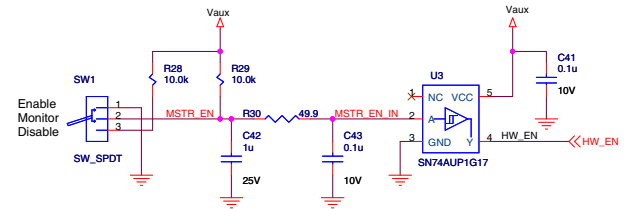

Auxiliary Pinstrap

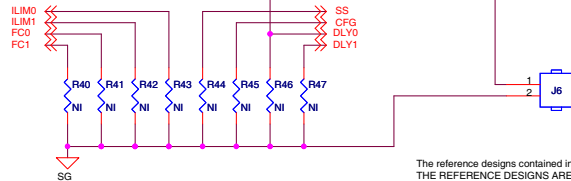

The reference designs contained in this document are for reference and example purpose only. THE REFERENCE DESIGNS ARE PROVIDED 'AS IS' AND 'WITH ALL FAULTS' AND ZILKER LABS DISCLAIMS ALL WARRANTIES, WHETHER DIRECT, INDIRECT, CONSEQUENTIAL (INCLUDING LOSS OF PROFITS), OR OTHERWISE, RESULTING FROM THE REFERENCE DESIGNS OR ANY USE THEREOF. Any use of such reference designs is at your own risk and you agree to indemnify Zilker Labs for any damages resulting from such use.

FIGURE 3. ZL6100EVAL1Z INTERFACE CIRCUITRY

ZL6100EVAL1Z BOARD LAYOUT - 4 LAYERS

FIGURE 4. PCB - TOP LAYER

FIGURE 5. PCB - INNER LAYER 1 (TOP VIEW)

FIGURE 6. PCB - INNER LAYER 2 (TOP VIEW)

ZL6100EVAL1Z BOARD LAYOUT - 4 LAYERS (Continued)

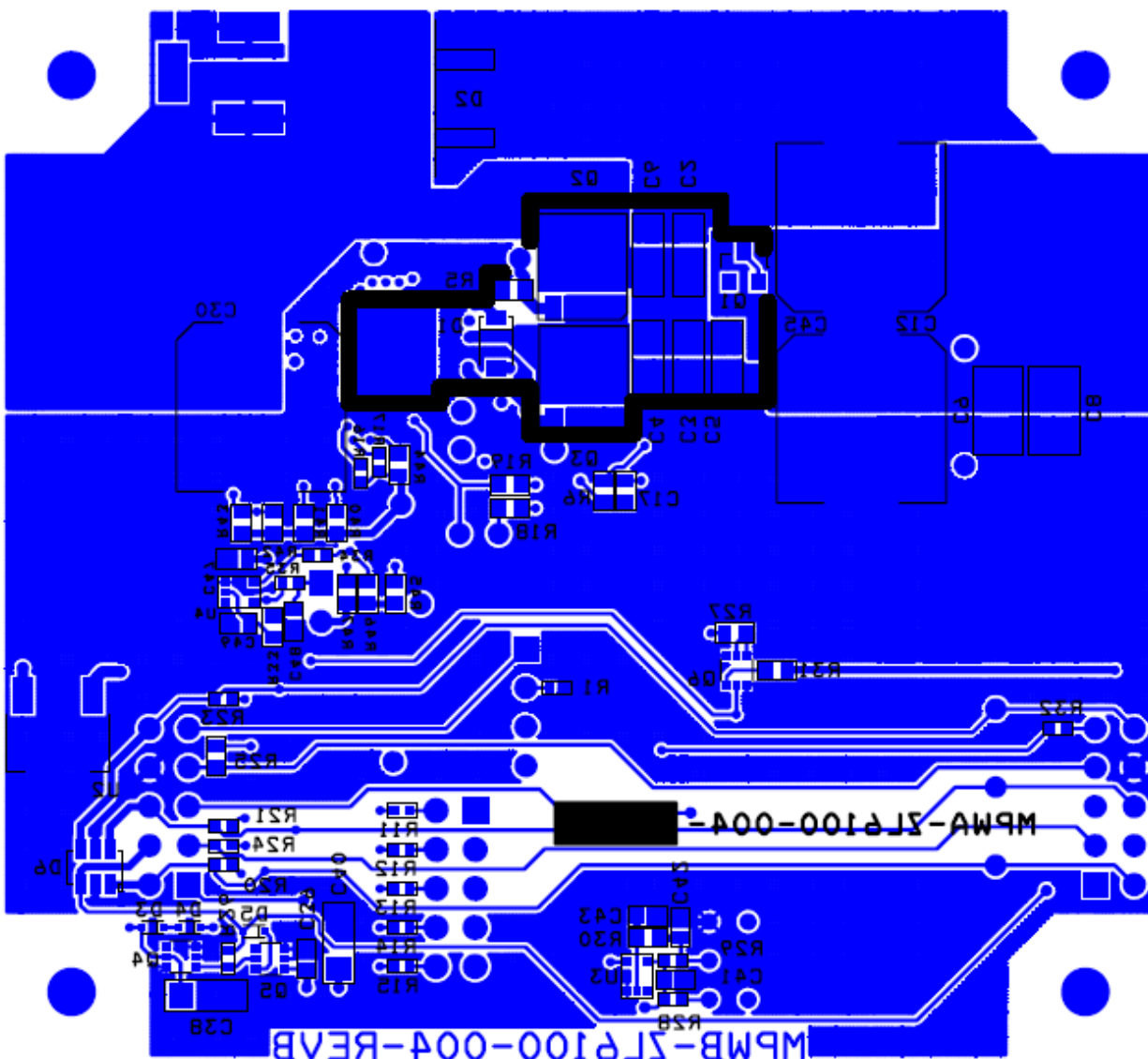

FIGURE 7. PCB - BOTTOM LAYER (TOP VIEW)

ZL6100EVAL1Z BOARD LAYOUT - 4 LAYERS (Continued)

NOTES UNLESS OTHERWISE SPECIFIED:

1. FABRICATE USING ARTWORK AND DRILL FILES PER TABLE BELOW.
2. FINISHED BOARDS MUST CONFORM TO ZILKER LABS QUALITY PROCEDURE SQAS-002-PCBREQ.
3. MATERIAL: NEMA GRADE FR-4; MINIMUM UL FLAMMABILITY RATING 94 V-0
BOARD LAYER SPACING
SPACING BETWEEN 1-2 = .013 TO .017
SPACING BETWEEN 3-4 = .013 TO .017
TOTAL BOARD THICKNESS = .062
4. COPPER THICKNESS SHALL BE 1 OZ. INNER LAYERS, 1 OZ. PLATED TO 2 OZ. OUTER LAYERS.
5. REFERENCE POINT 0,0 FOR DRILL FILE LISTING.
6. ALL HOLES PLATED THROUGH (UNLESS OTHERWISE NOTED). PLATING IN HOLES PER ZILKER LABS QUALITY PROCEDURE SQAS-002-PCBREQ.
7. BOARD COATING SHALL BE SOLDERMASK OVER BARE COPPER, HOT AIR SOLDER LEVELING.
8. SOLDERMASK PER ZILKER LABS QUALITY PROCEDURE SQAS-002-PCBREQ.
9. VENDOR IDENTIFICATION, UL COMPLIANCE AND DATE CODE TO BE PERMANENTLY AFFIXED AND LOCATED AS SHOWN, ON BOTTOM TRACE LAYER.
10. ELECTRICAL TEST MARK, ON BOTTOM TRACE LAYER, PER ZILKER LABS QUALITY PROCEDURE SQAS-002-PCBREQ.
11. FIDUCIALS TOP AND BOTTOM THESE LOCATIONS.
12. WARNING: THE MANUFACTURING PROCESSES AND THE MATERIALS ASSOCIATED WITH THIS PART MAY REQUIRE SPECIAL SAFETY PRECAUTIONS.

FIGURE 8. BOARD FABRICATION NOTES

Bill of Materials

PART NUMBER	QTY	UNIT	REFERENCE DESIGNATOR	DESCRIPTION	MANUFACTURER	MANUFACTURER PART
H1045-00101-100V5-T	1	ea	C50	CAP, SMD, 0603, 100pF, 100V, 5%, NPO, ROHS	PANASONIC	ECJ-1VC2A101J
H1045-00104-10V10-T	3	ea	C39, C41, C43	CAP, SMD, 0603, 0.01µF, 50V, 5%, X7R, ROHS	KEMET	C0603C104K8RACTU
H1045-00104-25V10-T	2	ea	C29, C46	CAP, SMD, 0603, 0.1µF, 25V, 10%, X7R, ROHS	MURATA	GRM39X7R104K025AD
H1045-00105-25V10-T	3	ea	C11, C17, C42	CAP, SMD, 0603, 1µF, 25V, 10%, X5R, ROHS	MURATA	GRM188R61E105KA12D
H1045-00106-6R3V20-T	3	ea	C10, C26, C27	CAP, SMD, 0603, 10µF, 6.3V, 20%, X5R, ROHS	TDK	C1608X5R0J106M
H1045-DNP	0	ea	C47, C48, C49	CAP, SMD, 0603, DNP-PLACE HOLDER, ROHS		
H1046-00225-16V10-T	1	ea	C1	CAP, SMD, 0805, 2.2µF, 16V, 10%, X5R, ROHS	PANASONIC	ECJ-2FB1C225K
H1065-00106-25V10-T	6	ea	C2, C3, C4, C32, C38, C40	CAP, SMD, 1206, 10µF, 25V, 10%, X5R, ROHS	VENKEL	C1206X5R250-106KNE
H1065-DNP	0	ea	C5, C6	CAP, SMD, 1206, DNP-PLACE HOLDER, ROHS		
H1082-00107-6R3V20-T	5	ea	C8, C9, C15, C16, C44	CAP, SMD, 1210, 100µF, 6.3V, 20%, X5R, ROHS	TDK	C3225X5R0J107M
APXA160ARA331MJC0G	1	ea	C30	CAP, SMD, 10x12, 330µF, 16V, 20%, 14mW, ALUM.ELEC., ROHS	NIPPON CHEMI-CON	APXA160ARA331MJC0G
APXA6R3ARA681MJC0G	2	ea	C12, C13	CAP, SMD, 10x12, 680µF, 6.3V, 20%, 10mW, ALUM.ELEC., ROHS	NIPPON CHEMI-CON	APXA6R3ARA681MJC0G
APXA6R3ARA681MJC0G	0	ea	DNP (C45)	CAP, SMD, 10x12, 680µF, 6.3V, 20%, 10mW, ALUM.ELEC., ROHS	NIPPON CHEMI-CON	APXA6R3ARA681MJC0G
IHLP4040DZERR36M11	1	ea	L2	COIL-PWR INDUCTOR, SMD, 11.5x10.3, 0.36µH, 20%, 32A, ROHS	VISHAY	IHLP4040DZERR36M11
108-0740-001	4	ea	P1, P2 (2 EACH)	CONN-JACK, BANANA-SS-SDRLESS, VERTICAL, ROHS	JOHNSON COMPONENTS	108-0740-001
3-644456-4	1	ea	JP1	CONN-HEADER, 1x4, VERTICAL, TIN, WHT NYLON, ROHS	AMP/TYCO	3-644456-4
881545-2	2	ea	J2-Pins 1 and 2, JP1-Pins 3 and 4	CONN-JUMPER, SHUNT LP W/HANDLE, 2P, 2.54mm, BLK, ROHS	TYCO ELECTRONICS	881545-2
PJ-002A	1	ea	J3	CONN-POWER JACK, TH, 2.1mm, 16V@2.5A, BLK, R/A, ROHS	CUI, INC	PJ-002A
SSQ-105-02-T-D-RA	1	ea	J5	CONN-SOCKET STRIP, TH, 2x5, 2.54mm, TIN, R/A, ROHS	SAMTEC	SSQ-105-02-T-D-RA
TSW-102-07-F-S	0	ea	DNP (J6)	CONN-HEADER, 2x1, BRKAWY, 0.100, TH, GOLD FLASH, ROHS	SAMTEC	TSW-102-07-F-S
TSW-105-07-T-D	1	ea	J2	CONN-HEADER, 2x5, BRKAWY, 2.54mm, TIN, ROHS	SAMTEC	TSW-105-07-T-D
TSW-105-08-T-D-RA	1	ea	J4	CONN-HEADER, 2x5, BRKAWY, 2.54mm, TIN, R/A, ROHS	SAMTEC	TSW-105-08-T-D-RA
BAT54XV2T1G-T	3	ea	D3, D4, D5	DIODE-SCHOTTKY, SMD, 2P, SOD523, 30V, 200mA, ROHS	ON SEMICONDUCTOR	BAT54XV2T1G
MBR0540T1G-T	1	ea	D1	DIODE-RECTIFIER, SMD, SOD-123, 2P, 40V, 0.5A, ROHS	ON SEMICONDUCTOR	MBR0540T1G
STPS20L45CG	1	ea	D2	DIODE-RECTIFIER, SCHOTTKY, SMD, D2PAK, 45V, 10A, ROHS	STMICROELECTRONICS	STPS20L45CG
CMD17-21VGC/TR8-T	1	ea	D7	LED, SMD, 0805, GREEN, CLEAR, 10mcd, 2.1V, 20mA, 570nm, ROHS	CHICAGO MINIATURE	CMD17-21VGC/TR8
BLM18HD102SN1D-T	3	ea	L1, R18, R19	FERRITE CHIP, SMD, 0603, 1k, 100MHz, 50mA, ROHS	MURATA	BLM18HD102SN1D
ESDA6V1-4BC6	1	ea	D6	DIODE-TVS, ESD, QUAD BI-DIRECTIONAL, 6P, SOT23-6L, 80V, ROHS	STMICROELECTRONICS	ESDA6V1-4BC6
MIC2920A-3.3WS	1	ea	U2	IC-LDO REGULATOR, 4P, SOT-223, 3.3V, 400mA, ROHS	MICREL	MIC2920A-3.3WS
SN74AUP1G17DCKR	0	ea	DNP (U4)	IC-BUFFER, SCHMITT TRIGGER, 5P, SC-70-5, 3.6V, 4mA, ROHS	TEXAS INSTRUMENTS	SN74AUP1G17DCKR
SN74AUP1G17DCKR	1	ea	U3	IC-BUFFER, SCHMITT TRIGGER, 5P, SC-70-5, 3.6V, 4mA, ROHS	TEXAS INSTRUMENTS	SN74AUP1G17DCKR

Bill of Materials (Continued)

PART NUMBER	QTY	UNIT	REFERENCE DESIGNATOR	DESCRIPTION	MANUFACTURER	MANUFACTURER PART
ZL6100ALNFT	1	ea	U1	IC-DIGITAL DC/DC CONTROLLER, 36P, QFN, 6x6, ROHS	INTERSIL	ZL6100ALNFT
FDG6301N-T	2	ea	Q4, Q6	TRANSIST-MOS, DUAL N-CHANNEL, SMD, SC70-6, 25V, 220mA, ROHS	FAIRCHILD	FDG6301N
FDG6304P	1	ea	Q5	TRANSIST-MOS, DUAL P-CHANNEL, 6P, SC70-6, -25V, -0.41A, ROHS	FAIRCHILD	FDG6304P
FDMS8670AS	1	ea	Q3	TRANSISTOR-MOS, N-CHANNEL, 8P, POWER56, 30V, 42A, ROHS	FAIRCHILD	FDMS8670AS
FDMS8692	1	ea	Q2	TRANSISTOR-MOS, N-CHANNEL, 8P, POWER56, 30V, 28A, ROHS	FAIRCHILD	FDMS8692
MMBT3904LT1G-T	1	ea	Q1	TRANSISTOR, NPN, SOT-23, 3P, 40V, 0.2A, 0.35W, ROHS	ON SEMICONDUCTOR	MMBT3904LT1G-T
H2510-00R00-1/16W-T	1	ea	R4	RES, SMD, 0402, 0 Ω , 1/16 Ω , 5%, TF, ROHS	VENKEL	CR0402-16W-00T
H2510-01002-1/16W1-T	7	ea	R20, R21, R23, R26, R28, R29, R32	RES, SMD, 0402, 10k, 1/16W, 1%, TF, ROHS	PANASONIC	ERJ-2RKF1002X
H2510-01003-1/16W1-T	1	ea	R1	RES, SMD, 0402, 100k, 1/16W, 1%, TF, ROHS	PANASONIC	ERJ2RKF1003
H2510-01102-1/16W1-T	1	ea	R10	RES, SMD, 0402, 11k, 1/16W, 1%, TF, ROHS	PANASONIC	ERJ-2RKF1102V
H2510-01622-1/16W1-T	1	ea	R16	RES, SMD, 0402, 16.2k, 1/16W, 1%, TF, ROHS	PANASONIC	ERJ-2RKF1622
H2510-01962-1/16W1-T	1	ea	R11	RES, SMD, 0402, 19.6k, 1/16W, 1%, TF, ROHS	PANASONIC	ERJ-2RKF1962
H2510-02152-1/16W1-T	1	ea	R12	RES, SMD, 0402, 21.5k, 1/16W, 1%, TF, ROHS	PANASONIC	ERJ-2RKF2152X
H2510-02372-1/16W1-T	1	ea	R13	RES, SMD, 0402, 23.7k, 1/16W, 1%, TF, ROHS	PANASONIC	ERJ-2RKF2372V
H2510-02612-1/16W1-T	1	ea	R14	RES, SMD, 0402, 26.1k, 1/16W, 1%, TF, ROHS	VENKEL	CR0402-16W-2612FT
H2510-02872-1/16W1-T	1	ea	R15	RES, SMD, 0402, 28.7k, 1/16W, 1%, TF, ROHS	PANASONIC	ERJ-2RKF2872X
H2510-03482-1/16W1-T	1	ea	R17	RES, SMD, 0402, 34.8k, 1/16W, 1%, TF, ROHS	PANASONIC	ERJ-2RKF3482
H2510-04751-1/16W1-T	1	ea	R24	RES, SMD, 0402, 4.75k, 1/16W, 1%, TF, ROHS	PANASONIC	ERJ-2RKF4751X
H2510-DNP	0	ea	R34, R35	RES, SMD, 0402, DNP, DNP, DNP, TF, ROHS		
H2511-00R00-1/10W-T	1	ea	R5	RES, SMD, 0603, 0 Ω , 1/10W, TF, ROHS	VENKEL	CR0603-10W-000T
H2511-01821-1/10W1-T	1	ea	R7	RES, SMD, 0603, 1.82k, 1/10W, 1%, TF, ROHS	PANASONIC	ERJ-3EKF1821V
H2511-03920-1/10W1-T	2	ea	R27, R31	RES, SMD, 0603, 392 Ω , 1/10W, 1%, TF, ROHS	PANASONIC	ERJ-3EKF3920V
H2511-04990-1/10W1-T	1	ea	R6	RES, SMD, 0603, 499 Ω , 1/10W, 1%, TF, ROHS	KOA	RK73H1JTTD4990F
H2511-049R9-1/10W1-T	2	ea	R25, R30	RES, SMD, 0603, 49.9 Ω , 1/10W, 1%, TF, ROHS	VENKEL	CR0603-10W-49R9FT
H2511-DNP	0	ea	R33, R40-R47	RES, SMD, 0603, DNP-PLACE HOLDER, ROHS		
G13AP-RO	1	ea	SW1 (Note 1)	SWITCH-TOGGLE, THRU-HOLE, 5P, SPDT, 3POS, ON-OFF-ON, ROHS	NKK	G13AP-RO
4-40x1/4-SCREW-SS	4	ea		SCREW, 4-40x1/4in, PAN, SS, PHILLIPS		
4-40x3/4-STANDOFF-METAL	4	ea		STANDOFF, 4-40x3/4in, F/F, HEX, ALUMINUM, ROHS	KEYSTONE	2204 (0.250 OD)
VC-234-8	4	ea	P1, P2 (COVER BOTTOMS OF POST ENDS)	CAPLUG-ROUND VINYL CLOSURE, FLEXIBLE, 0.5x0.234, ROHS	CAPPLUGS	VC-234-8

NOTE:

- DO NOT CLEAN-INSTALL AFTER ASSY.

Default Configuration Text

The following text is loaded into the ZL6100 device on the ZL6100EVAL1Z as default settings. Each PMBus command is loaded via the PowerNavigator software. The # symbol is used for a comment line.

This configuration is intended for Zilker Labs ZL6100EV1

ZL Configuration File Revision 2

Schematic revision level

ZL Author B. KATES

Change log:

Notes: Fault responses are set to 0x80 which is fault once and shutdown

A fault response setting of 0xBF yields constant retry

RESTORE_FACTORY

STORE_USER_ALL

STORE_DEFAULT_ALL

MFR_ID

Zilker_Labs

MFR_MODEL

ZL6100EVAL1Z

MFR_REVISION

Rev2

MFR_LOCATION

Austin_TX

MFR_DATE

8/25/2009

VOUT_COMMAND

1.20

Advanced

VOUT_UV_FAULT_RESPONSE

0x80

USER_CONFIG

0x6010

VOUT_OV_FAULT_RESPONSE

0x80

MFR_CONFIG

0x6AD1

OVUV_CONFIG

0x80

NLR_CONFIG

0xE1060C00

TEMPCO_CONFIG

0xA8

IOUT_SCALE

0.9

Advanced 2

IOUT_CAL_OFFSET

0.5

MISC_CONFIG

0x0080

IOUT_OC_FAULT_LIMIT

45.0

DDC_CONFIG

0x0101

IOUT_AVG_OC_FAULT_LIMIT

38.0

DDC_GROUP

0x00000000

IOUT_UC_FAULT_LIMIT

-15.0

STORE_DEFAULT_ALL

IOUT_AVG_UC_FAULT_LIMIT

-12.0

RESTORE_DEFAULT_ALL

MFR_IOUT_OC_FAULT_RESPONSE

0x80

MFR_IOUT_UC_FAULT_RESPONSE

0x80

VIN_OV_FAULT_LIMIT

14.0

VIN_OV_WARN_LIMIT

13.5

VIN_OV_FAULT_RESPONSE

0x80

VIN_UV_WARN_LIMIT

4.641

VIN_UV_FAULT_LIMIT

4.50

VIN_UV_FAULT_RESPONSE

0x80

POWER_GOOD_DELAY

1

TON_DELAY

5

TON_RISE

5

TOFF_DELAY

5

TOFF_FALL

5

DEADTIME

0x2424

DEADTIME_CONFIG

0x0404

MAX_DUTY

95

INDUCTOR

0.4

FREQUENCY_SWITCH

400 # kHz

PID_TAPS

A= 13682.50, B= -23641.00, C= 9993.75

Measured Data

The following data was acquired using a ZL6100EVAL1Z Rev 2 evaluation board. Adaptive diode emulation and adaptive frequency modes are disabled for these efficiency measurements.

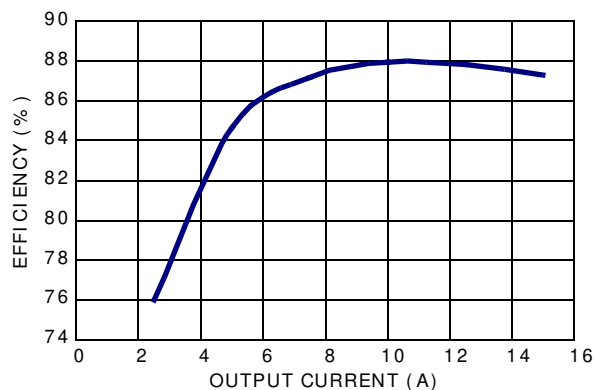

FIGURE 9. EFFICIENCY, $V_{IN} = 12V$, $V_{OUT} = 1.2V$

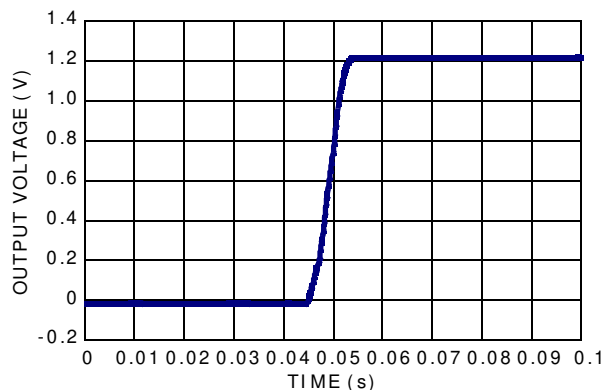

FIGURE 10. RAMP UP

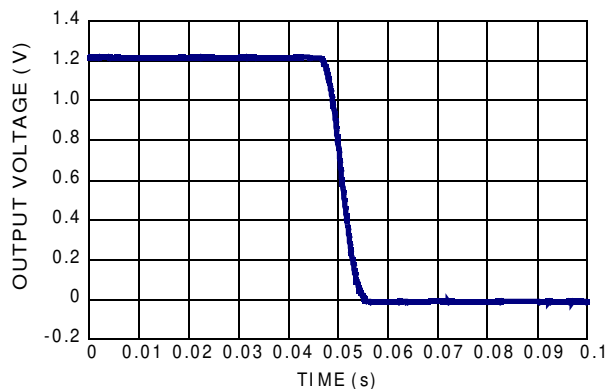

FIGURE 11. RAMP DOWN

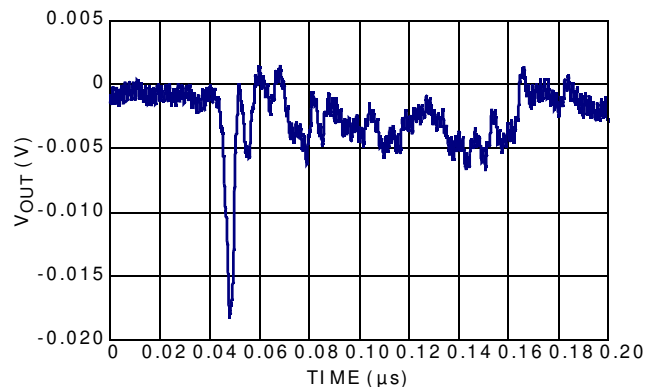

FIGURE 12. DYNAMIC RESPONSE, 7A TO 15A LOAD STEP

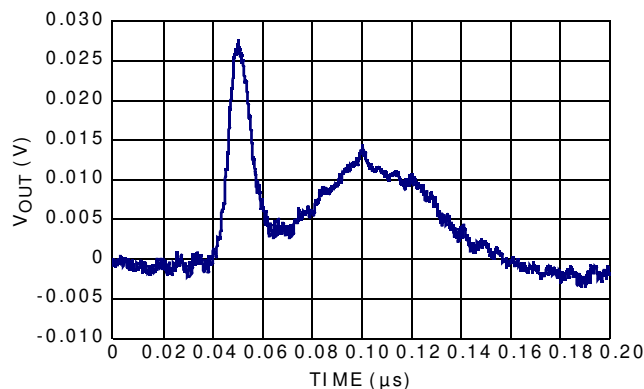

FIGURE 13. DYNAMIC RESPONSE, 15A TO 7A LOAD STEP

[2] ZL6100 Data Sheet, Zilker Labs, Inc., 2008.

[3] AN2033 – PMBus™ Command Set, Zilker Labs, Inc., 2008.

Revision History

The revision history provided is for informational purposes only and is believed to be accurate, but not warranted. Please go to web to make sure you have the latest Rev.

DATE	REVISION	CHANGE
08/14/09	AN1493.0	Converted to new Intersil template from Word document.

Notice

1. Descriptions of circuits, software and other related information in this document are provided only to illustrate the operation of semiconductor products and application examples. You are fully responsible for the incorporation or any other use of the circuits, software, and information in the design of your product or system. Renesas Electronics disclaims any and all liability for any losses and damages incurred by you or third parties arising from the use of these circuits, software, or information.
2. Renesas Electronics hereby expressly disclaims any warranties against and liability for infringement or any other claims involving patents, copyrights, or other intellectual property rights of third parties, by or arising from the use of Renesas Electronics products or technical information described in this document, including but not limited to, the product data, drawings, charts, programs, algorithms, and application examples.
3. No license, express, implied or otherwise, is granted hereby under any patents, copyrights or other intellectual property rights of Renesas Electronics or others.
4. You shall not alter, modify, copy, or reverse engineer any Renesas Electronics product, whether in whole or in part. Renesas Electronics disclaims any and all liability for any losses or damages incurred by you or third parties arising from such alteration, modification, copying or reverse engineering.
5. Renesas Electronics products are classified according to the following two quality grades: "Standard" and "High Quality". The intended applications for each Renesas Electronics product depends on the product's quality grade, as indicated below.
"Standard": Computers; office equipment; communications equipment; test and measurement equipment; audio and visual equipment; home electronic appliances; machine tools; personal electronic equipment; industrial robots; etc.
"High Quality": Transportation equipment (automobiles, trains, ships, etc.); traffic control (traffic lights); large-scale communication equipment; key financial terminal systems; safety control equipment; etc.
Unless expressly designated as a high reliability product or a product for harsh environments in a Renesas Electronics data sheet or other Renesas Electronics document, Renesas Electronics products are not intended or authorized for use in products or systems that may pose a direct threat to human life or bodily injury (artificial life support devices or systems; surgical implantations; etc.), or may cause serious property damage (space system; undersea repeaters; nuclear power control systems; aircraft control systems; key plant systems; military equipment; etc.). Renesas Electronics disclaims any and all liability for any damages or losses incurred by you or any third parties arising from the use of any Renesas Electronics product that is inconsistent with any Renesas Electronics data sheet, user's manual or other Renesas Electronics document.
6. When using Renesas Electronics products, refer to the latest product information (data sheets, user's manuals, application notes, "General Notes for Handling and Using Semiconductor Devices" in the reliability handbook, etc.), and ensure that usage conditions are within the ranges specified by Renesas Electronics with respect to maximum ratings, operating power supply voltage range, heat dissipation characteristics, installation, etc. Renesas Electronics disclaims any and all liability for any malfunctions, failure or accident arising out of the use of Renesas Electronics products outside of such specified ranges.
7. Although Renesas Electronics endeavors to improve the quality and reliability of Renesas Electronics products, semiconductor products have specific characteristics, such as the occurrence of failure at a certain rate and malfunctions under certain use conditions. Unless designated as a high reliability product or a product for harsh environments in a Renesas Electronics data sheet or other Renesas Electronics document, Renesas Electronics products are not subject to radiation resistance design. You are responsible for implementing safety measures to guard against the possibility of bodily injury, injury or damage caused by fire, and/or danger to the public in the event of a failure or malfunction of Renesas Electronics products, such as safety design for hardware and software, including but not limited to redundancy, fire control and malfunction prevention, appropriate treatment for aging degradation or any other appropriate measures. Because the evaluation of microcomputer software alone is very difficult and impractical, you are responsible for evaluating the safety of the final products or systems manufactured by you.
8. Please contact a Renesas Electronics sales office for details as to environmental matters such as the environmental compatibility of each Renesas Electronics product. You are responsible for carefully and sufficiently investigating applicable laws and regulations that regulate the inclusion or use of controlled substances, including without limitation, the EU RoHS Directive, and using Renesas Electronics products in compliance with all these applicable laws and regulations. Renesas Electronics disclaims any and all liability for damages or losses occurring as a result of your noncompliance with applicable laws and regulations.
9. Renesas Electronics products and technologies shall not be used for or incorporated into any products or systems whose manufacture, use, or sale is prohibited under any applicable domestic or foreign laws or regulations. You shall comply with any applicable export control laws and regulations promulgated and administered by the governments of any countries asserting jurisdiction over the parties or transactions.
10. It is the responsibility of the buyer or distributor of Renesas Electronics products, or any other party who distributes, disposes of, or otherwise sells or transfers the product to a third party, to notify such third party in advance of the contents and conditions set forth in this document.
11. This document shall not be reprinted, reproduced or duplicated in any form, in whole or in part, without prior written consent of Renesas Electronics.
12. Please contact a Renesas Electronics sales office if you have any questions regarding the information contained in this document or Renesas Electronics products.
(Note 1) "Renesas Electronics" as used in this document means Renesas Electronics Corporation and also includes its directly or indirectly controlled subsidiaries.
(Note 2) "Renesas Electronics product(s)" means any product developed or manufactured by or for Renesas Electronics.

(Rev.4.0-1 November 2017)



SALES OFFICES

Renesas Electronics Corporation

<http://www.renesas.com>

Refer to "<http://www.renesas.com/>" for the latest and detailed information.

Renesas Electronics America Inc.
1001 Murphy Ranch Road, Milpitas, CA 95035, U.S.A.
Tel: +1-408-432-8888, Fax: +1-408-434-5351

Renesas Electronics Canada Limited
9251 Yonge Street, Suite 8309 Richmond Hill, Ontario Canada L4C 9T3
Tel: +1-905-237-2004

Renesas Electronics Europe Limited
Dukes Meadow, Millboard Road, Bourne End, Buckinghamshire, SL8 5FH, U.K
Tel: +44-1628-651-700, Fax: +44-1628-651-804

Renesas Electronics Europe GmbH
Arcadiastrasse 10, 40472 Düsseldorf, Germany
Tel: +49-211-6503-0, Fax: +49-211-6503-1327

Renesas Electronics (China) Co., Ltd.
Room 1709 Quantum Plaza, No.27 ZhichunLu, Haidian District, Beijing, 100191 P. R. China
Tel: +86-10-8235-1155, Fax: +86-10-8235-7679

Renesas Electronics (Shanghai) Co., Ltd.
Unit 301, Tower A, Central Towers, 555 Langao Road, Putuo District, Shanghai, 200333 P. R. China
Tel: +86-21-2226-0888, Fax: +86-21-2226-0999

Renesas Electronics Hong Kong Limited
Unit 1601-1611, 16/F., Tower 2, Grand Century Place, 193 Prince Edward Road West, Mongkok, Kowloon, Hong Kong
Tel: +852-2265-6688, Fax: +852-2886-9022

Renesas Electronics Taiwan Co., Ltd.
13F, No. 363, Fu Shing North Road, Taipei 10543, Taiwan
Tel: +886-2-8175-9600, Fax: +886-2-8175-9670

Renesas Electronics Singapore Pte. Ltd.
80 Bendemeer Road, Unit #06-02 Hyflux Innovation Centre, Singapore 339949
Tel: +65-6213-0200, Fax: +65-6213-0300

Renesas Electronics Malaysia Sdn.Bhd.
Unit 1207, Block B, Menara Amcorp, Amcorp Trade Centre, No. 18, Jln Persiaran Barat, 46050 Petaling Jaya, Selangor Darul Ehsan, Malaysia
Tel: +60-3-7955-9390, Fax: +60-3-7955-9510

Renesas Electronics India Pvt. Ltd.
No.777C, 100 Feet Road, HAL 2nd Stage, Indiranagar, Bangalore 560 038, India
Tel: +91-80-67208700, Fax: +91-80-67208777

Renesas Electronics Korea Co., Ltd.
17F, KAMCO Yangjae Tower, 262, Gangnam-daero, Gangnam-gu, Seoul, 06265 Korea
Tel: +82-2-558-3737, Fax: +82-2-558-5338