

**Circuits
from the Lab®**
Reference Designs

Circuits from the Lab® reference designs are engineered and tested for quick and easy system integration to help solve today's analog, mixed-signal, and RF design challenges. For more information and/or support, visit www.analog.com/CN0388.

Devices Connected/Referenced

ADN4651	5 kV RMS, 600 Mbps, Dual-Channel LVDS Isolator
AD7960	18-Bit, 5 MSPS PulSAR Differential ADC
ADuM4400	5 kV RMS Quad-Channel Digital Isolator
ADuM2251	Hot Swappable, Dual I2C Isolators, 5 kV

Isolated 600 Mbps, LVDS, 18-Bit, 5 MSPS Data Acquisition System

EVALUATION AND DESIGN SUPPORT

Circuit Evaluation Boards

[CN-0388 Circuit Evaluation Board \(EVAL-CN0388-FMCZ\)](#)

[AD7960 Evaluation Board \(EVAL-AD7960-FMCZ\)](#)

[SDP-H1 System Demonstration Platform, High Speed \(EVAL-SDP-CH1Z\)](#)

Design and Integration Files

[Schematics, Layout Files, Bill of Materials](#)

CIRCUIT FUNCTION AND BENEFITS

The circuit shown in Figure 1 demonstrates isolation of an analog front end (18-bit, 5 MSPS [AD7960](#) analog-to-digital converter (ADC)) at 600 Mbps using the [ADN4651](#) LVDS isolator. An interposer board with the [ADN4651](#) connects to the standard [AD7960](#) evaluation platform, isolating the analog front end board from the high speed SDP-H1 system demonstration platform ([EVAL-SDP-CH1Z](#)). The SDP-H1 contains a Xilinx Spartan 6 FPGA to capture acquisitions and a [ADSP-BF527](#) DSP to communicate with the PC.

Galvanic isolation of external interfaces is required in harsh environments for safety, functionality, or improved noise immunity. This includes analog front ends used in data

acquisition modules for industrial measurement and control. Bandwidth requirements for converter interfaces are increasing, as trends such as Industry 4.0 and the Internet of Things (IoT) demand far more ubiquitous measurement and control, with greater speed and precision. This poses a challenge for isolation, because even standard digital isolators are limited to 150 Mbps operation.

For measurement and control applications in industrial environments, the benefits of such an isolated analog front-end implementation include:

- Ease of design due to the drop-in LVDS isolator with fully compliant input/output and ultralow jitter.
- High bandwidth of 600 Mbps to support increased ADC resolution and speed.
- Galvanic isolation for protection from mains voltages, isolated measurement of power supplies, or noise immunity from digital or power supply circuits.

The circuit in Figure 1 demonstrates an industry-leading solution to LVDS isolation at 600 Mbps using the [ADN4651](#) dual-channel isolator.

Rev. 0

Circuits from the Lab® reference designs from Analog Devices have been designed and built by Analog Devices engineers. Standard engineering practices have been employed in the design and construction of each circuit, and their function and performance have been tested and verified in a lab environment at room temperature. However, you are solely responsible for testing the circuit and determining its suitability and applicability for your use and application. Accordingly, in no event shall Analog Devices be liable for direct, indirect, special, incidental, consequential or punitive damages due to any cause whatsoever connected to the use of any Circuits from the Lab circuits. (Continued on last page)

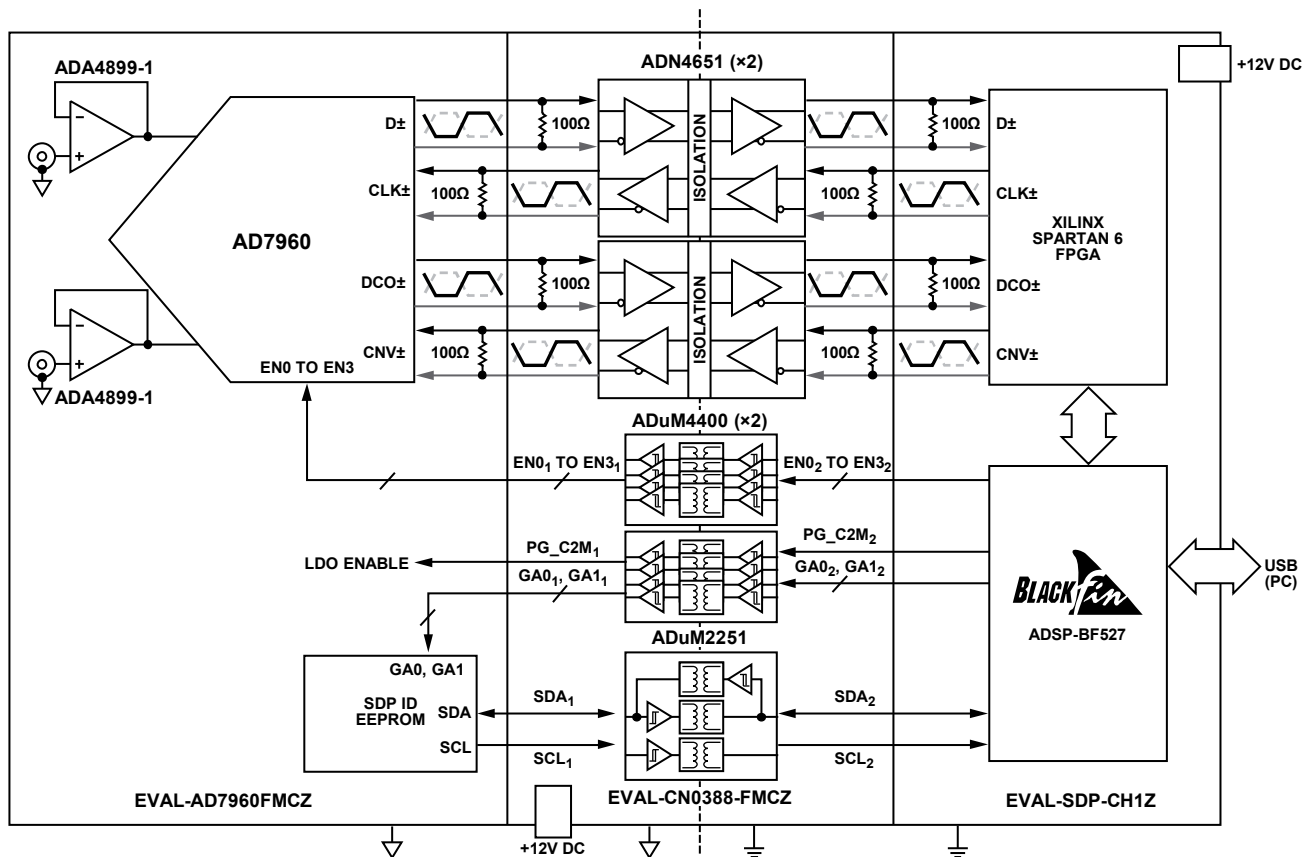

Figure 1. EVAL-AD7960FMCZ and EVAL-SDP-CH1Z Isolated with ADN4651 EVAL-CN0388-FMCZ Interposer Board

CIRCUIT DESCRIPTION

The interposer circuit relies upon two [ADN4651](#) 600 Mbps LVDS isolators to isolate the LVDS interface to the [AD7960](#). As shown in Figure 1, two LVDS clocks are sent from the Spartan 6 FPGA to the [AD7960](#); the 5 MHz sample clock (CNV \pm) and a 300 MHz reference clock (CLK \pm). The [AD7960](#) uses the 300 MHz reference to clock out bursts of sample data at 600 Mbps on D \pm , synchronous with an echoed 300 MHz clock (DCO \pm). D \pm is idle after each data burst to avoid interfering with the acquisition phase of the converter. The [ADN4651](#) houses a pair of bidirectional digital isolators that integrate Analog Devices, Inc., iCoupler[®] technology to operate at high speed with very low jitter. The VIN+ and VIN- ac voltage inputs are passed through two separate [ADA4899-1](#) unity-gain stable voltage feedback op amps to which their corresponding outputs are fed into the [AD7960](#). The differential signal of the two input signals then undergoes analog-to-digital conversion and is sent out via D \pm , synchronized to DCO \pm .

The Blackfin[®] [ADSP-BF527](#) outputs the appropriate logic high and logic low levels using 1.8 V logic only through the [ADuM4400](#) quad digital isolators to the [AD7960](#) enable pins (EN0 to EN3), as well as the on-board LDO enable (PC_C2M) and the SDP ID EEPROM address (GA0, GA1). The enable pins on the [AD7960](#) can be configured to specific operational requirements. Full information is available in the [AD7960](#) data sheet. The [ADuM2251](#) dual I²C isolator isolates the SDP ID

EEPROM clock (SCL) and data (SDA) from the Blackfin [ADSP-BF527](#) interface.

Communications between the Blackfin [ADSP-BF527](#) and Spartan 6 FPGA to the interposer and measurement circuits are controlled through the USB port on the [EVAL-SDP-CH1Z](#) to the evaluation software installed on a PC as shown in Figure 1.

The circuit is powered on the logic and bus side by two 12 V dc supplies, where four supply rails are generated on the [EVAL-AD7960FMCZ](#) and three supply rails are generated on the [EVAL-CN0388-FMCZ](#). On the [EVAL-AD7960FMCZ](#), the [ADP7104](#) CMOS LDO produces 5 V, the [ADP7102](#) CMOS LDO produces 7 V, the [ADP2300](#) nonsynchronous step-down regulator produces -2.5 V, and the [ADP124](#) CMOS linear regulator produces 1.8 V. On the [EVAL-CN0388-FMCZ](#), the [ADP3335](#) produces 5 V, the [ADP151](#) linear regulator (2.5 V version) produces 2.5 V, and the [ADP151](#) linear regulator (3.3 V version) produces 3.3 V.

As shown in Figure 1, termination resistors of 100 Ω are fitted on each LVDS input and output of the two [ADN4651](#) isolators at CNV \pm , CLK \pm , D \pm , and DCO \pm (R11, R12, R13, and R14).

Power and ground on both the logic and bus sides are connected via a barrel connector. Logic levels, clocks, and data signals are connected throughout the [EVAL-AD7960FMCZ](#), [EVAL-CN0388-FMCZ](#), and [EVAL-SDP-CH1Z](#) via traces to

FMC connectors configured as shown in Figure 2. The ac voltage inputs (VIN+/VIN-) are connected via SMA connectors. An Audio Precision source is an ideal differential driver for the inputs. The user also has the option to apply an external voltage reference to [EVAL-AD7960FMCZ](#) via a screw-wire connector.

A complete documentation package including detailed schematics, bill of materials, and layout can be found in the [CN-0388 Design Support Package](#) at www.analog.com/CN0388-DesignSupport.



Figure 2. [EVAL-AD7960FMCZ](#), [EVAL-CN0388-FMCZ](#) Isolator, and [EVAL-SDP-CH1Z](#) Boards Connected Together

13787-002

CIRCUIT EVALUATION AND TEST

Before starting evaluation, install the [EVAL-AD7960FMCZ](#) evaluation software on a PC. Software installation instructions can be found in the [EVAL-AD7960FMCZ User Guide \(UG-490\)](#).

To begin testing, ensure that the [EVAL-AD7960FMCZ](#), [EVAL-CN0388-FMCZ](#), and [EVAL-SDP-CH1Z](#) boards are connected correctly using their FMC connectors. This configuration is shown in Figure 3. To power the [EVAL-AD7960FMCZ](#), [EVAL-CN0388-FMCZ](#), and [EVAL-SDP-CH1Z](#), connect a wall wart power supply to the barrel connectors on the [EVAL-CN0388-FMCZ](#) and [EVAL-SDP-CH1Z](#). If the correct voltage levels have been supplied, the +12V_FMC LED ([EVAL-AD7960FMCZ](#)), the LED_1 and LED_2 LEDs ([EVAL-CN0388-FMCZ](#)), and the FMC_PWR_GD LED ([EVAL-SDP-CH1Z](#)) are lit. Alternatively, to test that the circuit is powered correctly, check the voltage levels on the corresponding voltage test points on each board.

The labels on each of these test points must match their measured values. On the [EVAL-CN0388-FMCZ](#), there are three voltage test points on each of the isolated and nonisolated sides; +3_3V_SIDE1/SIDE2, +2_5V_SIDE1ADP1/SIDE2, and +12V_IN/IN2. There are four voltage test points on the [EVAL-AD7960FMCZ](#): +7 V, +5 V, +12 V, and V_{REF}.

A complete high speed analog to digital conversion can be tested by connecting differential ac voltage sources through VIN- and VIN+ via the SMA connectors ranging between -V_{REF} and +V_{REF} (after the voltage sources). Acquisition data from the differential input is sent by the [EVAL-AD7960FMCZ](#) to the evaluation software installed on the PC. Refer to the [EVAL-AD7960FMCZ User Guide \(UG-490\)](#) for hardware and software operation. Figure 4 shows the **Summary** tab within the [EVAL-AD7960FMCZ](#) evaluation software, which displays a summary of the information gathered.

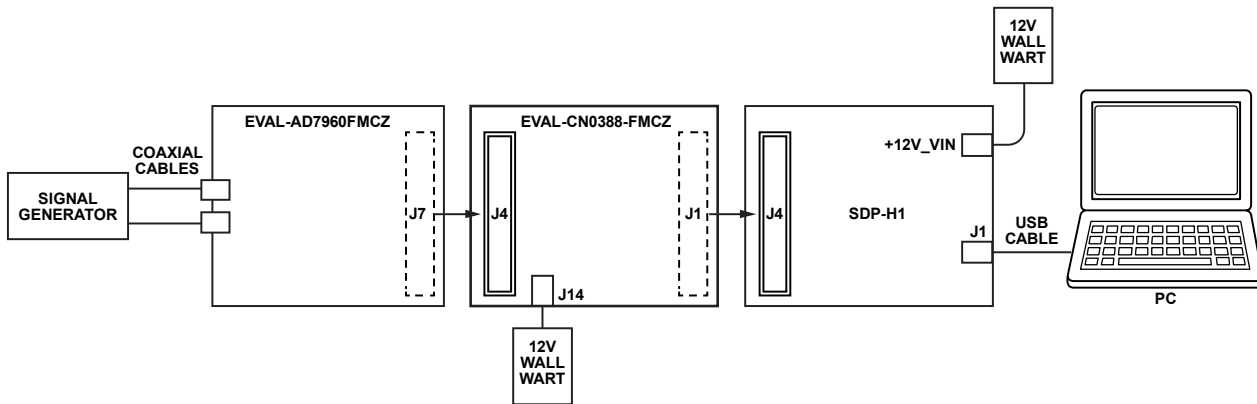

Figure 3. Isolated Analog-to-Digital Data Acquisition Test Setup

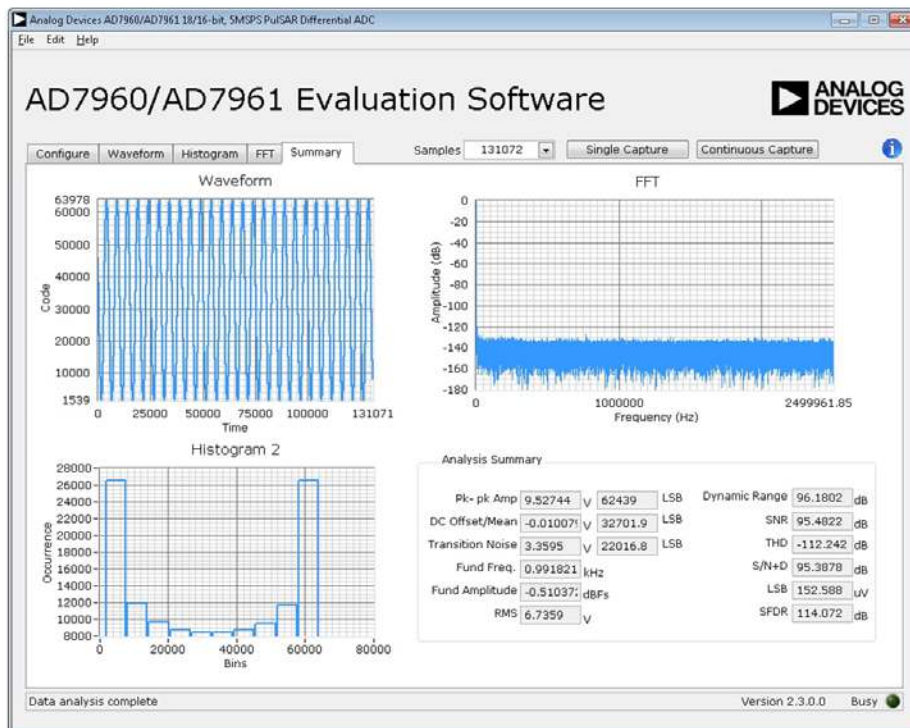

Figure 4. EVAL-AD7960FMCZ Evaluation Software Window

13787-003

13787-004

LEARN MORE

CN-0388 Design Support Package:

www.analog.com/CN0388-DesignSupport

[EVAL-AD7960FMCZ Evaluation Board User Guide \(UG-490\)](#)

[SDP EVAL-SDP-CH1Z Evaluation Board User Guide \(UG-502\)](#)

Cantrell, Mark. Application Note AN-0971. *Recommendations for Control of Radiated Emissions with isoPower Devices*. Analog Devices.

Chen, Baoxing. *iCoupler® Products with isoPower™ Technology: Signal and Power Transfer Across Isolation Barrier Using Microtransformers*. Analog Devices, 2006.

Data Sheets and Evaluation Boards

[ADN4651 Data Sheet](#)

[AD7960 Data Sheet](#)

[ADuM4400 Data Sheet](#)

[ADuM2251 Data Sheet](#)

REVISION HISTORY

9/2016—Revision 0: Initial Version

(Continued from first page) Circuits from the Lab reference designs are intended only for use with Analog Devices products and are the intellectual property of Analog Devices or its licensors. While you may use the Circuits from the Lab reference designs in the design of your product, no other license is granted by implication or otherwise under any patents or other intellectual property by application or use of the Circuits from the Lab reference designs. Information furnished by Analog Devices is believed to be accurate and reliable. However, Circuits from the Lab reference designs are supplied "as is" and without warranties of any kind, express, implied, or statutory including, but not limited to, any implied warranty of merchantability, noninfringement or fitness for a particular purpose and no responsibility is assumed by Analog Devices for their use, nor for any infringements of patents or other rights of third parties that may result from their use. Analog Devices reserves the right to change any Circuits from the Lab reference designs at any time without notice but is under no obligation to do so.

©2016 Analog Devices, Inc. All rights reserved. Trademarks and registered trademarks are the property of their respective owners.
CN13787-0-9/16(0)

