

NOTICE OF PROPRIETARY RIGHTS THIS DOCUMENT CONTAINS CONFIDENTIAL TECHNICAL DATA, INCLUDING TRADE SECRETS, PROPRIETARY TO TIMES MICROWAVE SYSTEMS. DISCLOSURE OF THIS DATA IS EXPRESSLY CONDITIONED UPON YOUR ASSENT THAT ITS USE IS LIMITED TO USE WITHIN YOUR COMPANY ONLY. ANY OTHER USE IS STRICTLY PROHIBITED WITHOUT THE PRIOR WRITTEN CONSENT OF TIMES MICROWAVE SYSTEMS.

SYM	REVISION DESCRIPTION	DFTM	DATE	APPD	DATE
A	RELEASED FOR PRODUCTION	D. J. H.	10/17/13	J. D. B.	10/21/13
B	CHANGED PER CDC #43318	N. N. N.	11/4/15	J. D. B.	12/11/15

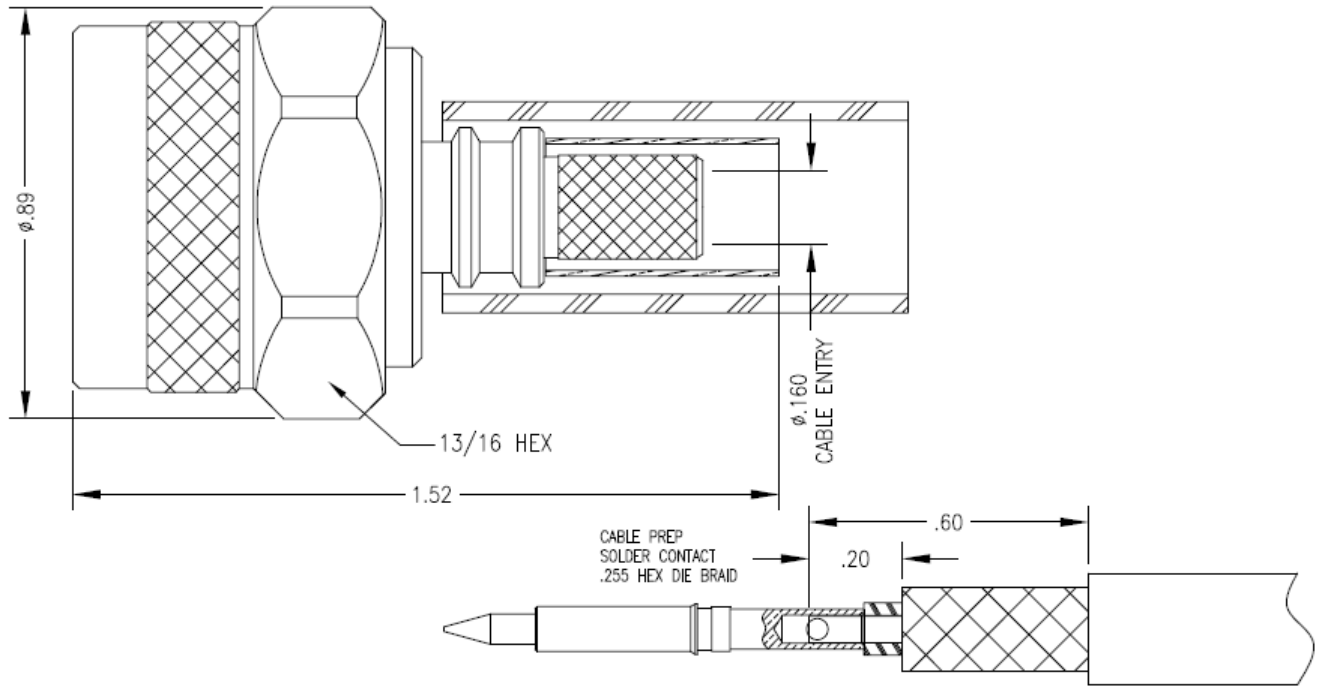

- | | | |
|----------------------------------------|----------------------------------------|-------------------------------|
| 1.0 PERFORMANCE | 2.0 MATERIALS | 3.0 FINISHES: SEE TABLE |
| 1.1 FREQUENCY RANGE: DC-6 GHz | 2.1 DIELECTRIC: PTFE/REXOLYTE | 4.0 MECHANICAL |
| 1.2 NOMINAL IMPEDANCE: 50 OHMS | 2.2 CONTACT: BRASS | 4.1 INTERFACE PER MIL-STD-348 |
| 1.3 DWV: 750 VRMS @ 60 Hz (SEA LEVEL) | 2.3 LOCKING RING: PHOSPHOR BRONZE | |
| 1.4 TEMPERATURE RANGE: -65°C TO +165°C | 2.4 CRIMP FERRULE: SOFT COPPER | |
| | 2.5 OTHER METAL PARTS: BRASS | |
| | 2.6 GASKET: SILICONE RUBBER | |
| | 2.7 HEAT SHRINK: POLYOLEFIN THICK WALL | |

BODY	CONTACT
ALBALOY	GOLD/NI

MATL:	UNLESS OTHERWISE SPECIFIED ALL DIMENSIONS ARE IN INCHES MACHINED SURFACES FINISH N/A RMS MAX. REMOVE ALL BURRS .005 MAX. BREAK MACHINE CORNERS .005 MAX. FILLET R. TOLERANCES ON DECIMALS . XX ± .03 . XXX ± .005 ANGLES ± 1° FRACTIONS ± 1/32	DFTM. D. J. H.	TIMES MICROWAVE SYSTEMS
		DATE 10/17/13	
USED ON: C		CHKD. J. D. B.	TC-240-NMH-X N MALE FOR LMR-240 CABLE SOLDER/CRIMP/NO BRAID TRIM
		DATE 10/21/13	
SCALE: N/A	DWG. SIZE A	APPD. J. D. B.	1 of 1 SD3190-2887 B
		DO NOT SCALE DRAWING	
	CODE IDENT 68999	DATE 10/21/13	