

SPEAKER-916-3-SC-FOX

The 9 x 16 x 3 mm Rectangular Fox speaker is a high end miniature speaker specifically designed for portable devices, music phones and smartphones where high quality sound is required.

Production on fully automated manufacturing lines guarantees consistent high quality in large volumes.

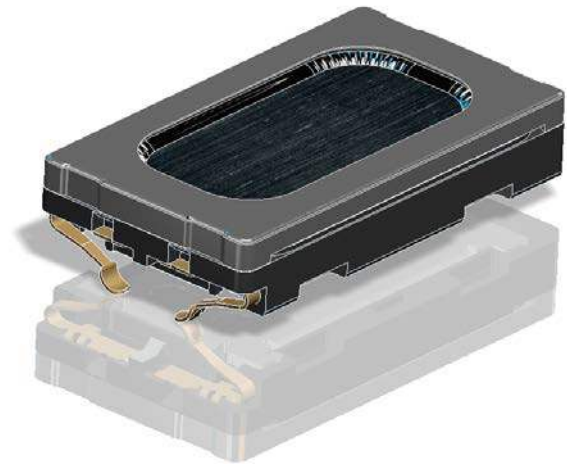

Features:

- Industry-leading dimensions: 9 x 16 x 3.0 mm
- Optimized for use in mobile handsets
- Maximum power handling capacity: 500 mW
- Extremely robust spring connector
- Manufactured to the highest standards
- 100% in-line measurement of all specified acoustical and electrical parameters

Contents

1. Theory of operation.....	3
2. Mechanical Layout and Dimensions.....	4
2.1. Main Dimensions.....	4
2.2. PWB Layout	5
2.3. Spring Force.....	5
2.4. Forces on Component	6
2.5. Part Marking/Labeling.....	7
2.6. Material List.....	8
3. Electrical and Acoustical Specifications.....	9
3.1. Frequency response	9
3.2. THD Response.....	10
3.3. Electro-Acoustic Parameters	11
3.4. Power Handling	11
3.5. Measurement Setup.....	12
3.6. Measured Parameters.....	12
3.7. Measurement adapter	13
4. Environmental Conditions.....	14
4.1. Storage.....	14
4.2. Transportation.....	14
4.3. Functionality.....	14
5. Environmental tests	15
5.1. Qualification tests.....	15
5.2. Reliability tests	15
5.3. Sample Size, Sequence	15
5.4. Period of Shelf-Life	15
5.5. Testing Procedures.....	15
6. Related Documents	19
7. Change History	20
8. Disclaimer	20

2403 260 00086

1. Theory of operation

SPEAKER-916-3-SC-FOX The Fox is a high end micro size speaker specifically designed for mobile phone and other applications where high quality sound is needed and only very little space for components is available.

2403 260 00086

2. Mechanical Layout and Dimensions

2.1. Main Dimensions

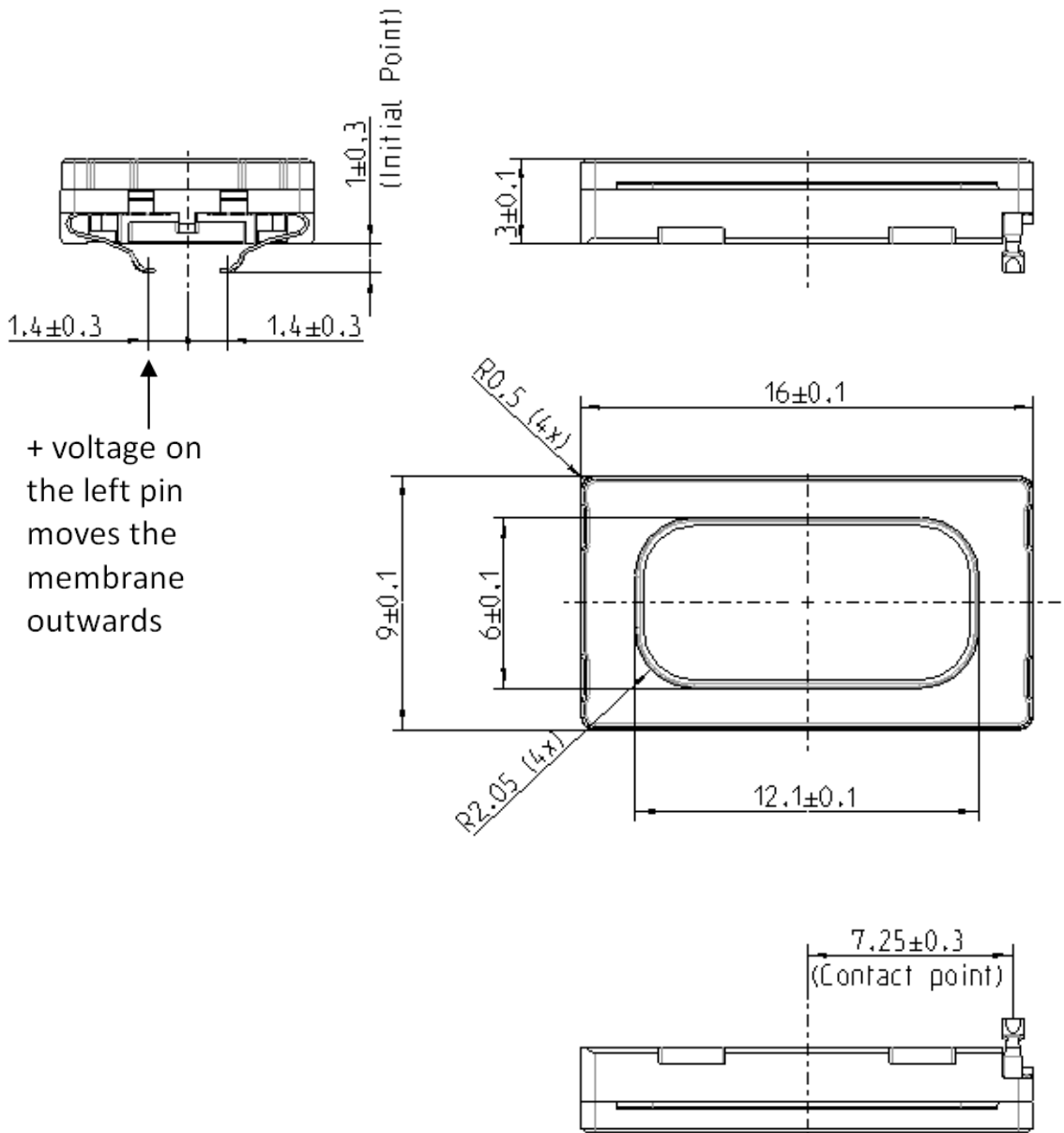

2403 260 00086

2.2. PWB Layout

PAD LAYOUT (VIEW TO PWB / TOPSIDE)

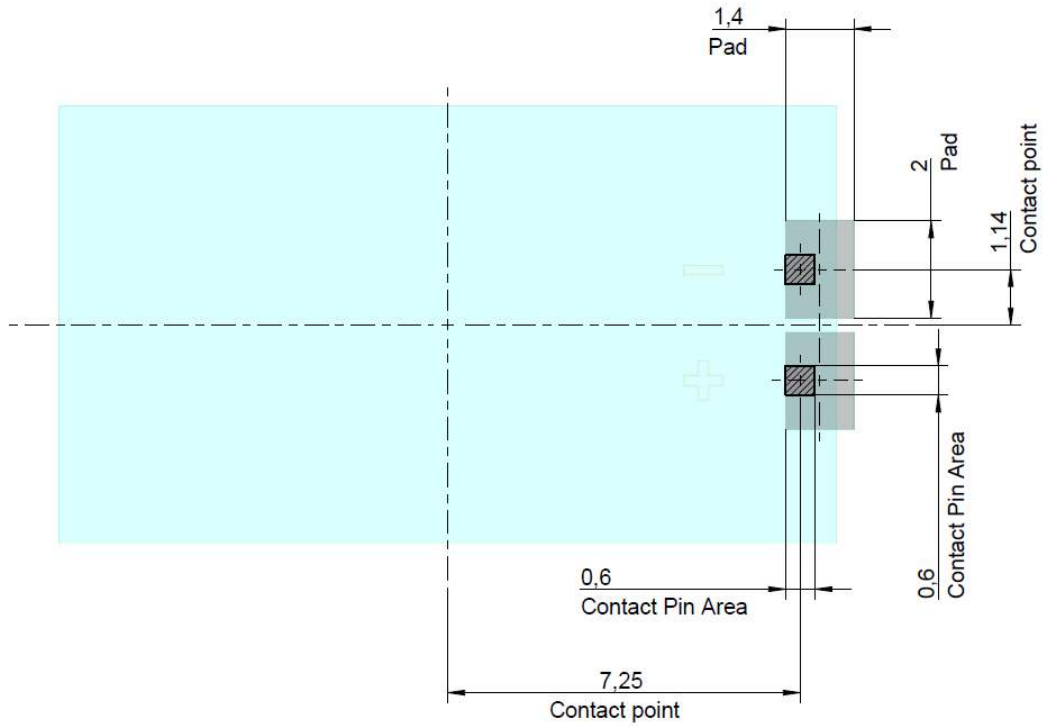

2.3. Spring Force

RA 9x16x3 springforce

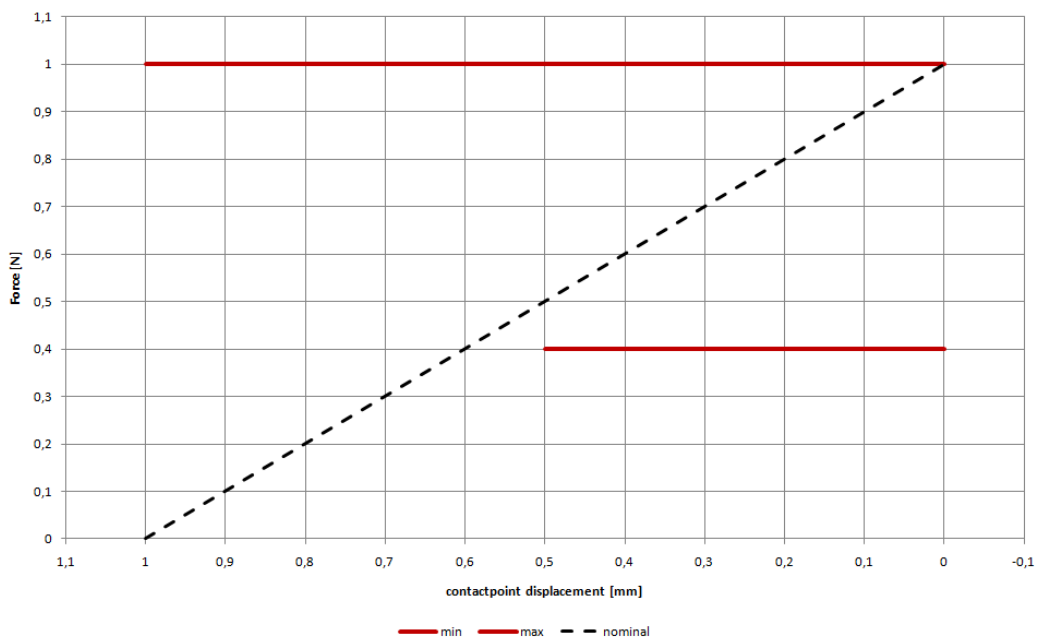

2403 260 00086

2.4. Forces on Component

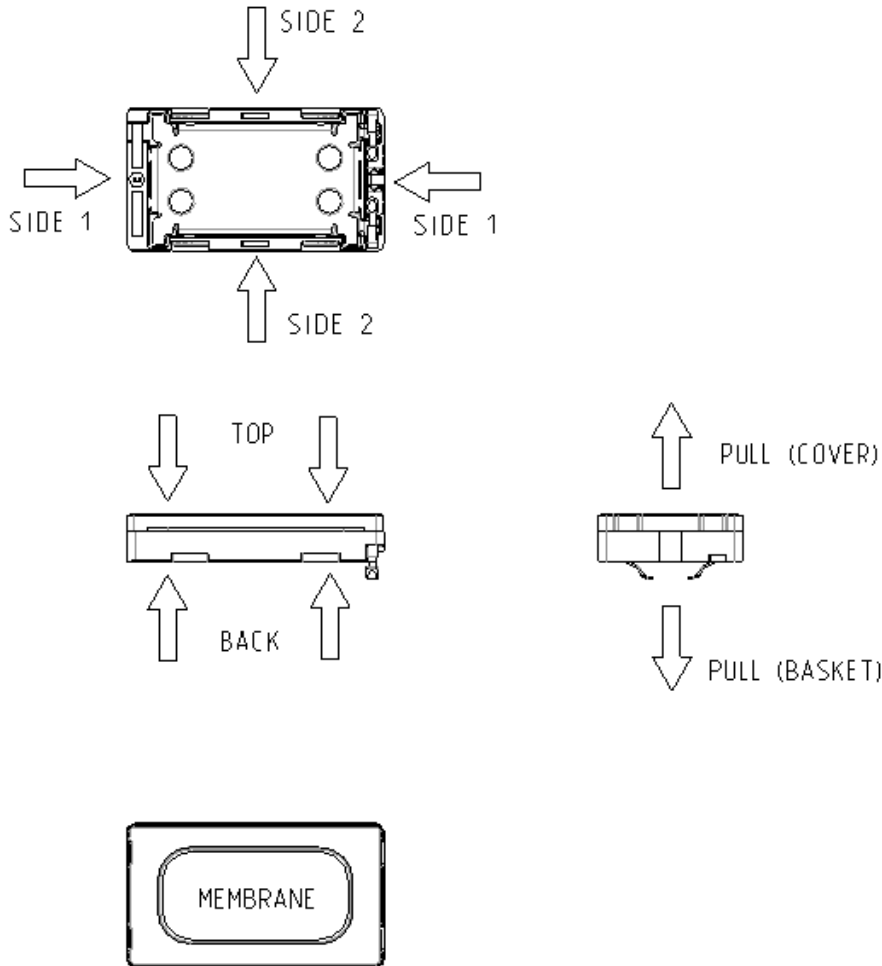

STATE	MINIMUM SURFACE OF PRESSURE [mm ²]	MAXIMUM PERMANENT FORCE [N]	MAXIMUM HANDLING FORCE [N]
FROM FRONT (DISTRIBUTED TO GASKET AREA TO BACK (BASKET))	-	10	15
FROM SIDE 1 TO SIDE 1	3	10	15
FROM SIDE 2 TO SIDE 2	10	10	15
TO POT	-	10	15
TO MEMBRANE	-	0	0
PULL OFF FORCE (COVER/BASKET)	-	-	10

2403 260 00086

2.5. Part Marking/Labeling

The products have a serial number on bottom side

Semi Line:

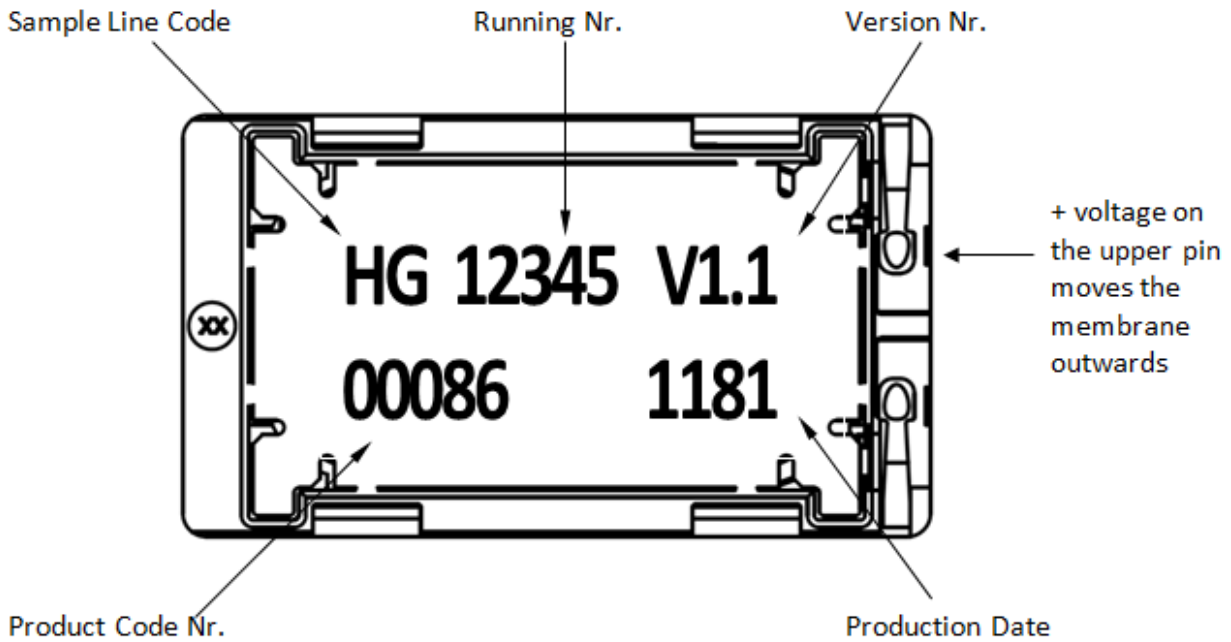

Auto Line:

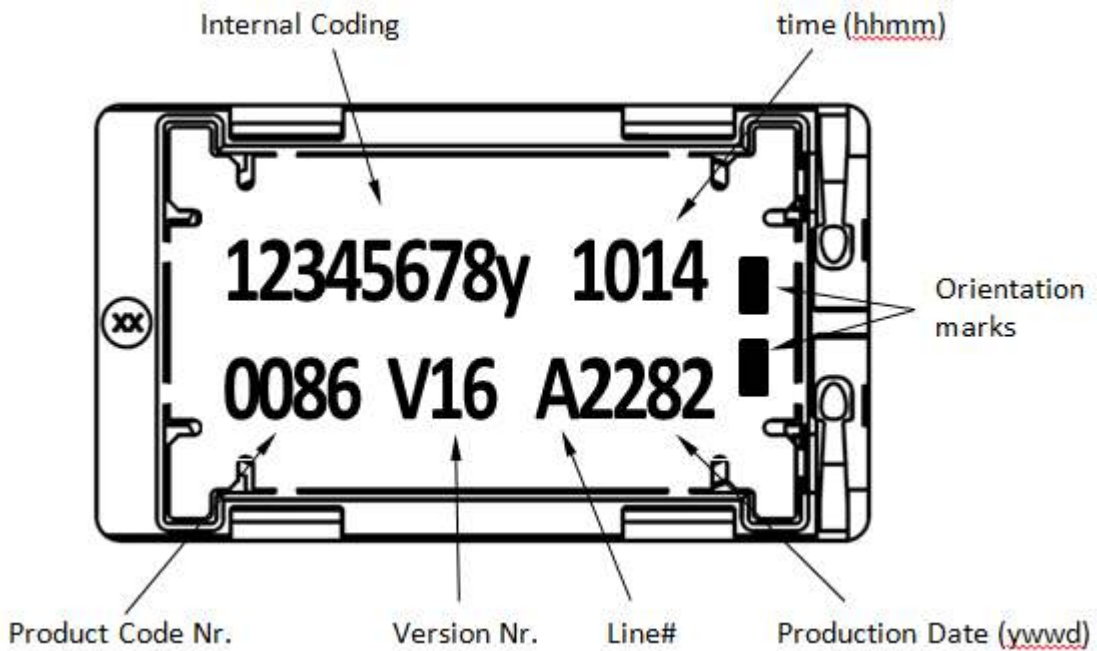

2403 260 00086

2.6. Material List

- | | |
|--------------------------|------------------------------------|
| 1. Material of basket: | Polycarbonate |
| 2. Material of membrane: | Polyethylene Naphthalene -Compound |
| 3. Material of pot: | soft magnetic Iron |
| 4. Material of magnet: | Nd Fe B |
| 5. Material of contact | CrNi-Steel, gold plated |
| 6. Material of cover: | Polycarbonate |
| 7. Dimensions: | 9x16x3.0mm |
| 8. Mass: | 0.55g |

2403 260 00086

3. Electrical and Acoustical Specifications

Typical frequency response measured on baffle acc. Chapter 3.6
(distance $d=10\text{cm}$, with back cavity 1cm^3 at 500mW)

3.1. Frequency response

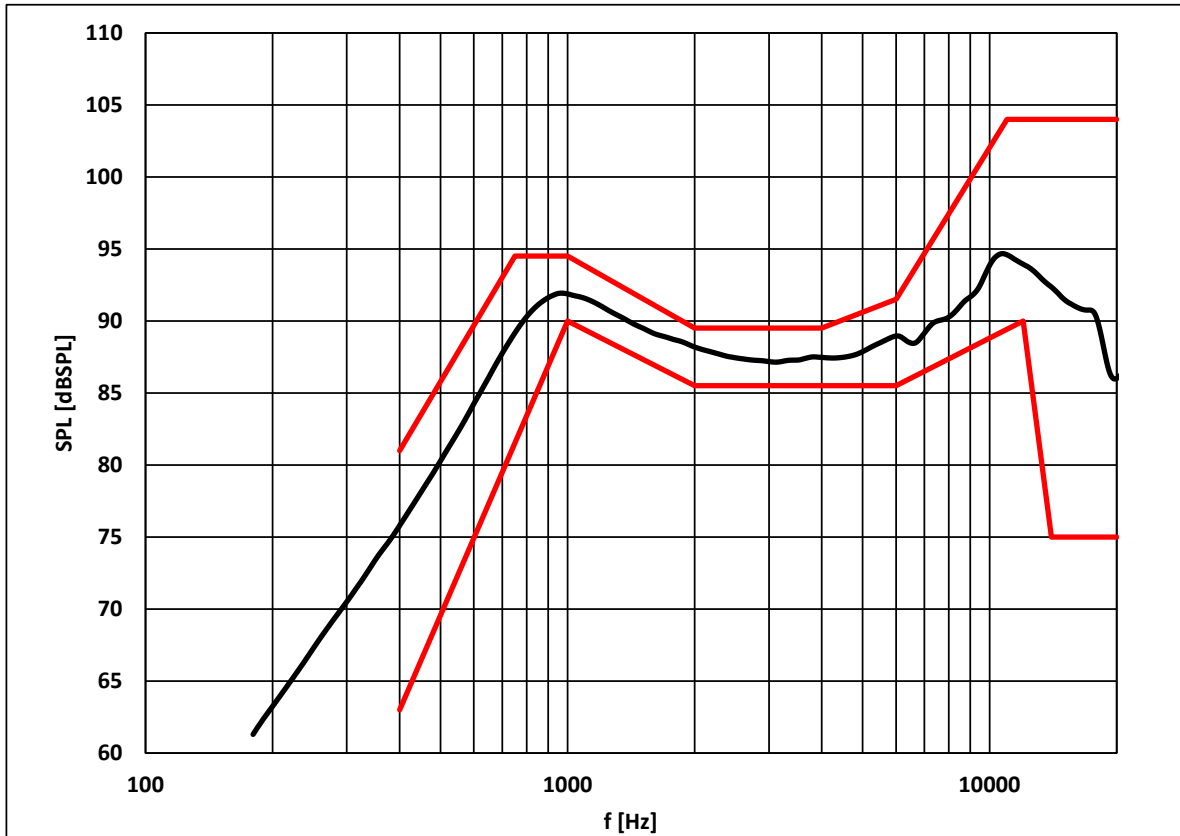

SPL tolerance window			
f [Hz]	lower limit [dB SPL]	f [Hz]	upper limit [dB SPL]
400	63	400	81
1000	90	750	94.5
2000	85.5	1000	94.5
6000	85.5	2000	89.5
12000	90	4000	89.5
14000	75	6000	91.5
20000	75	11000	104
		20000	104

3.2. THD Response

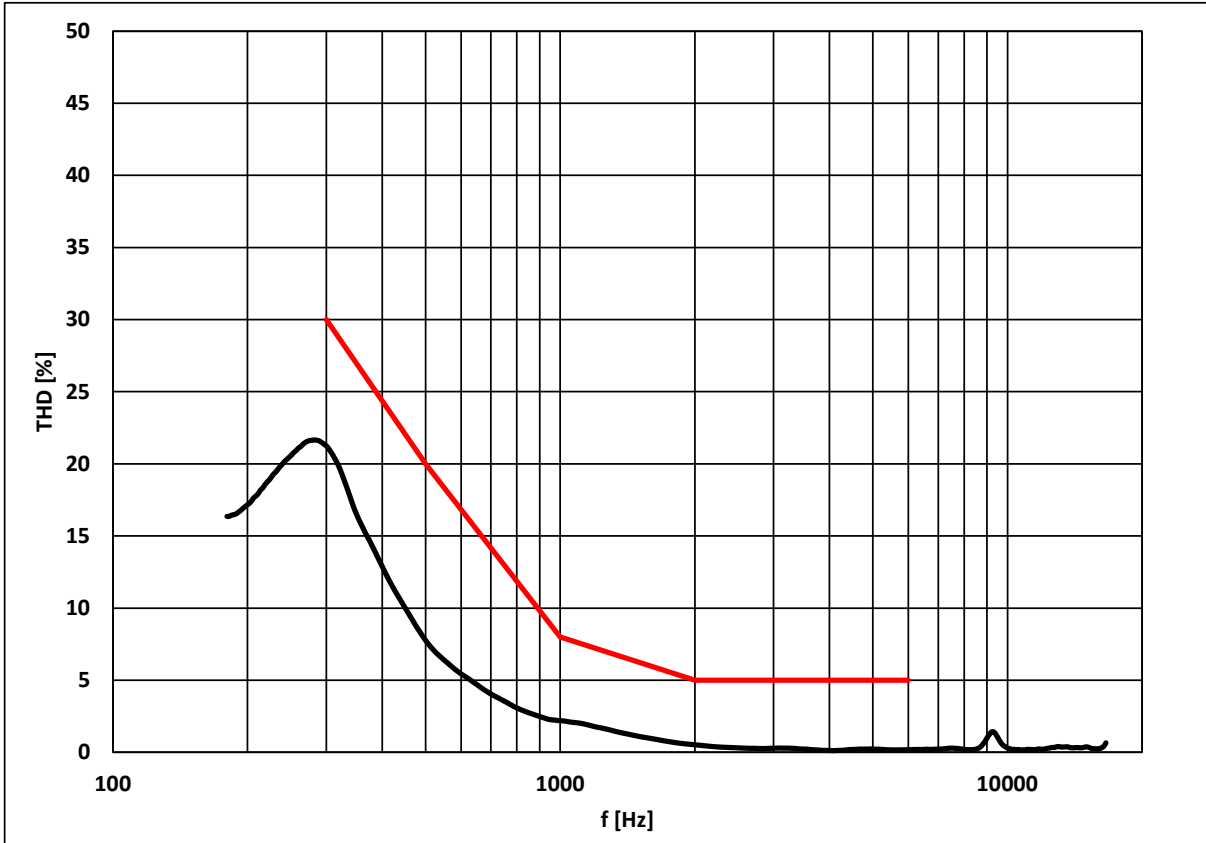

THD tolerance window	
f [Hz]	THD [%]
300	30
500	20
1000	8
2000	5
6000	5

2403 260 00086

3.3. Electro-Acoustic Parameters

Loudspeaker mounted in adapter acc. to 3.6 and 3.8. Test signal is a sinusoidal sweep.

1. Rated impedance	Z:	8Ω
2. Voice coil resistance	R:	6.8Ω±10%
3. Resonance frequency (in 1cm ³ back volume @ 500mW)	f ₀ :	850Hz±10%
4. Maximum usable excursion x _{max}	p-p:	0.6 mm _{p-p}
5. Nominal characteristic sensitivity (calculated for 1W in 1m) average from 2kHz to 5kHz		70.5±3dB
5.1. Measured characteristic sensitivity (at 500mW in 10cm) average from 2kHz to 5kHz		87.5±2dB
6. THD		according chapter 3.2.
7. Rub & buzz		no audible Rub & Buzz

All acoustic measurements at 23±2°C

3.4. Power Handling

Speaker mounted in lifetime test device (1cm³ back volume/open front)

Pink noise with high pass 12dB/Oct. at 850Hz, crest factor 2, used for all operating lifetime tests

1. Max short term power	1sec. ON, 1 min. OFF, 60 cycles	700mW (RMS)
Ambient temperature 70°C		
2. Max noise power (PHC continuous) 500h		500mW (RMS)
Ambient temperature 70°C		



3.5. Measurement Setup

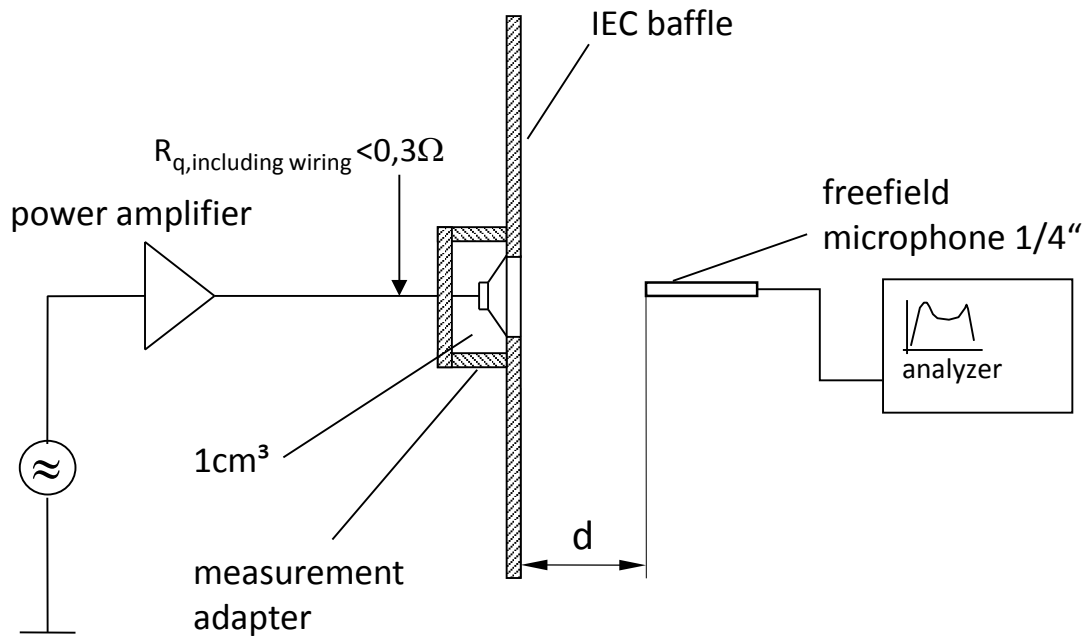

3.6. Measured Parameters

3.6.1. Sensitivity

SPL is expressed in dB rel 20μPa, computed according to IEC 268-5. Measurement set up and parameters according chapter 3.5. This test is performed for 100% of products in the production line.

3.6.2. Frequency response

Frequency response is measured according test set up in chapter 3.5. data sheet and checked against the tolerance window defined in chapter 3.1. This Test is performed for 100% of products in the production line.

3.6.3. Total harmonic distortion (THD)

Is measured according IEC 268-5 (2nd to 5th harmonics) and test set up in chapter 3.5. This test is performed for 100% of products in the production line.

3.6.4. Rub& Buzz

Rub & Buzz will be measured in the Inline-measuring device with a sinusoidal sweep. Rub & Buzz is defined as the maximum level of no harmonic energy, expressed as signal to non-harmonic content ratio, in a certain frequency-range. Signal and evaluation criteria are according to chapter 3.3. This test is performed for 100% of products in the production line.

2403 260 00086

3.7. Measurement adapter

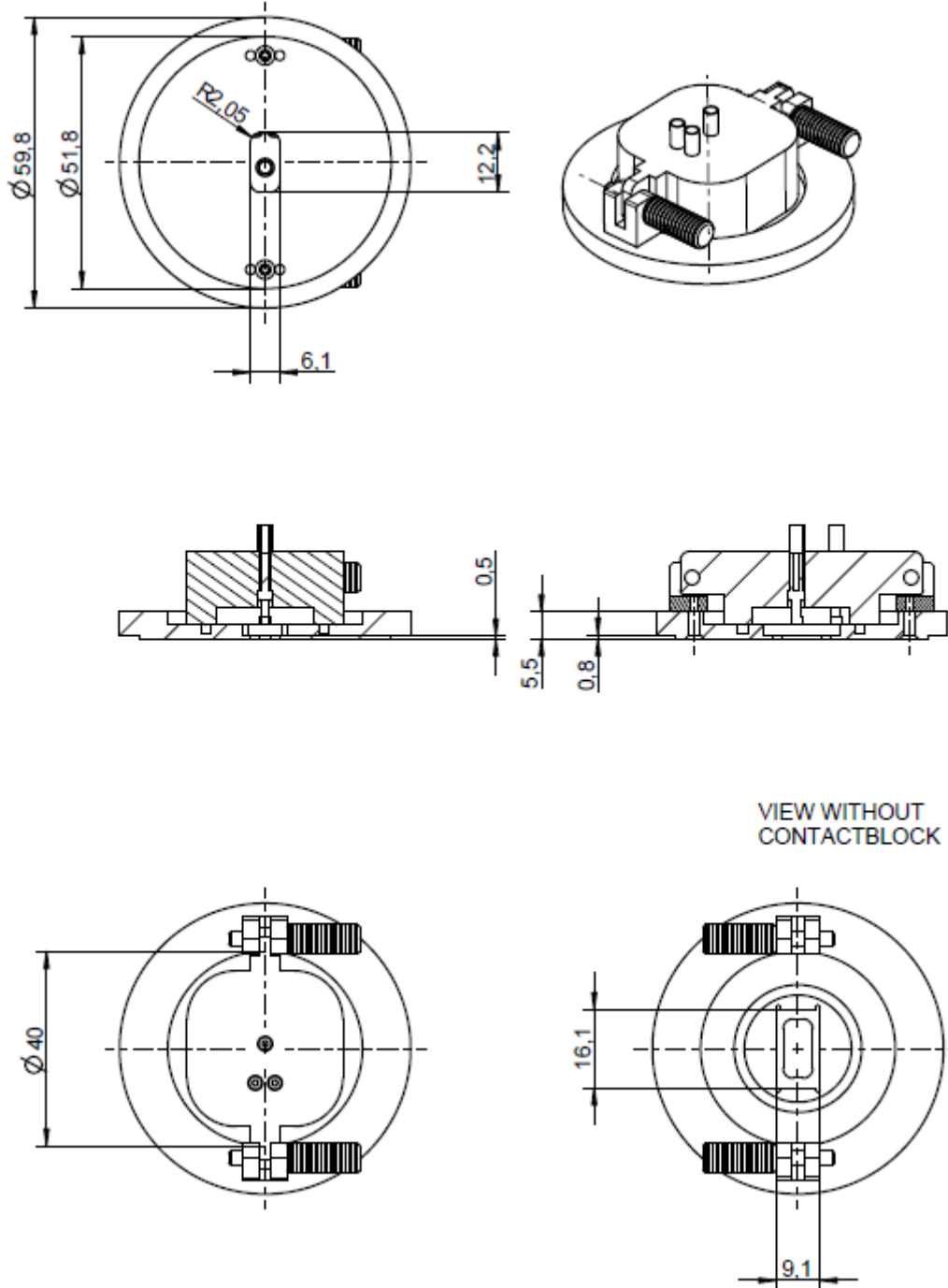

2403 260 00086

4. Environmental Conditions

4.1. Storage

The transducer fulfills the specified data after treatment according to the conditions of

ETS 300 019-2-1 Specification of environmental test: Storage
Test spec. T 1.2: Weather protected, not temperature controlled storage locations.

4.2. Transportation

The transducer fulfills the specified data after treatment according to the conditions of

ETS 300 019-2-2 Specification of environmental test: Transportation
Test Spec. T 2.3: Public Transportation

4.3. Functionality

The transducer fulfills the specified data after treatment according to the conditions of

ETS 300 019-2-5 Specification of environmental test: Ground vehicle installations
Test spec. T 5.1: Protected installation

ETS 300 019-2-7 Specification of environmental test: Portable and non-stationary use
Test spec. T 7.3E: Partly weather protected and non-weather protected locations.

5. Environmental tests

5.1. Qualification tests

According to our milestone plan (Product Creation Process), a complete qualification test will be done at design validation of products manufactured under serial conditions.

1x per year and product family a requalification takes place. The qualification process covers all tests described under 5.5 and a complete inspection.

5.2. Reliability tests

1x per month and product family samples are taken and submitted to tests described under 5.5.2

5.3. Sample Size, Sequence

Unless otherwise stated 20 arbitrary new samples will be used to perform each test for both, qualification and requalification test as described under 5.1 and 5.2.

5.4. Period of Shelf-Life

The period of shelf-life is 2 years.

5.5. Testing Procedures

5.5.1. Storage Tests

5.5.1.1. Cold Storage Test

Parameter	Test Method and Conditions	Duration	Evaluation Standard
Low Temperature Storage (Ref. EN 60068-2-1)	-40°C rel. humidity not controlled	168h	Measurements after 2 hours recovery time. All samples fully operable. All acoustical parameters according specification with tolerances increased by 50 %.

5.5.1.2. Heat Storage Test

Parameter	Test Method and Conditions	Duration	Evaluation Standard
Dry Heat Storage (Ref. EN 60068-2-2)	+85°C rel. humidity not controlled	168h	Measurements after 2 hours recovery time. All samples fully operable. All acoustical parameters according specification with tolerances increased by 50 %.

2403 260 00086

5.5.1.3. Temperature Cycle Test

Parameter	Test Method and Conditions	Duration	Evaluation Standard
Change of Temperature (Ref. EN 60068-2-14)	-40°C/+85°C Transition time <3 min. See Figure 5-1 below	5 cycles >2h for each temperature	Measurements after 2 hours recovery time. All samples fully operable. All acoustical parameters according specification with tolerances increased by 50 %.

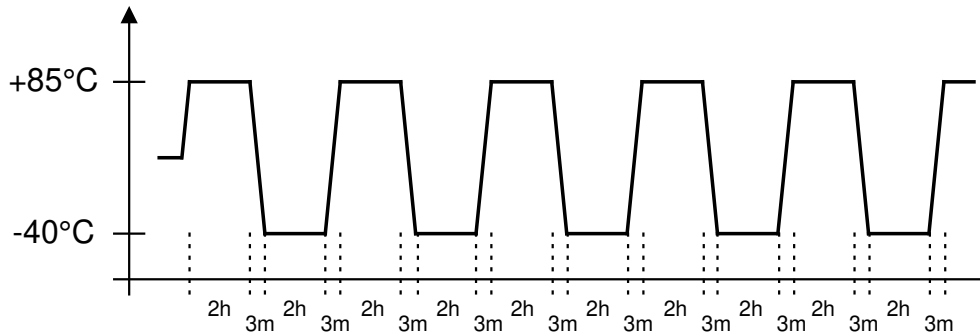

Figure 5-1: Temperature Cycle Test

5.5.1.4. Temperature / Humidity Cycle Test

Parameter	Test Method and Conditions	Duration	Evaluation Standard
Damp heat, cyclic (Ref. IEC 60068-2-30)	+25°C/+55°C 90% to 95% RH. Temp. change time <3h See Figure 5-2 below <u>Caution:</u> no condensed water on products!	6 cycles / 144h 12h at each temperature (inclusive temp ramp up/down)	Measurements after 2 hours recovery time. All samples fully operable. All acoustical parameters according specification with tolerances increased by 50 %.

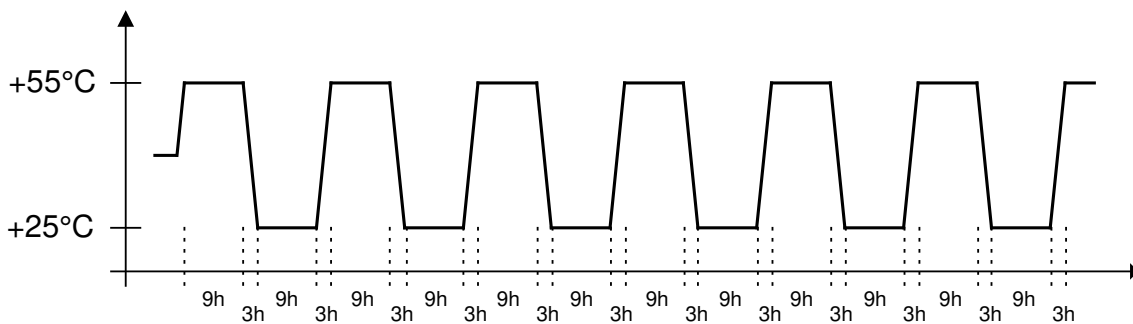

Figure 5-2: Temperature / Relative Humidity Cycle Test

5.5.2. Operating Tests

5.5.2.1. Cold Operation Test

Parameter	Test Method and Conditions	Duration	Evaluation Standard
Cold Operation Test (Ref. EN 60068-2-1)	-20°C rel. humidity not controlled signal acc. Chapter 3.4	72h	Measurements after 2 hours recovery time. All samples fully operable. THD may be increased after test. All other acoustical parameters according specification with tolerances increased by 50 %.

5.5.2.2. Dry Heat Operation Test

Parameter	Test Method and Conditions	Duration	Evaluation Standard
Dry Heat Operation (Ref. EN 60068-2-2)	+70°C rel. humidity not controlled signal acc. Chapter 3.4	500h	Measurements after 2 hours recovery time. All samples fully operable. The allowable change in sensitivity shall not be greater than 3 dB. All other acoustical parameters according specification with tolerances increased by 50 %.

5.5.3. Salt Mist Test

Parameter	Test Method and Conditions	Duration	Evaluation Standard
Salt Mist (Ref. IEC60068-2-52, Kb / Severity 2)	The part must be subjected to 2 hours spray of 5% NaCl salt mist, at 35°C then be left at 40°C and 95% RH for 22h.	3 cycles	The samples shall be washed after the test with distilled water and dried at T < 50°C. Component may have reduced performance, but must still function properly. The allowable sensitivity difference shall not be greater than ±3dB from initial sensitivity.

5.5.4. Guided Free Fall Test - protected product

Parameter	Test Method and Conditions	Conditions / Sample size	Evaluation Standard
Mechanical shock (Ref. IEC60068-2-32 Ed), Procedure 1	Speaker in drop test box or representative mechanics from a height of 1.5m onto concrete floor.	30 units Two drops on each side (2x6) One drop on each edge (1x12) Two drops on each corner (2x8) (40 drops in total)	Component may have reduced performance, but must still function properly. The allowable sensitivity difference shall not be greater than ± 3 dB from initial sensitivity.

5.5.5. Random Free Fall Test (Tumble Test) – protected product

Parameter	Test Method and Conditions	Conditions / Sample size	Evaluation Standard
Impact durability (in a Tumble Tester) (Ref. IEC60068-2-32 Ed) (SPR a7.1.1)	Speaker in drop test box or representative mechanics. Random drops on steel base.	30 units 180 drops, 1m DUT power off	Component may have reduced performance, but must still function properly. The allowable sensitivity difference shall not be greater than ± 3 dB from initial sensitivity.

5.5.6. Resistance to Electrostatic Discharge

Parameter	Test Method and Conditions	Conditions / Sample size	Evaluation Standard
Resistance to ESD IEC61000-4-2 Level 4 (SPR c 2.5.1)	One pole is grounded and the ESD pulse is applied to the other pole. The speaker must be stressed first with one polarisation and then with the other polarisation. DUT must be discharged between each ESD exposure. Level 4: contact +/- 8kV, air +/- 15kV	10 exposures on each polarity / 5 units DUT Power off	All samples fully operable. All acoustical parameters according specification with tolerances increased by 50%.

2403 260 00086

6. Related Documents

IEC 268-5	Sound System equipment Part 5: Loudspeaker
IEC 68-2	Environmental testing
EN 60068-2	Environmental testing
ISO 2859 - 1	Sampling procedures for inspection by attributes Part 1: Sampling plans indexed by acceptable quality level (AQL) for lot-by-lot inspection
ISO 3951	Sampling procedures and charts for inspection by variables for percent defectives.
ETS 300 019-2-1	Specification of environmental test: Storage Test spec. T 1.2: Weather protected, not temperature controlled storage locations
ETS 300 019-2-2	Specification of environmental test: Transportation Test spec. T 2.3: Public Transportation
ETS 300 019-2-5	Specification of environmental test: Ground vehicle installations Test spec. T 5.1: Protected installation
ETS 300 019-2-7	Specification of environmental test: Portable and non-stationary use Test spec. T 7.3E: Partly weather protected and non-weather protected locations

2403 260 00086

7. Change History

Status	Version	Date	ECR	Comment / Changes	Initials of owner
Obsolete	A	06.04.12	3657	First Release	ET/SZ/CP
Obsolete	B	25.06.12	3736	Update pulloff force	MS/CP
Obsolete	C	11.07.12	3768	New membrane material/change RDC to 6.8 Ω	SZ/CP
Release	D	20.08.12	3902	Update Rib-design pictures/final production release	MS/CP/CS/RB

8. Disclaimer

Stresses above the Absolute Maximum Ratings may cause permanent damage to the device. These are stress ratings only. The device may not function when operated at these or any other conditions beyond those indicated under “Electrical and Acoustical Specifications”. Exposure beyond those indicated under “Electrical and Acoustical Specifications” for extended periods may affect device reliability.

This product is not qualified for use in automotive applications

Frequency range for Telekom use

The information contained in this literature is based on our experience to date and is believed to be reliable and it is subject to change without notice. It is intended as a guide for use by persons having technical skill at their own discretion and risk. We do not guarantee favorable results or assume any liability in connection with its use. Dimensions contained herein are for reference purposes only. For specific dimensional requirements consult factory. This publication is not to be taken as a license to operate under, or recommendation to infringe any existing patents. This supersedes and voids all previous literature.

