

CSHV SERIES

005999
Issue 4

Open Loop Current Sensors

DESCRIPTION

The CSHV Series are open loop current sensors that use Hall-effect sensing and patented Honeywell technology to bring the best combination of performance and reliability for current sensing applications.

These products are non-intrusive and electrically isolated from the monitored circuit. This ensures a simple sensing method. They are rated for a primary current measurement range of ± 100 A to ± 1500 A dc.

The CSHV Series is AEC-Q100 qualified to meet higher quality and reliability. For motor control applications, the current measurement is directly proportional to the motor torque. Current measurement can also be used to determine the speed at which the motor is turning. Such speed information can be calculated by understanding how the control algorithm affects the current level.

CUSTOMIZATION

The CSHV Series may be customized to best meet specific application needs. Solutions may be tailored to exact specifications for improved time to market, lower total system costs, and enhanced reliability.

Honeywell provides global technical assistance and engineering/service support.

DIFFERENTIATION

- **Accuracy:** Hall-effect sensing and stable amplification circuitry for improved accuracy over the full operating temperature range.
- **Magnetic immunity:** Optimized magnetic circuit allows for excellent performance in diverse magnetic environments.
- **Flexible:** Customizable to meet specific application requirements.

VALUE TO CUSTOMERS

- **Accurate:** Designed to enable precise battery state measurement for improved user experience. Accurate current sensing enables precise and smooth motor control
- **Fast Response Time:** Fast response time allows fault detection and asset protection before catastrophic failure.
- **Ease of use:** Magnetic immunity allows for easy integration into different magnetic environments.
- **Easy system integration:** Analog voltage output may be used by battery management system.

FEATURES

- Active open loop current sensing using Hall-effect technology
- High accuracy and low temperature drift
- Operating temperature of -40°C to 125°C [-40°F to 257°F]
- Analog voltage output
- CE and UKCA certification; REACH and RoHS compliant
- AEC-Q100 qualified for higher reliability



APPLICATIONS

- Current measurement for battery management systems in electrified vehicles (EV, HEV, PHEV, BEV)
- Current leakage detection and fault isolation in battery charging systems
- Current measurement in energy storage systems
- Fault detection in heavy industrial equipment



PORTFOLIO

Honeywell offers a variety of current sensors for potential use in many applications. To view the entire product portfolio, [click here](#).

Honeywell

OPEN LOOP CURRENT SENSORS CSHV SERIES

TABLE 1. ABSOLUTE MAXIMUM RATINGS

CHARACTERISTIC	SYMBOL	UNIT	PARAMETER			CONDITION
			MIN.	TYP.	MAX.	
Supply voltage max.	$V_{S\max.}$	V	—	—	10	—
Reverse supply voltage max.	$V_{R\max.}$	V	-0.3	—	—	—
Output voltage max.	$V_{OUT\max.}$	V	-0.3	—	10	V_{OUT} reverse/forward voltage
Output current max.	$I_{OUT\max.}$	mA	-10	—	10	—
Ambient storage temperature	—	°C	-40	—	125	—
Electrostatic discharge voltage	V_{ESD}	kV	—	—	8	—
RMS voltage for AC isolation test	V_{DWW}	kV	—	—	2.5	50 Hz, 1 min
Creepage distance	d_{Cp}	mm	4.9	—	—	—
Clearance	d_{Cl}	mm	4.9	—	—	—
Comparative tracking index	CTI	—	PLC3	—	—	—

TABLE 2. OPERATING CHARACTERISTICS IN NOMINAL RANGE (I_{PN})

CHARACTERISTIC	SYMBOL	UNIT	PARAMETER			CONDITION
			MIN.	TYP.	MAX.	
Primary current, nominal DC	I_{PN}	A	$-I_{PN}$	—	I_{PN}	—
Supply voltage	V_S	V	4.5	5	5.5	—
Output voltage	V_{OUT}	V	$V_{OUT} = \frac{V_S}{5} (G * I_P + V_{OS})$			$I_P = (V_{OUT} * \frac{5}{V_S} - V_{OS}) / G$
Output voltage (at $I_P = 0$)	V_{OS}	V	—	2.500	—	—
Electrical offset voltage	$V_{OS,ELECT}$	mV	—	±3	—	$T_A = 25^\circ\text{C}, V_S = 5\text{ V}$
Magnetic offset voltage	$V_{OS,MAG}$	mV	—	±2	—	$T_A = 25^\circ\text{C}, V_S = 5\text{ V}$
Current consumption	I_{SUPPLY}	mA	— —	13 —	— 16	$T_A = 25^\circ\text{C}, V_S = 5\text{ V}$ —
Load resistance	R_L	Ohm	10k	—	—	—
Output impedance	R_{out}	Ohm	— —	1 —	— 10	$T_A = 25^\circ\text{C}$ $T = -40^\circ\text{C to } 125^\circ\text{C}$
Ratiometric error	ϵ_r	%	—	±0.5	—	—
Sensitivity	G	mV/A	—	$2000/I_{PN}$	—	$T_A = 25^\circ\text{C}$
Sensitivity error: ±100 A to ±1200 A ±1500 A	ϵ_g	%	— —	±0.6 ±0.8	— —	$T_A = 25^\circ\text{C}, V_S = 5\text{ V}$ $T_A = 25^\circ\text{C}, V_S = 5\text{ V}$
Linearity error	ϵ_L	%	-1	—	1	% of full scale output
Ambient operating temperature	—	°C	-40	—	125	—
Average temperature coefficient	$V_{OS,ELECT}$	mV/°C	—	±0.04	—	—
Average temperature coefficient of G	—	%/°C	—	±0.02	—	—
Step response time (10 % to 90 %)	t_r	µs	—	2	6	—
Frequency bandwidth	BW	kHz	45	—	—	-3 dB
Output RMS noise (RMS)	—	mV	—	—	2	—

¹ See Table 4 for catalog listing specifics.

OPEN LOOP CURRENT SENSORS CSHV SERIES

TABLE 3. MECHANICAL CHARACTERISTICS

CHARACTERISTIC	DESCRIPTION
Housing material	PBT + GF30 %
Mounting screw	M4, 2,5 N m torque max.
Mating electrical connector	TE MPN 1473672-1
Weight	58 g

TABLE 4. ORDER GUIDE

CATALOG LISTING	MEASURE RANGE (A)	SENSITIVITY (mV/A at $V_s = 5\text{ V}$)	OFFSET (mV at $V_s = 5\text{ V}$)		ACCURACY (% at $V_s = 5\text{ V}$)	
			25°C	-40°C to 85°C	25°C	-40°C to 85°C
CSHV100A-001	±100	20	±7 mV	±25 mV	±1 %	±2 %
CSHV200A-001	±200	10	±7 mV	±15 mV	±1 %	±2 %
			25°C	-40°C to 125°C	25°C	-40°C to 125°C
CSHV300A-001	±300	6.667	±7 mV	±18 mV	±1 %	±2 %
CSHV400A-001	±400	5	±7 mV	±13 mV	±1 %	±2 %
CSHV500A-001	±500	4	±7 mV	±10 mV	±1 %	±2 %
CSHV600A-001	±600	3.333	±7 mV	±10 mV	±1 %	±2 %
CSHV700A-001	±700	2.857	±7 mV	±10 mV	±1 %	±2 %
CSHV800A-001	±800	2.5	±7 mV	±10 mV	±1 %	±2 %
CSHV900A-001	±900	2.222	±7 mV	±10 mV	±1 %	±2 %
CSHV1000A-001	±1000	2	±7 mV	±10 mV	±1 %	±2 %
CSHV1100A-001	±1100	1.818	±7 mV	±10 mV	±1 %	±2 %
CSHV1200A-001	±1200	1.667	±7 mV	±10 mV	±1 %	±2 %
CSHV1500A-001	±1500	1.333	±7 mV	±10 mV	±2 %	±3 %

Figure 1. Nomenclature

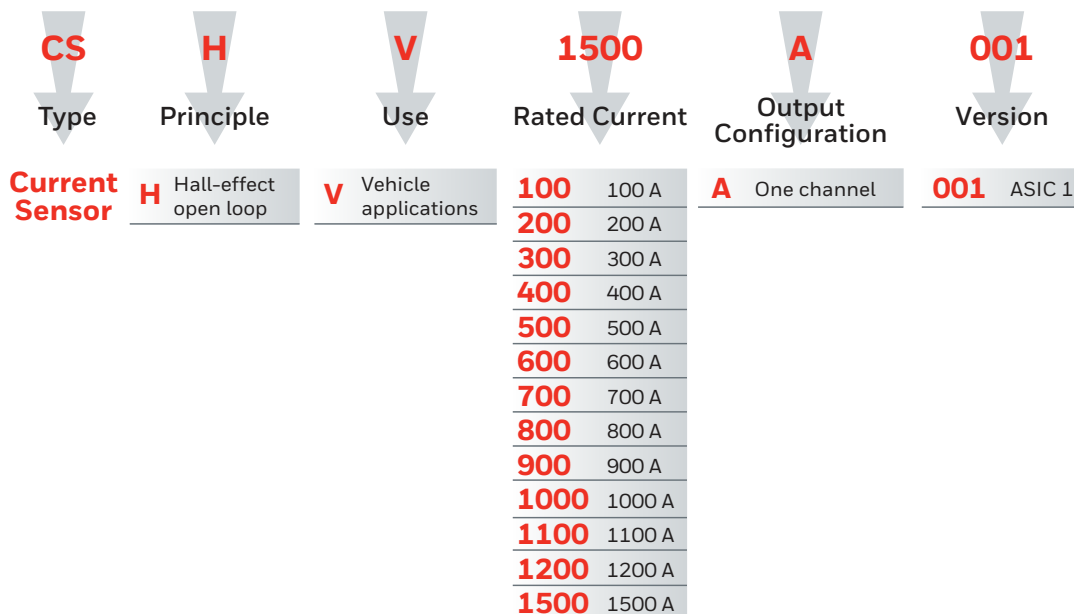

OPEN LOOP CURRENT SENSORS CSHV SERIES

Figure 2. Dimensional Drawings (For reference only: mm/in)

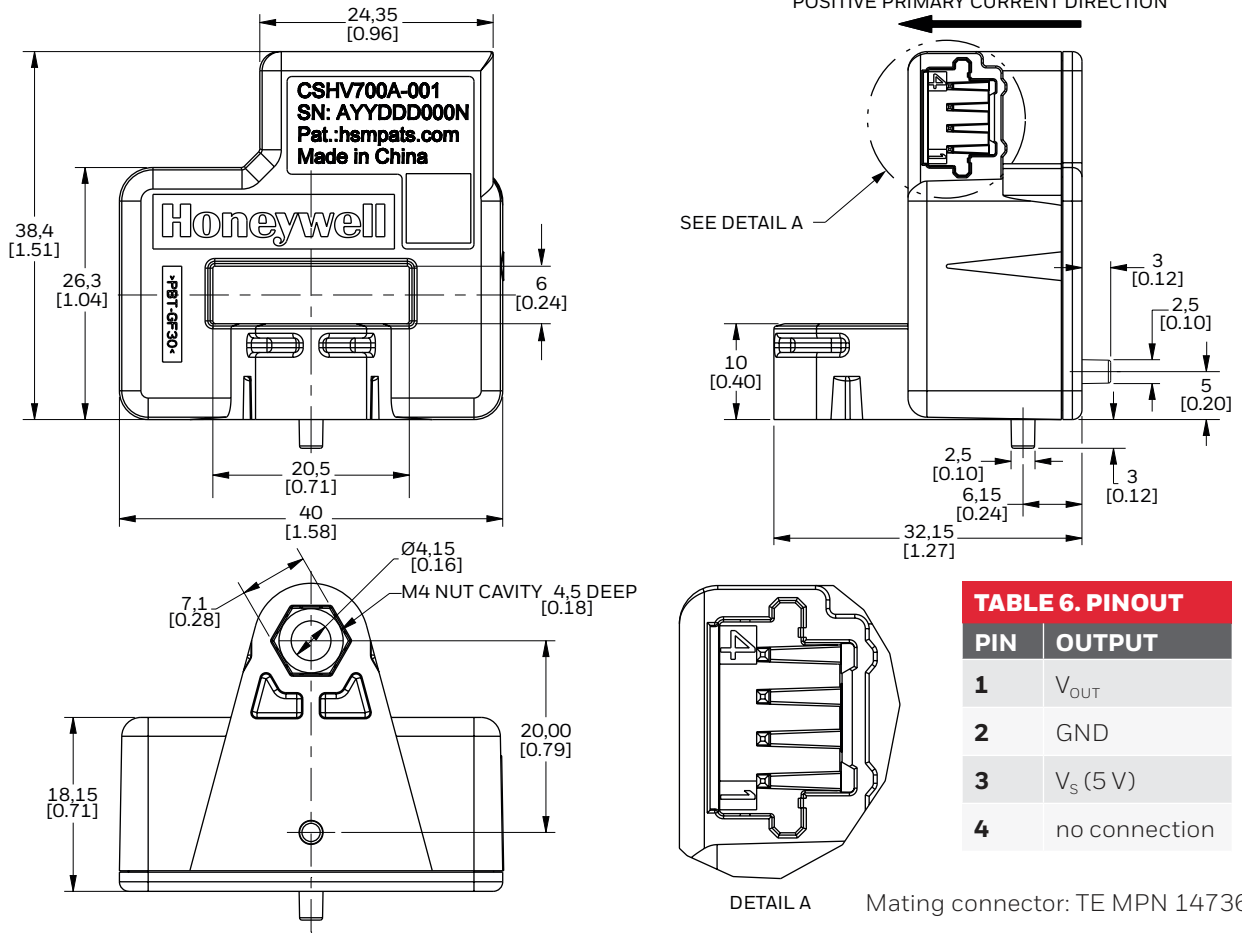

Figure 3. Part Marking Details

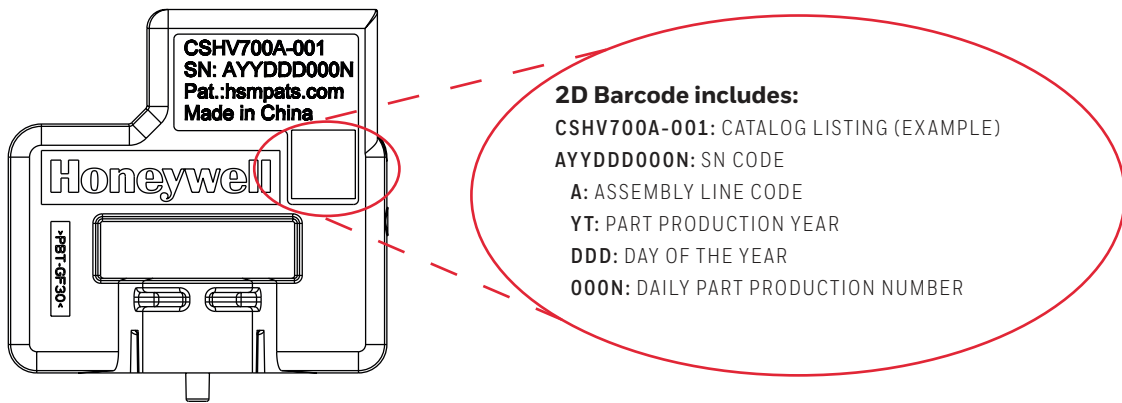
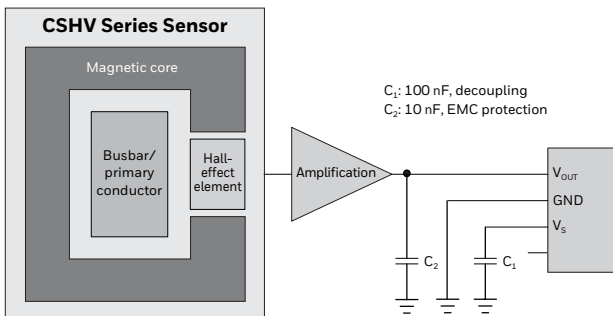

Figure 4. Electrical Diagram



NOTICE

SENSOR ACCESSIBILITY

- Ensure that the current sensor is installed in a suitable electrical enclosure which is only accessible with the use of special tools.

WARRANTY/REMEDY

Honeywell warrants goods of its manufacture as being free of defective materials and faulty workmanship during the applicable warranty period. Honeywell's standard product warranty applies unless agreed to otherwise by Honeywell in writing; please refer to your order acknowledgment or consult your local sales office for specific warranty details. If warranted goods are returned to Honeywell during the period of coverage, Honeywell will repair or replace, at its option, without charge those items that Honeywell, in its sole discretion, finds defective.

The foregoing is buyer's sole remedy and is in lieu of all other warranties, expressed or implied, including those of merchantability and fitness for a particular purpose. In no event shall Honeywell be liable for consequential, special, or indirect damages.

While Honeywell may provide application assistance personally, through our literature and the Honeywell web site, it is buyer's sole responsibility to determine the suitability of the product in the application.

Specifications may change without notice. The information we supply is believed to be accurate and reliable as of this writing. However, Honeywell assumes no responsibility for its use.

FOR MORE INFORMATION

Honeywell Sensing and Safety Technologies services its customers through a worldwide network of sales offices and distributors. For application assistance, current specifications, pricing or the nearest Authorized Distributor, visit [our website](#) or call:

USA/Canada	+1 302 613 4491
Latin America	+1 305 805 8188
Europe	+44 1344 238258
Japan	+81 (0) 3-6730-7152
Singapore	+65 6355 2828
Greater China	+86 4006396841

Honeywell Sensing and Safety Technologies

830 East Arapaho Road
Richardson, TX 75081
sps.honeywell.com/ast

WARNING PERSONAL INJURY

DO NOT USE these products as safety or emergency stop devices or in any other application where failure of the product could result in personal injury.

Failure to comply with these instructions could result in death or serious injury.

WARNING MISUSE OF DOCUMENTATION

- The information presented in this product sheet is for reference only. Do not use this document as a product installation guide.
- Complete installation, operation, and maintenance information is provided in the instructions supplied with each product.

Failure to comply with these instructions could result in death or serious injury.